HP PaintJet XL300 Color Printer



User's Guide

User's Guide



HP PaintJet XL300

Regarding this document...

Our world is rapidly growing smaller as the needs for global communications become increasingly larger. We at Hewlett-Packard want to provide you with documentation that can be understood globally as well as locally. Our goal is to accommodate a wide audience. A language shared by more than one culture (for example, English or Spanish) challenges this goal by using different words in different locations. While you personally may have chosen a different word or phrase, it is our intent to use terms and expressions in this document that are clear and understandable to anyone who uses the language. This is our sincere and best effort at creating documentation that is *globally* understood and accepted.

Contents

1 Your printer's features

- Your printer's features 1-3
- Adding more memory to your printer 1-4
- JetDirect peripheral interface cards 1-5
- Autosensing for AppleTalk/RS-422 and Centronics I/O 1-6
- Controlling your printer 1-7
- Using a shared printer 1-8

2 Using media and print cartridges

- What you need to know about media 2-3
- Media versatility 2-6
- Load a sheet of paper or transparency film (manual loading) 2-9
- What you need to know about print cartridges 2-11

3 Using your printer

- Using the control panel 3-3
- Using the rear-panel switches 3-15

4 Using software

- Before you start 4-3
- Understanding drivers and resources 4-4
- Printing a file 4-7
- Setting margins with software 4-8
- Printing on transparency film or glossy paper 4-9
- Writing your own graphics program 4-10



5 Using typefaces

- Default typefaces 5-3
- Font rotation 5-4
- Disk-based typefaces (PCL 5 only) 5-5
- Downloading bitmapped-fonts and scalable typefaces 5-6
- Deleting disk-based typefaces from printer memory 5-8
- Disk-based typeface hints 5-9
- Using typeface cartridges 5-10
- Typeface cartridge defaults 5-11
- PostScript typefaces 5-12

6 Using color

- Why use color? 6-3
- Color and your software 6-4
- Matching screen colors and print colors 6-5
- Importing color graphics 6-6
- Color best practices 6-7
- Presentations 6-9

7 Troubleshooting

- Maintaining your printer 7-3
- Print cartridge problems 7-4
- Media problems 7-12
- Printer operation problems 7-14
- Print quality problems 7-19
- Network problems 7-20
- Software application problems (Macintosh) 7-21
- Returning your printer for service 7-22
- Getting help 7-23



8 Installing printer options

Installing the memory card 8-3

Installing a typeface cartridge 8-7

Technical information

Regulatory notices T-2

Declaration of conformity T-4

Power cord options T-12

To obtain a Material Safety Data Sheet (MSDS) T-14

Centronics cable schematics T-15

HP PaintJet XL300 command set T-18

Ordering information

How to order HP PaintJet XL300 accessories O-2

Additional documentation O-8

Using HP FIRST O-9

Glossary G-1**Index I-1**

Your printer's features

Chapter information

This chapter includes information about the following subjects:

- Adding memory to your printer
- Using optional interface cards
- Switching input languages
- Controlling your printer
- Using a shared printer

If you have not yet unpacked or set up the printer, refer to the HP PaintJet XL300 *Getting Started* guide.



Your printer's features

The HP PaintJet XL300 printer produces high quality, 300 dpi, color output on a variety of media types. Other features include:

- LaserJet IIISi compatibility, including PCL 5, typefaces, memory, and optional direct network interface.
- Multi-platform printing; I/O switching between Centronics, AppleTalk or RS422, and optional direct network interface.
- True Adobe PostScript® Level 2 as an accessory upgrade or as a fully configured product.
- PC or Macintosh® networking capability for easily shared, cost effective color.
- Convenient unattended printing.
- HP-GL/2 technical and palette extensions allow use of HP-GL/2 drivers for CAD applications.
- Environment drivers for Microsoft Windows and Macintosh provide Truetype™ and ATM® support, color matching to the screen, and Pantone® color matching (when using an application that is Pantone certified with a Pantone color).
- Full B-size/Tabloid capability (B, A3, B4).

The printer connects quickly and easily to your PC or Macintosh computer, and provides you with high-quality text and graphics printing. You can produce full page color charts and graphs for your reports and create complete transparency presentations in vivid color.



Adding more memory to your printer

Your HP PaintJet XL300 printer contains 2 megabytes of resident memory (4 megabytes in the PostScript version). You can install additional memory in the printer using the memory expansion board (full capacity of the printer is 18 megabytes). Printer memory can be expanded in blocks of 1, 4, or 8 megabytes (refer to the “Ordering Information” chapter in this manual).

Adding more memory lets you:

- Print larger files.
- Create more complex graphics.
- Free up your computer to do other jobs.
- Print a full B/A3-size page of graphics.
- Download more disk-based typefaces.

Refer to chapter 8, “Installing printer options” in this manual, if you wish to add more memory to your printer.

The resident memory is enough to print a full A- or A4-size sheet of 300 dpi, color graphics from most applications. More complex applications, such as COREL *DRAW!*® and Micrografx®, may require additional memory.

If your file is too large or complex to print, the printer will print only the amount of the file within the resident memory. The printer will also print “Not Enough Printer Memory — See User’s Guide” at the bottom of the page.



JetDirect peripheral interface cards

The HP PaintJet XL300 Color Printer supports the following HP JetDirect peripheral interface cards:

- Novell NetWare (Ethernet or Token Ring)
- LAN Manager
- TCP-IP
- EtherTalk
- HP-IB

The HP PaintJet XL300 printer can use many of the same network cards and interface options as the HP LaserJet IIISi. Contact your HP Sales and Support office for the latest information on available options.



Autosensing for AppleTalk/RS-422 and Centronics I/O

I/O autosensing allows you to connect computers with different interfaces to your printer simultaneously. The printer recognizes which interface the data is coming from and processes it properly. For example, you can have the printer connected to both a Macintosh computer and a PC. If the person on the Macintosh computer prints a file and the person on the PC prints a file, your printer completes the one it received first, then switches to the other interface to process the other file.

Autosensing will also recognize when you have any HP JetDirect peripheral interface card installed in the printer and will automatically switch to that I/O port if the file on that port is received.

If a person printing on one interface cancels a print job (or it is otherwise “abnormally terminated” such as by a power failure), the printer will wait 5 minutes before accepting data from another interface.



Controlling your printer

DOS only

The easiest way to control your printer is through a software application, such as a word processing package. If your software does not contain printer drivers that let you control the HP PaintJet XL300, you may be able to place printer commands directly in your file. Refer to the "Technical information" chapter of this manual for printer commands.

Your HP PaintJet XL300 printer allows you to use software, printer commands (escape sequences), or the control panel to determine how it prints. If you share the printer through a network or other system, your network administrator may place restrictions on your use of these methods.

Most software applications allow you to choose printing instructions from a menu or enter printing instructions (escape sequences) directly in your file. However, this method of controlling your printer requires you to learn printer commands. Printer commands for the HP PaintJet XL300 printer can be found in the "Technical information" chapter of this manual.

Remember, software settings always override control-panel settings.



Using a shared printer

The HP PaintJet XL300 printer can be used in a shared environment with PCs using a Local Area Network (LAN) or switchbox and with Macintoshes using AppleTalk. When you use your printer in a shared environment, be aware of these considerations:

- Any rear-panel or control-panel changes may affect everyone else's print jobs. Check with your network administrator before making any rear-panel or control-panel changes.
- Coordinate the use of default fonts and downloaded disk-based typefaces with other users. This will save printer memory and help avoid unexpected printer output.
- Be aware that switching the system language affects other printer users and that if you switch between PCL 5 and PostScript operation, your printer will erase all downloaded disk-based typefaces and macros.

Your network operating system may automatically protect each user's print jobs from the effects of other users in the system. Check with your network printer administrator.



Using media and print cartridges

Using media and print cartridges

This chapter provides information to help you understand how different types of media affect printer performance and print quality. It provides helpful hints on how to get the best results from your printer using HP recommended media and print cartridges. Topics include:

- What you need to know about media
- Media versatility
- Hints for printing on glossy paper and transparencies
- Loading a sheet of media
- What you need to know about print cartridges



What you need to know about media

The HP PaintJet XL300 has been designed to print on plain paper such as photocopier or letterhead. CX JetSeries special paper can be used to maximize ink brilliance. LX JetSeries transparencies and glossy paper provide the highest print quality for finished presentations. Refer to the “Ordering information” chapter of this manual for media sizes and part numbers.

You can load paper or transparency film manually from the tray cover, up to 11.7 by 17.72 in. (297 mm by 450 mm). You can also load either paper or transparency film for automatic sheet feed in the media tray for unattended printing.

CAUTION

Do not try to print on envelopes or labels. They are likely to become jammed and could damage the printer.



Selecting paper

As you select paper for your HP PaintJet XL300 printer, be sure to choose only paper in the 16 to 24 lb (60 to 90 g/m²) range. Colored photocopy, bond, and letterhead paper, or preprinted forms that fall within this range may be used in the printer. Be sure that all paper is free of tears, dust, wrinkles, and curled or bent edges.

Plain paper has a print side. For the best print quality print only on the print side of the plain paper. The print side is not visible to the naked eye, so before you remove the paper from a ream to use in your printer, check the label on the end of the ream. The print side will be indicated by an arrow or other symbol on the label. Remove, undisturbed from the ream, the number of sheets of paper you wish to use in your printer, and load them print-side-down into the media tray.

CX JetSeries CutSheet paper has an arrow in the upper right-hand corner of the non-print side of the paper. Place the arrow side up in the media tray.

Handle all media types by the edges only. (The oil from fingerprints interferes with the ink.)

Avoid the following types of media:

- Paper greater than 24 lb (90 g/m²) or less than 16 lb (60 g/m²).
- Inkjet paper other than the recommended type.
- Paper with cutouts or perforations.
- Transparency film other than the recommended type.
- Multiple part forms.
- Paper sizes in the media tray other than the paper sizes listed in the “Technical information” chapter of this manual.



The maximum printable area for your HP PaintJet XL300 printer is shown below. Most software application packages allow you to specify where print will occur on the page by setting margins or column widths. As you set margins or columns through your software package, be sure to keep them within the printer's printable area. Refer to the "Technical information" chapter for other media information.

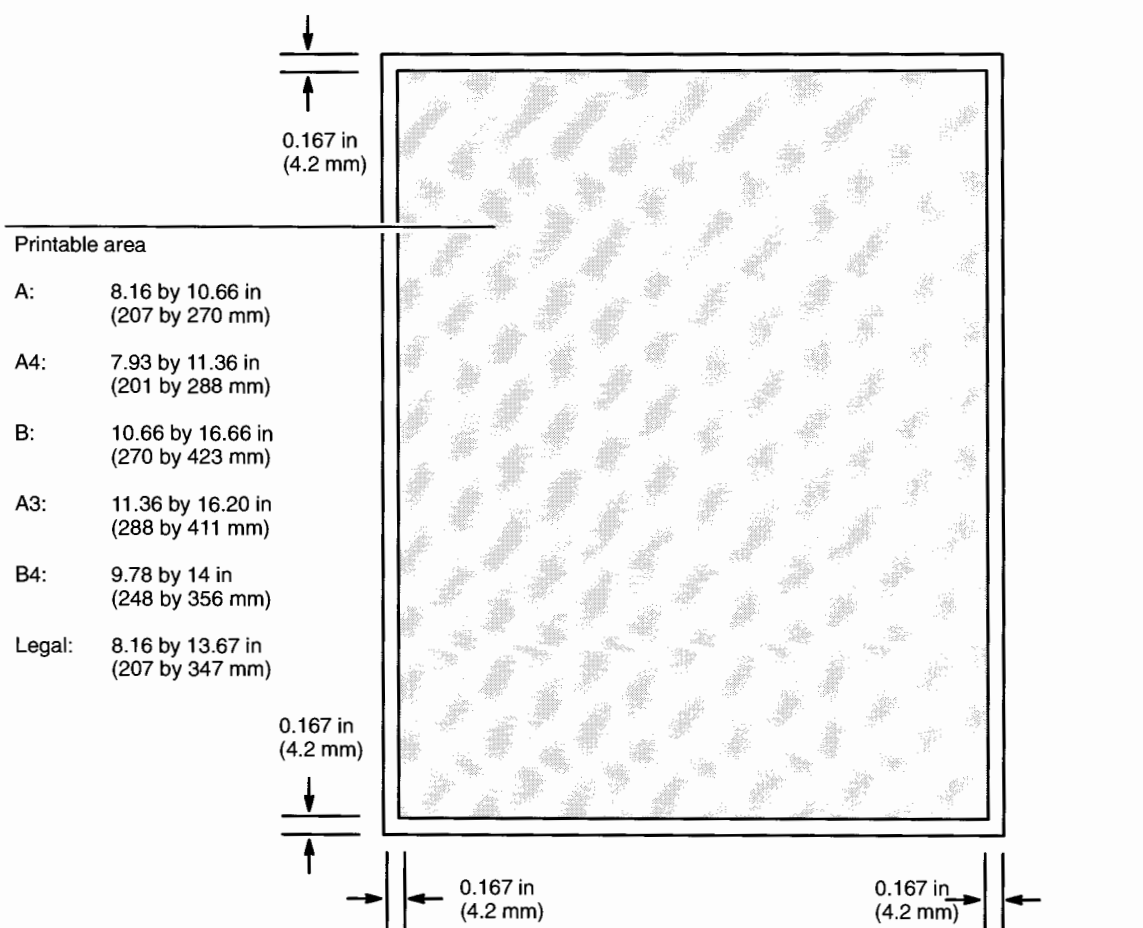

Media versatility

An exciting feature of the HP PaintJet XL300 is its printing versatility; the ability to print on a wide variety of media depending on your needs.

Given the wide variety of choices, the key to achieving optimal results is to select the right media based on your needs. The paper and film listed on the following page are specially designed to give you vivid colors for maximum impact and superior print quality.



| | Plain copier and Bond papers | HP CX JetSeries CutSheet Paper | HP LX JetSeries Glossy paper | HP LX JetSeries Transparency Film |
|--|---------------------------------|-----------------------------------|---------------------------------|--------------------------------------|
| Key: ★ = Good ★★ = Better ★★★ = Best | | | | |
| N/A = Not Applicable | | | | |
| Cost per sheet | ★★★ | ★★ | ★ | ★ |
| Brilliant colors | ★ | ★★ | ★★★ | ★★★ |
| Sharp, crisp edges | ★★ | ★★★ | ★★★ | ★★★ |
| Photo-like, glossy appearance | N/A | N/A | ★★★ | N/A |
| Smudge/water resistance | See Note | ★★★ | See Note | See Note |
| Fade resistant when exposed to light | ★★★ | ★★★ | ★★ | ★★★ |

NOTE: For a water-resistant, smear-resistant solution, use HP CX JetSeries Cut-sheet Paper.



Hints for printing on glossy paper and transparencies

Always select Glossy/Transparency media mode before printing on glossy paper or transparency film. Selecting Glossy/Transparency mode tells the printer to make multiple printing passes that will produce the intensity of ink needed for vibrant images. You may wish to experiment first with area fills to produce optimum results (ink bleeding may occur with area fills that are too dense). If available, select the media type using your software. Otherwise, use the control-panel **Media** button. Selecting the proper media type lets the printer create the best quality output.

To set the Glossy/Transparency mode press and release the **Media** button until the media light turns orange, the printer is set for glossy paper or transparency film.

You can load glossy paper or transparency film either manually from the tray cover or automatically from the media tray.

A *maximum* of 100 transparencies can be loaded into the media tray, printed, and stacked at a time.

Remember, software settings will override the control-panel **Media** button.



Load a sheet of paper or transparency film (manual loading)

- 1 Set the rear-panel English/Metric switch for the media size you are using.
English (down position) for A-size media — Metric (up position) for A4-size media.

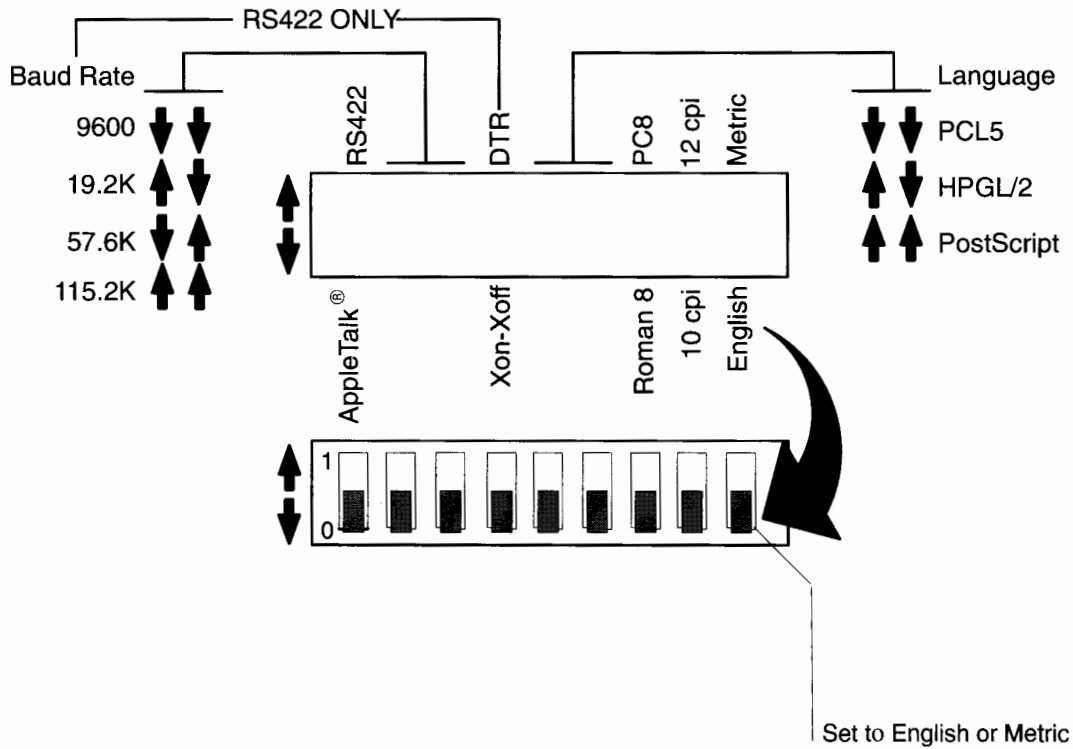

Using media and print cartridges

Loading a sheet of media

- 2 Place a sheet on the tray cover, aligning the long side against the appropriate rail on the right side of the tray cover. Load media with the side you want to print on facing down.
 - **Plain Paper** — Usually has print side marked on end of wrapping. Place print side down.
 - **CX JetSeries CutSheet Paper** — Place arrow (uncoated) side up.
 - **LX JetSeries Glossy Paper** — Place non-glossy side up.
 - **LX JetSeries Transparency Film** — Place the side with the paper strip so the paper strip enters the printer first.
- 3 Push the sheet into the printer.

The printer senses and automatically loads the sheet (the Manual light will flash).

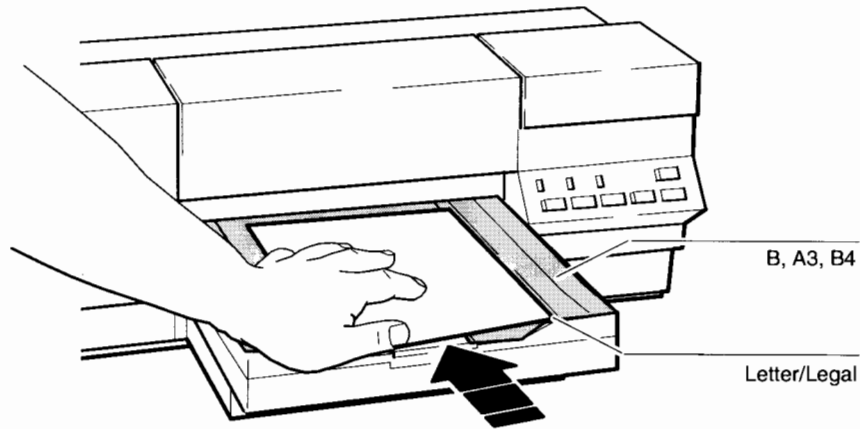

What you need to know about print cartridges

Your printer operates with four print cartridges: black, yellow, magenta, and cyan. It has 300 dpi graphics capability with a throughput of:

- 3–4 minutes per page (mpp) for A/A4-size special paper graphics.
- 1.5–6 mpp for A/A4-size plain paper graphics.
- 6–8 mpp for B/A3-size paper graphics.
- 5 mpp for A/A4-size glossy paper and transparencies.
- 1–2 pages of text per minute for A-size page (fast mode).



When printing *text only* (about 5% coverage) on A/A4-size media, ink lasts about 500 pages.

When printing *graphics* on A/A4-size media, using equivalent amounts of each color, ink lasts approximately:

- 320 pages at 15% density
- 50 pages at 100% density (screen dumps, bit-mapped graphics)

If you use one color more than others, you will need to change that print cartridge more often.



 Using your printer 

Using your printer

Use this chapter to become more familiar with the controlling features of your printer. It provides information about all the buttons, lights, and switches that you will use to set up your printer. This information includes:

- Using the control panel
- Using the rear-panel switches
- Selecting media sizes
- Selecting baud rate and handshake
- Selecting a printer language
- Establishing a default symbol set



Using the control panel

This section tells you how to use the features on the printer's control panel. Table and footnotes continue on the following page.

| | Use Button To... | The Light Tells You... |
|------------------|--|--|
| Ready | Initialize and reset the printer. | After initialization, the printer is ready to print. |
| On Line | Allow printer to communicate with the computer. ¹ | The printer is ready to communicate with the computer. |
| Form Feed | Advance the media through the printer. | |
| Reverse | Clear jammed media. (Media tray must be removed to use button). | |
| Media | Set the printer for the type of media being used. Start any of 5 demo printouts. ² | The currently-selected media type. |
| Test | Start the printer's self test. ³ Start the typeface list. ⁴ | |
| Busy | | Solid—the printer is waiting for data. Flashing—the printer is performing a function. |



Using your printer
Control-panel features

| | Use Button To... | The Light Tells You... |
|-------------------------------|------------------|---|
| Manual | | The printer is in manual feed mode. |
| Paper/Print Cartridges | | <ul style="list-style-type: none">• The printer is out of paper, or• The printer has a paper jam, or• The media tray is removed from the printer, or• At least one print cartridge isn't installed or has a bad printer connection, or• At least one print cartridge has failed during print nozzle ink-flow testing. |

- ¹ In most cases, the printer will come back on-line automatically (you won't need to push the **On Line** button) after you've corrected a problem. Two occasions when you *will* need to press the **On Line** button are 1) If a paper jam occurs and 2) If the paper tray is removed while the printer is trying to load paper.
- ² Refer to the 'Media button' section of this chapter.
- ³ Press and release immediately.
- ⁴ Press and hold down for 2 seconds.



Ready button

WARNING

Electric Shock Hazard. Even when the Ready light is OFF, power is still present within the printer if the power cord is connected to the outlet.

The **Ready** button is the white button with the “**U**” symbol on it. When pressed, the **Ready** button will either perform the initialization process that enables the printer to print (Ready light is on), or disable printing (Ready light is off). When the Ready light is on, you can press the **Ready** button twice to clear the printer’s memory and restart it.

During initialization, the printer clears left-over media in the print area, and checks its print limits and print cartridge alignment. Initialization takes approximately 5 minutes from a cold start (when the printer has not been in the Ready state for a while). If the printer has been running recently, initialization takes only 2 to 3 minutes.

After initializing, the printer’s Ready light and On Line light will remain lit.

Ready light

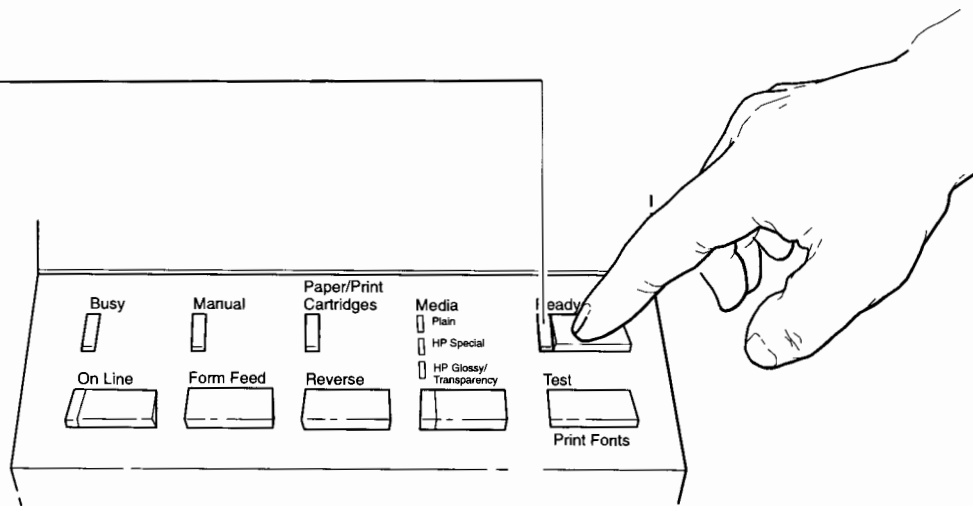

On Line button

The **On Line** button allows the computer to communicate with the printer. The On Line light is on steadily when the printer is ready to receive data from your computer; it flashes while data is being received.

In most cases after you have corrected a problem, the printer will come back on-line automatically and you won't need to press the **On Line** button. Two situations when you *will* need to press the **On Line** button are:

- If a paper jam occurs, and
- If the paper tray is removed while the printer is trying to load paper.

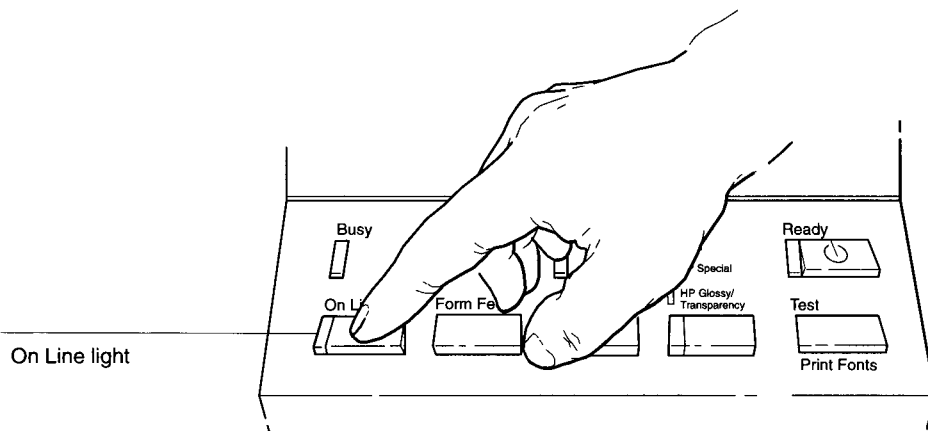



Form Feed button

The printer must be off line to use the **Form Feed** button. If the printer is on line (On Line light is on), push the **On Line** button and the On Line light will go off.

Press the **Form Feed** button:

- to continue printing, after loading paper into the paper tray.
- to cancel a file that's printing. (The printer will print the remainder of data in the printer buffer, however, and the whole file may be in the buffer.)
- to eject paper that is loaded in the printer.
- after going back on line, to continue printing after clearing a paper jam and replacing the paper tray.

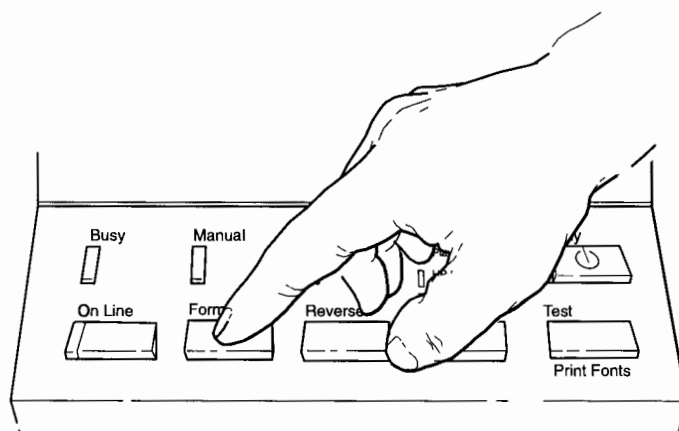

Reverse button

Use the **Reverse** button to clear jammed media in the printer. Refer to chapter 7, “Troubleshooting”, for information concerning jammed media.

Important You must remove the media tray from the printer to use the button.

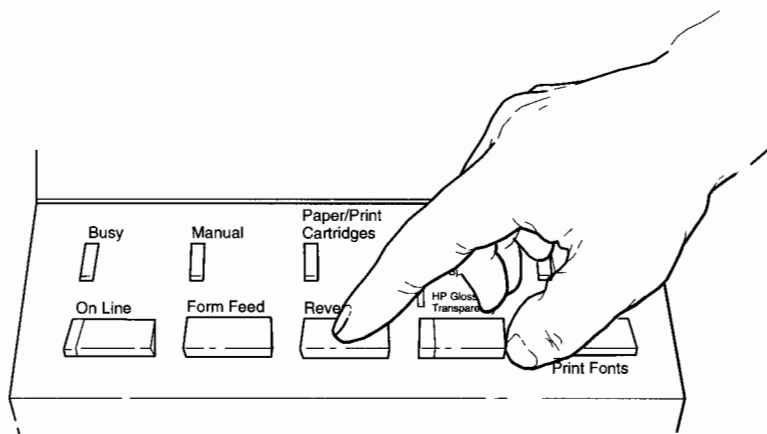

Media button and light

The **Media** button allows you to set the printer for the type of media on which you wish to print and, when used with the **On Line** button, will start the Demo printout. The Media light indicates which print media is selected. You can adversely affect the print quality of your job by not selecting the proper mode.

- When the Media light is off, the printer is set for plain paper.
- When the Media light is green, the printer is set for special paper (CX JetSeries).
- When the Media light is amber, the printer is set for glossy paper or transparency film (LX JetSeries).
- Demo printout. Press and hold the **On Line** button. While holding the **On Line** button, press and release the **Media** button (once for demo #1, twice for demo #2, and so on, up to demo #5. Release the **On Line** button.

NOTE: If you're using the Microsoft® Windows driver that came with your printer, the media type selection in the driver overrides the media type selection on the printer's front panel.

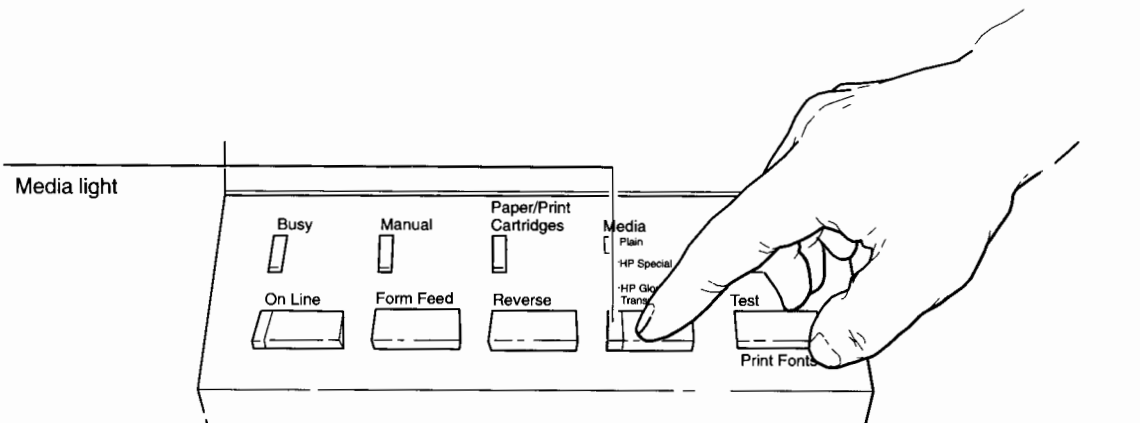

Test button

Use the **Test** button to perform one of the following functions:

- **Self test.** You can start the self test by pressing the **Test** button and releasing it immediately.
- **Font printout.** You can start the font printout by pressing the **Test** button for 2 seconds, then releasing it.

The font printout is several pages long.

Important

If you have the PostScript option, any downloaded PostScript fonts will be erased from the printer's memory when you perform the self test.

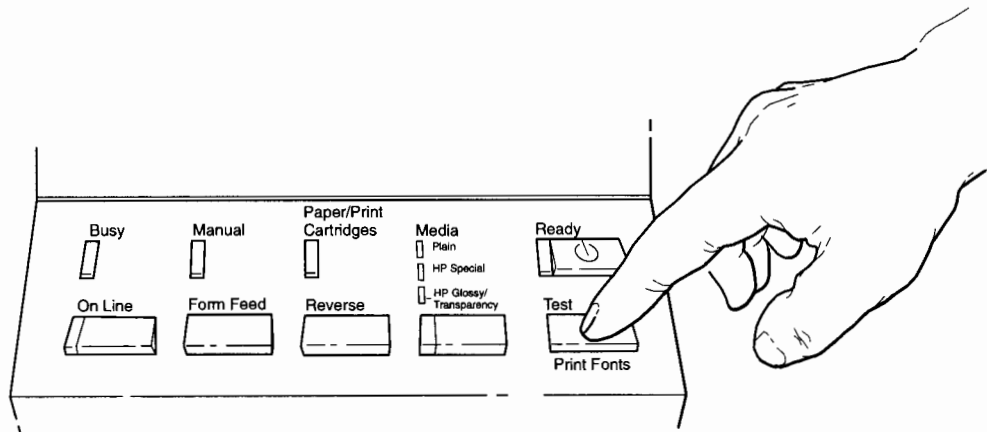

Busy light

The Busy light will glow steadily when the printer is waiting for more data to process, flash when the task is in progress and turn off when the printer has completed the task assigned to it.

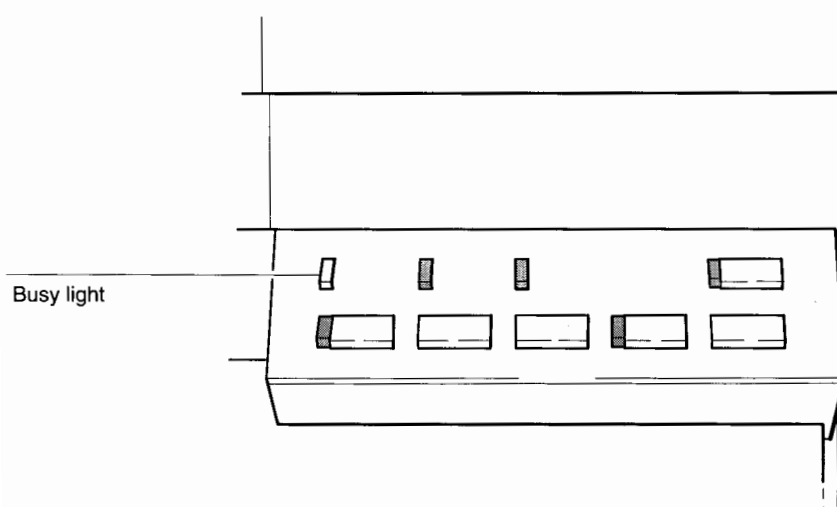

Manual light

The Manual light indicates that the printer is ready to manually feed media (when selected through your software application). However, you do not have to use your software application to manually feed media. It will also light whenever you feed media into the printer from the media tray cover by hand.

Use manual feed when printing multiple and/or consecutive pages that you want to load by hand—for example, if you are printing on company letterhead.

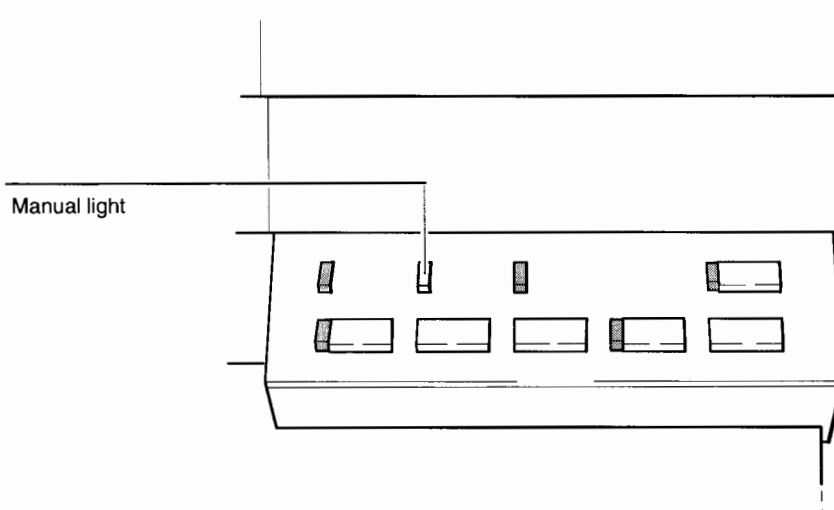

Paper/Print Cartridges light

The amber-colored Paper/Print Cartridges light tells you when the printer has a paper or print cartridge problem.

The light comes on when:

- The printer is out of paper.
- The printer has a paper jam. Remove the media tray and use the **Reverse** button to clear the problem. The **Reverse** button will not work unless the media tray is removed.
- The media tray is removed from the printer.
- At least one print cartridge is not installed or has a bad connection with the printer.
- At least one print cartridge has failed during print nozzle ink-flow testing.

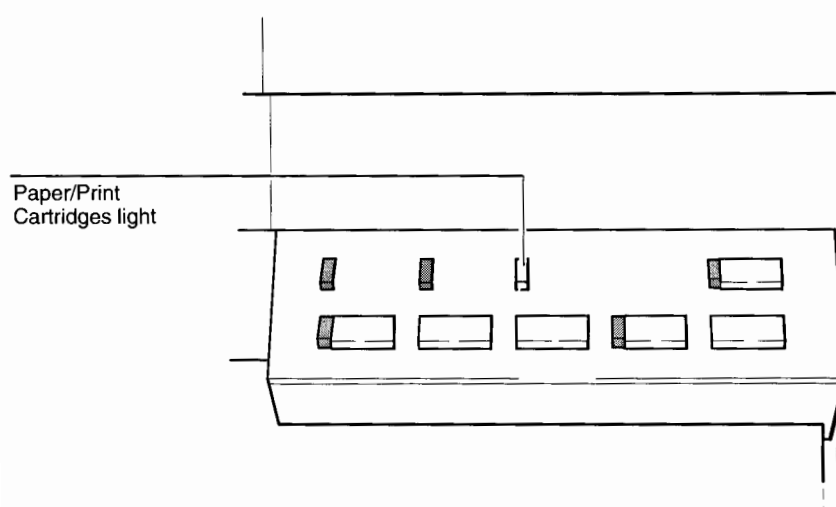

Control-panel features

To troubleshoot paper problems indicated by the Paper/Print Cartridges light, refer to the “Media problems” section of Chapter 7. To troubleshoot print cartridge problems, refer to the “Print cartridge problems” section of Chapter 7. To troubleshoot problems indicated by this light during initialization, refer to the “Printer operation problems” section of Chapter 7.



Using the rear-panel switches

This section describes how to use the switches to change your printer's settings. Once you set your printer's switches correctly, you will not need to reset them unless you change your computer/printer system so that it requires a different configuration. The default settings are shown on the next page.

To change a switch setting, refer to the following steps and illustration:

- 1 Turn off the Ready light by pressing the **Ready** button.
- 2 Push the switch to the desired position using a pencil or pen. The arrows indicate the direction to push the switch for that setting.
- 3 Turn on the Ready light by pressing the **Ready** button. The new switch settings are now in effect.

The printer reads the settings of the switches only when you initialize it.



Using your printer
Rear-panel switches

The illustration below shows the factory default settings.

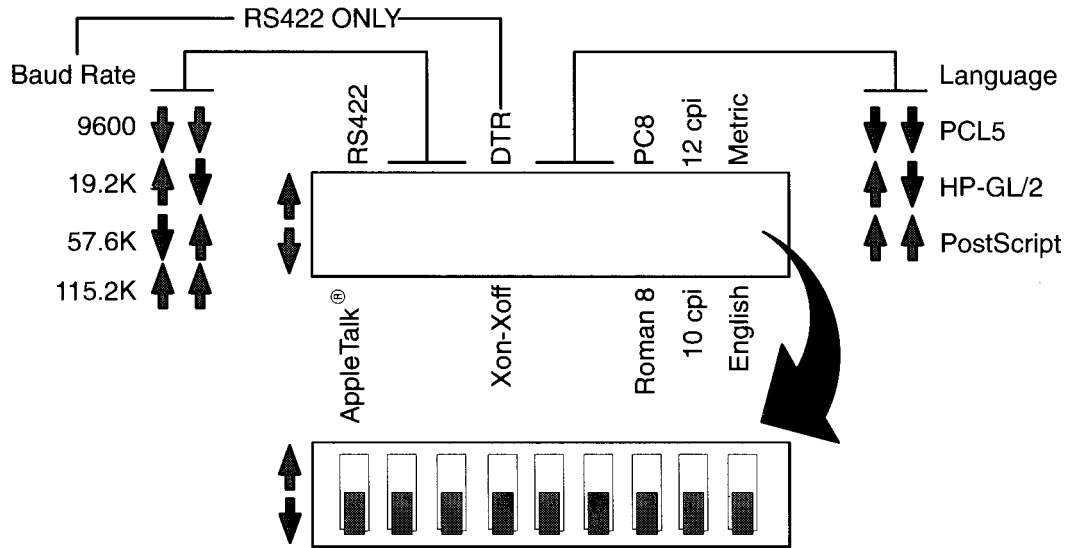

Switch settings are: AppleTalk, 9600, Xon-Xoff, PCL5, Roman 8, 10 cpi, and English.



Selecting AppleTalk or RS-422

You can select the I/O interface required by your computer by using the AppleTalk/RS-422 switch.

The illustration below shows the switch set to AppleTalk.

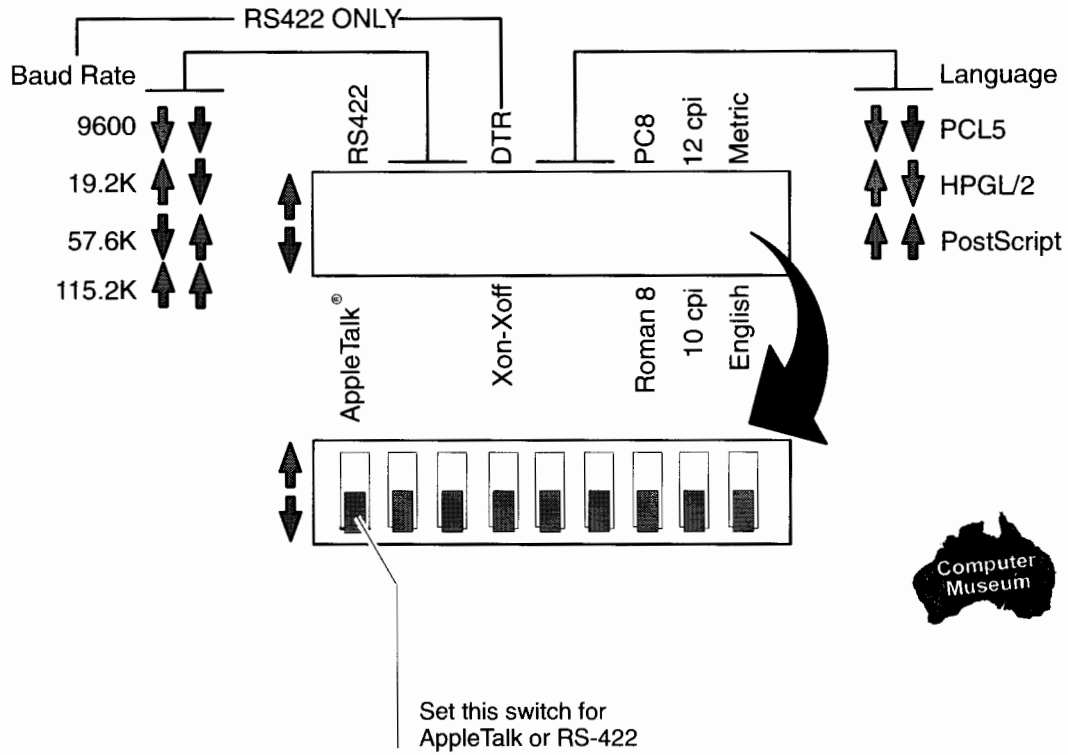

Selecting a baud rate and handshake

RS-422 only

Select the baud rate and handshake for the printer that is used by your computer or computer network.

The illustration below shows 57.6 k baud rate and Xon-Xoff handshaking.

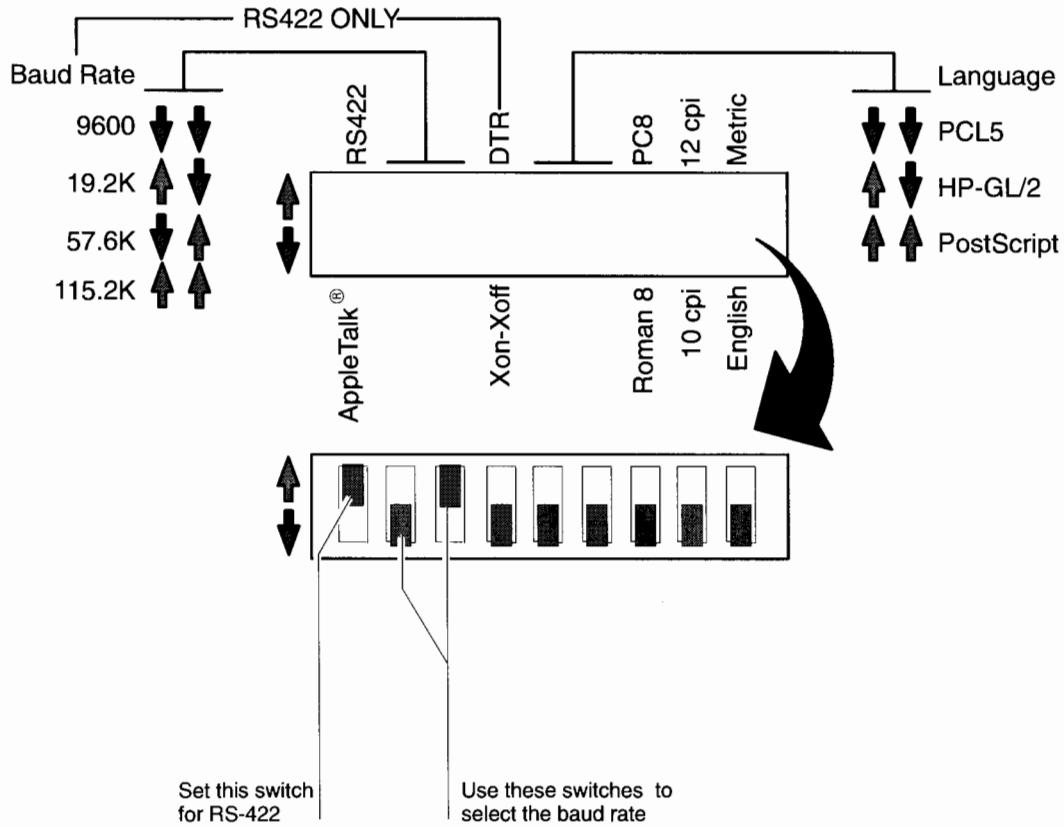

Selecting a printer language

The HP PaintJet XL300 supports three printer languages that control the basic operations of the printer:

- PCL5, the native (default) language.
- PostScript (valid only if PostScript option is installed).
- HP-GL/2, which allows for 'plotting' from CAD packages.

Two rear-panel switches allow you to control switching between PCL 5, HP-GL/2, and PostScript printer languages. When set, they take effect only after the printer is powered off and back on using the **Ready** button.

The rear-panel switches determine the default language in which the printer expects to receive instructions from your computer. However, some drivers contain switching commands that override the rear-panel switch settings.

If your PostScript and HP-GL/2 drivers contain software switching commands, you should leave the printer set to PCL5 and the printer will automatically switch to the language you are using. Older drivers do not contain these commands so you must select the language at the rear panel.

The HP-GL/2 option should be selected only for older software that does not contain commands to switch the printer into HP-GL/2 mode. If you have access to an initialization string for HP-GL/2, you can activate HP-GL/2 by sending **Esc%-1B**. If you do this then you do not need to set the Language switch on the rear panel to the HP-GL/2 setting.

If your software drivers do not contain switching commands and your printer's rear-panel switch settings are not set correctly, printing errors will result.



Using your printer
Rear-panel switches

Because system language switching causes a complete change to the way your printer interprets and processes data, it should be implemented and controlled on a network only by the network printer administrator.

The current system language can be changed by your software application or by another user if you are on a network or other shared printer environment.

The illustration below shows PCL5 language selected.

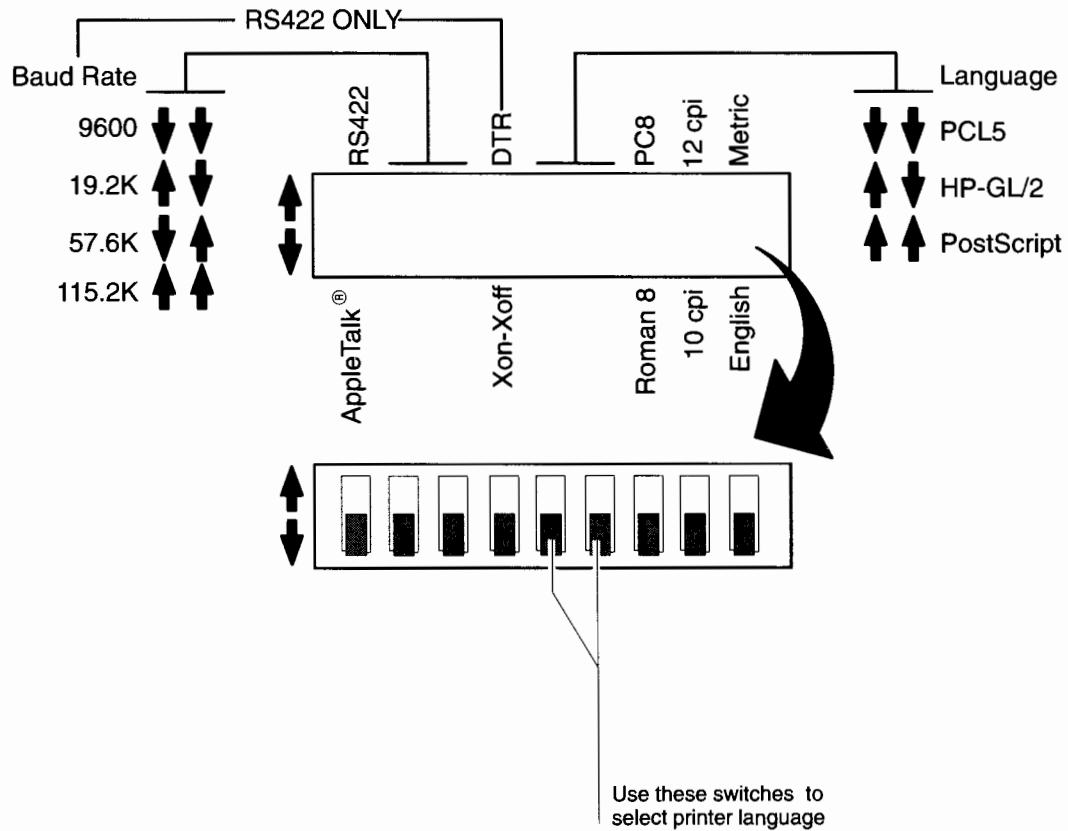

Selecting a default symbol set

For PCs, regardless of the interface or language you will be using, you must select either the Roman8 or PC8 symbol set to be the default set for your printer.

The Roman8 symbol set (factory default setting) includes the standard US ASCII set and the Roman Extensions, an 8-bit set of European characters and special symbols.

The PC8 set contains the same characters as the US ASCII set up to decimal value 127. Decimal codes 1–32 can have special printing characters if software graphically generates them or a transparent print data command is sent to the printer.

Decimal values 128–255 are 8-bit sets containing some European symbols and graphic symbols for mathematics and line drawing. It can be used with printing characters available on IBM personal computers, or when running software packages that support the PC8 set.



Using your printer
Rear-panel switches

Many software packages select a symbol set using PCL 5 commands that override the rear-panel switch settings.

The illustration below shows the Roman 8 symbol set selected.

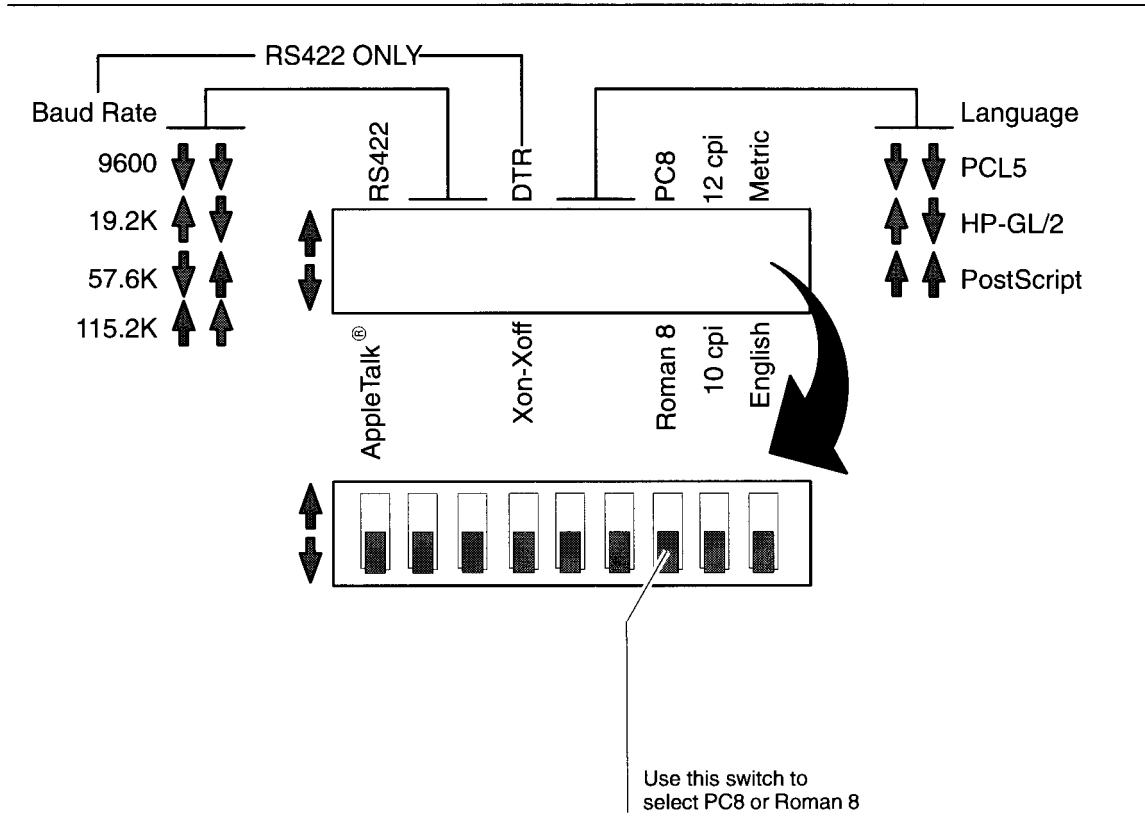

Selecting character spacing

The printer can print at 10 or 12 characters per inch (cpi). Use the 10 cpi/12cpi switch on the rear panel.

The illustration below shows the switch set to 10 cpi.

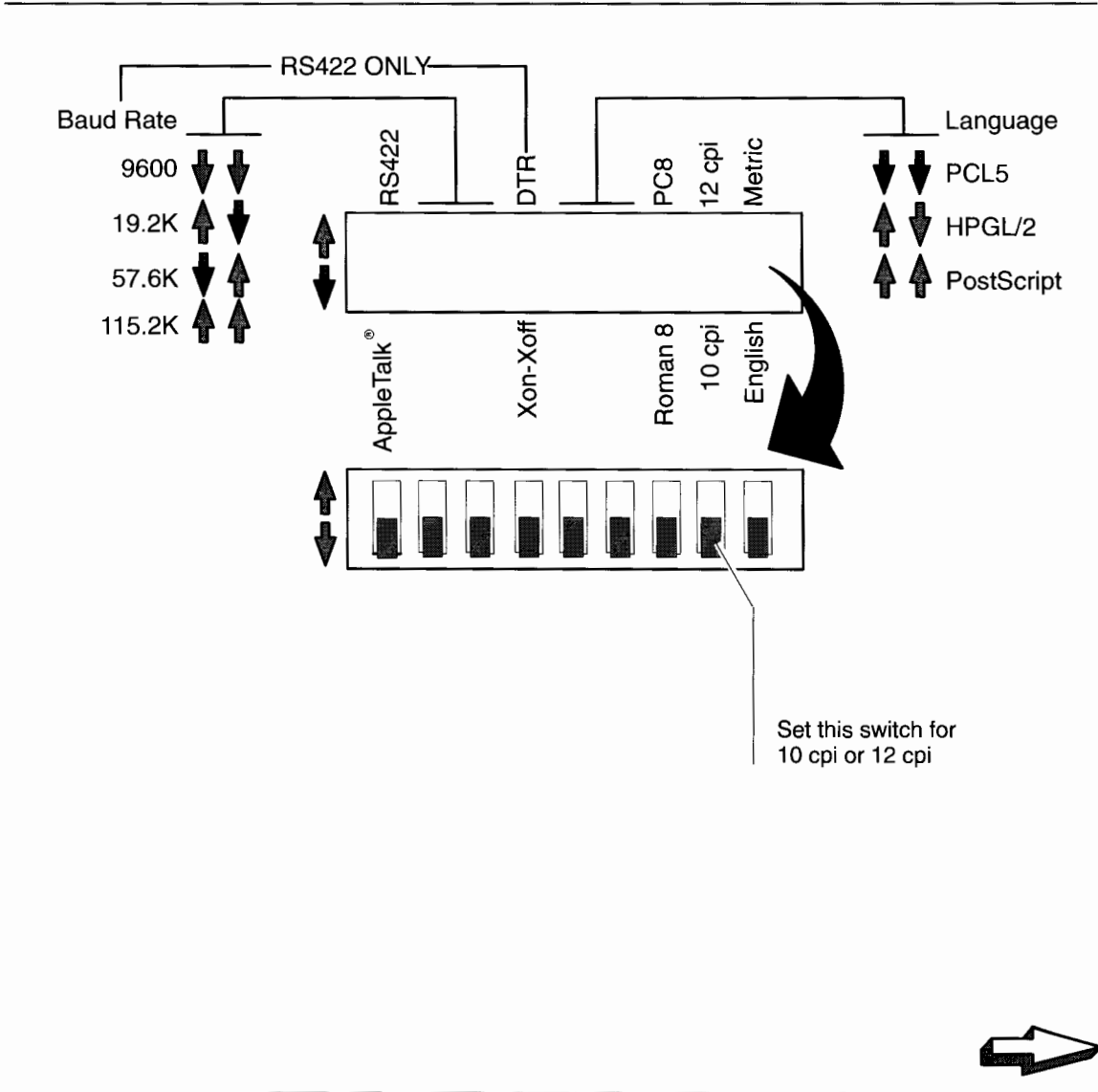

Selecting English or Metric media sizes



The printer is designed to use both metric and English paper or transparency film in the following standard sizes:

| English (ANSI) | Metric (ISO) |
|--------------------------|--------------------|
| A (8.5 by 11 in.) | A4 (210 by 297 mm) |
| B (11 by 17 in.) | A3 (297 by 420 mm) |
| US Legal (8.5 by 14 in.) | B4 (250 by 353 mm) |

You can configure the printer for English- or Metric-sized media by setting the rear-panel switch.

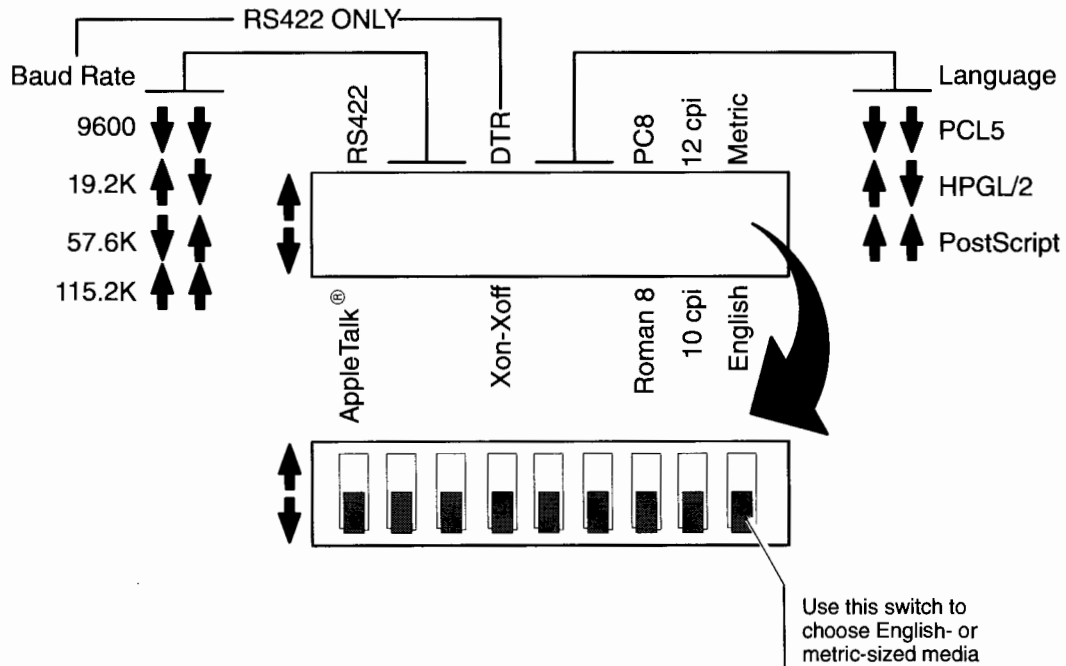
The illustration below shows the switch set for English sized media.



 Using software 

Using software

This chapter provides important information on using graphics software packages, word processors, spreadsheets, and other programs to create color graphics on your printer. Be sure to read it before using your software program. This chapter discusses the following topics.

- Getting ready to use your software
- Understanding drivers and resources
- Printing a file
- Setting margins with software
- Printing on transparency film or glossy paper
- Writing your own graphics program



Before you start

Your software documentation is your best source of information about how your software works and the features it supports. Sections of this chapter give you key words to look for in your application's manual for more information.

Many software packages require you to configure the software so that it knows what type of printer you are using, how the printer interface switches are set, and where the printer is attached to your computer. This configuration is usually done by typing or selecting answers on your computer in response to questions asked by the software. If your software asks you configuration questions, answer them carefully to avoid computer/printer communication problems. Read your software documentation when installing and configuring the software to avoid potential problems.

If your software documentation recommends specific printer settings, use them even if they differ from the settings recommended for your computer in chapter 3. If your software lists possible choices without making a recommendation, use the settings recommended in chapter 3.



Understanding drivers and resources

A driver (also called a resource) is a program that works with your software to transfer information from the computer to the HP PaintJet XL300 printer. Just as the cable is the link from the computer to the printer, the driver is the link from the software to the printer. You may be using one of two kinds of drivers:

- **Printer drivers** — Used on the basic DOS system. Every software package you use must provide a printer driver for your printer.
- **Environment drivers** — Used in the Macintosh and Windows environments. The environment driver comes with your printer and supports any software package that works in the environment. Your PaintJet XL300 comes with both a Windows and Macintosh environment driver. If you purchase the optional PostScript capability, you will receive PostScript Windows and Macintosh environment drivers.

How do drivers work?

Drivers control the printer by carrying information from your software package to the printer. The driver carries two types of information: the words, numbers, or graphics you wish to print and the instructions on how to print them (i.e., formatting instructions including paragraph breaks, margins, and enhancements, such as color, bold, or underline).

Drivers have two limitations: they carry only the information they are given by the software package and only the information they were designed to carry. Because of these limitations, you may be unable to use a feature of your software package or printer if the driver doesn't support it on your printer. The features you will be able to use are the ones that have all three components (software, driver, and printer).



DOS only

How do I get a printer driver?

The printer driver may come as part of your software package or may have to be obtained separately. In general, if an HP PaintJet XL300 driver is included, you will see the HP PaintJet XL300 listed in your software's 'select printer' screen. (When you 'select a printer', you are actually selecting a printer driver.)

If an HP PaintJet XL300 driver is not included in the installation directions for your application, check your application disk(s). Often software applications have a 'readme' file on the disk that contains information on using your printer with the software. List the directory of the disk and look for a file called 'readme' or a file name ending in '.DOC' or '.TXT'. To print the file, type the following at the DOS prompt:

print filename.extension

then press the **ENTER** key twice.

If you still can't locate an HP PaintJet XL300 driver or a PaintJet Series driver, contact your software vendor to see if one is available separately.

If an HP PaintJet XL300 driver is not available yet, here are your options:

- If you are doing office correspondence or black and white printing, the HP LaserJet IIISi or HP LaserJet IIIP drivers will work.
- For color printing, PaintJet or PaintWriter Series drivers will work.
- For technical or plotter drawings, HP-GL/2 drivers will work. Some of these drivers perform language switching within their software; others will not. If the driver you have does not perform language switching within its software, you must set the printer's rear-panel language switch to specify HP-GL/2 (refer to chapter 3).



Be aware that there are some differences between the PaintJet/PaintWriter and PaintJet XL300.

- The PaintJet XL300 emulates the 180 dpi resolution of the PaintJet/PaintWriter printers. To access the full 300 dpi resolution of the PaintJet XL300 you need to get a PaintJet XL300 driver.
- You may be unable to access all of PaintJet XL300's features using a PaintJet/PaintWriter driver.
- You may have some difficulty with margins.

Refer to *Setting Margins with Software* later in this chapter for more information on dealing with these differences.

If your software application has no HP PaintJet driver at all, you may still be able to use it with your HP PaintJet XL300 while waiting for your HP PaintJet XL300 driver to arrive. Printer drivers written for the HP LaserJet or HP DeskJet should give some ability to print although you won't be able to use the color capabilities of the printer.



Printing a file

Most software packages have a 'print' or 'output' command. Check your software manual for printing information. With many packages you can install a printer driver for more than one printer. If you are not getting the results you desire, check that the HP PaintJet XL300 is the printer being used to print your file. Usually there is a 'setup' or 'options' screen that lists the currently selected printer.

To print a file in DOS

- 1 Select the file you wish to print.
- 2 Select the HP PaintJet XL300 as the current printer. Refer to the install and/or setup instructions in your software manual.
- 3 Use the 'print' command to send the file to the printer.

To print a file in the Windows environment

- 1 Open the file you wish to print.
- 2 Select the HP PaintJet XL300 as the current printer using the Printer Setup option from the File menu.
- 3 Use the **Setup...** option on the Printer Setup dialog to set Color option, Media Size and Type, etc. Use the **Help...** button for assistance with the options.
- 4 Select **Print...** from the File menu to print the document.

To print a file in the Macintosh environment

- 1 Select the HP PaintJet XL300 as the current printer using the Chooser.
- 2 Open the file you want to print.
- 3 Use the Page Setup option from the File menu to set Media Size and Type. Use the Colors button on the Page Setup dialog to set Color options. Use the Help button (System 6.x) or Balloon Help (System 7.x) for assistance with the options.
- 4 Select **Print...** from the File menu to print the document.



Setting margins with software

Your printer has a text length of 60 to 64 lines depending on whether you use English or metric media. There is an unprintable region at the left, right, top, and bottom margins of the page. Refer to the chapter 2, "Using media and print cartridges," of this manual.

DOS only

If you are not using an HP PaintJet XL300 printer driver, you may need to adjust margins, page length, and/or header and footer positioning in order to get proper placement on the page.

If your printouts are not positioned correctly try these steps:

- In your software, specify the page length as 10 inches (254 mm) for letter size.
- You may need to set your footer to be printed farther above the bottom of the page than seems reasonable. This is because your software thinks the page is shorter than the actual page.

Obtaining the margins that you desire may require some experimenting with the top and bottom margin settings in your application.



Printing on transparency film or glossy paper

Be sure to select the appropriate media type when printing on transparency film or glossy paper. In transparency mode, the printer makes multiple printing passes to produce the intensity of ink needed for vibrant color.

If transparency or glossy media is available in your software package, select transparency mode through your application. Look under 'transparency' in your software's documentation. Since many software settings override printer settings, it is important to set the media from your software if possible.

If glossy media is not available in your software, use the transparency media setting.

If transparency mode is not available in your software, use the printer's Media button to turn on transparency mode. The Media light is lit orange when the printer is in transparency/glossy mode. Refer to "Using the control panel", in chapter 3 of this manual.

When finished, turn transparency mode off the same way you turned it on. Again, since many software packages will override the printer's setting, be sure that if you activated transparency mode with your software, you use your application to turn it off.



Writing your own graphics program

If you want to write your own graphics programs using the PCL programming language, you can purchase an extensive programming document package, the *PCL 5 Printer Language Technical Reference Manual* and *PCL5 Comparison Guide*, from Hewlett-Packard. Refer to the “Ordering information” chapter of this manual.

Since the HP-GL/2 Language Interpreter is built in, if you want to write your own graphics programs using the HP-GL/2 programming language, you can purchase an extensive programming document, the *HP-GL/2 Reference Guide* plus the *HP-GL/2 Comparison Guide* from Hewlett-Packard. Refer to the “Ordering information” chapter of this manual.

Although most graphics software packages allow you to specify the labels you need for your graphs, there may be occasions when you would like to add additional labels or graphics, for example, a company logo. The *HP-GL/2 Reference Guide* explains how you can write your own graphics programs that will add labels or graphics to software-generated graphs.





Using typefaces

Using typefaces

This chapter provides information about types of fonts, typeface cartridges, and PostScript typefaces. It also includes information about:

- Default typefaces
- Font rotation
- Disk-based typefaces
- Downloading typefaces
- Deleting disk-based typefaces from printer memory
- Typeface cartridge defaults



Default typefaces

Courier Portrait 10 pitch, 12 point (medium), is the typeface the printer uses unless you:

- Send a typeface selection command (using software or a printer command) to request a typeface in place of the default.
- Insert a typeface cartridge with a default typeface.

If two typeface cartridges are present and both have default typeface, the printer selects the left cartridge default typeface.



Font rotation

Whether or not the original font is in the orientation or print direction you want, the PaintJet XL300 printer can rotate type in 90° increments. Refer to the PCL print commands in the chapter titled “Technical information” in this manual.

Scalable typefaces can be rotated to any angle (degree) using HP-GL/2 commands.

Rotating a font uses more memory and may be slower than selecting a font already in the requested orientation.

A single portrait font automatically rotated using the print direction command is shown below.

PaintJet XL300
PaintJet XL300
PaintJet XL300
PaintJet XL300



Disk-based typefaces (PCL 5 only)

In the PCL 5 language, disk-based typefaces are bit-mapped fonts or scalable typefaces that can be transferred from disks to your printer. The process of transferring soft fonts from your computer to the printer is called downloading. Disk-based typefaces are sometimes referred to as downloadable typefaces.

Many optional HP disk-based typefaces and scalable typefaces are available. Contact your Hewlett-Packard sales representative or authorized dealer for purchasing information.



Downloading bit-mapped fonts and scalable typefaces

There are two ways to download typefaces:

- Using software.
- Using a utility provided by Hewlett-Packard.

Software packages vary in the kinds of typeface products they can download. Check the type section of your software manual for specific instructions.

If your software does not download typefaces for you, use one of these three methods to make the downloading process easy:

- Download from DOS.
- Use Type Director.
- Use FontLoad.

Downloading typefaces using MS-DOS

You can use DOS commands to download bit-mapped typefaces when no other software utility is available. Refer to *Downloading Your Soft Fonts*, a booklet that comes with bitmapped typefaces you purchase.



Downloading typefaces using Type Director

Type Director is Hewlett-Packard's font management program. Use Type Director to install scalable typefaces and prepare them for downloading. Type Director also helps you create high quality screen fonts to complement and enhance the capabilities of your software application.

Type Director is available on 3 1/2 in. and 5 1/4 in. diskettes in MS-DOS format. Disk-based scalable typeface products are available separately.

Unlike bit-mapped disk-based fonts, which can be simply copied to the printer, disk-based scalable typefaces require you use the Type Director program to prepare them for the printer.

Refer to the Type Director User's Guide, which provides complete instructions for installing scalable typeface products.

Downloading fonts using FontLoad

The FontLoad utility (HP part number 33407B), that comes with some Hewlett-Packard bit-mapped disk-based fonts, makes the downloading process very easy. Refer to your *FontLoad User's Manual* for complete instructions. You cannot download scalable typefaces with FontLoad.



Deleting disk-based typefaces from printer memory

The following printer commands delete typefaces from printer memory:

- **EC*c0F** – deletes all disk-based typefaces.
- **EC*c1F** – deletes all temporary disk-based typefaces.
- **EC*c#d** – specifies the Font ID#.
 EC*c2F – deletes the Font ID# specified.

Powering off the printer deletes all disk-based typefaces from memory.

You can also delete a disk-based typeface by overwriting it. If you load a disk-based typeface with the same ID# as an existing disk-based typeface, the existing typeface is overwritten in the printer's memory with the new typeface.



Disk-based typefaces hints

To operate your printer efficiently (especially where several users share a printer), consider the following:

- If your printer is connected to a network, be sure to check with your network printer administrator before downloading or removing disk-based typefaces and other typefaces.
- If the printer is shared, decide which disk-based typefaces to download and the ID numbers to assign to them. This helps avoid problems such as downloading duplicate typefaces or deleting typefaces needed by others.
- Powering off the printer deletes all downloaded disk-based typefaces. You must download them again to use them.
- The printer has a limited amount of memory in which to store typefaces. It takes time to download a disk-based typeface, and each occupies a portion of memory that cannot be used for anything else until you delete the typeface. Download only those typefaces you need and wait until you need others before you download again.
- If you use a large number of downloaded disk-based typefaces, or if you create and use very large typeface sizes, consider purchasing an optional printer memory card. This card expands the printer memory, allowing more typefaces to be stored.



Using typeface cartridges

Your HP PaintJet XL300 printer can use the entire range of HP LaserJet typeface cartridges. Your printer driver may provide support for different cartridges using the configuration menus of your software. Your software documentation may provide additional details for using the typefaces. Scalable typefaces are recommended for better document portability and versatility.

Typeface cartridges containing special typefaces developed by HP's Custom Products group are also available for custom software forms and logo packages.

In the U.S., contact the HP Custom Products group at **(208) 323-3684** for information about these cartridges.

In Europe, contact Hewlett-Packard GmbH at the address below:

Hewlett-Packard GmbH
PGE/ODS
Herrenberger Str. 130
7030 Boeblingen
Germany

Tel. (49)-7031-14-3785

Fax (49)-7031-14-1907

Refer to the "Technical information" chapter of this user's guide for data on bit-mapped fonts, symbol sets, and scalable typefaces.



Typeface cartridge defaults

If you have installed a typeface cartridge with a “default mark” (a mark in the typeface header that makes that typeface the default), the default-marked typeface will override the factory default typeface. The cartridge default will remain until you select different default using your software application, remove the cartridge, or insert a different default-typeface marked cartridge.



PostScript typefaces

PostScript contains 35 scalable typefaces drawn from 11 typeface families, all licensed from Adobe Systems, Inc. The PostScript language lets you bend, clip, rotate, scale, shape and stretch these typefaces. Check your software application manual for the exact capabilities of your software.

If you have an HP PaintJet XL300 without PostScript, you may order PostScript as an upgrade to your printer (refer to the “Ordering information” chapter of this manual).

Over 650 additional typefaces compatible with your printer are available from the Adobe Type Library. These typefaces can be purchased and used in your printer if you have the PostScript option installed.

You cannot use your PostScript typefaces in combination with typefaces resident in the HP PaintJet XL300 or with other typefaces supported by the PCL 5 printer language. Language switching allows you to use the PostScript or PCL-supported typefaces, but not both simultaneously.

Refer to the *PostScript Installation Guide* that came with your printer or your PostScript Upgrade Kit for more detailed information about PostScript typefaces. Refer to the *Adobe Type Manager User's Guide* for information on installing and using ATM typefaces.





Using color

Using color



Why use color?

When paperwork was produced only in black and white, readers who skimmed a document might miss the main points. Color adds value through:

- **Emphasis and Impact** — Highlights primary points. Your audience can focus on what's important.
- **Continuity and Interest** — Adds variety and renews interest. Color gives the eyes a break, dividing your document into sections.
- **Appearance and Professionalism** — Shows planning and preparation.



Color and your software

Your printer can print 16.8 million different colors. Your software determines the number you can use. Software generally supports all 16.8 million colors or:

- a limited number of colors, such as the basic eight (red, green, blue, cyan, yellow, magenta, black, and white).
- a limited number of colors, *PLUS* shades of those colors (shades are created by adding white to a color).
- a limited number of colors, *PLUS* the creation of custom colors, such as mixing red and blue for purple.



Matching screen and printed colors

Color occurs both on the screen and the printed page. In some software packages, the colors that are printed may not match the colors on the screen.

Although the Macintosh and Windows environment drivers have default screen-to-printer color matching, you may adjust your printed colors if the default has been modified.

In the Windows environment:

- 1 Select Control Panel
- 2 Select Printers
- 3 Select Configure
- 4 Select Setup
- 5 Select Options
- 6 Select Match to Screen box

In the Macintosh environment:

- 1 Use the Chooser to select the HP PaintJet XL300
- 2 Open the file you want to print
- 3 Select Page Setup from the File menu
- 4 Select Colors
- 5 Click the Adjust Printed Colors box
- 6 Click the Match Screen button



Importing color graphics

Some applications do not save color information. Thus a color graphic may lose its color when copied into another application.

When importing color graphics (for example, to merge text and graphics), you may have to experiment. Try these techniques.

- Use raster, 'bit-mapped' (.bmp) or 'paint-type' (.pcx), graphics when creating color graphics for merging.
- Try different graphics formats.

Many applications can save graphics in a variety of formats. Some formats, such as HP-GL/2, are more likely to retain color information than other formats.

- In the Windows environment, use the Clipboard to copy graphics from one application to another. The most you can copy to the clipboard at once is 64 kilobytes, so you may have to copy the drawing in parts.

Check the index of your software documentation under 'color', 'graphics files', and 'importing'.



Color best practices

Use color as a valuable tool, not a decoration. Using color to decorate the page can obscure the message. Color can explain, highlight, emphasize, lead the eye.

Color basics

Prioritize with color. Readers will look at the brightest area first.

Keep color choices simple. Four distinct colors are a practical maximum for the viewer to remember.

Be aware of your audience. Red has different connotations to bankers, politicians, and meteorologists.

Tips for best results

Reinforce color with shape. Make the red line on a chart wider, make the blue one dashed.

The larger the tinted area, the paler the color should be.

The smaller the color area, the stronger the color can be.

Beware of comparative brightness. Warm colors appear closer, cool colors farther away. Dark colors appear heavier.

Colors vary with their surroundings. The same color looks darker on a light background, lighter on a dark background, warmer on a cool background.

The light in which a color is viewed will affect how that color is perceived. A color may not look the same under sunlight as it does under incandescent light.



Using color

Colored text

Colored text

Bright colors tire the eye. Use them sparingly in text.

Make colored text larger and bolder. Color has lower contrast with white paper than black. Compensate by enlarging the area to be covered with colored ink.

Be sure that there is enough contrast between the text and its background.

| Background | Use | Avoid |
|------------|--------------------------|------------------------|
| Black | Green White Yellow | Blue Magenta Red |
| White | Black Blue Red | Cyan Yellow |



Presentations

Use color responsibly because readers are at your mercy.

Pointers for overhead transparencies

What works in print does not necessarily work in presentations.

Typefaces

Use:

- Solid block (sans serif).
- Two or three maximum.
- Larger for titles than text.
- Mainly 36 and 40-point typefaces.
- Upper and lower case letters instead of all capitals.
- Underlines, color, bold, or italics for emphasis.

Layout

- Leave generous margins around the outer edges.
- Start at the top-left corner (in left-to-right reading cultures).
- Place the most important information at the top.
- Be consistent in placement and spacing from slide to slide.
- Flush-left text is easier to read than centered
- Text and image should occupy about 3/4 of the space



Presentations

Color

- Keep bright and intense. What looks good in natural light may appear faded when projected.
- In dark rooms, use dark backgrounds (black, blue, grey, brown, green) with light colors for text. White is brighter on a dark background than other colors. Yellow is equally visible but a little aggressive.
- In light rooms, use pale backgrounds (white, pale green, pale blue, pale yellow, pale grey) with dark colors for text. Black, dark blue, brown, etc., read best. The best background is no color, so the screen blends into the surrounding.
- Three or four colors maximum
- Pretest a sample for projection quality
- Group arguments with color
- Use color to differentiate parts of a drawing
- Be consistent

Bulleted list

Guideline:

- 6 words per line
- 6 lines per slide
- 30 words per slide





Troubleshooting



Troubleshooting

This chapter contains information describing problems that you may encounter while using your printer, and how to recognize and correct them. This information includes:

- Maintaining your printer
- Print cartridge problems
- Media problems
- Printer operation problems
- Print quality problems
- Network problems
- Software application problems
- Returning your printer for service
- Getting help



Maintaining your printer

Maintenance of the printer is limited to periodic cleaning. Your printer performs best in a clean and dust-free environment. Observe the following environmental conditions:

- Operate only at temperatures from 60° to 86°F (15° to 30°C) and in relative humidity from 20% to 80%.
- Store at temperatures from -40° to 158°F (-40° to 70°C).

Perform the following maintenance procedure as necessary.

- **Exterior maintenance** —Use a soft lint-free cloth moistened with water to wipe dust, smudges, and stains off the printer's case.



Print cartridge problems

Important

The Paper/Print Cartridges light may indicate a print cartridge problem, or you may notice that one (or more) print cartridge is not printing.

If the amber-colored Paper/Print Cartridges light is on and you've already checked for paper problems (printer out of paper, paper jam, or removed media tray), you probably have one of the following print cartridge problems:

- At least one print cartridge is not installed or has a bad connection with the printer, or
- At least one print cartridge has failed during print nozzle ink-flow testing. (Occasionally, air bubbles or paper dust can clog one or more nozzles on a print cartridge.)

To correct these problems, first make sure that all four print cartridges are installed. Then remove the cartridges and check the print nozzles to make sure the protective tape has been removed. Finally, try one or both of the following instructions on fixing the bad connection or clearing the nozzles.

Try fixing the bad connection

Follow the steps below.

- 1 Open the cartridge cover.

Verify that all four cartridges are present and snapped into place.

Verify that the cartridges are not installed backwards.

Verify that all four cartridges have the correct part number. Only use cartridges with part numbers recommended in the "Ordering information" section of this manual.



- 2 Close the cartridge cover. If the Paper/Print Cartridges light turns off, the problem has been solved.
- 3 Open the cartridge cover, remove all four cartridges, then reinsert them. This will fix any cartridge that may have been seated incorrectly.
- 4 Close the cartridge cover. If the Paper/Print Cartridges light turns off, the problem has been solved.
- 5 Open the cartridge cover and remove all four cartridges.
- 6 Clean the interconnect surface on each cartridge by *gently* wiping the surface with a clean, dry, lint-free cloth or lens paper. Do not use cotton swabs or tissue.

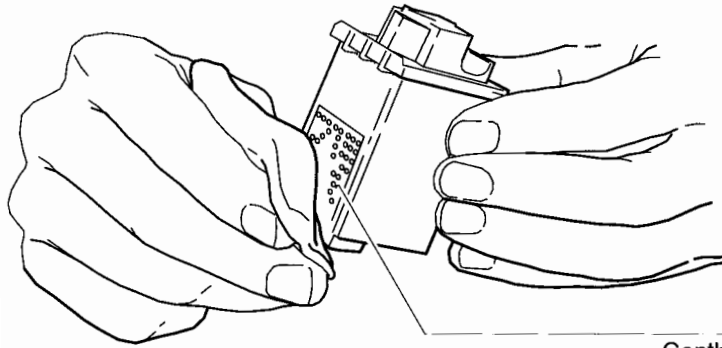

Gently clean the cartridge interconnect surface.



Troubleshooting
Print cartridge problems

- 7 Unplug the printer and clean the gold dimpled cartridge contacts on the printer. Clean by gently wiping the surface with a clean, dry, lint-free cloth or lens paper. Do not use cotton swabs or tissue.
- 8 Insert the cartridges back into the printer, close the cartridge cover, and plug in the printer.
- 9 If the problem still exists (Paper/Print Cartridges light is still turned on), try replacing one or more cartridges, then close the cartridge cover. If the Paper/Print Cartridges light is still turned on, your printer may need to be serviced. Refer to the "Getting Help" section later in this chapter.

Gently clean the dimpled cartridge contacts.

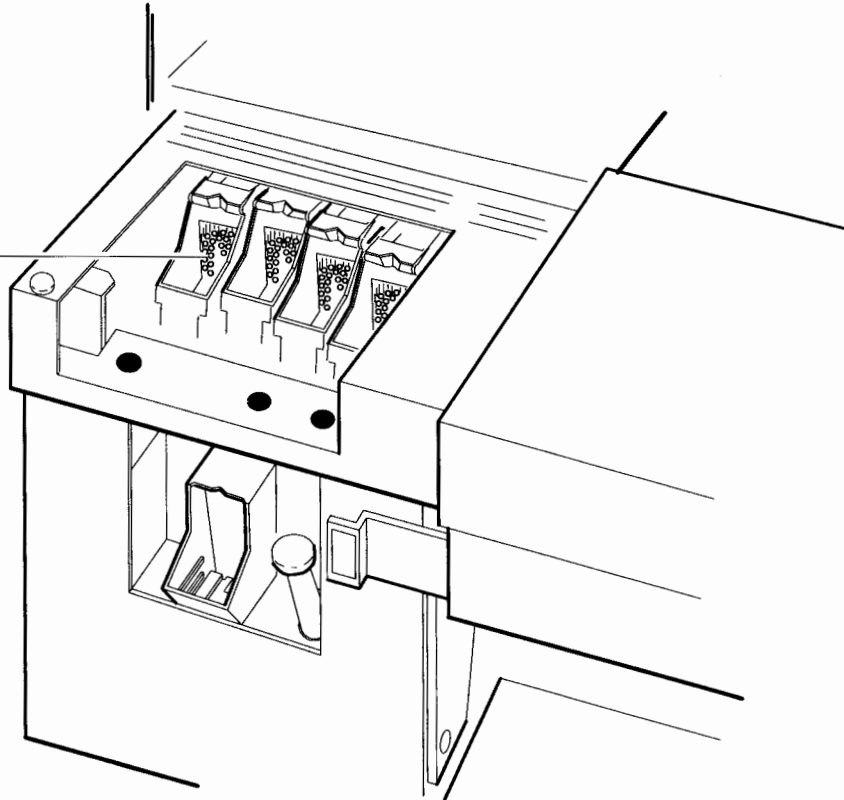

Clear the print cartridge nozzles

- 1 Look at your print output to see which cartridge (color) is printing incompletely, or press the **Test** button to run the self test.

A self-test sample is shown in step 7.

- 2 Lift the cartridge cover on the printer's front-left corner.

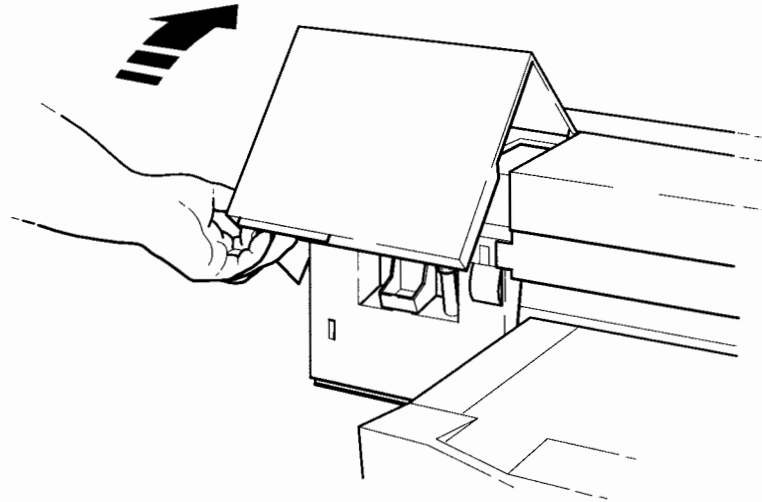

Troubleshooting

Print cartridge problems

- 3 Remove the faulty print cartridge from the cartridge carriage and insert it into the clearing station (insert and push forward to snap in).
- 4 Press the green clearing button once (all the way down), then release to clear the print cartridge.

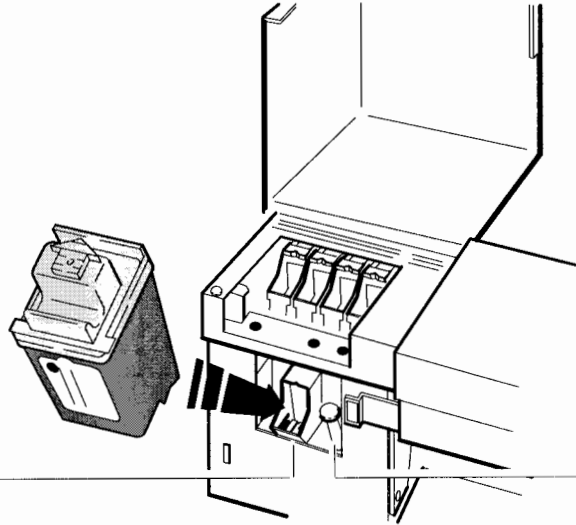

Clearing station

Green clearing button



- 5 Remove the print cartridge from the clearing station and replace it in the cartridge carriage.

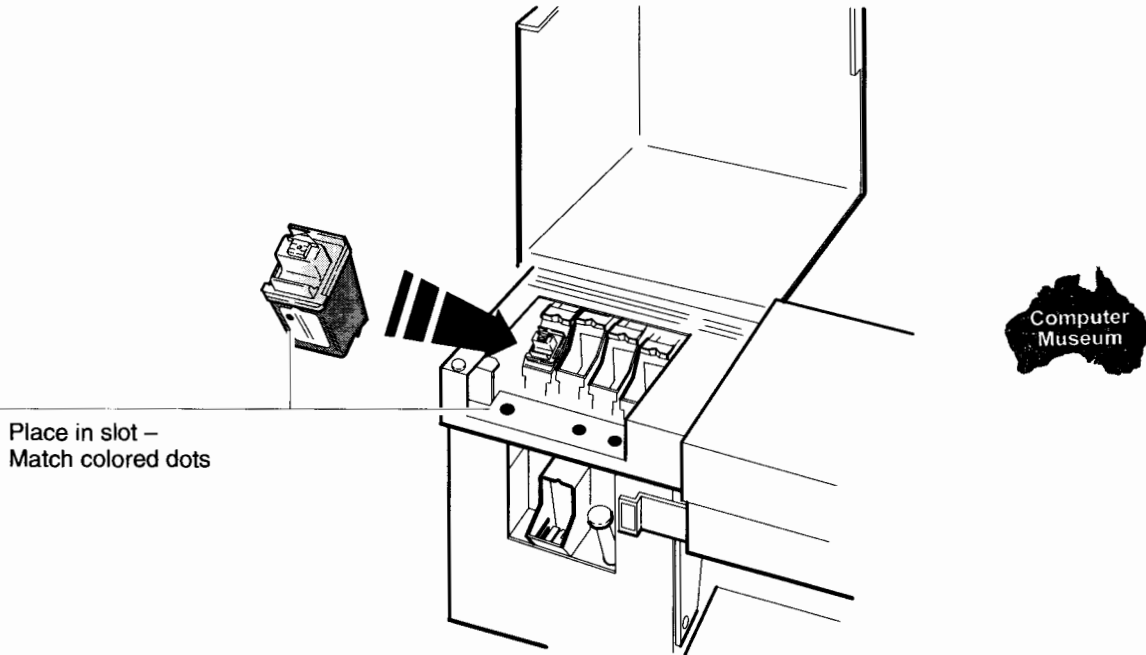

Troubleshooting
Print cartridge problems

Important

If you have the PostScript option, any downloaded PostScript fonts will be erased from the printer's memory when you perform the self test.

- 6 Press the **Test** button to start the self test and see if you've fixed the problem.
- 7 Compare your printing from the self test to the examples on the next page. Use this table to decide your next step.

| Result of Printing | Reason | Your Next Step |
|---------------------------------|--|--|
| A | Problem fixed. | Try using your printer again. |
| B (any color bar incomplete) | Cartridge out of ink or cannot unclog. | Perform steps 2 through 6 at least twice. If you cannot unclog the cartridge nozzles, replace the problem cartridge. Try using your printer again. |



Four color bars and lines on the self test should appear solid as shown below.
The intensity of the colors will vary depending on the type of media (bond paper, special paper, glossy paper) used.

Each bar is
a solid color

A

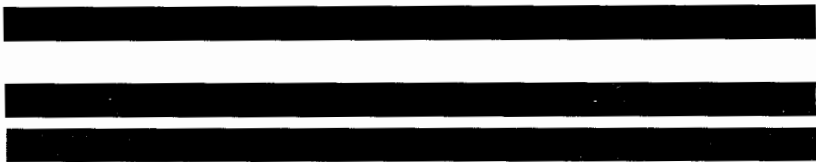

No gaps
appear in lines

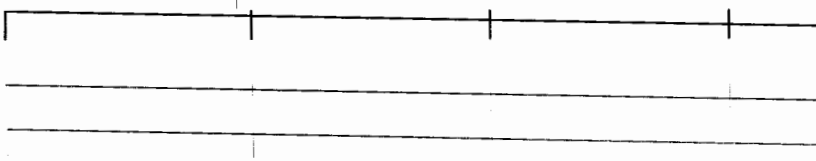

If any color bars or lines appear as shown below, the print cartridge nozzles may be clogged, and the corresponding cartridge needs to be cleared.

Streaks appear in
bars due to clogged
cartridge nozzles

B



Gaps appear
in lines

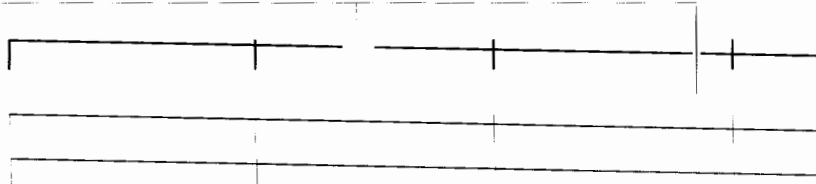

Media problems

When the amber-colored Paper/Print Cartridges light is on, one of the following three media problems may have occurred, or you might have a print cartridge problem (refer to the “Print cartridge problems” section earlier in this chapter):

- The printer is out of paper, or
- The printer has a paper jam, or
- The media tray is removed from the printer.

First make sure the media tray is loaded in the printer, then go through the following procedure.

1 Is paper correctly loaded in the tray?

No – Reload paper correctly. If necessary, refer to the HP PaintJet XL300 printer’s *Getting Started* guide for a detailed media loading procedure. Push the **Form Feed** button to continue printing.

Yes – Go to step 2.

2 Remove the paper tray and check for jammed media.

Is media jammed in the printer?

No – Refer to the “Print cartridge problems” section for other possible problems.

Yes – Use the **Reverse** button to remove the paper. Once the paper is removed from the printer, replace the tray. Push the **Form Feed** button to continue printing.



W A R N I N G

The rollers and heater grill inside the printer are hot. Allow the printer to cool before you attempt to remove media by hand or personal injury may occur.

C A U T I O N

Do not use tools to remove media from the printer. This may damage the roller surface.

If you cannot remove the paper using the **Reverse** button, try to pull the paper out gently by hand.



Printer operation problems

Use this section if the printer does not turn on or operate as you would expect.

- Printer does not initialize.
- Printer on but nothing prints.
- Carriage stops moving and all lights are flashing.
- HP PaintJet XL300 doesn't appear or can't be selected in the Chooser or Namer (Macintosh)
- Printer does not print the entire file or it will print incomplete portions of the file on more than one page (refer to Software application problems).

If the printer won't initialize

Initialization takes approximately 4 to 5 minutes to complete. At the start of initialization, the Ready light will turn on and the Busy light will flash. The printer allows time for internal rollers to warm up. The printer also clears left-over media in the print area, checks its print limits on each side, and checks the print cartridge alignment during this process. When the On Line light is on and the Busy light stops flashing, the printer has finished initializing.

If the printer can't initialize, control-panel lights will come on, or flash, in various groups and sequences. Use the table on the following page to try to find a solution to the problem. If you can't find a description for your particular sequence of light indicators, contact the HP Customer Support Center for help (refer to the "Getting help" section later in this chapter).



If the printer won't initialize and . . .

| Light Indications | Possible Problems | Solution |
|---|--|---|
| . . . the BUSY light is flashing while the PAPER/PRINT CARTRIDGES light is on steadily. | <p>The cartridge cover was raised during printer initialization.</p> <p>The media tray was not fully installed in the printer during printer initialization.</p> <p>Media was jammed in the printer during printer initialization.</p> | <p>Lower the cartridge cover, unplug the printer, count to 5, then plug in the printer.</p> <p>Install the media tray. Press the Ready button twice to reset the printer.</p> <p>Remove the media tray and press the Reverse button to remove the jammed media. If the media does not come out all the way using the Reverse button, gently pull the media from the printer.</p> |
| . . . the PAPER/PRINT CARTRIDGES and MEDIA (green or amber colored) lights are on steadily. | <p>There has been an irrecoverable print mechanism error. You will lose all data within the printer's buffer.</p> <p>The printer mechanism is too hot or too cold.</p> | <p>Unplug the printer, count to 5, then plug in the printer.</p> <p>Leave the printer alone for several minutes. Turn the printer off (Ready light off), then on. If the problem persists and you are printing within the recommended temperature and humidity environments, have your printer serviced.</p> |
| . . . the BUSY light is flashing. | The cartridge cover was raised before printer initialization started. | Lower the cartridge cover and the printer will begin initializing. |
| . . . the PAPER/PRINT CARTRIDGES light is on steadily. | <p>There's a bad electrical connection between the print cartridge and stall.</p> <p>There's a print cartridge missing.</p> <p>The wrong print cartridge was installed.</p> <p>At least one print cartridge is clogged, which caused an ink drop test failure during printer initialization.</p> | <p>Refer to the "Print cartridge problems" section earlier in this chapter.</p> <p>Make sure all stalls have cartridges.</p> <p>Only install print cartridges listed in the "Ordering information" chapter of this <i>User's Guide</i>.</p> <p>Refer to the "Print cartridge problems" section earlier in this chapter.</p> |
| . . . all lights are flashing. | <p>A print cartridge isn't fully inserted into the stall, causing the cartridge carriage to jam.</p> <p>Shipping cardboard was left inside the cartridge carriage area causing the cartridge carriage to jam.</p> <p>The cartridge carriage will not move.</p> | <p>Re-install the print cartridges. Press the Ready button twice to reset the printer.</p> <p>Remove the cardboard and load the print cartridges. Press the Ready button twice to reset the printer.</p> <p>Have your printer serviced.</p> |



Printer on but nothing prints

1 Check that:

- The On Line light is lit.
- All four print cartridges are installed (printer will not print if any of the print cartridges are missing).
- Nozzle tape has been removed from the print cartridges.
- The correct print cartridges are installed (refer to the “Ordering information” chapter in this manual). Again, the printer will not print if you have the wrong print cartridges installed.
- Media is loaded.
- Media is not jammed in the printer.

2 Is the Paper/Print Cartridge light on?

No – Go to step 3.

Yes – Go to the “Media problems” section of this chapter.

3 Check your rear-panel switch settings to ensure they are set properly. (Remember to turn the printer off and on (by pressing the **Ready** button) again after changing the switch settings).

4 Make sure you have the correct interface cable and that it is installed correctly.

If you suspect that the interface cable is bad, use another that you know is good. If the printer still will not print, have the printer serviced.



Carriage stops moving and all lights are flashing

1 Check that:

- The shipping cardboard in the cartridge carriage has been removed.
- All four print cartridges are installed (printer will not print if any of the print cartridges are missing).
- The correct print cartridges are installed (refer to the “Ordering information” chapter in this manual). Again, the printer will not print if you have the wrong print cartridges installed.

2 Remove the media tray and look inside the printer.

3 Is media jammed inside the printer?

No – Go to step 4.

Yes – If paper is jammed, remove the media tray and use the **Reverse** button to remove the jammed paper.

CAUTION

Do not use tools to remove media from the printer. This may damage the roller surface.

Gently remove the media by hand if it can be easily reached. Try using your printer again. Refer to the “Media problems” section of this chapter.

4 Make sure the printer is unplugged, then try moving the carriage with your hand.

Does the carriage move freely?

No – Have your printer serviced.

Yes – Turn the Ready light on by pressing the **Ready** button and try using your printer again.



HP PaintJet XL300 doesn't appear or can't be selected in the Chooser or Namer (Macintosh)

- 1 If the HP PaintJet XL300 icon doesn't appear in both the Chooser and the Namer:
 - Make sure the PaintJet XL300 printer resource icon is in the Extension System folder on your Macintosh computer.
 - Make sure that AppleTalk is active (the button next to 'active' in the Chooser is highlighted).

Try using your printer again.

- 2 If you can't select your PaintJet XL300 in both the Chooser and the Namer:
 - Make sure the printer is turned on (Ready and On Line lights are on).
 - Make sure the PaintJet XL300 printer resource icon is in the Extension System folder on your Macintosh computer.
 - Check to see that the LocalTalk cables and connector boxes are properly connected to each device.
 - Check to see that none of the pins in the interface connectors are bent, broken, or missing. Replace your interface cable or connector box if you find broken or missing pins.

After you locate and correct the problem, turn off your printer by pressing the **Ready** button. Wait a few seconds, then turn on your printer by pressing the **Ready** button again. Try using your printer again after it initializes.



Print quality problems

Check these, then read the situations for one that applies to you.

- Has the tape been removed from the nozzles of all four print cartridges?
 - Are all four print cartridges loaded correctly?
 - Are all four print cartridges *snapped* into place?
 - Have you followed the clearing instructions in the “Print Cartridge Problems” section of this chapter?
 - Is your printer operating within the proper environmental limits (refer to the “Technical information” chapter of this manual).
- 1 When printing, the left margin is shifted to the right; or the printer cuts off text and graphics before the right margin.

This can occur when you manually feed a sheet of paper and don't insert it exactly straight. If the media is skewed, the printer may erroneously establish a point along the top edge as one of the sides.

This problem can also occur if you do not have your software set correctly for the type of media you are using or if you have the wrong media size setting on the rear-panel switches.

- 2 You're using color in your document, but it prints black and white.

You may be using an application that has both color and black and white modes. If so, confirm that color mode is turned on (usually with a 'send color to printer' option) and try again. Also, you may be using a LaserJet driver which only has a black and white mode.

- 3 Ink tends to bleed on the media or the print seems fuzzy. The media has excessive cockling (wrinkled).

You may be using the wrong media. Use media that is supported and recommended by Hewlett-Packard.

You may not be printing within the specified environmental conditions. Refer to the section titled “Maintaining your printer” near the beginning of this chapter for the proper environmental range your printer should be operating in.



Network problems

Check that:

- Your printer is connected in a network configuration.
- You have selected the PaintJet XL300 Printer in the printer selection menu of your computer.

Erratic or interrupted network service

If your printer is printing erratically or is frequently interrupted while printing, a loop or an unattached cable may be in the network. Follow the cables through the network to find the problem.

This problem may also occur if your printer is connected to a very busy, active network. You may want to try connecting the printer directly to your Macintosh using LocalTalk cables. You can continue using the AppleTalk printer resource.

For HP JetDirect cards, the network uses T-connectors (shown below). Check that all T-connector ends are connected with a cable or a “terminator” (also called a dummy load, that makes the network think it has a cable connection). If a T-connector has an open end the entire network will be interrupted.

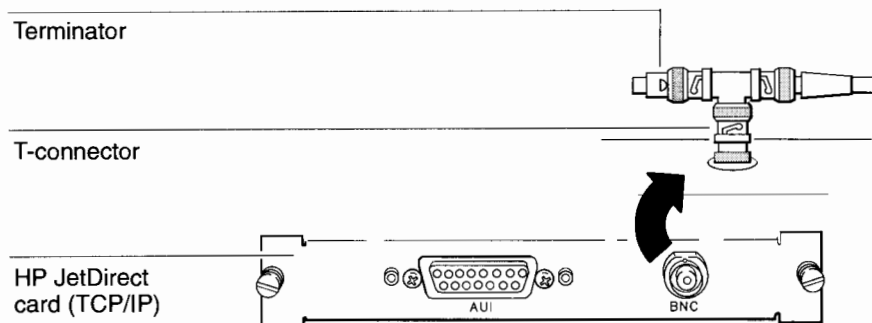

Software application problems

Macintosh

The Read Me file on PaintJet XL300 Disk 1 that came with the printer gives you specific information on many applications. Check the Read Me file to see if your application is covered.

- 1 I'm using Microsoft Word 3.02. When I choose Page Setup or Print from the File menu, I don't see the Paint Series printer dialog.

To access the Paint Series dialogs in Word 3.02, first press the Shift key, then pull down the File menu and choose Page Setup or Print.

- 2 Headers and footers are printed over the body of my document.

This sometimes happens in Microsoft Excel and Word 3.02. Try reducing your page length to fit between the header and footer or page number.

Windows/Macintosh

- 1 Sometimes my printer does not print my entire file.

Your file is too large for the printer's memory. A message indicating insufficient memory will be printed at the bottom of the page. If your file takes up more memory than your printer contains, additional memory can be added to the printer. Refer to the "Ordering information" section of this User's Guide to order additional SIMM memory.



Returning your printer for service

If your printer requires service, contact the Hewlett-Packard dealer or HP Sales and Support Office where you purchased the printer.

If you need to ship your printer, be sure it is packed in a protective carton. We recommend that you save the original shipping container for this purpose. In-transit damage is not covered by the warranty, so you should always insure your shipment.

You can help assure effective servicing of your printer by following these guidelines:

- 1 Follow the troubleshooting instructions in this chapter to make certain the problem is in your printer and not the result of configuration problems or a malfunction in your computer or software. If possible, identify the defective function.
- 2 If you decide that repair is required, please include these items when returning the printer.
 - The power cord.
 - A description of the exact configuration at the time of the problem, including the interface cable, computer and peripherals, and software in use.
 - A brief description of symptoms for service personnel (samples of print quality problems are helpful).
 - If purchased through an HP dealer, a copy of the sales slip or other proof of purchase to establish the warranty coverage period.
 - Your name, address, and a phone number where you may be reached during the day.



Getting help

Hewlett-Packard has support services available to help you in case you have a problem with your HP PaintJet XL300 printer. Following are suggestions of places to turn for this support.

Before you call for customer support, make sure you do the following:

- 1 Review this “Troubleshooting” chapter.
- 2 Perform the built-in self test in step 6 of the “Print cartridge problems” section of this chapter.
- 3 Make sure you are using the correct interface cables and rear-panel switch settings, as explained in Chapter 3.
- 4 Check with your software vendor for help.

If you still have difficulty, begin by contacting the person who sold you your HP PaintJet XL300. Your sales representative or dealer is familiar with your needs, equipment, and software and should be able to provide you with the information you want.

If you don't get the answers to your questions from your dealer or sales representative, you may contact HP's Customer Support Center. The Customer Support Center staff can provide you with help by answering questions on your printer or accessories supplied with your printer.



Troubleshooting

Getting help

When you call the HP's Customer Support Center line, please have the following information available to help us answer your questions more quickly.

- Identify what computer you are using and printer serial number.

- Identify any special equipment or software you are using (for example, spoolers, networks, switch-boxes, modems, or special software drivers).

- Identify what cable you are using (by part number) and where you purchased it.

- Identify the interface you are using with your printer (AppleTalk, serial, parallel, RS-422) and any extra options (memory, PostScript, typeface cartridges).

- Identify the printer driver name and version, and software application name and version you are currently using.

The HP Customer Support Center service is available from 7 am – 6 pm (Mountain Standard Time), Monday through Friday, except Wednesday when we close at 4 pm.

(208) 323-2551

Should the printer require service, refer to “Returning your printer for service” section of this chapter for instructions.





Installing printer options



Installing printer options

This chapter provides information on expanding the capabilities of your HP PaintJet XL300 printer. Procedures include:

- Installing additional memory
- Installing typeface cartridges



Installing the memory card

CAUTION

Because the memory expansion card contains parts that are easily damaged by small amounts of static electricity, you need to take precautions such as using grounding devices and maintaining contact with any bare metal surface on the printer while handling the memory expansion card. Handle the card carefully at all times. Avoid touching the card components or circuit paths. Be sure to replace the memory expansion slot cover after installing the memory card to prevent dust from accumulating inside the printer.

- 1 Turn off the printer by removing the power cord.
- 2 Remove the memory expansion slot cover.

Pull the tabbed portion slightly outward, then rotate upward and remove.

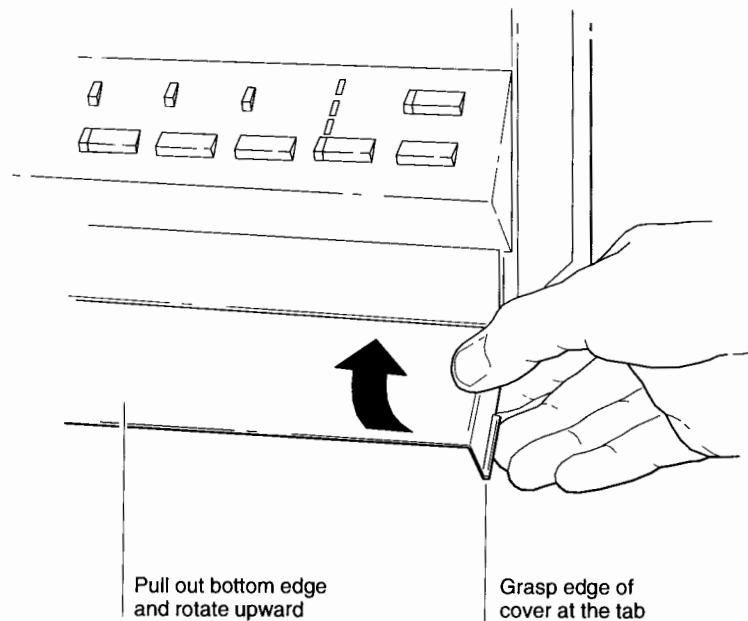

Memory

- 3 Open the memory expansion kit and remove the memory expansion card and SIMM card.
- 4 Install the SIMM card vertically onto the memory expansion card, then adjust the SIMM card to a 45° angle to the memory expansion card.

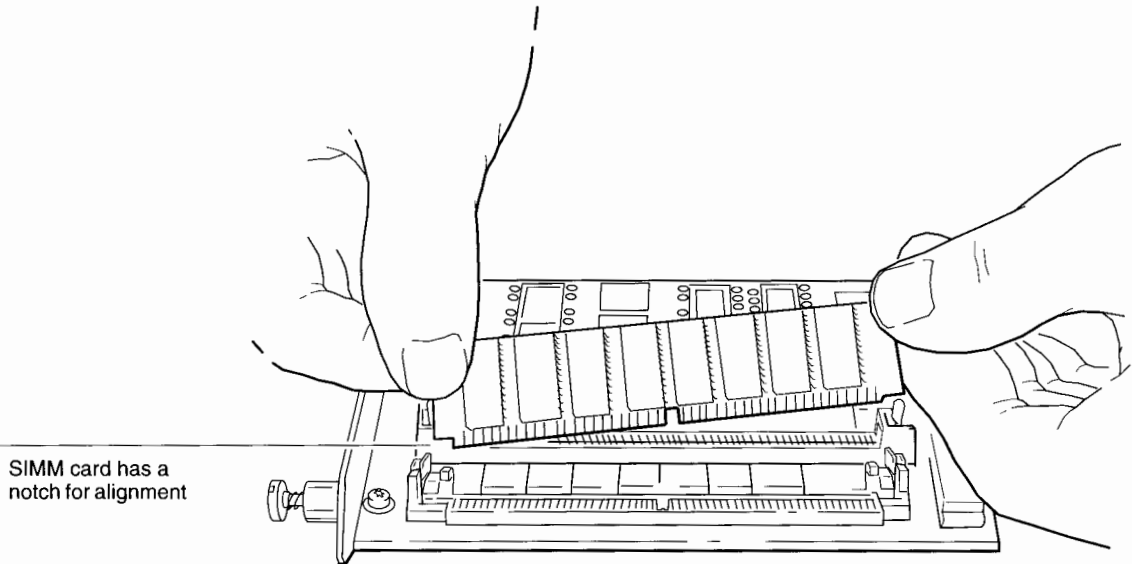

SIMM card has a notch for alignment

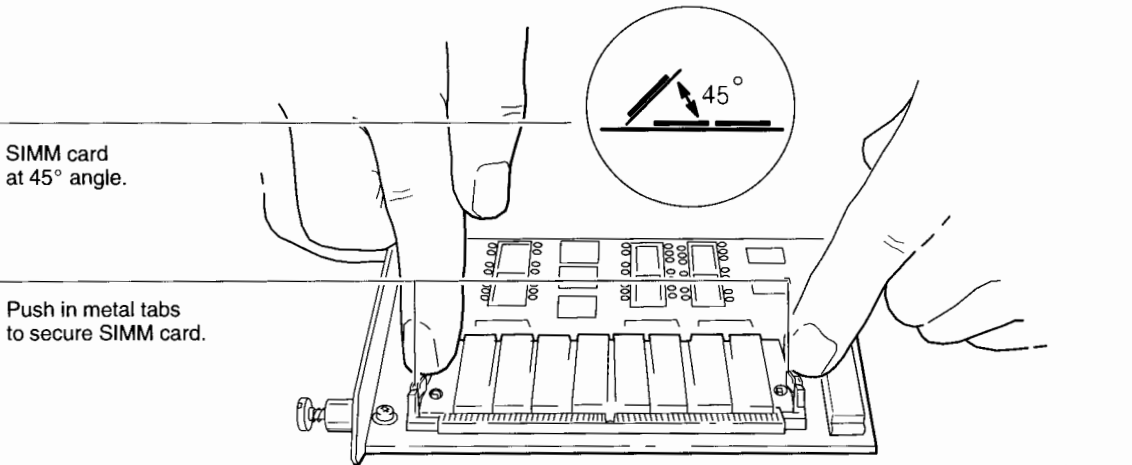

SIMM card at 45° angle.

Push in metal tabs to secure SIMM card.



- 5 Insert the card into the memory expansion slot (use the guide rails shown in the illustration below).

Be sure the card is seated firmly into the connector in the slot.

Slide in along rails

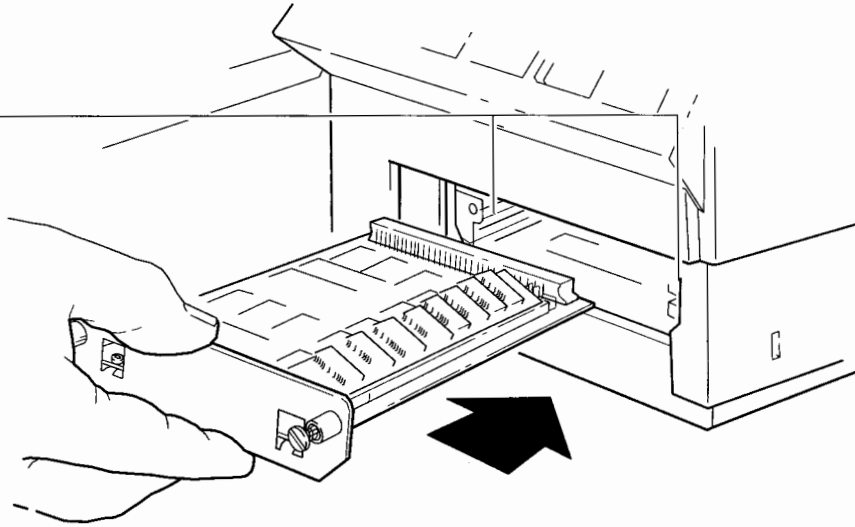

Memory

- 6 Secure the memory expansion card to the printer by tightening the two thumb screws.
- 7 Replace the memory expansion slot cover.

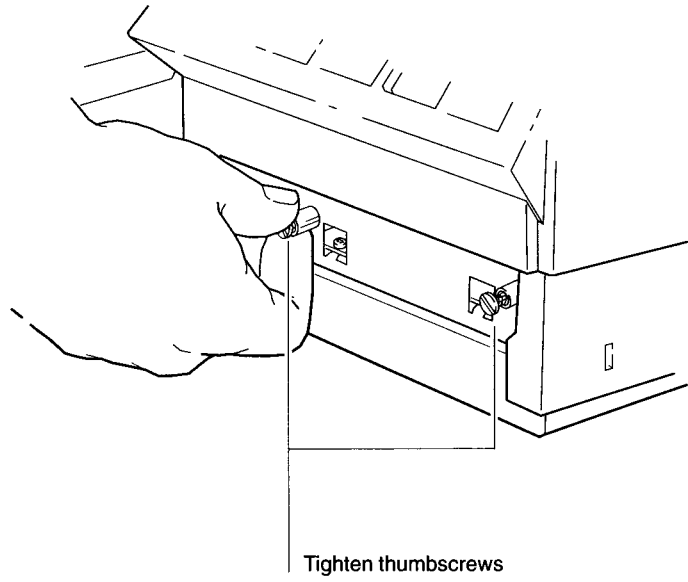

Installing a typeface cartridge

- 1 Turn the printer off by pressing the **Ready** button (Ready light is off).
 - 2 Remove the media tray.
 - 3 Insert the typeface cartridge into one of the slots as shown below.
Push firmly until the cartridge is in place.
 - 4 Insert the media tray.
 - 5 Turn the printer on by pressing the **Ready** button.
 - 6 Print a self test to check installation (look under the “Accessories” section).
-

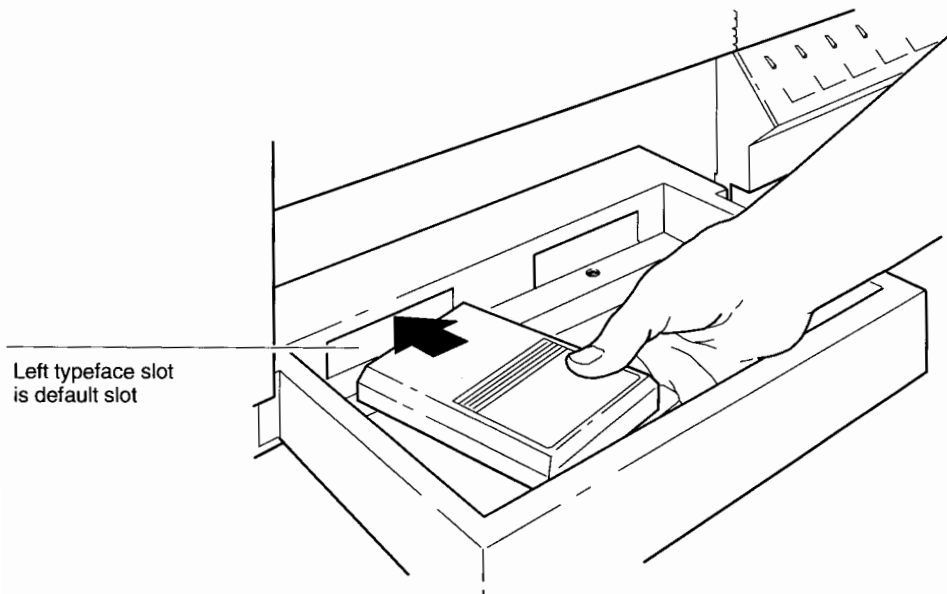

Left typeface slot
is default slot





Technical information



Regulatory notices

FCC Statement
(U.S.A.)

The United States Federal Communications Commission (in 47 CFR 15.838) has specified that the following notice be brought to the attention of users of this product.

'This equipment has been tested and found to comply with the limits for a Class B digital device, pursuant to part 15 of the FCC Rules. These limits are designed to provide reasonable protection against harmful interference in a residential installation. This equipment generates, uses and can radiate radio frequency energy and, if not installed and used in accordance with the instructions, may cause harmful interference to radio communications. However, there is no guarantee that interference will not occur in a particular installation. If this equipment does cause harmful interference to radio or television reception, which can be determined by turning the equipment off and on, the user is encouraged to try and correct the interferences by one or more of the following measures:

- reorient the receiving antenna
- increase the separation between the equipment and the receiver
- connect the equipment into an outlet on a circuit different from that to which the receiver is connected
- consult the dealer or an experienced radio/TV technician for help

The user may find the following booklet prepared by the Federal Communications Commission helpful: How to Identify and Resolve Radio-TV Interference Problems. This booklet is available from the US Government Printing Office, Washington, DC 20402, Stock No. 004-000-00345-4.'

CAUTION

Pursuant to Part 15.21 of the FCC Rules, any changes or modifications to this equipment not expressly approved by the Hewlett-Packard Company, may cause harmful interference and void the FCC authorization to operate this equipment.

Installing any network peripheral interface card in an FCC Level B product results in an FCC Level A Composite System as defined in the FCC Rules and Regulations.



| | |
|--|--|
| Telecommunications General Approval (UK) | Pursuant to Section 22 of Telecommunications Act of 1984 this product is approved for secondary attachment to approved primary attachment devices connected to the telecommunication network under the General Approval (NS/G/1234/5/100003). |
| DOC statement (Canada) | <p>Le present appareil numerique n'emet pas de bruits radioelectriques dépassant les limites applicables aux appareils numeriques de la class B prescrites dans le Reglement sur le brouillage radioelectrique edicte par le ministere des Communications du Canada.</p> <p>This digital apparatus does not exceed the Class B limits for radio noise emissions from digital apparatus set out in the Radio Interference Regulations of the Canadian Department of Communications.</p> |
| Geräuschemission | LpA < 70 dB am Arbeitsplatz im Normalbetrieb nach DIN 45635 T. 19 |
| VCCI-2 | <p>この装置は、第二種情報装置（住宅地域又はその隣接した地域において使用されるべき情報装置）で住宅地域での電波障害防止を目的とした情報処理装置等電波障害自主規制協議会（VCCI）基準に適合しております。</p> <p>しかし、本装置をラジオ、テレビジョン受信機に近接してご使用になると、受信障害の原因となることがあります。</p> <p>取扱説明書に従って正しい取り扱いをして下さい。</p> |
| Korean EMI | 이 기기는 업무용으로 전자파장애검정을 받은 기기이오니 판매자 또는 사용자는 이점을 주의하시기 바라며, 만약 잘못 구입하였을 때에는 구입한 곳에서 비업무용으로 교환하시기 바랍니다. |



Declaration of conformity

| DECLARATION OF CONFORMITY according to ISO/IEC Guide 22 and EN 45014 | |
|--|---|
| Manufacturer's Name: | Hewlett-Packard Company |
| Manufacturer's Address: | 16399 West Bernardo Drive San Diego, California U.S.A. 92127 |
| declares that the product | |
| Product Name: | HP PaintJet XL300 Printer |
| Model Number: | HP C1645A & HP C1656A (PostScript version) |
| Product Options: | C1651A PostScript Kit C2059* Ethernet Card (2) C2059* Token Ring Card (2) |
| conforms to the following Product Specifications: | |
| Safety: | EN60950 / UL1950 / CSA 22.2 No. 950 EMKO TUE(74)DK203/91 |
| EMC: | EN 55022 (1988) / CISPR 22, Class B (1) prEN 55101-2 (1990), 3kV CD, 8kV AD prEN 55101-3 (1990), 3 V/m FCC Part 15 Class B DOC B VCCI-2 |
| Supplementary Information: | (1) The C1645A was tested in a typical configuration using a Hewlett-Packard Personal Computer. (2) * may be A through F. These options exhibit Class A operation. |



Functional Specifications

| Feature | Specifications |
|-------------------------------|--|
| Print Rate | 16.7 in/sec (424 mm/sec) Black & white: 1–2 min/page (mpp) Color: 1.5–6 mpp |
| Printable width (8 inches) | 80 characters at 10 cpi 96 characters at 12 cpi |
| Form Feed Rate | 8 seconds per 11-inch page |
| Print Modes | Unidirectional and bidirectional text printing Unidirectional color printing Transparency printing Fast printing |
| Buffer size | 2 Megabytes (standard) expandable to 18 Megabytes |



Functional Specifications, Continued

| Feature | Specifications |
|------------------|--|
| Media Sizes | HP CX JetSeries CutSheet Paper: A-size (8.5 × 11 in.) A4-size (210 × 297 mm) B-size (11 × 17 in.) A3-size (297 × 420 mm) Japanese International Standard B4-size (257 × 364 mm) HP LX JetSeries Transparency Film: A-size (8.5 × 11 in.) A4-size (210 × 297 mm) HP LX JetSeries Glossy Paper: A-size (8.5 × 11 in.) A4-size (210 × 297 mm) |
| Resolution (dpi) | 300 dpi, horizontal and vertical |
| Dot Spacing | 0.0033 in. (center to center) |
| Text Colors | Up to 16.8 million |



Environmental Specifications

| Feature | Specifications |
|-----------------------------|------------------------------|
| Operating Temperature | 60° to 86°F (15° to 30°C) |
| Operating Relative Humidity | 20 to 80% (at 15° to 30°C) |
| Storage Temperature | -40° to 158°F (-40° to 70°C) |

Physical Specifications

| Feature | Specifications |
|---------|--|
| Size | 30 in. by 20 in. by 10 in. (762 mm by 508 mm by 254 mm) including paper tray |
| Weight | 45 lb (20.41 kg) |



Specifications

Power Specifications

| Feature | Specifications |
|----------------|------------------------|
| Source | 100 to 240 V \pm 10% |
| Frequency | 48 to 63 Hz |

Product Certifications

| Feature | Standard |
|----------------|---|
| Safety | UL1950 CSA 22.2 #950 EMKO TUE(74)DK203/91 IEC 950 EN 60950 |
| EMI | FCC Class B VCCI-2 EN 55022 prEN 55101-2 prEN 55101-3 Doc. B |



Bitmapped fonts

| Typeface | Pitch | Point | Treatment | Orientation* |
|--------------|-------|-------|-----------|----------------------|
| Courier | 10 | 12 | Medium | Portrait & Landscape |
| Courier | 10 | 12 | Bold | Portrait & Landscape |
| Courier | 10 | 12 | Italic | Portrait |
| Courier | 12 | 10 | Medium | Portrait & Landscape |
| Courier | 12 | 10 | Bold | Portrait & Landscape |
| Courier | 12 | 10 | Italic | Portrait |
| Line Printer | 16.67 | 8.5 | Medium | Portrait & Landscape |

* Bitmapped fonts are provided in the printer for orientations listed. For those orientations not listed, the printer will autorotate the font if those orientations are requested.

Scalable Typefaces

| Typeface | Treatment |
|-------------------|-----------------------------------|
| CG Times | Medium, Bold, Italic, Bold Italic |
| Univers | Medium, Bold, Italic, Bold Italic |
| Univers Condensed | Medium, Bold, Italic, Bold Italic |
| ITC Zapf Dingbats | Medium |



**Internal symbol sets
(scalable typefaces and bitmapped fonts)**

| Symbol set | Symbol set (continued) |
|------------------------------|-------------------------------|
| Roman-8 | ISO 11 Swedish: names |
| ISO 8859/1 Latin 1 (ECMA-94) | ISO 21 German |
| PC-8 | ISO 17 Spanish |
| PC-8 Danish/Norwegian | ISO 69 French |
| PC-850 | ISO 15 Italian |
| ISO 6 ASCII | ISO 60 Norwegian v1 |
| Legal | ISO 4 United Kingdom |



Internal symbol sets (scalable typefaces only)



| Symbol set | Symbol set (continued) |
|-----------------------|-------------------------------|
| Windows | PS Math |
| DeskTop | Pi Font |
| Ventura International | Ventura ITC Zapf Dingbats* |
| PS Text | PS ITC Zapf Dingbats* |
| Ventura US | ITC Zapf Dingbats Series 100* |
| Microsoft Publishing | ITC Zapf Dingbats Series 200* |
| Math-8 | ITC Zapf Dingbats Series 300* |
| Ventura Math | |

* These can be used only with the ITC Zapf Dingbats typeface.

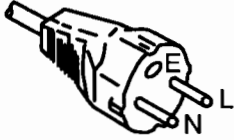

Power cord options

The power cord supplied with your printer should match the plug requirement for your area. However, power cords with different plugs (international options) are available and are shown in the following chart. If you wish to use a different power cord, contact your local Hewlett-Packard dealer or Sales and Support Office.

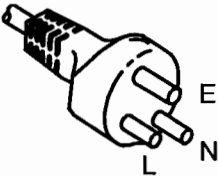
| AC Plug Type* | AC Voltage | Country | HP Part Number |
|--|----------------|--|----------------|
|  CEE 7-VII | 220 or 240 V | Europe Egypt Saudi Arabia | 8120-1689 |
|  ASC112 | 220 or 240 V | Australia New Zealand | 8120-1369 |
|  | 220 V 240 V | Republic of South Africa India | 8120-4211 |

* L = Line or Active Conductor (also called "live" or "hot")
 N = Neutral or Identified Conductor
 E = Earth or Ground

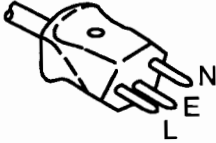
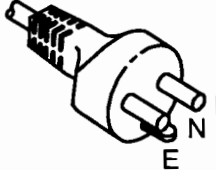
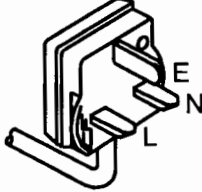
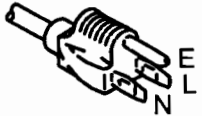

| AC Plug Type* | AC Voltage | Country | HP Part Number |
|--|--------------|---|------------------------------------|
|  SEV 1011 | 220 or 240 V | Switzerland | 8120-2104 |
|  DHCK-107 | 220 or 240 V | Denmark | 8120-2956 |
|  BS 1363A | 220 or 240 V | United Kingdom | 8120-1351 |
|  NEMA 5-15P | 100 or 120 V | Canada Mexico Philippines Taiwan United States Japan | 8120-1378 8120-4753 |

* L = Line or Active Conductor (also called "live" or "hot")
 N = Neutral or Identified Conductor
 E = Earth or Ground



To obtain a Material Safety Data Sheet (MSDS)

You can obtain a current Material Safety Data Sheet for the ink cartridges used in the HP PaintJet XL300 printer (HP part number C1645A) in one of the following ways.

- By calling the U.S. Hewlett-Packard Customer Information Center at the following number:

(800) 752-0900 Ask for Department MSDS,
6 am to 5 pm Pacific Standard Time (PST)

- By mailing a request to this address in the USA:

Hewlett-Packard Customer Information Center
19310 Pruneridge Avenue, Dept. MSDS
Cupertino, CA 95014

- By mailing a request to this address in Canada:

HP Canada
Attn: MSDS Request
2670 Queensview Drive
Ottawa, Ontario K2B8K1

- By using HP First: 208-344-4809. Call from a Group 3 facsimile machine and request index #4401.



Centronics cable schematics

The following cable schematics are for Hewlett-Packard cables.

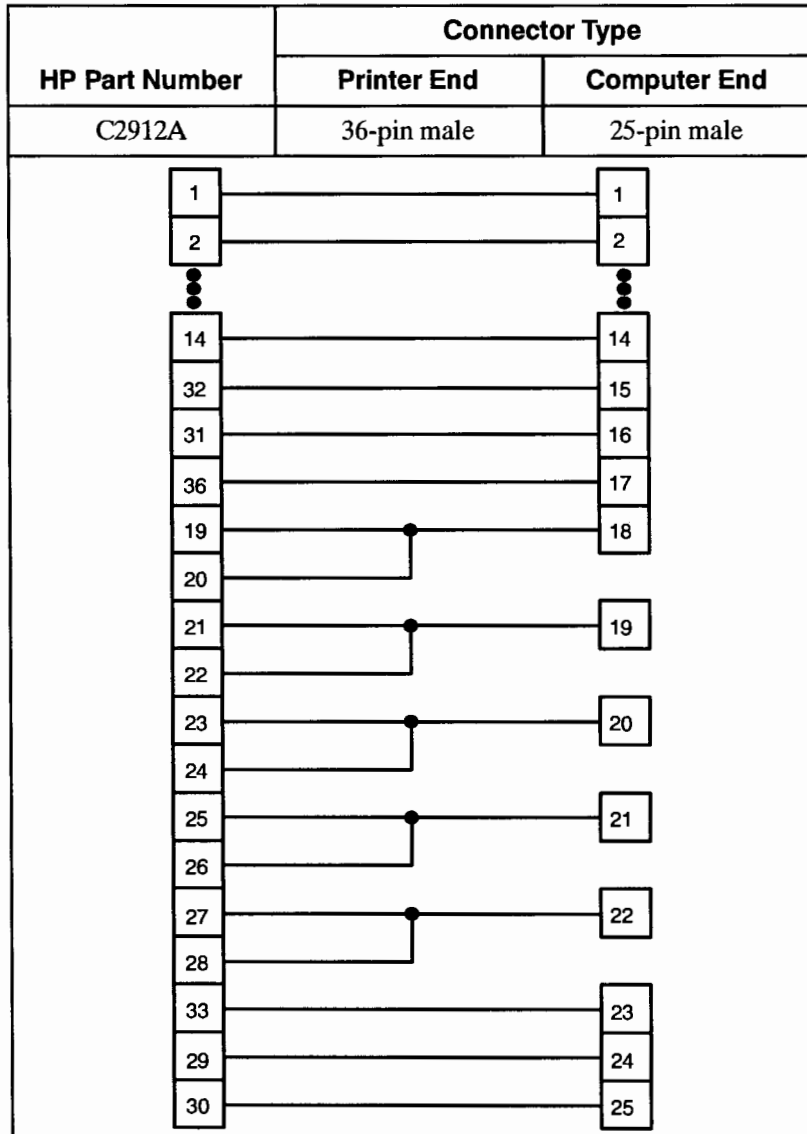

Technical information
Cable schematics

| HP Part Number | Connector Type | |
|----------------|----------------|---------------|
| | Printer End | Computer End |
| 13242D | 36-pin male | 25-pin female |
| 13 | ————— | 1 |
| 12 | ————— | 2 |
| 11 | ————— | 3 |
| 10 | ————— | 4 |
| 9 | ————— | 5 |
| 8 | ————— | 6 |
| 7 | ————— | 7 |
| 6 | ————— | 8 |
| 5 | ————— | 9 |
| 4 | ————— | 10 |
| 3 | ————— | 11 |
| 2 | ————— | 12 |
| 1 | ————— | 13 |
| 30 | ————— | 14 |
| 29 | ————— | 15 |
| 27 | ————— | 16 |
| 25 | ————— | 17 |
| 23 | ————— | 18 |
| 21 | ————— | 19 |
| 19 | ————— | 20 |



RS-422 cable schematics

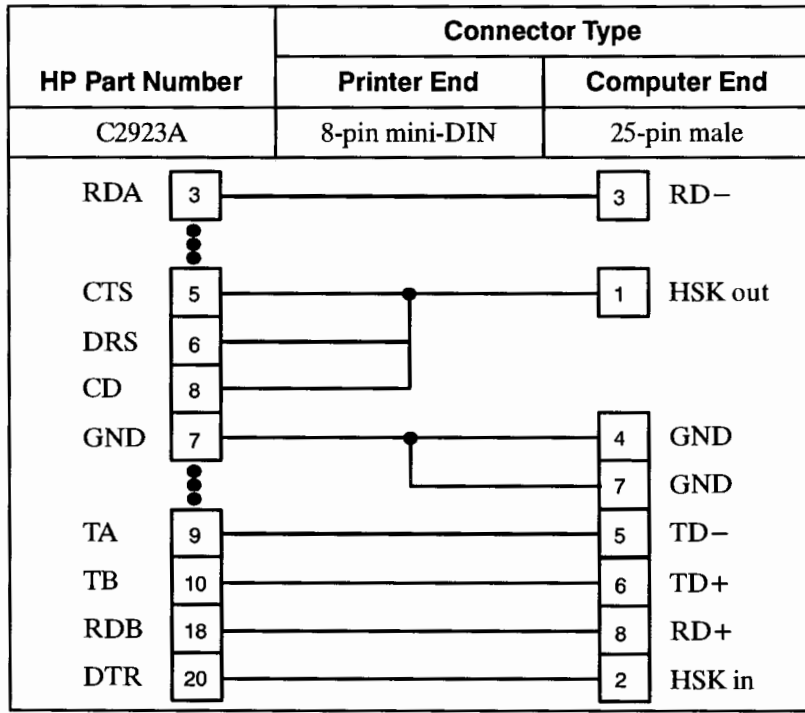

Pin-outs of the printer's rear-panel 8-pin mini-DIN connector are shown below.

| Pin Number | Signal |
|------------|------------------------------|
| 1 | Handshake out (HSK out) |
| 2 | Handshake in (HSK in) |
| 3 | Receive data negative (RD-) |
| 4 | Ground |
| 5 | Transmit Data Negative (TD-) |
| 6 | Transmit Data Positive (TD+) |
| 7 | Ground |
| 8 | Receive Data Positive (RD+) |

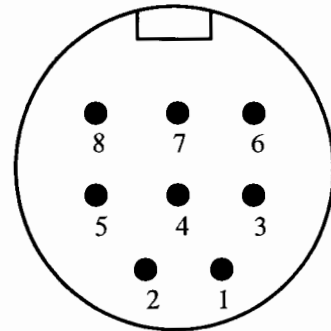

HP PaintJet XL300 command set

The *PCL 5 Printer Language Technical Reference Manual and PCL Comparison Guide* contains complete explanations of the Hewlett-Packard Printer Control Language instructions. This manual package is a valuable tool for writing your own PCL programs.

The *HP-GL/2 Reference Guide* contains complete explanations of the Hewlett-Packard Graphics Language. The companion document, the *HP-GL/2 Comparison Guide*, covers extensions to the basic instruction set and product-specific details.

Job control

| Command | Code | Range |
|--------------------------|---------------|-------------------|
| AppleTalk Configuration | Esc&b#W[data] | 0–32767 |
| Mechanical Print Quality | Esc*o#Q | –1,0,1 |
| Negative Motion | Esc&a#N | 0,1 |
| Number of Copies | Esc&l#X | 1–99 |
| Presentation Mode | Esc*r#F | 0,3 |
| Registration (Left) | Esc&l#U | (–32767)–(+32767) |
| Registration (Top) | Esc&l#Z | (–32767)–(+32767) |
| Reset | EscE | ~ |



Page control

| Command | Code | Range |
|-----------------------------|---------|----------------------------------|
| End-of-Line Wrap | Esc&s#C | 0–1 |
| Line Spacing | Esc&l#D | 0–Page Length |
| Line Termination | Esc&k#G | 0–3 |
| Margin (Left) | Esc&a#L | 0–Right Margin |
| Margin (Right) | Esc&a#M | L Margin to R logical page bound |
| Margin (Top) | Esc&l#E | 0–Page Length |
| Media Source | Esc&l#H | 0–2 |
| Media Type | Esc&l#M | 0–4 |
| Orientation | Esc&l#O | 0–3 |
| Page Length | Esc&l#P | # of lines |
| Paper Size | Esc&l#A | 2,3,6,26,27,46 |
| Perforation Skip Mode | Esc&l#L | 0–1 |
| Text Length | Esc&l#F | 0–(Page Length Top Margin) |
| Vertical Motion Index (VMI) | Esc&l#C | 0–Page Length |



Command set

Status

| Command | Code | Range |
|-------------------------------|-------------|--------------|
| Display Functions Mode Off | EscZ | ~ |
| Display Functions Mode On | EscY | ~ |
| Flush All Pages | Esc&r#F | 0-1 |
| Free Memory Space | Esc*s#M | 1 |
| Self-test | Escz | ~ |
| Transparent Print Mode | Esc&p#X | 0-32767 |



Language switching

| Command | Code | Range |
|--|---|---------|
| Comment (PJL) | @PJL COMMENT <comment text> | |
| Enter Language (PJL) | @PJL ENTER LANGUAGE = PCL @PJL ENTER LANGUAGE = POSTSCRIPT @PJL ENTER LANGUAGE = HPGL2 | |
| Enter HP-GL/2 mode | Esc%#B | -1,0-2 |
| Enter PCL mode | Esc%#A | 0,1 |
| Exit Language/Start PJL | Esc%#X | -12345 |
| Picture Frame Anchor Point | Esc*c#T | 0 |
| Picture Frame Horizontal Size (Decipoint) | Esc*c#X | 0-32767 |
| Picture Frame Vertical Size (Decipoints) | Esc*c#Y | 0-32767 |
| Plot Horizontal Size | Esc*c#K | 0-32767 |
| Plot Vertical Size | Esc*c#L | 0-32767 |



Control codes

| Command | Code | Range |
|-----------------|------|-------|
| Back Space | BS | ~ |
| Carriage Return | CR | ~ |
| Escape | ESC | ~ |
| Formfeed | FF | ~ |
| Horizontal Tab | HT | ~ |
| Line Feed | LF | ~ |
| Null | NUL | ~ |

Macros

| Command | Code | Range |
|---------------|---------|---------|
| Macro Control | Esc&f#X | 0-10 |
| Macro ID | Esc&f#Y | 0-32767 |



CAP movement

| Command | Code | Range |
|----------------------------------|---------|---------------------|
| Clear Margins | Esc9 | ~ |
| Horizontal Motion Index (HMI) | Esc&k#H | 0-32767 |
| Move CAP Horizontal (Columns) | Esc&a#C | (-32767) - (+32767) |
| Move CAP Horizontal (Decipoints) | Esc&a#H | (-32767) - (+32767) |
| Move CAP Horizontal (Dots) | Esc*p#X | (-32767) - (+32767) |
| Move CAP Vertical (Rows) | Esc&a#R | (-32767) - (+32767) |
| Move CAP Vertical (Decipoints) | Esc&a#V | (-32767) - (+32767) |
| Move CAP Vertical (Dots) | Esc*p#Y | (-32767) - (+32767) |
| Print Direction | Esc&a#P | 0, 90, 180, 270 |
| Push/Pop CAP | Esc&f#S | 0-1 |
| Space | SP | ~ |



Command set

Fonts

| Command | Code | Range |
|--------------------------------------|---------------|---------------------------------|
| Character ID | Esc*c#E | 0–32767 |
| Character Set | Esc(f#W[data] | 0–32767 |
| Character Set Control | Esc*c#S | 0–5 |
| Character Set ID | Esc*c#R | 0–32767 |
| Designate Download Font as Primary | Esc(#X | 0–32767 |
| Designate Download Font as Secondary | Esc)#X | 0–32767 |
| Download Character Descriptor | Esc(s#W | 0–32767 |
| Download Font Descriptor | Esc)s#W | 0–32767 |
| Font Control | Esc*c#F | 0–6 |
| Font ID | Esc*c#D | 0–32767 |
| Primary Font Character Set | Esc(ID | (see page T-9) |
| Primary Font Designation | Esc(#@ | 0–3 |
| Primary Font Height | Esc(s#V | > 0 (valid to 2 decimal places) |
| Primary Font Pitch | Esc(s#H | > 0 (valid to 2 decimal places) |
| Primary Font Spacing | Esc(s#P | 0,1 |



Fonts, continued

| Command | Code | Range |
|------------------------------|---------|---------------------------------|
| Primary Font Stroke Weight | Esc(s#B | -7 to 7 |
| Primary Font Style | Esc(s#S | 0-32767 |
| Primary Font Typeface | Esc(s#T | 0-32767 |
| Secondary Font Character Set | Esc)ID | (see page T-9) |
| Secondary Font Designation | Esc)#@ | 0-3 |
| Secondary Font Height | Esc)s#V | > 0 (valid to 2 decimal places) |
| Secondary Font Pitch | Esc)s#H | > 0 (valid to 2 decimal places) |
| Secondary Font Spacing | Esc)s#P | 0,1 |
| Secondary Font Stroke Weight | Esc)s#B | -7 to 7 |
| Secondary Font Style | Esc)s#S | 0-32767 |
| Secondary Font Typeface | Esc)s#T | 0-32767 |
| Shift In | SI | ~ |
| Shift Out | SO | ~ |
| Underline Mode Off | Esc&d@ | ~ |
| Underline Mode On | Esc&d#D | 0,3 |



Command set

Raster color

| Command | Code | Range |
|--------------------------|---------------|-----------------------|
| Color Component (First) | Esc*v#A | 0–32767 |
| Color Component (Second) | Esc*v#B | 0–32767 |
| Color Component (Third) | Esc*v#C | 0–32767 |
| Color Index | Esc*v#I | 0–(2 # bits/index –1) |
| Configure Image Data | Esc*v#W | 6,18 |
| Download Dither Matrix | Esc*m#W[data] | 6–32767 |
| Gamma Number | Esc*t#I | 0–32767 |
| Number of Planes per Row | Esc*r#U | –3,1,3 |
| Push/Pop Palette | Esc&p#P | 0–1 |
| Render Algorithm | Esc*t#J | 0–10 |
| Y Offset | Esc*b#Y | 0–Logical Page Bound |



Raster graphics

| Command | Code | Range |
|-------------------------------|---------|----------------|
| Compression Method | Esc*b#M | 0-3,5 |
| End Raster Graphics | Esc*r#C | ~ |
| Graphics Resolution | Esc*t#R | 75,100,150,300 |
| Raster Height (Destination) | Esc*t#V | 0-32767 |
| Raster Height (Source) | Esc*r#T | 0-32767 |
| Raster Width (Destination) | Esc*t#H | 0-32767 |
| Raster Width (Source) | Esc*r#S | 0-32767 |
| Scale Algorithm | Esc*t#K | 0-1 |
| Start Raster Graphics | Esc*r#A | 0-3 |
| Transfer Raster Data by Plane | Esc*b#V | 0-32767 |
| Transfer Raster Data by Row | Esc*b#W | 0-32767 |



Print model imaging

| Command | Code | Range |
|---|---------------|---------------------------------|
| Download Pattern | Esc*c#W[data] | 0-(2 ³¹ -1) |
| Fill Rectangle | Esc*c#P | 0-5 |
| Foreground Color | Esc*v#S | 0-(2 ^{#bits/index} -1) |
| Logical Op | Esc*l#O | 0-255 |
| Pattern Control | Esc*c#Q | 0,1,2,4,5 |
| Pattern ID | Esc*c#G | 0-32767 |
| Pattern Reference Point | Esc*p#R | 0-1 |
| Pattern Type | Esc*v#T | 0-4 |
| Rectangle Size, Horizontal (Decipoints) | Esc*c#H | 0-32767 |
| Rectangle Size, Horizontal (Dots) | Esc*c#A | 0-32767 |
| Rectangle Size, Vertical (Decipoints) | Esc*c#V | 0-32767 |
| Rectangle Size, Vertical (Dots) | Esc*c#B | 0-32767 |
| Transparency Mode (Pattern) | Esc*v#O | 0-1 |
| Transparency Mode (Source) | Esc*v#N | 0-1 |



HP-GL/2 vector group

| Command | Mnemonic | Parameters* |
|-----------------------------|----------|--|
| Arc Absolute | AA | x_center, y_center, sweep_angle [,chord_angle]; |
| Arc Relative | AR | x_increment, y_increment, sweep_angle [,chord_angle]; |
| Absolute Arc Three Point | AT | x_inter, y_inter, x_end, y_end [,chord_angle]; |
| Circle | CI | radius [,chord_angle]; |
| Plot Absolute | PA | [x, y...[,x, y]]; |
| Plot Relative | PR | [x, y...[,x, y]]; |
| Pen Down | PD | [x, y...[,x, y]]; |
| Pen Up | PU | [x, y...[,x, y]]; |
| Relative Arc Three Point | RT | x_incr_inter, y_incr_inter, x_incr_end, y_incr_end [,chord_angle]; |
| Polyline Encoded | PE | [flag[val] coord_pair...[flag[val] lcoord_pair]]; |
| Bezier Relative | BR | x1_control_pt_increment, y1_control_pt_increment, x2_control_pt_increment, y2_control_pt_increment, x3_control_pt_increment, y3_control_pt_increment, [,params]; |
| Bezier Absolute | BZ | x1_control_pt, y1_control_pt, x2_control_pt, y2_control_pt, x3_control_pt, y3_control_pt, [,params]; |

* Parameters in brackets are optional.



Command set

HP-GL/2 polygon group

| Command | Mnemonic | Parameters* |
|-------------------------|----------|---|
| Fill Rectangle Absolute | RA | x_coordinate, y_coordinate; |
| Fill Rectangle Relative | RR | x_increment, y_increment; |
| Edge Rectangle Absolute | EA | x_coordinate, y_coordinate; |
| Edge Rectangle Relative | ER | x_increment, y_increment; |
| Fill Wedge | WG | radius, start_angle, sweep_angle [,chord_angle]; |
| Edge Wedge | EW | radius, start_angle, sweep_angle [,chord_angle]; |
| Polygon Mode | PM | polygon_definition; |
| Fill Polygon | FP | {fill method} |
| Edge Polygon | EP | |

* Parameters in brackets are optional.

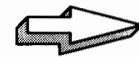

HP-GL/2 character group

| Command | Mnemonic | Parameters* |
|---------------------------|----------|---------------------------------|
| Select Standard Font | SS | |
| Select Alternate Font | SA | |
| Absolute Direction | DI | [run, rise]; |
| Relative Direction | DR | [run, rise]; |
| Absolute Character Size | SI | [width, height]; |
| Relative Character Size | SR | [width, height]; |
| Character Slant | SL | [tangent_of_angle]; |
| Extra Space | ES | [width [,height]] |
| Standard Font Definition | SD | [kind, value...[,kind, value]]; |
| Alternate Font Definition | AD | [kind, value...[,kind, value]]; |
| Character Fill Mode | CF | [fill_mode [,edge_pen]]; |
| Label Origin | LO | [position]; |
| Label | LB | [char ... [char]] lbterm |
| Define Label Terminator | DT | [lbterm [,mode]]; |
| Character Plot | CP | [spaces, lines]; |
| Transparent Data | TD | [mode]; |
| Define Variable Text Path | DV | [path [,line]]; |

* Parameters in brackets are optional.

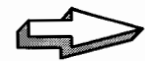

HP-GL/2 line and fill attributes group

| Command | Mnemonic | Parameters* |
|--------------------------|----------|---|
| Line Type | LT | [line_type [,pattern_length [,mode]]]; |
| Line Attributes | LA | [kind, value...[,kind, value]]; |
| Pen Width | PW | [width [,pen]]; |
| Pen Width Unit Selection | WU | [type]; |
| Select Pen | SP | [pen]; |
| Symbol Mode | SM | [char]; |
| Fill Type | FT | [fill_type [,option1 [,option2]]]; |
| Anchor Corner | AC | [x_coordinate, y_coordinate]; |
| Raster Fill Definition | RF | [index [,width, height, pen_nbr,...,pen_nbr]]; |
| User Defined Line Type | UL | [index [,gap1,...,gapn]]; |

* Parameters in brackets are optional.



HP-GL/2 configuration and status group

| Command | Mnemonic | Parameters* |
|--------------------------|----------|--|
| Scale | SC | [x1, x2, y1, y2 [,type[,left, bottom]]]; or [x1, xfactor, y1, yfactor,2]; |
| Input Window | IW | [xLL, yLL, xUR, yUR]; |
| Input P1 and P2 | IP | [p1x, p1y [,p2x, p2y]]; |
| Input Relative P1 and P2 | IR | [p1x, p1y [,p2x, p2y]]; |
| Default Values | DF | |
| Initialize | IN | [n]; |
| Rotate Coordinate System | RO | [angle]; |
| Advance Full Page | PG | [n]; |
| Replot | RP | [n]; |

* Parameters in brackets are optional.



HP-GL/2 technical graphics extension

| Command | Mnemonic | Parameters* |
|------------------------|-----------------|--|
| Begin Plot | BP | [kind, value...[,kind, value]]; |
| Chord Tolerance Mode | CT | [mode]; |
| Download Character | DL | [charnum [;[,up], x, y...[,up],x .y]]; |
| **Enable Cutter | EC | [n]; |
| Frame Advance | FR | |
| Merge Control | MC | [mode]; |
| **Message | MG | [messagestring]; |
| Media Type | MT | [type]; |
| **Not Ready | NR | [timeout]; |
| Output Error | OE | |
| Output Hardclip Limits | OH | |
| Output Identification | OI | |
| Output P1 and P2 | OP | |
| Output Status | OS | |
| Plot Size | PS | [length [, width]]; |
| Quality Level | QL | [quality level] |
| **Sort | ST | [switches]; |
| **Velocity Select | VS | [velocity [, pen]]; |

* Parameters in brackets are optional.

** These commands are No Operation (NOP) instructions on the PaintJet XL300 and are ignored.



HP-GL/2 Palette extensions

| Command | Mnemonic | Parameters* |
|----------------------|----------|---|
| Set Color Range | CR | [b_ref_red, w_ref_red, b_ref_grn, w_ref_grn, b_ref_blue, w_ref_blue]; |
| Number of Pens | NP | [n]; n > 1 |
| Pen Color Assignment | PC | [pen [,red, green, blue]]; |
| Screened Vectors | SV | [screen_type [,option1 [,option2]]]; |
| Transparency Mode | TM | [n]; n = 0 or 1 |

HP-GL/2 Dual context extension

| Command | Mnemonic | Parameters* |
|-----------------------------------|----------|-----------------|
| Enter PCL Mode | Esc%#A | 0 to 1 |
| Reset | EscE | |
| Primary Font Selection by ID | FI | font_ID; |
| Secondary Font Selection by ID | FN | font_ID; |
| Scalable or Bitmap Fonts | SB | [n]; n = 0 or 1 |

* Parameters in brackets are optional.



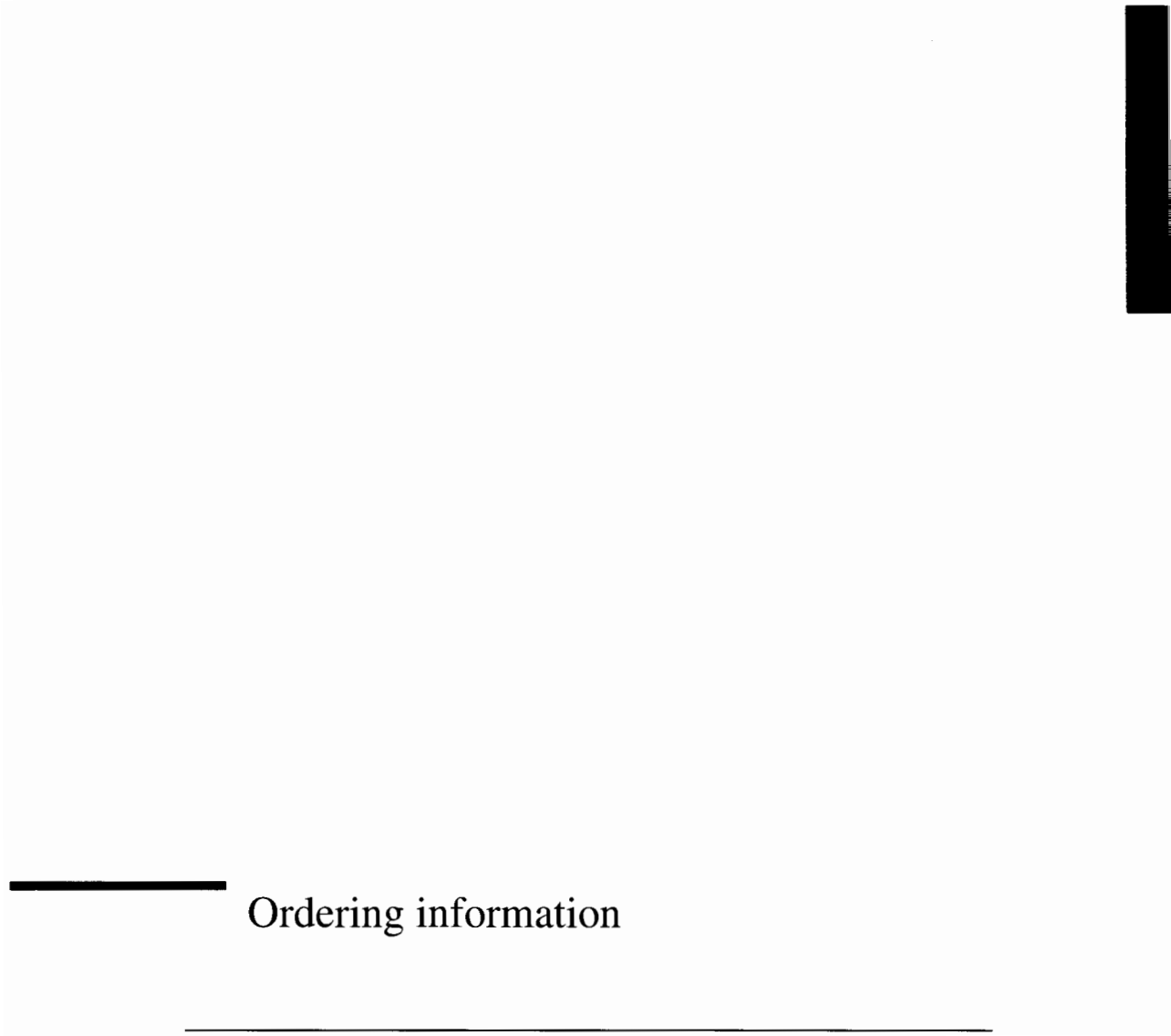

Ordering information

How to order HP PaintJet XL300 accessories and supplies

In the U.S. you may order printer accessories and supplies by calling HP's North American Distribution Operation (NADO) 1-800-538-8787 to get the name of your local authorized HP dealer.

Outside the U.S. call your local authorized HP dealer.



Printer Accessories

| Item | HP Part Number |
|--|----------------|
| Print cartridge, black | 51639A |
| Print cartridge, cyan | 51639C |
| Print cartridge, magenta | 51639M |
| Print cartridge, yellow | 51639Y |
| | |
| CX JetSeries CutSheet Paper, A (200 sheets, 8.5 by 11 in.) | 51630Y |
| CX JetSeries CutSheet Paper, A4 (200 sheets, 210 by 297 mm) | 51630Z |
| CX JetSeries CutSheet Paper, B (200 sheets, 11 by 17 in.) | 51631A |
| CX JetSeries CutSheet Paper, A3 (200 sheets, 297 by 420 mm) | 51631B |
| LX JetSeries Glossy Paper, A (50 sheets, 8.5 by 11 in.) | 51636H |
| LX JetSeries Glossy Paper, A4 (50 sheets, 210 by 297 mm) | 51636J |
| LX JetSeries Transparency Film, A (50 sheets, 8.5 by 11 in.) | 51636F |
| LX JetSeries Transparency Film, A4 (50 sheets, 210 by 297 mm) | 51636G |
| | |
| Control-panel overlay (English) | C1645-60030 |
| Control-panel overlay (Swedish) | C1645-60035 |
| Control-panel overlay (German) | C1645-60032 |
| Control-panel overlay (French) | C1645-60031 |
| Control-panel overlay (Spanish) | C1645-60034 |
| Control-panel overlay (Italian) | C1645-60036 |
| Control-panel overlay (Japanese) | C1645-60033 |
| Control-panel overlay (Dutch) | C1645-60072 |



Printer Accessories, continued

| Item | HP Part Number |
|---|----------------|
| HP-GL/2 Reference Guide | 5959-9733 |
| HP-GL/2 Comparison Guide | 5959-9734 |
| PCL 5 Printer Language Technical Reference Manual and PCL 5 Comparison Guide (PCL document package) | 33481-90969 |
| HP PaintJet XL300 Service Manual | C1645-90000 |
| Dust Cover | 92259U |
| Media Trays | |
| A/A4/Legal-size | C1648A |
| B-size | C1653A |
| A3-size | C1654A |
| B4-size (Japan) | C1655A |



Printer Accessories, Continued

| Item | HP Part Number |
|--|----------------|
| Parallel shielded cable (for use with HP Touchscreen) | 13242D (2 m) |
| Parallel shielded cable (for use with Commodore Amiga 500/2000, HP Vectra†, IBM PC/XT/AT, and AT&T PC 6300) | C2912A |
| Serial RS-422 cable (HP Vectra or other IBM PC/AT compatible with HP 24541A/B dual serial interface card using 25-pin connector) | C2923A |
| Serial RS-422 cable (Apple System Peripheral-8) | 92215S |
| LocalTalk cable (Apple networks) | 92215N |
| HP Apollo 9000 Series 400 and Series 700 workstations | C2912A |
| Workstations with parallel interface | C2912A |
| Workstations with RS-422 and no parallel interface | C2923A |



† Requires HP 24540A Serial/Parallel Interface Card.



Accessories**Printer Accessories, Continued**

| Item | HP Part Number |
|--|----------------|
| PostScript Upgrade | C1651A |
| Memory Expansion board (blank) | C1650A |
| Memory Expansion board (4Mbyte) | C1652A |
| 1 Mbyte SIMM | C2063A |
| 4 Mbyte SIMM | C2065A |
| 8 Mbyte SIMM | C2066A |
| HP JetDirect Card for Novell NetWare | |
| Ethernet | C2059A |
| Token Ring | C2059C |
| HP JetDirect Card for LAN Manager (3Com 3+OPEN, IBM LAN Server, Microsoft LAN Manager) | |
| Ethernet | C2059B |
| Token Ring | C2059D |
| HP JetDirect Card for AppleTalk | |
| EtherTalk | C2059E |
| HP JetDirect Card for Unix | |
| TCP/IP Ethernet | C2059T |
| HP JetDirect Card for HP-IB | C1642A |
| Ethernet 10Base-T adapter kit (includes EtherTwist transceiver 28685B) | C1647A |



Printer Accessories, Continued

| Item | HP Part Number |
|--|----------------|
| HP PaintJet XL300 User's Guide | |
| English | C1645-90061 |
| Swedish | C1645-90063 |
| German | C1645-90064 |
| French | C1645-90065 |
| Spanish | C1645-90066 |
| Italian | C1645-90067 |
| Japanese | C1645-90068 |
| Dutch | C1645-90069 |
| HP PaintJet XL300 Getting Started | |
| English | C1645-90081 |
| Swedish | C1645-90083 |
| German | C1645-90084 |
| French | C1645-90085 |
| Spanish | C1645-90086 |
| Italian | C1645-90087 |
| Japanese | C1645-90088 |
| Dutch | C1645-90089 |
| HP PaintJet XL300 PostScript Installation Guide | |
| English | C1656-90001 |
| Swedish | C1656-90003 |
| German | C1656-90004 |
| French | C1656-90005 |
| Spanish | C1656-90006 |
| Italian | C1656-90007 |
| Japanese | C1656-90008 |
| Dutch | C1656-90009 |



Additional documentation

The *HP-GL/2 Reference Guide* contains complete explanations of the Hewlett-Packard Graphics Language. The companion document, the *HP-GL/2 Comparison Guide*, covers extensions to the basic instruction set and product-specific details.

The *PCL 5 Printer Language Technical Reference Manual*, the *HP PaintJet XL300 PCL 5C Color Printer Language Technical Reference Manual*, and the *PCL Comparison Guide* contain complete explanations of the Hewlett-Packard Printer Control Language instructions. This manual package is a valuable tool for writing your own PCL programs.

Order any of the documentation listed below if you want information pertaining to typefaces.

| | |
|--|-----------|
| The Long and Short of HP Scalable Type | 5091-1327 |
| The Unabridged HP MasterType Library Encyclopedia | 5091-0580 |
| MasterType Library Selection Guide | 5091-3491 |



Using HP FIRST

Hewlett-Packard's Fax Information Retrieval Support Technology (HP FIRST) provides access to frequently requested information 24 hours a day, 7 days a week. Both dealers and customers can access HP FIRST from a touch-tone, 9600-baud, Group 3 Fax machine. There is no charge for using HP FIRST.

Follow these steps to receive information via Fax from HP FIRST:

- 1 Dial **(208) 344-4809** from the Fax machine's handset.
- 2 When HP FIRST prompts you, select the product category or topic for which you wish to obtain information (for example, PC Peripherals).
- 3 If you already know the four-digit ID number of the document you would like to receive, press [1]. If you would like to receive a listing of available documents and their four-digit ID numbers, press [2].
- 4 HP FIRST will prompt you to enter the four-digit ID number for each document.
- 5 When HP FIRST prompts you, press the [Start/Copy] or [Receive] button on your Fax machine, then hang up the handset.
- 6 You will then receive the requested support literature and information. The time required to receive the information will vary depending on the length and complexity of the documents requested.



Glossary

application Short for application program, a software package that does a specific task, such as word processing, text formatting, or graphics.

baud rate The data transmission rate between a computer and a peripheral. The computer and the peripheral must be configured for the same baud rate for information to transfer correctly.

bitmapped (1) A set of bits that represents the graphic image of an original document in memory. (2) A set of bits that represents the positions and states of a corresponding set of items, such as pixels. In QuickDraw, a pointer to a bit image, the row width of that image, and its boundary rectangle. Used by the Macintosh to construct graphic images and typefaces.

bitmapped font A font whose characters are formed by patterns of tiny dots. Bitmapped fonts are always a specific point size.

buffer A segment of the computer's or printer's memory where information is held until it can be processed.

cable An insulated bundle of wires with connectors on the ends. Examples are serial cables and LocalTalk cables.

Chooser A desk accessory that lets you configure your computer system to print on any printer for which there is a **printer resource** in the System folder on the current startup disk. If your Macintosh computer is part of an AppleTalk network system, use the Chooser to connect and disconnect from the network and to choose among devices connected to the network.

clear To clear out any air bubbles in the print cartridge that are obstructing ink flow through the nozzle plate.

click To position the pointer on an **object** or **icon**, then press and quickly release the mouse button.



connection box A small box at one end of a LocalTalk connector. Cables plug into the box, allowing network signals to flow through it.

connector A plug, socket, jack, or port. See also **LocalTalk connector**.

default A value or condition that is assumed when the printer is powered on. Also, a preset selection in a dialog box that is automatically used by the computer if you do not make a different selection.

desktop Your working environment for the Macintosh computer, for Windows in a PC, or workstation windows.

device name The name used in pathnames to refer to a particular device without regard to the files associated with the device.

dialog box A box containing a message requesting more information from you. The message may be a warning that you are asking the computer to do something that it can't do, or that you are about to destroy some information. In these cases, the message is often accompanied by a beep.

disabled Describes a menu item or menu that cannot be chosen; the menu item or menu title appears dimmed. A disabled item in a dialog or alert box has no effect when clicked.

double-click To position the pointer where you want the next action to take place, and then press and release the mouse button twice in quick succession without moving the mouse. Double-clicking is a quick way of doing common tasks such as opening documents.

downloading The process of transmitting font data from computer to printer memory.





dpi Dots per inch. DPI describes the number of ink dots printed within one horizontal inch, also known as the resolution of bitmapped images on the printer. The HP PaintJet XL300 prints images at 300 dpi.

driver A computer file that controls the operations of a printer device. It requires font metrics to use fonts. (Usually “printer driver”).

eject (1) To remove a disk from a disk drive. (2) To move paper out of the printer.

file A collection of related information stored on a disk such as document, a folder, a system file, a resource, or an application.

font A complete set of characters in one design and style. In traditional typographical usage, font may be restricted to a particular size or may comprise several sizes and styles of the typeface design.

handshake A method of communication between a computer and printer about the availability of buffer space (memory) in the printer. A handshake ensures correct and complete data transfer.

internal typeface A typeface stored in the printer’s internal read-only memory. An internal typeface is printed when the printer is in text mode (that is, not printing graphics) and receives printable ASCII characters. See also **printer font**, **screen font**.

LocalTalk cable system A system of cables, cable extenders, and connector boxes that connect computers and network devices as part of the AppleTalk network system.

LocalTalk connector A piece of equipment consisting of a connection box, a short cable, and a machine-specific connector, that enables an Apple computer to be part of an Apple Talk network system. Also called a **LocalTalk connector box**.



network A collection of interconnected, individually controlled computers, together with the hardware and software used to connect them. A network allows users to share data and peripheral devices such as printers and storage media, to exchange electronic mail, and so on.

network connection A combination of hardware and software that lets you set up the unique interconnections of various networking systems.

off-line Not currently connected to or under the control of the computer. Used to refer to equipment such as printers and disk drives, information storage media such as disks, and the information they contain. Compare **on-line**.

on-line Currently connected to and under the control of the computer. Used to refer to equipment such as printers and disk drives, information storage media such as disks, and the information they contain. Compare **off-line**.

parallel interface An interface type in which a separate line is used for each data bit in a byte or word, and all bits are transferred simultaneously.

pixel Short for *picture element*; the smallest dot you can draw on the screen or printer.

point A unit of measurement for type. One point is $1/72$ of an inch. Character height is given in points. For example, 12 point type is $1/6$ of an inch high.

port A socket on the back panel of a computer where you plug in a cable for connection to a network or a peripheral device.

print cartridge The casing that holds the ink used in printing. The PaintJet XL300 has four cartridges: one each containing black, cyan, magenta, and yellow ink.





resolution A measure of image (display or print) sharpness expressed as number of dots per inch (**dpi**). The higher the value, the finer the detail of the image.

sans serif Without serifs (see serif); A sans-serif M looks like this: **M**.

scalable typeface Scalable typefaces are character outlines described by a mathematical formula. This information is used to shrink or enlarge the typeface to virtually any point size.

scaling The process of shrinking or enlarging a typeface to create fonts of different point sizes.

serial interface An interface in which information is transmitted sequentially, one bit at a time, over a single wire or channel.

serif Serifs are fine strokes that finish off the main strokes of a letter — like the little “feet” on the bottom of the vertical strokes in the letter **M**.

startup disk The disk that contains the System file that the Macintosh computer needs to get started. A startup disk must have a least a Finder and a System file. The HP PaintJet XL300 software must be installed on a startup disk. Sometimes called a *boot disk*.

type director HP’s font management program; software which allows you to scale HP’s disk-based scalable typefaces for HP LaserJet and PaintJet printers.

WYSIWYG What-You-See-Is-What-You-Get. How text and graphics look on your computer screen is how they’ll look on your printed document.



Index

A

accessories, O-3
adding memory, 1-4
air bubbles, 7-4
autosensing, 1-6

B

baud rate, 3-18
before using software, 4-3
bitmapped fonts, T-9
Busy light, 3-11

C

cable schematics, T-15
cables, ordering, O-5, O-6
cartridge, clearing, 7-4, 7-19
cartridges, ink life, 2-11
clearing, 7-4, 7-19
color
 best practices, 6-7
 importing, 6-6
 matching screen to print, 6-5
 software support, 6-4
colored text, 6-8
command set, T-18
configuring software, 4-3

conformance to safety and EMC
 specifications, T-4
control panel, 3-3
control-panel overlay, ordering,
 O-7
customer assist line, 7-23
CX JetSeries CutSheet Paper, 2-3

D

Declaration of conformity, to safety
 and EMC specifications, T-4
default typefaces, 5-3
defaults, typeface cartridge, 5-11
deleting disk-based typefaces, 5-8
demo printout, 3-9
disk-based typefaces, 5-5, 5-9
DOC statement (Canada), T-3
documentation
 additional, O-8
 ordering, O-3
downloadable typefaces, 5-5
downloading typefaces
 bit-mapped and scalable, 5-6
 using FontLoad, 5-7
 using MS-DOS, 5-6
 using Type Director, 5-7
dust, 7-4



E

environmental conditions, 7-3
escape sequence tables, T-18

F

fax support documentation, O-9
FCC statement (U.S.A.), T-2
fingerprints, 2-4
font cartridges. *See* typeface
cartridges
font list, 3-10
font rotation, 5-4
FontLoad, 5-7
Form Feed button, 3-7

G

Geräuschemission, T-3
getting help, 7-23
getting printer drivers, 4-5
glossy paper, 2-8, 2-10

H

handshake, 3-18
help line, 7-23
help number, 7-24
HP FIRST, fax documentation, O-9
HP PaintJet XL300 driver, 4-5
HP Personal Peripheral Assist line,
7-23
HP-GL/2 command set, T-29
HP-GL/2, 3-19

I

incomplete printing, 1-4
initializing, 7-14
ink life, 2-11
installing memory, 8-3
installing options, 8-2
installing typeface cartridge, 8-7
interface, cables, O-5
interface cards, 1-5
ordering, O-5, O-6
internal symbol sets, T-10



J

jammed paper, 7-12

L

light indications, 7-15

lights all flashing, 7-17

loading media, manual, 2-3, 3-12

LX JetSeries Transparencies, 2-3

M

maintenance, 7-3

Manual light, 3-12

margins, 2-5

Material Safety Data Sheet, T-14

media

loading, 2-3

ordering, O-7

plain paper, 2-4

printable area, 2-5

sizes, 2-5, 3-24

types, 2-3

Media button, 3-9

media problems, 7-12

memory, 1-4

installation, 8-3

ordering, O-5, O-6

N

network problems, 7-20

networked printer, 1-8

not enough printer memory, 1-4

nothing prints, 7-16

O

On Line button, 3-6

options, installation, 8-2

ordering accessories, O-2

out of memory, 1-4

P

paper, 2-3

jam, 7-12

ordering, O-7

Paper/Print Cartridges light, 3-4,
3-13, 7-4, 7-12

PCL 5 reference manual, O-8

PostScript, 3-19

PostScript typefaces, 5-12

power cord options, T-12

presentations, 6-9

print cartridge, ordering, O-7

print cartridge problems, 7-4



P (continued)

- print cartridges, 7-19
- print margins, 2-5
- print quality, paper, 2-4
- printable area, 2-5
- printer
 - initializing, 7-14
 - operation problems, 7-14
 - shipping, 7-22
- printer control, 1-7
- printer drivers, 4-4
- printer features, 1-3
- printer language, 3-19
- Printing
 - consecutive pages, 3-12
 - incompletely, 7-7
 - transparencies, 2-8
- printing
 - glossy paper, 2-8
 - quality, problems, 7-19
- printing a file, 4-7
- problems
 - can't select printer, 7-18
 - dust/air bubbles, 7-4
 - Macintosh, 7-18
 - media, 7-12
 - network, 7-20
 - nothing prints, 7-14
 - print cartridge, 7-4
 - printer operation, 7-11
 - software, 7-21
 - troubleshooting table, 7-15

Q

- quality of print, problems, 7-19

R

- Ready button, 3-5
- rear-panel switches, 3-15
- regulatory notices, T-2
- returning printer, 7-22
- Reverse button, 3-8, 7-13, 7-17
- rotating fonts, 5-4

S

- scalable typefaces, T-9
- selecting a printer language, 3-19
- self test, 3-10, 7-7
- self test print out, 7-11
- setting a baud rate, 3-18
- setting handshake, 3-18
- setting margins with software, 4-8
- setting PostScript, 3-19
- shared printer, 1-8
- shipping the printer, 7-22
- SIMM installation, 8-3



S (continued)

software
 printing a file, 4-7
 problems with margins, 4-8
 using color, 6-4
 writing programs, 4-10

software problems
 Macintosh, 7-21
 Windows, 7-21

specifications, T-5

supplies, O-3

support documentation, fax, O-9

symbol sets
 establishing, 3-24
 PC8, 3-21, 3-24
 Roman8, 3-21, 3-24
 selecting, 3-21

T

technical information, T-1

Telecommunications General
 Approval (U.K.), T-3

Test Button, 3-10

transparencies, 2-8, 4-9

transparency, mode, 4-9

transparency film, 2-8, 2-10

tray cover, loading from, 2-3

troubleshooting, 7-2

troubleshooting table, 7-15

Type Director, 5-7

typeface cartridges, 5-10

typefaces
 deleting, 5-8
 downloadable, 5-5

V

VCCI-2, T-3





HP PaintJet XL300 Color Printer User's Guide

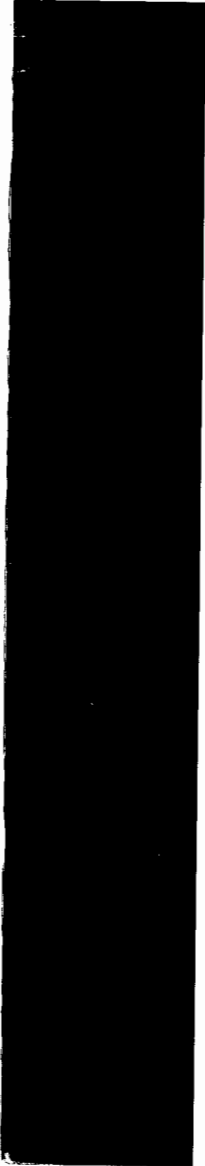

Manual Part Number: C1645-90061
Printed in U.S.A., December 1992