

# HEWLETT-PACKARD

## LaserJet Printer Family

# Technical Reference Manual

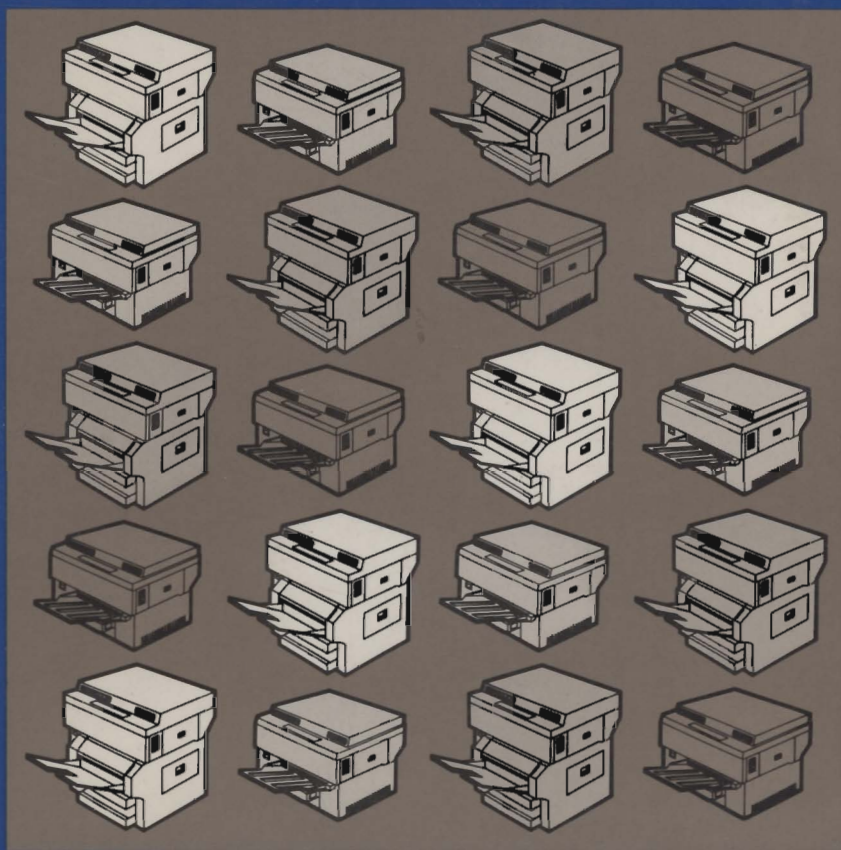

**HP Computer Museum**  
**[www.hpmuseum.net](http://www.hpmuseum.net)**

**For research and education purposes only.**

**LaserJet Printer Family**

**Technical**

**Reference Manual**



January 1986  
02686-90912



## NOTICE

The information contained in this document is subject to change without notice.

HEWLETT-PACKARD MAKES NO WARRANTY OF ANY KIND WITH REGARD TO THIS MATERIAL, INCLUDING, BUT NOT LIMITED TO, THE IMPLIED WARRANTIES OF MERCHANTABILITY AND FITNESS FOR A PARTICULAR PURPOSE. Hewlett-Packard shall not be liable for errors contained herein or for incidental or consequential damages in connection with the furnishing, performance, or use of this material.

This document contains proprietary information which is protected by copyright. All rights are reserved. No part of this document may be photocopied, reproduced, or translated to another program language without the prior written consent of Hewlett-Packard Company.

MS is a trademark of MicroSoft Corp.

IBM is a registered trademark of International Business Machines Corp.

---

### **Printing History**

New editions of this manual will incorporate all material since the previous edition. Update packages may be used between editions and contain replacement and additional pages to be merged into the manual by the user.

The manual printing date and part number indicate its current edition. The printing date changes when a new edition is printed. (Minor corrections and updates which are incorporated at reprint do not cause the date to change.)

First Edition - January 1986

---

# Table of Contents

---

---

---

---

---

## Chapter I. General Information

---

|  |      |
|--|------|
| Introduction . . . . .   | 1-1  |
| Program Compatibility. . . . .                                       | 1-2  |
| The LaserJet Printer vs. the LaserJet <sup>+</sup> Printer . . . . . | 1-3  |
| LaserJet 500 <sup>+</sup> Printer Features. . . . .                  | 1-5  |
| How to Use This Manual . . . . .                                     | 1-5  |
| How to Use Escape Sequences. . . . .                                 | 1-6  |
| Useful Information. . . . .  | 1-9  |
| Combining Escape Sequences. . . . .                                  | 1-10 |

---

## Chapter II. LaserJet Printer Family Features

---

|   |      |
|---|------|
| Introduction . . . . .                                  | 2-1  |
| Control Codes . . . . .                                 | 2-3  |
| Page Formatting. . . . .                                | 2-4  |
| The Default Page Format . . . . .                       | 2-6  |
| Specifying Page Length (Size of Paper). . . . .         | 2-7  |
| Setting the Top Margin. . . . .                         | 2-9  |
| Text Length Selection. . . . .                          | 2-10 |
| Vertical Line Spacing . . . . .                         | 2-11 |
| Horizontal Cursor Spacing. . . . .                      | 2-12 |
| Setting and Clearing Side Margins . . . . .             | 2-13 |
| Example: Page Formatting . . . . .                      | 2-14 |
| Cursor Positioning . . . . .                            | 2-15 |
| Horizontal Cursor Positioning (Using Columns) . . . . . | 2-15 |
| Vertical Cursor Positioning (Using Lines) . . . . .     | 2-16 |

|  |      |
|--|------|
| Horizontal Cursor Positioning (Using Decipoints) . . . . . | 2-17 |
| Vertical Cursor Positioning (Using Decipoints) . . . . .   | 2-18 |
| Selecting Character Fonts . . . . .                        | 2-19 |
| Character Font Orientation . . . . .                       | 2-23 |
| Default Font Characteristics & Resident Fonts . . . . .    | 2-24 |
| Symbol Set Selection . . . . .                             | 2-25 |
| Proportional vs. Fixed Spacing . . . . .                   | 2-27 |
| Font Pitch Selection . . . . .                             | 2-28 |
| Character Height (Point Size) Selection . . . . .          | 2-29 |
| Character Style (Italic/Upright) . . . . .                 | 2-30 |
| Stroke Weight . . . . .                                    | 2-31 |
| Typeface Selection . . . . .                               | 2-32 |
| Example: Selecting a Character Font . . . . .              | 2-33 |
| Switching Between Primary & Secondary Fonts . . . . .      | 2-34 |
| Raster Graphics . . . . .                                  | 2-35 |
| Raster Graphics Resolution . . . . .                       | 2-36 |
| Start Raster Graphics . . . . .                            | 2-38 |
| Transfer Raster Graphics . . . . .                         | 2-38 |
| End Raster Graphics . . . . .                              | 2-39 |
| Example: Raster Graphics . . . . .                         | 2-40 |
| Miscellaneous Features . . . . .                           | 2-42 |
| Display Functions . . . . .                                | 2-42 |
| Transparent Print Data . . . . .                           | 2-43 |
| Perforation Skip Mode . . . . .                            | 2-43 |
| Character Overstrike . . . . .                             | 2-44 |
| Automatic Underlining . . . . .                            | 2-44 |
| Half Line Feed . . . . .                                   | 2-45 |
| Line Termination . . . . .                                 | 2-45 |
| End-of-Line Wrap . . . . .                                 | 2-46 |
| Portrait/Landscape Orientation . . . . .                   | 2-46 |
| Select Number of Copies . . . . .                          | 2-47 |
| Paper Input Control . . . . .                              | 2-47 |
| Specialized Printer Control . . . . .                      | 2-48 |
| Reset . . . . .  | 2-48 |
| Self-Test . . . . .  | 2-51 |

---

## Chapter III. LaserJet<sup>+</sup>/LaserJet 500<sup>+</sup>

### Additional Printer Features

---

|                              |     |
|------------------------------|-----|
| Introduction . . . . .       | 3-1 |
| Memory Utilization . . . . . | 3-2 |

|  |      |
|--|------|
| Cursor Control (in Dots) . . . . .                     | 3-2  |
| Fonts . . . . .  | 3-4  |
| Font Management Escape Sequences . . . . .             | 3-5  |
| Assigning a Font ID to a Font Cartridge Font . . . . . | 3-20 |
| Downloading E P Fonts. . . . .                         | 3-21 |
| Downloading Character Fonts--General Method. . . . .   | 3-26 |
| Macros. . . . .  | 3-27 |
| Macro Escape Sequences . . . . .                       | 3-27 |
| Macro Example. . . . .                                 | 3-31 |
| Push/Pop Position. . . . .                             | 3-32 |
| Advanced Graphics. . . . .                             | 3-33 |
| Escape Sequences for Advanced Graphics. . . . .        | 3-34 |

---

## Chapter IV. LaserJet 500+

### Additional Printer Features

---

|  |      |
|--|------|
| Introduction . . . . .                               | 4-1  |
| Sheet Feeder Control. . . . .                        | 4-2  |
| Job Offset Control. . . . .                          | 4-4  |
| Paper Input Control. . . . .                         | 4-7  |
| Selecting Page Length. . . . .                       | 4-8  |
| Configuring Auto-Select Mode Power-On State. . . . . | 4-11 |

---

## Chapter V. Programming Hints

---

|   |      |
|---|------|
| Introduction . . . . .                            | 5-1  |
| Page Printing. . . . .                            | 5-2  |
| Page Formatting. . . . .                          | 5-3  |
| Font Selection . . . . .                          | 5-7  |
| Raster Graphics . . . . .                         | 5-8  |
| Automatic Underlining . . . . .                   | 5-9  |
| Multiple Copies . . . . .                         | 5-12 |
| LaserJet+/LaserJet 500+ Throughput. . . . .       | 5-12 |
| LaserJet+/LaserJet 500+ Font Management . . . . . | 5-13 |
| Selecting Downloaded Fonts. . . . .               | 5-14 |
| Sending Binary Data . . . . .                     | 5-15 |

---

**Appendix A. Escape Sequence Summary**

---

---

**Appendix B. ASCII Tables**

---

---

**Appendix C. Switching RS-232C/RS-422 Interfaces  
and Baud Rate**

---

---

**Appendix D. Interface Configuration and Cable  
Pin Assignments**

---

---

**Glossary**

---

---

**Index**

---



## Table of Figures

|  |      |
|--|------|
| Figure 2-1. Page Formatting Parameters . . . . .     | 2-5  |
| Figure 2-2. Default Page Format--Portrait . . . . .  | 2-6  |
| Figure 2-3. Default Page Format--Landscape . . . . . | 2-6  |
| Figure 2-4. Text Length and Bottom Margin . . . . .  | 2-10 |
| Figure 2-5. Portrait/Landscape Orientation . . . . . | 2-23 |
| Figure 3-1. Font Descriptor . . . . .                | 3-10 |
| Figure 3-2. Font Description Information . . . . .   | 3-11 |
| Figure 3-3. Character Descriptor . . . . .           | 3-16 |
| Figure 3-4. Character--Portrait Mode . . . . .       | 3-17 |
| Figure 3-5. Character--Landscape Mode . . . . .      | 3-18 |
| Figure 3-6. Gray Scale Patterns . . . . .            | 3-36 |
| Figure 3-7. HP-Defined Patterns . . . . .            | 3-37 |

## List of Tables

|  |      |
|--|------|
| Table 2-1. Control Codes . . . . .   | 2-3  |
| Table 2-2. Accessing Control Codes from<br>Keyboard & BASIC . . . . .                            | 2-4  |
| Table 2-3. Symbol Sets . . . . .   | 2-26 |
| Table 2-4. Typeface Value Numbers . . . . .  | 2-33 |
| Table 2-5. Maximum Raster Image Size . . . . .   | 2-37 |
| Table 2-6. Paper Input Control Values . . . . .  | 2-48 |
| Table 2-7. Default Values . . . . .  | 2-50 |
| Table 3-1. Font and Character Control . . . . .  | 3-6  |
| Table 3-2. Symbol Sets . . . . .   | 3-12 |
| Table 3-3. Typeface Values . . . . .   | 3-14 |
| Table 3-4. Macro Control Functions . . . . .   | 3-28 |
| Table 3-5. Current Environment Variables . . . . .   | 3-29 |
| Table 3-6A. Overlay Environment Variables . . . . .  | 3-30 |
| Table 3-6B. Overlay Default Variables . . . . .  | 3-30 |
| Table 4-1. Recommended Paper Tray Configuration . . . . .  | 4-3  |
| Table 4-2. Paper Input Control Values . . . . .  | 4-6  |
| Table 5-1. Addressable Areas . . . . .   | 5-3  |
| Table 5-2. Printable Areas . . . . .   | 5-4  |
| Table 5-3. Default Margins . . . . .   | 5-4  |
| Table C-1. <b>LaserJet<sup>+</sup>/LaserJet 500<sup>+</sup></b><br>SW1 Switch Settings . . . . . | C-7  |



---

# Chapter I

---

---

## GENERAL INFORMATION

---

### Introduction

The **LaserJet** printer family (**LaserJet**, **LaserJet<sup>+</sup>**, and **LaserJet 500<sup>+</sup>**) contains quick, quiet, reliable, high-resolution printers. This manual provides the necessary information for programming any or all of the printers in the **LaserJet** printer family.

All **LaserJet** family printers provide a core set of features—those features of the **LaserJet** printer, which are discussed in Chapter 2. The **LaserJet<sup>+</sup>** printer provides all of the features of the **LaserJet** printer and adds features such as increased memory, downloadable fonts, and macro capability. The **LaserJet 500<sup>+</sup>** provides the same features as the **LaserJet<sup>+</sup>** printer with the addition of the dual cassettes, correct-order output and offset stacking. The differences between the **LaserJet** family printers are discussed in more detail later in this chapter.

The information supplied with your printer is divided into two main sources: this manual, which contains the more technical programming features of the **LaserJet** family printers, and the

LaserJet Printer Operator's Reference Manual (part no. 02686-90914) or the LaserJet 500+ Operator's Reference Manual (part no. 02686-90911). (Earlier printers were supplied with only one manual, the LaserJet Printer Owner's Manual, part no. 02686-90901.) For more information concerning installation, operation, maintenance, specifications, and general feature access, consult the operator's manual for your printer.

Since this manual contains information common to all LaserJet family printers, as well as specific information for each printer, please read the "How to Use This Manual" discussion on page 1-5 before trying to program any printer features.

This chapter contains the following information:

Introduction . . . . . 1-1  
Program Compatibility. . . . . 1-2  
The LaserJet Printer vs. the LaserJet<sup>+</sup> Printer . . . . . 1-3  
LaserJet 500<sup>+</sup> Printer Features. . . . . 1-5  
How to Use This Manual. . . . . 1-5  
How to Use Escape Sequences. . . . . 1-6  
Useful Information. . . . . 1-9  
Combining Escape Sequences. . . . . 1-10

## Program Compatibility

Hewlett-Packard has developed a "Printer Command Language" which standardizes printer features and user access of those features, providing compatibility between HP printers. The structure of the "Printer Command Language" consists of four levels of features:

- Level I Print and Space
- Level II EDP (Electronic Data Processing)
- Level III Word Processing
- Level IV Page Formatting

The **LaserJet** printer is a Level III printer, meaning that all applications written for Level I, II, and III printers will operate correctly on **LaserJet** with no modification. The **LaserJet<sup>+</sup>** and **LaserJet 500<sup>+</sup>** printers are level IV printers, meaning that all applications written for Level I, II, III, and IV printers will operate correctly on **LaserJet<sup>+</sup>** and **LaserJet 500<sup>+</sup>** printers with no modification

All **LaserJet** family printers support the following features, in addition to the standard Level III features, which take advantage of some of the printer's unique capabilities:

- Line termination
- End-of-line wrap-around
- Portrait/landscape orientation
- Select number of copies
- Paper input control

Applications written using these additional features may not operate as intended on other Hewlett-Packard printers which do not have these capabilities.

## **The LaserJet Printer vs. the LaserJet<sup>+</sup> Printer**

Chapter II describes features which are common to all **LaserJet** family printers and Chapter III describes only those features which are **LaserJet<sup>+</sup>** and **LaserJet 500<sup>+</sup>** features. In addition to the **LaserJet** printer features, the **LaserJet<sup>+</sup>** and **LaserJet 500<sup>+</sup>** printers have the following features:

- Easily-selectable downloadable soft fonts
- Macros for overlay forms and other frequently-used commands and text
- Printer memory usage controlled by the user

- Gray scale, patterns, and rules (solid black lines)
- Twenty-position stack for holding and recalling cursor position
- Dot moves for precise dot positioning
- Fractional decipoint cursor moves
- Centronics Parallel interface option for reduced graphics and font download communication time
- Data transfer indicator (READY indicator flashes during transfer)
- Reset possible via Operator Control Panel
- 512 Kbyte memory (4 times LaserJet)
- User memory 395 Kbytes (6 times LaserJet)
- Full-page raster graphics at 150 dpi (32 square inches at 300 dpi)
- Auto-continue mode (allows printer to continue printing after certain errors are displayed)
- Printer automatically goes on-line when paper trays are inserted

The LaserJet<sup>+</sup> and LaserJet 500<sup>+</sup> printers also have seven additional internal fonts:

- Courier typeface, both orientations, USASCII & Rom. Ext. symbol sets, 10 pitch, 12 pt., Upright style, Med. stroke weight
- Line Printer typeface, Portrait orientation, Roman-8, USASCII & Rom. Ext. symbol sets, 16.66 pitch, 8.5 pt., Upright style, Light stroke weight

# LaserJet 500+ Printer Features

The LaserJet 500+ printer has the same features as the LaserJet+ with the addition of the dual input trays and larger output stacker.

The LaserJet 500+ printer has manually-selectable correct-order/reverse-order stacking. The printer also has programmatically-controlled job offsetting and paper bin selection.

## How to Use This Manual

This manual is organized so that the general information concerning escape sequences is described at the beginning of the manual (Chapter I), and this is followed by a description of printer features and how to use them. The printer features are grouped together by their applications and the feature discussions contain examples to illustrate their use. Once you have a general knowledge of using escape sequences (after you have read Chapter I), you may skip to the chapter of the manual that explains the application you are interested in. The table below lists each LaserJet family printer and the chapters that pertain to each of them:

| <u>PRINTER</u> | <u>PERTINENT CHAPTERS</u> |
|----------------|---------------------------|
| LaserJet       | I, II, V                  |
| LaserJet+      | I, II, III, V             |
| LaserJet 500+  | I, II, III, IV, V         |

Features common to all LaserJet family printers are described in Chapter II. Chapter III describes printer features that are only supported for LaserJet+ and LaserJet 500+ printers. Chapter IV explains the dual input tray features specific to the LaserJet 500+ printer. Chapter V contains tips and techniques that may help you with a particular problem.

The Appendices contain a summary of the escape sequences, ASCII tables, and instructions for changing baud rate and switching the serial interface from RS-232C to RS-422. The Centronics Parallel Interface is also discussed, along with interface configuration information and cable pin assignments. A glossary of terms is contained in the back of the manual to assist you if you run into any terminology problems, and an index is supplied to allow quick reference to any subject in the manual.

## How to Use Escape Sequences

An escape sequence is a string of characters, beginning with the "escape character", which selects one of the printer's features, such as raster graphics, number of copies, landscape orientation, etc. The escape character ( $E_c$ ) is also called a control code or control character-- it "controls" the action of the printer, so to speak.

The escape character is not a printable character (like numbers and letters). Its function is to let the printer know an escape sequence is on the way. When an escape sequence is sent to the printer, the printer knows that the next several characters will not be printed as text, but will be used to access one of the printer's features.

An escape sequence consists of the escape control code ( $E_c$ ) followed by one or more characters in succession. Both two-character and parameterized escape sequences control the LaserJet family printers. Two-character escape sequences take the form  $E_cX$ , where X is a character from the ASCII table ("0" through "~" -- see ASCII tables in Appendix B). If a character within the range "!" through "/" is received, the escape sequence is parameterized. Parameterized escape sequences are structured in the following form:

$E_c X y \# Z$  [binary data]

- X     **PARAMETERIZED CHARACTER**--Any character from the ASCII table within the range "!" through "/". The purpose of such a character is to indicate that the escape sequence is parameterized.



- y** **GROUP CHARACTER**--Any character from the ASCII table with n the range " ' " through "~". The purpose of the group character is to specify the group or type of control being performed.
- #** **VALUE FIELD**--A group of characters specifying a numeric value. The numeric value is represented as an ASCII string of digits (0 through 9) which may be preceded by a "+" or "-" sign and succeeded by a fractional portion via use of a decimal point (.). If an escape sequence contains a value field and a value is not specified, then a value of zero is assumed.
- Z** **TERMINATING CHARACTER**--This ASCII character indicates the parameter to which the previous value applies. If this character is lower case (a, b, c, etc.), it indicates a combined escape sequence, meaning that more parameterized information will follow. If the character is upper case (A, B, C, etc.), it terminates the escape sequence string.

**Data** **BINARY DATA**--Binary data may follow the terminating character in some escape sequences. The number of data bytes which follow is specified in the value field.

The following examples will provide additional explanation of escape sequences:

**EXAMPLE 1:**  $\text{^cE}$  is a two-character escape sequence used for resetting the printer. If the character following the escape character is between "0" and "~" in the ASCII table, the escape sequence is interpreted as a two-character sequence.

**EXAMPLE 2:**  $\text{^c&k2S}$  is a parameterized escape sequence which selects a compressed-print font. The first two characters following the escape character (&k) indicate to the printer the type of function to be performed. The parameter (2) in conjunction with the terminating character (S) specify the compressed printing mode.

**EXAMPLE 3:**  $\text{^c*b5W[binary data]}$  is a parameterized escape sequence which is used to transfer raster graphics to the printer. The first two characters following the  $\text{^c}$  character (\*b) indicate that the sequence is a raster graphics transfer. The value in the

value field (5), in conjunction with the terminator (W), indicates that 5 bytes of binary data will follow. The binary data is the raster graphics data **(the left and right brackets are not actually part of the escape sequence, but are shown here for clarity).**

While we are discussing escape sequences, skip to Appendix B and look at the ASCII table starting on page B-2. Look in the left column of the table and notice that the ASCII character for the "<" character, for example, is equivalent to a decimal 60, an octal 074, or a hex 3C. Many software packages or programming languages will require you to use a decimal or hex equivalent for ASCII characters. With the information you have just learned, finding equivalents for ASCII characters is as easy as referencing the ASCII table.

# Useful Information

The LaserJet family printers allow you to print in either portrait (vertical) or landscape (horizontal) orientation. Formatting is based on the mode selected (default is portrait mode) and the page size selected (either the default size as contained in the input paper cassette or the size selected using the  $\text{E}_c\&\#P$  sequence).

The printer strips unuseable escape sequences and control codes from the data that is sent to the printer. Therefore, if you send a sequence that is not supported or recognized (because of a syntax error, for example), the printer will ignore it and no error will be reported.

All of the features selected using escape sequences are active until specifically deactivated using another escape sequence (or when power-up or reset occurs). For example, if automatic underlining is activated using the  $\text{E}_c\&dD$  sequence, all following characters will be underlined until you send an  $\text{E}_c\&d@$  (disable auto-underlining).

Many of the escape sequences contain the lower case letter L (l) and the number one (1)—or the upper case letter O (O) and the number zero (0). Since the subtle differences between the characters can be confusing, take a minute to compare the characters so that you can avoid later confusion (on some terminals, they may even look the same— if your escape sequence isn't working properly, this could be the problem):

|                  |                  |
|------------------|------------------|
| Lower case L – l | Upper case O – O |
| Number one – 1   | Number zero – 0  |

If the value field (#) in any of the escape sequences is *not* specified, the default will be a zero in the value field. For example, the sequences  $\text{E}_c\&a0L$  and  $\text{E}_c\&aL$  are equivalent.

# Combining Escape Sequences

To save keystrokes, you can combine several escape sequences into one escape sequence string. For example, to set the top margin to line 10 and the text length to 70 lines you could send either:

`^c&110E` and `^c&170F`  
or  
`^c&110e70F`

There are three important rules to remember in combining escape sequences:

- The first two characters after the `^c` character must be the same. In the example above, these are "&" and "l". The escape character and the first two characters following it are specified only once in a string of combined escape sequences.
- The final character of the individual internal escape sequences must be lower case. In the example above, "E" becomes "e". The final character of the last escape sequence must be upper case ("F" in this example).
- The escape sequences will be performed in the order in which they are specified.

---

## Chapter II

---

---

# LASERJET PRINTER FAMILY FEATURES

---

---

## Introduction

This chapter describes printer features that are common to all LaserJet family printers (**LaserJet**, **LaserJet<sup>+</sup>**, and **LaserJet 500<sup>+</sup>**). The supported control codes are described first, followed by the supported escape sequences. Each escape sequence is explained and examples are given for clarity. This chapter contains the following information:

|  |      |
|--|------|
| Control Codes . . . . .                          | 2-3  |
| Page Formatting . . . . .                        | 2-4  |
| The Default Page Format . . . . .                | 2-6  |
| Specifying Page Length (Size of Paper) . . . . . | 2-7  |
| Setting the Top Margin . . . . .                 | 2-9  |
| Text Length Selection . . . . .                  | 2-10 |
| Vertical Line Spacing . . . . .                  | 2-11 |
| Horizontal Cursor Spacing . . . . .              | 2-12 |
| Setting and Clearing Side Margins . . . . .      | 2-13 |
| Example: Page Formatting . . . . .               | 2-14 |

|  |      |
|--|------|
| Cursor Positioning . . . . .   | 2-15 |
| Horizontal Cursor Positioning (Using Columns) . . . . .              | 2-15 |
| Vertical Cursor Positioning (Using Lines) . . . . .                  | 2-16 |
| Horizontal Cursor Positioning (Using Decipoints) . . . . .           | 2-17 |
| Vertical Cursor Positioning (Using Decipoints) . . . . .             | 2-18 |
| Selecting Character Fonts . . . . .                                  | 2-19 |
| Character Font Orientation . . . . .                                 | 2-23 |
| Default Font Characteristics & Resident Fonts . . . . .              | 2-24 |
| Symbol Set Selection . . . . .                                       | 2-25 |
| Proportional vs. Fixed Spacing . . . . .                             | 2-27 |
| Font Pitch Selection . . . . .                                       | 2-28 |
| Character Height (Point Size) Selection . . . . .                    | 2-29 |
| Character Style (Italic/Upright) . . . . .                           | 2-30 |
| Stroke Weight . . . . .  | 2-31 |
| Typeface Selection . . . . .   | 2-32 |
| Example: Selecting A Character Font . . . . .                        | 2-33 |
| Switching Between Primary and<br>Secondary Character Fonts . . . . . | 2-34 |
| Raster Graphics . . . . .  | 2-35 |
| Raster Graphics Resolution . . . . .                                 | 2-36 |
| Start Raster Graphics . . . . .                                      | 2-38 |
| Transfer Raster Graphics . . . . .                                   | 2-38 |
| End Raster Graphics . . . . .  | 2-39 |
| Example: Raster Graphics . . . . .                                   | 2-40 |
| Miscellaneous Features . . . . .                                     | 2-42 |
| Display Functions . . . . .  | 2-42 |
| Transparent Print Data . . . . .                                     | 2-43 |
| Perforation Skip Mode . . . . .                                      | 2-43 |
| Character Overstrike . . . . .                                       | 2-44 |
| Automatic Underlining . . . . .                                      | 2-44 |
| Half Line Feed . . . . .   | 2-45 |
| Line Termination . . . . .   | 2-45 |
| End-Of-Line Wrap . . . . .   | 2-46 |
| Portrait & Landscape Orientation . . . . .                           | 2-46 |
| Select Number of Copies . . . . .                                    | 2-47 |
| Paper Input Control . . . . .  | 2-47 |
| Specialized Printer Control . . . . .                                | 2-48 |
| Reset . . . . .  | 2-48 |
| Self-Test . . . . .  | 2-51 |

# Control Codes

The following control codes are used to select the features listed. The escape control code ( $E_C$ ) is used in the form of escape sequences to select most of the printer's programmable features.

TABLE 2-1. CONTROL CODES

|                 |       |   |
|-----------------|-------|---|
| Backspace       | $B_S$ | Move one column left  |
| Line Feed       | $L_F$ | Move to next print line while maintaining current column position                                   |
| Form Feed       | $F_F$ | Move to first line at top of the next page while maintaining current column position                |
| Carriage Return | $C_R$ | Move to the left margin on current print line   |
| Shift Out       | $S_O$ | Select characters that follow from the current secondary character font until receipt of a Shift In |
| Shift In        | $S_I$ | Select characters that follow from the current primary character font until receipt of a Shift Out  |
| Escape          | $E_C$ | Indicates the beginning of a special control sequence (escape sequence)                             |

The following table lists each control code and the characters used to perform control features (using keyboard keys or BASIC programming language).

TABLE 2-2. ACCESSING CONTROL CODES FROM THE KEYBOARD AND BASIC

|                                   | <u>Control Code</u> | <u>BASIC</u> |
|-----------------------------------|---------------------|--------------|
| Backspace ( <sup>B</sup> s)       | CTRL H              | CHR\$( 8)    |
| Line Feed ( <sup>L</sup> F)       | CTRL J              | CHR\$(10)    |
| Form Feed ( <sup>F</sup> F)       | CTRL L              | CHR\$(12)    |
| Carriage Return ( <sup>C</sup> R) | CTRL M              | CHR\$(13)    |
| Shift Out ( <sup>S</sup> o)       | CTRL N              | CHR\$(14)    |
| Shift In ( <sup>S</sup> i)        | CTRL O              | CHR\$(15)    |
| Escape ( <sup>E</sup> c)          | CTRL [              | CHR\$(27)    |

## Page Formatting

Formatting a page for printing involves setting the page length, top margin, text length, and left and right margins. (Page orientation is also related to formatting—orientation is discussed in the "Portrait & Landscape Orientation" description in this chapter.) The following drawing illustrates these parameters and the following paragraphs explain how you may set them to the values you want.



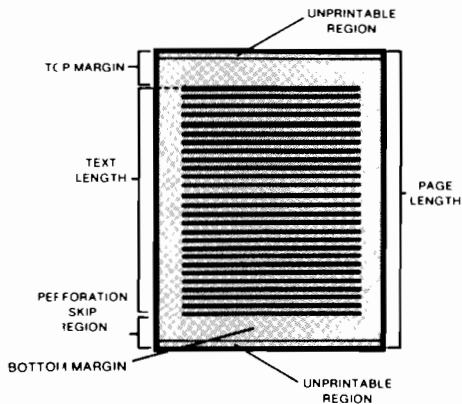

Figure 2-1. Page Formatting Parameters

---

**NOTE**

There is an unprintable region along the outside edges of the page. Table 5-2 of this manual lists the printable area for the various paper sizes. If printing is attempted outside the printable area, data will be lost. A useful general rule is to avoid trying to print within one quarter-inch of the top and bottom edges of the page.

The printer powers up with a top margin of one-half inch, a perforation skip region (bottom margin) of one-half inch, and with perforation skip mode enabled.

---

# THE DEFAULT PAGE FORMAT

The default page format for both portrait and landscape orientations is illustrated below:

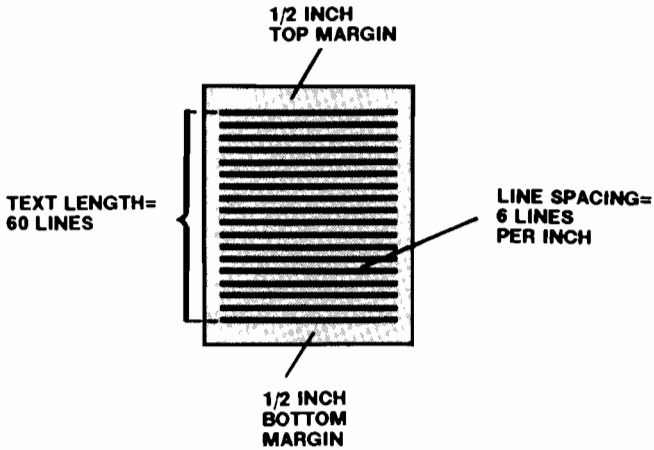

Figure 2-2. Default Page Format–Portrait

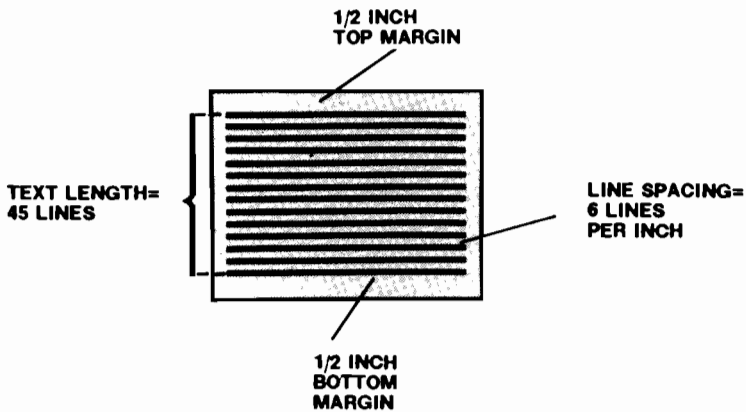

Figure 2-3. Default Page Format–Landscape

## SPECIFYING PAGE LENGTH (SIZE OF PAPER)

The page length can be specified using the `Esc&l#P` escape sequence. The value field (#) specifies the page length (size of paper) in number of lines (using the currently selected line spacing). For example, to set a page length of 54 lines (9 inches at 6 lines/inch), the `Esc&l54P` escape sequence would be sent to the printer. **NOTE: The line spacing can be changed using the Vertical Line Spacing escape sequences explained later in this chapter.**

If an **input paper cassette** is installed in the printer, the page size defaults to the size of the installed paper. If an **input paper cassette** is not installed, the printer defaults to letter-size page length (8.5 x 11 inches).

Specifying a page length of `0` (`Esc&l0P`) defaults the page size to the size of the *installed* paper cassette (The LaserJet 500+ printer defaults to the paper size of the *selected* cassette). If the printer is in manual feed mode and a page length of `0` is specified, the page size will default to the cassette size that was set before entering manual feed mode.

---

### NOTE

Whether printing in landscape or portrait orientation, the page length is always specified as the physical length (not width) of the paper. If you decide to change to landscape orientation, specify page length first, then change orientation.

---

The table below lists the specific range of values (#) to select the corresponding input paper cassette size:

| <u>Paper Cassette Size</u> | <u>Value Field (#)</u> |              |
|----------------------------|------------------------|--------------|
|                            | 6 Lines/Inch           | 8 Lines/Inch |
| Letter                     | 61 - 66                | 81 - 88      |
| A4                         | 67 - 70                | 89 - 93      |
| Legal                      | 71 - 84                | 94 - 112     |
| B5                         | 1 - 60                 | 1 - 80       |
| Default *                  | 0                      | 0            |

\* Defaults to size of installed paper tray

**NOTE:** Although the above table lists the range of values that indicate the input cassette size, the best method of selecting the page length is to specify the exact number of lines. For example, even though any value between 61 and 66 indicates letter-size paper (8 1/2 x 11 inches), specify the page length as 66 (6 lines/inch x 11 inches = 66 lines). Specifying values other than the exact paper size limits the number of addressable lines.

Upon receipt of a legal page length command, the printer defaults the top margin, text length, and left and right margins. If a paper size greater than maximum (14 inches) is requested, or if the vertical line spacing is set to zero, the page length command is ignored.

If the printer is in the manual feed mode, the page length defaults to the currently loaded paper size (or if no cassette is loaded, letter-size paper).

If an escape sequence specifies a page length that is different than the paper that is loaded, the printer alternately flashes "PC" and the size of cassette specified (L=letter, LL=legal, A4=A4, and b5=B5) and places the printer off-line--this lets the operator know which cassette should be loaded in the printer. (The CONTINUE key must be pressed to get back on-line.) **NOTE:** When the printer receives the  $\text{E}_c\&l\#P$  escape sequence, it prints the buffered pages that are stored in the printer (before requesting a change).

## SETTING THE TOP MARGIN

The top margin can be specified anywhere within a page, whether the page has been programmatically set or defaulted. The following sequence is used to set the top margin:

Set top margin     $\text{E}_c\&\text{I}\#\text{E}$

# = Number of lines to skip

The value field (#) specifies the number of lines to skip at the top of the page. The top margin may range from zero to the page length (the default is one-half inch from the top of the page). Setting a top margin causes the text length to be defaulted (page length - top margin - 1/2 inch bottom margin = default text length). **NOTE: Avoid using a value field of zero or one because the top two lines of the page (approximately) lie in the unprintable region. Attempting to print on these two lines will result in data loss.**

The top margin escape sequence can be placed anywhere within the page. It should be noted, however, that if the cursor is below the newly-specified top margin at the time it is specified, the cursor will not move to the top margin unless a  $\text{E}_c\&\text{a}\text{0}\text{R}$  sequence (vertical cursor move to line 0) is sent. Otherwise, printing will begin at the current cursor position on the current page (and not at the top margin until the following page).

If the vertical motion index is set to zero or if a top margin beyond the current page length is selected, the command will be ignored.

The top margin uses the current vertical line spacing when determining the top margin position. Once the top margin is set, successive changes in the vertical line spacing do not affect the top margin. **NOTE: The line spacing can be changed using the Vertical Line Spacing escape sequences explained later in this chapter.**

---

**NOTE**

HP LEVEL III printers allow you to set the top margin either programmatically (as the LaserJet family printers do), or by physically setting the paper to the desired starting position (line zero). To keep your programming application compatible with other HP LEVEL III printers, use the top margin escape sequence only at the beginning of the job.

---

## TEXT LENGTH SELECTION

Text length is defined as the page length minus the top and bottom margins. Since it is only possible to specify page length, top margin, and text length, setting the text length specifies the size of the bottom margin.

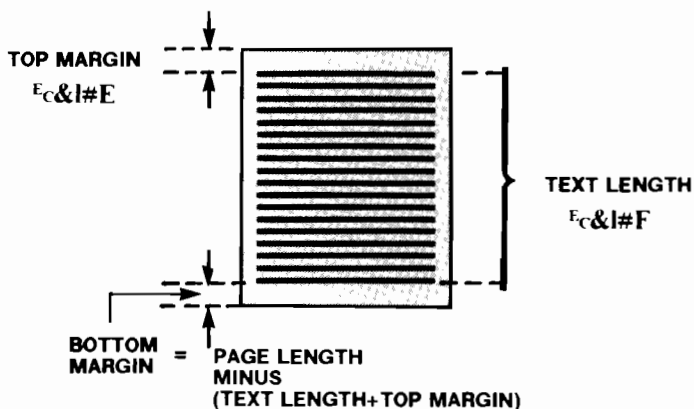

Figure 2-4. Text Length and Bottom Margin

Text length is set by sending the following sequence:

Set text length  $\text{E}_c\&l\#F$

# = Number of text lines/page

The value field (#) specifies the number of lines of text you wish to put on your page. If a text length greater than the page length minus the top margin is specified, the command will be ignored.

If a text length of zero is sent to the printer, the text length is defaulted. The default text length, which is set any time the page orientation, page length, or top margin is changed, is one-half inch less than the maximum allowable text length (the page length minus the top margin). In other words, the default bottom margin is 1/2 inch.

## VERTICAL LINE SPACING

Vertical line spacing can be set using either of two methods: lines per inch spacing or vertical motion index (VMI). Lines per inch spacing is most generally used, as it is usually the easiest to calculate. VMI is used to specify non-integer spacing values such as 1.75 or 2.6 lines per inch. **NOTE: The escape sequence most recently received will be in effect.**

The vertical line spacing affects the line feed, half line feed and row/column cursor spacing—regardless of which method is used.

(The escape sequence for half line feed is discussed later in this manual.)

### Setting Lines Per Inch

Set the vertical spacing increment in lines per inch by sending the following escape sequence:

$\text{E}_c\&l\#D$

# = Number of lines/inch

The value field (#) specifies the number of lines per inch. The possible values are 1, 2, 3, 4, 6, 8, 12, 16, 24, and 48 lines per inch. The default line spacing is six lines per inch. If a request is made for a line spacing which is not supported by the printer, the command will be ignored.

To set your vertical line spacing to 8 lines per inch, for example, send the `Esc&l8D` escape sequence to the printer.

## Setting Vertical Motion Index

Instead of setting the vertical spacing in terms of lines per inch, the spacing can be set in 1/48 inch increments. This setting is called the vertical motion index (VMI). To set the vertical motion index, send the following escape sequence to the printer:

`Esc&l#C`

# = Number of 1/48 inch increments per line

The value field (#) specifies the number of 1/48 inch increments you wish to use to space one line. For example, a value field of 6 would set the line spacing to 6/48 inch (6/48 inch = 1/8 inch = 8 lines per inch). The available range of values is 0 to 126 and can be specified to four decimal places.

## HORIZONTAL CURSOR SPACING

The font pitch (horizontal spacing increment) can be overridden using the horizontal motion index (HMI) escape sequence as follows:

`Esc&k#H`

# = Number of 1/120 inch increments per character

The value field (#) specifies the number of 1/120 inch increments to be used for horizontal cursor movement (values range from 0 to 126 and are valid to four decimal places). For example, to set the HMI to 10 characters per inch, the `Esc&k12H` escape sequence



would be sent to the printer. To set the HMI for 12 pitch, the `Esc&k10H` escape sequence would be sent.

HMI defaults when character font orientation, symbol set, pitch, proportional spacing, or height of the invoked font is changed. HMI also defaults when switching between primary and secondary fonts (using Shift In and Shift Out). Thus, for example, if you set the HMI to a different value than the character font pitch, then shift out to an alternate character font, and then shift back, it will be necessary to re-specify the HMI. When HMI defaults, it is set according to the width of the Space character of the selected font.

When proportional fonts are selected, only the Space character is affected by the HMI; the default HMI is equal to the width of the Space character. When non-proportional fonts are selected, all printable characters (including Space and Backspace) are affected by the HMI setting (by changing the HMI, a 10-pitch font could be printed at 12 cpi, for example).

## SETTING AND CLEARING SIDE MARGINS

### SETTING SIDE MARGINS

The left and right margins can be set by sending the following escape sequences to the printer:

Set left margin     `Esc&a#L`

Set right margin    `Esc&a#M`

# = Column number



The value field (#) specifies the column number, with the first column in a line being column zero. If a column number is specified that would place the left margin to the right of the right margin (or vice versa), the command will be ignored. Column positions vary depending on the print pitch of the character font in use. (Proportional character fonts use the width of the SPACE character to determine column positions.) The default margins are column zero (left margin) and the rightmost printable limit (right margin). **NOTE: See Appendix D of the LaserJet Printer**

**Operator's Manual for information on the maximum printable area for various paper sizes.**

**BASIC Example:**

```
100 REM ----- Set Left Margin -----
110 REM --- notice the '#' has been replaced by ---
120 REM --- a character position -----
130 LPRINT CHR$(27);"&a30L" : REM escape to set margin
140 LPRINT "The Laserjet, an 8 page-per-minute"
150 LPRINT "laser printer, is capable of producing"
160 LPRINT "letter-quality print with almost no sound."
170 LPRINT CHR$(27);"&a0L" : REM escape to reset margin
180 LPRINT "The Laserjet printer is also capable "
190 LPRINT "of producing raster graphics. "
200 LPRINT CHR$(12);:REM -Form Feed-
```

**CLEARING SIDE MARGINS**

To clear the left and right margins, send the  $\text{E}_c9$  escape sequence. The margins will be set to their default values. **NOTE: Send a Carriage Return following the  $\text{E}_c9$  to return the cursor to the left margin.**

**EXAMPLE: PAGE FORMATTING**

The following two examples illustrate how, by varying the vertical line spacing, you can print 66 lines on a letter-size paper (portrait mode) or 72 lines on an A4-size page (landscape).

To print 66 lines on a letter-size page in portrait mode, you can send the  $\text{E}_c\text{E}_c\&17.27\text{c}66\text{F}$  escape sequence to the printer.

To print 72 lines on an A4-size page in landscape mode with compressed print, you can insert the 92286A font cartridge and send the  $\text{E}_c\text{E}_c\&k2\text{S}_c\&1104.8\text{c}72\text{F}$  escape sequence to the printer.

The above two examples, by decreasing the vertical line spacing, illustrate how to print the stated number of lines without entering the unprintable region of the page.

# Cursor Positioning

All LaserJet family printers allow cursor positioning using rows/columns and decipoints. Both methods are explained below.

**NOTE:** The terms "cursor position" and "current active position" are used interchangeably in this manual. (LaserJet+ and LaserJet 500+ printers also allow cursor positioning in dots, in addition to rows/columns and decipoints—see Chapter III.)

## HORIZONTAL CURSOR POSITIONING (USING COLUMNS)

The following escape sequence moves the current active cursor position to a new character position on the current line. This movement is based on the current print pitch (or Space character width for proportional fonts).

`Esc&a#C`

# = Horizontal position (in columns)

The value field (#) specifies the horizontal position; a plus (+) or minus (-) sign in front of the value indicates the new position is relative to the current active position (+ moves cursor # columns to the right and - moves cursor # columns to the left). When no plus or minus sign is indicated in the value field, the position is absolute—the first column in the line being column 0. To move the current active printing position to column 47, for example, you would send the `Esc&a47C` escape sequence. Another way to do this, assuming you are at column 40 and wish to move to column 47, is to send the `Esc&a+7C` sequence—the +7 in the value field specifies that you want to move 7 columns to the right of your current position.

This escape sequence ignores margins and can therefore be used to set the current active position to any location along the present line (within the physical limits of the printer). If a request is made for a location outside the printer's physical limits, the current active position will be moved to the limit on that side (left or right). **NOTE:** Chapter IV of this manual lists the maximum printable limits of the LaserJet family printers.

## BASIC Example:

```
100 REM --- Horizontal Cursor position Movement ---
110 REM --notice '#' replaced by column position--
120 LPRINT CHR$(27);"&a10C";"Column 10"
130 LPRINT CHR$(27);"&a40C";"Column 40"
140 LPRINT CHR$(27);"&a60C";"Column 60"
150 LPRINT CHR$(27);"&a50C";"Column 50";
160 FOR A=1 TO 5:LPRINT:NEXT A
170 REM --this loop prints diagonal pattern -----
180 FOR N=0 TO 80 STEP 5:LPRINT CHR$(27);"&a";N;"C";N
190 NEXT N
200 LPRINT CHR$(12); :REM --Form Feed--
```

## VERTICAL CURSOR POSITIONING (USING LINES)

The following escape sequence moves the current active printing position to the same column position on a new line:

$E_c&a\#R$

# = Vertical position (in lines)

The value field (#) specifies the new vertical position (in number of lines); a plus (+) or minus (-) sign in front of the value indicates the new position is relative to (down or up from) the current active position--no plus or minus sign indicates that the new position is an absolute line number. For example, to move the cursor from line number 5 to line number 1, you could send either the  $E_c&a1R$  sequence or the  $E_c&a-4R$  sequence. **NOTE:** The distance the cursor moves per line is determined by the current vertical line spacing.

Absolute or relative requests which exceed the physical limits of the printer will move the cursor to the appropriate limit. The first line within a form (specified by the top margin) is line zero. Absolute positioning is in respect to the top margin. Positive relative positioning allows you to move the cursor the specified number of lines off the current page, causing a page eject. Vertical cursor positioning ignores the perforation skip mode, allowing the cursor to move into the bottom margin.

## BASIC Example:

```
100 REM — Vertical Cursor position Movement —
110 REM -notice '#' has been replaced by line number-
120 LPRINT CHR$(27);"&a20R";"Line 20 - Twenty - Line 20 "
130 LPRINT CHR$(27);"&a15R";"Line 15 - Fifteen - Line 15"
140 LPRINT CHR$(27);"&a32R";"Line32-Thirty-Two-Line 32"
150 LPRINT CHR$(27);"&a25R";"Line 25-Twenty-Five-Line 25"
160 REM — this loop prints data in lines 20 to 40
170 FOR N=20 TO 40
180 LPRINT CHR$(27);"&a";N;"R";
190 LPRINT "          line number ";N
200 NEXT N
210 LPRINT CHR$(12); :REM -Form Feed-
```

## HORIZONTAL CURSOR POSITIONING (USING DECIPPOINTS)

The following escape sequence moves the cursor horizontally in 1/720 inch increments (decipoints). This sequence ignores margins and can therefore be used to move the cursor to any point along the present line (within the physical limits of the printer).

**Esc&a#H**

# = Horizontal position (in decipoints)

The value field (#) specifies the new horizontal position in decipoints— a plus (+) or minus (-) sign before the decipoint value specifies that the position is relative to the current active position (+ moves cursor right; - moves cursor left)—no plus or minus sign indicates that the cursor move is absolute, with the left-most printable limit of the page being position zero. **NOTE: LaserJet<sup>+</sup> and LaserJet 500<sup>+</sup> printers allow you to specify fractional decipoint values to two places after the decimal.**

## BASIC Example:

```
100 REM -- Horizontal Cursor position Movement -----
110 REM --notice '#' replaced by decipoint position--
120 LPRINT CHR$(27);"&a100H";"Position 100"
130 LPRINT CHR$(27);"&a1500H";"Position 1500"
140 LPRINT CHR$(27);"&a4000H";"Position 4000"
150 LPRINT CHR$(27);"&a3000H";"Position 3000";
160 FOR A=1 TO 5:LPRINT:NEXT A
170 REM --loop prints downward diagonally-----
180 FOR N=0 TO 2500 STEP 250
190 LPRINT CHR$(27);"&a";N;"H";N
200 LPRINT CHR$(27);"&a";N+2500;"H";"POSITION";N+2500;
210 NEXT N
220 LPRINT CHR$(12); :REM --Form Feed--
```

## VERTICAL CURSOR POSITIONING (USING DECIPOINTS)

The following escape sequence moves the current active position to a new vertical position in 1/720 inch increments (decipoints).

$\text{F}_c\&a\#V$

# = Vertical position (in decipoints)

The value field (#) specifies the new vertical position in decipoints— a plus (+) or minus (-) sign before the decipoint value specifies that the position is relative to the current active position (+ moves cursor downward and - moves cursor upward)—no plus or minus sign indicates that the cursor move is absolute, with the zero position defined as the top margin and the bottom determined by the bottom of the page. Vertical cursor positioning ignores the perforation skip mode, allowing the cursor to move into the top or bottom margin. **NOTE: LaserJet<sup>+</sup> and LaserJet 500<sup>+</sup> printers allow you to specify fractional values to two places after the decimal.**

## BASIC Example:

```
100 REM ---Vertical Cursor position Movement ---
110 REM -notice '#' replaced by Decipoint Position-
120 LPRINT CHR$(27);"&a360V";"1/2 FROM TOP MARGIN"
130 LPRINT CHR$(27);"&a720V";"1 FROM TOP MARGIN"
140 LPRINT CHR$(27);"&a1440V";"2 FROM TOP MARGIN"
150 LPRINT CHR$(27);"&a2880V";"4 FROM TOP MARGIN"
160 LPRINT CHR$(12);:REM -Form Feed-
```

## Selecting Character Fonts

The LaserJet family printers, with an optional font cartridge installed, have the ability to print several different character fonts, with a maximum of 8 fonts per page. (The LaserJet<sup>+</sup> and LaserJet 500<sup>+</sup> printers print a maximum of 16 fonts per page.) Each character font is selected from an installed font cartridge or the printer's memory by specifying the font's characteristics such as orientation, height, typeface, etc. Many word processing packages will perform this task for you. If your word processor, or other software you are using, does not have this capability, you can use escape sequences for character font selection. You may specify (using escape sequences) all the characteristics of a character font or just some of those characteristics—for either a primary or secondary font. The printer, upon receiving the font selection escape sequences, *selects the best fitting character font from those available, with the best fitting font depending on the specified font characteristics and their priority.* Only those fonts available can be selected. Selecting the characteristics of an unavailable font causes the font closest to the specified font to be selected.

The list below contains the font characteristics, listed in descending order of priority.

- Printing orientation (portrait vs. landscape)
- Symbol set (Roman-8, Line draw, Math etc.)
- Proportional spacing vs. fixed spacing (non-proportional)
- Print pitch (for non-proportional fonts only)

- Character height (point size)
- Character style (upright vs. italic)
- Stroke weight (light, medium, and bold)
- Typeface (Courier, Pica, Elite, etc.)

If the above font characteristics are not specified when selecting a character font, the printer will remain set to the characteristics *last specified*. For example, if you wish to select a font without selecting a point size, the default point size will be the size last requested (or the power-up default if no point size was requested since the last reset or power-up).

The following table shows the characteristics of the printer's two internal fonts (A and B) and the characteristics of the fonts in a sample font cartridge (C, D, and E). Font A is the default character font; when the printer is powered-up or reset ( $E_cE$ ), the default character font becomes active and all characteristics are set to those of the default font. *It is important to remember that, when selecting character fonts, the printer chooses the available font that best matches the characteristics last specified, with the priority of the characteristics being as previously indicated. The following pages explain what happens if you specify a characteristic which does not exist in the default set or installed font cartridge.*

To illustrate how the printer chooses the best-fitting character font from those available, the following example is provided. This example assumes that a font cartridge is loaded into the printer. With this cartridge loaded, the five character fonts (A through E) listed in the following table are accessible. To demonstrate how the font selection process works, we will send the following escape sequence to the printer to select font A:

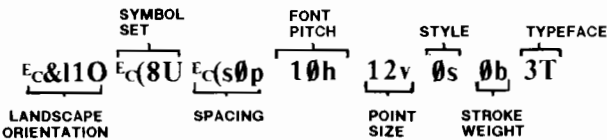



The above escape sequence specifies the font characteristics (for a primary font) in order of priority from left (orientation—highest priority) to right (typeface—lowest priority). When the printer receives this escape sequence, the orientation escape sequence has the highest priority. Since this sequence specifies portrait orientation, only fonts A, C, and D are eligible for selection because their orientation is portrait. The specified symbol set has the next highest priority, and this sequence specifies Roman-8. Since fonts A, C, and D are both portrait fonts and use the Roman-8 symbol set, all three of these fonts are still "eligible" for selection. The next three font characteristics—spacing, pitch, and point size—are the same for all three fonts, so at this point, all three fonts are still eligible for selection. The font characteristic with the next priority, style, narrows the choice of fonts to fonts A and C, since font D is an italic font. The stroke weight escape sequence specifies font A, since font C is a bold font. The typeface escape sequence (lowest priority) specifies the Courier typeface, which corresponds to font A's typeface. It is important to note that even if this example escape sequence specified another typeface, such as Line Printer, font A would still be selected since it is the only remaining font. Had italic style been specified instead of upright, font D would have been selected because style has higher priority than stroke weight.

Here is another example of selecting a character font. This example describes a somewhat different way of selecting a specific character font. Using the same example cartridge, you could send the following sequence to select font E (after selecting font A as above):

`Esc&110Esc(s16.66H`

At this point, since we have just specified font A, the specified characteristics of font A are stored in the printer's memory. Therefore, to specify font E, we only need to send escape sequences for those characteristics of font E that differ from those of font A. The first escape sequence we need to send specifies landscape orientation. This sequence narrows the choice of fonts to fonts E and E, since they are the only landscape fonts available and orientation is the characteristic of highest priority. Fonts B and E both use the Roman-8 symbol set and fixed spacing, so re-specifying these characteristics is unnecessary.

However, the next priority font characteristic is pitch and fonts B and E have different pitches. Specifying 16.66 pitch will select font E as the primary character font.

INTERNAL FONTS (Standard Printer)

|               | A*       | B         |
|---------------|----------|-----------|
| Orientation   | Portrait | Landscape |
| Symbol Set    | Roman-8  | Roman-8   |
| Spacing       | Fixed    | Fixed     |
| Pitch         | 10       | 10        |
| Point Size    | 12       | 12        |
| Style         | Upright  | Upright   |
| Stroke Weight | Medium   | Medium    |
| Typeface      | Courier  | Courier   |

EXAMPLE FONT CARTRIDGE

|               | C        | D        | E         |
|---------------|----------|----------|-----------|
| Orientation   | Portrait | Portrait | Landscape |
| Symbol Set    | Roman-8  | Roman-8  | Roman-8   |
| Spacing       | Fixed    | Fixed    | Fixed     |
| Pitch         | 10       | 10       | 16.66     |
| Point Size    | 12       | 12       | 8.5       |
| Style         | Upright  | Italic   | Upright   |
| Stroke Weight | Bold     | Light    | Light     |
| Typeface      | Courier  | Courier  | Line Pr.  |

\* Fonts A and B are resident in the printer's memory. Font A is the default font. (Therefore, when reset, all font characteristics are set as in this font.) Fonts C, D, and E represent an example font cartridge.

Each of the above-mentioned character font characteristics is specified using escape sequences. Each of these escape sequences will now be explained, followed by an example of selecting a specific character font.

## CHARACTER FONT ORIENTATION

The LaserJet family printers can print characters in either of two orientations: portrait (text printed from left-to-right across the width of the page) or landscape (text printed from left-to-right across the length of the page). The escape sequence `^c&100` selects the portrait mode (default) and `^c&110` selects the landscape mode. Once the orientation is selected, only those fonts that are available in that orientation are printable. The following illustration shows the difference between portrait orientation and landscape orientation.

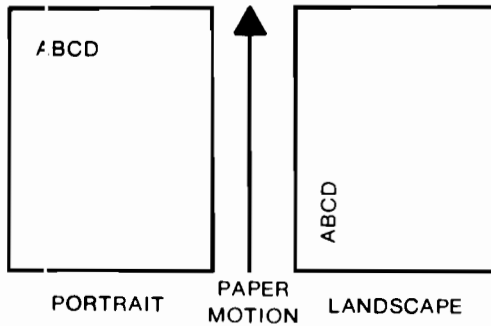

Figure 2-5. Portrait & Landscape Orientation

This escape sequence also causes the top margin, text length, left and right margins, horizontal motion index (HMI), and vertical motion index (VMI) to be defaulted. Therefore, unless you wish to switch orientations, you should not send this escape sequence.

See the "Portrait & Landscape Orientation" discussion later in this chapter (under "MISCELLANEOUS FEATURES") for more information on this sequence.

## DEFAULT FONT CHARACTERISTICS & RESIDENT FONTS

Each of the following discussions of font characteristics specifies the printer default setting for that characteristic. These default settings refer to the default font resident in the printer (font A in the previous example). Some font cartridges, however, can automatically override the printer defaults and instead default to a specific font in the cartridge. **NOTE: Cartridges which override the printer defaults are so marked.**

The LaserJet printer family resident fonts are listed below along with the escape sequences used to select these fonts. Note that the LaserJet printer has 2 resident fonts and the LaserJet<sup>+</sup> and LaserJet 500<sup>+</sup> have 9 resident fonts.

|               | PORTRAIT<br>COURIER<br>(DEFAULT FONT) | LANDSCAPE<br>COURIER | PORTRAIT<br>COMPRESSED<br>LINE PRINTER* |
|---------------|---------------------------------------|----------------------|---|
| ORIENTATION   | <b>PORTRAIT</b>                       | <b>LANDSCAPE</b>     | <b>PORTRAIT</b>                         |
| SYMBOL SET    | <b>ROMAN 8</b>                        | <b>ROMAN 8</b>       | <b>ROMAN 8 *</b>                        |
|               | <b>USASCII *</b>                      | <b>USASCII *</b>     | <b>USASCII *</b>                        |
|               | <b>ROM. EXT. *</b>                    | <b>ROM. EXT. *</b>   | <b>ROM. EXT. *</b>                      |
| SPACING       | <b>FIXED</b>                          | <b>FIXED</b>         | <b>FIXED</b>                            |
| PITCH         | <b>10 CPI</b>                         | <b>10 CPI</b>        | <b>16.66 CPI</b>                        |
| POINT SIZE    | <b>12 POINT</b>                       | <b>12 POINT</b>      | <b>8.5 POINT</b>                        |
| STYLE         | <b>UPRIGHT</b>                        | <b>UPRIGHT</b>       | <b>UPRIGHT</b>                          |
| STROKE_WEIGHT | <b>MEDIUM</b>                         | <b>MEDIUM</b>        | <b>MEDIUM</b>                           |
| TYPE FACE     | <b>COURIER</b>                        | <b>COURIER</b>       | <b>LINE PRINTER</b>                     |

\* The seven resident fonts using these symbol sets are only supplied standard with the LaserJet<sup>+</sup> and LaserJet 500<sup>+</sup> printers.

The following escape sequences are used to select the printer's resident fonts:

Portrait Courier Fonts –  $\text{E}_c\&10\text{E}_c(\_ \text{E}_c(\text{s}0\text{p}10\text{h}12\text{v}0\text{s}0\text{b}3\text{T} **$

|              |               |
|--------------|---------------|
| * Insert ONE | 8U = Roman-8  |
| of these     | 0U = USASCII  |
|              | 0E = RomanExt |

Landscape Courier Fonts –  $\text{E}_c\&110\text{E}_c(\_ \text{E}_c(\text{s}0\text{p}10\text{h}12\text{v}0\text{s}0\text{b}3\text{T}$

|              |               |
|--------------|---------------|
| * Insert ONE | 8U = Roman-8  |
| of these     | 0U = USASCII  |
|              | 0E = RomanExt |

Portrait Compressed

Line Printer Fonts –  $\text{E}_c\&100\text{E}_c(\_ \text{E}_c(\text{s}0\text{p}16.66\text{h}8.5\text{v}0\text{s}0\text{b}0\text{T}$

|                 |              |               |
|-----------------|--------------|---------------|
| (LaserJet + and | * Insert ONE | 8U = Roman-8  |
| LaserJet 500+   | of these     | 0U = USASCII  |
| only)           |              | 0E = RomanExt |

\*\* The Portrait, Courier font operates as the printers' resident default font. You may switch from the other fonts to the default font by resetting the printer (enter  $\text{E}_c\text{E}$  or press the HOLD TO RESET key available with the LaserJet+ and LaserJet 500+ printers) as well as by entering the escape sequence listed here.

## SYMBOL SET SELECTION

The LaserJet family printers allow you to select from several 7-bit and 8-bit symbol sets. A symbol set is a set of characters that are mapped to certain locations in memory. Symbol sets differ in the characters contained and in their locations within memory. The resident default font symbol set is Roman-8. The font cartridge you use will specify the symbol set to select in order to use that character font.

The following list contains the common symbol sets and their associated escape sequences (other symbol sets are available):

TABLE 2-3. SYMBOL SETS

| Symbol Set               | Primary  | Secondary |
|--------------------------|----------|-----------|
| <b>8-bit Symbol Sets</b> |          |           |
| Roman-8                  | $E_c(8U$ | $E_c)8U$  |
| Kana-8                   | $E_c(8K$ | $E_c)8K$  |
| Math-8                   | $E_c(8M$ | $E_c)8M$  |
| ANSI-8                   | $E_c(9U$ | $E_c)9U$  |
| <b>7-bit Symbol Sets</b> |          |           |
| USASCII                  | $E_c(0U$ | $E_c)0U$  |
| Line Draw                | $E_c(0B$ | $E_c)0B$  |
| Math Symbols             | $E_c(0A$ | $E_c)0A$  |
| US Legal                 | $E_c(1U$ | $E_c)1U$  |
| Roman Extension          | $E_c(0E$ | $E_c)0E$  |
| ISO Denmark/Norway       | $E_c(0D$ | $E_c)0D$  |
| ISO United Kingdom       | $E_c(1E$ | $E_c)1E$  |
| ISO France               | $E_c(0F$ | $E_c)0F$  |
| ISO German               | $E_c(0G$ | $E_c)0G$  |
| ISO Italy                | $E_c(0I$ | $E_c)0I$  |
| ISO Sweden/Finland       | $E_c(0S$ | $E_c)0S$  |
| ISO Spain                | $E_c(1S$ | $E_c)1S$  |

**NOTE:** In order to print using a specific symbol set, the internal fonts or a loaded font cartridge must contain a font with the specified symbol set.

## BASIC Example:

```
100 REM -----Character Set Selection -----
110 REM -----Roman-8-----
120 LPRINT CHR$(27);"(8U";"Roman-8 primary symbol set"
130 LPRINT CHR$(27);")8U";"Roman-8 secondary symbol set"
140 REM -- Kana-8
150 LPRINT CHR$(27);"(8K";"Kana-8 primary symbol set"
160 LPRINT CHR$(27);")8K";"Kana-8 secondary symbol set"
170 REM -- USASCII
180 LPRINT CHR$(27);"(0U";"USASCII primary symbol set"
190 LPRINT CHR$(27);")0U";"USASCII secondary symbol set"
200 REM -- Line Drawing
210 LPRINT CHR$(27);"(0B";"Line Draw primary symbol set"
220 LPRINT CHR$(27);")0B";"Line Draw secondary symbol set"
230 REM -- Math Symbols
240 LPRINT CHR$(27);"(0A";"Math primary symbol set"
250 LPRINT CHR$(27);")0A";"Math secondary symbol set"
260 LPRINT CHR$(12); :REM --Form Feed--
```

## PROPORTIONAL VS. FIXED SPACING

Proportional or fixed spacing can be designated for both the primary and secondary character fonts using the following escape sequences:

|                                      |           |
|--------------------------------------|-----------|
| Primary font, proportional spacing   | $E_c(s1P$ |
| Primary font, fixed spacing          | $E_c(s0P$ |
| Secondary font, proportional spacing | $E_c)s1P$ |
| Secondary font, fixed spacing        | $E_c)s0P$ |

If proportional spacing is selected, but there is not a proportionally spaced font available on an installed font cartridge, then a fixed pitch font with the current pitch specification will be designated. The spacing of the resident default font is fixed.

**BASIC Example:**

```

100 REM ---Proportional vs Fixed Spacing-----
110 REM --- proportional spacing
120 LPRINT CHR$(27);"(s1P";"PROPORTIONAL spacing"
130 LPRINT "1234567890abcdefghijklmnopqrstuvwxyABCD"
140 REM --- fixed spacing
150 LPRINT CHR$(27);"(s0P";"FIXED spacing"
160 LPRINT "1234567890abcdefghijklmnopqrstuvwxyABCD"
170 LPRINT CHR$(12);:REM -Form Feed--

```

**FONT PITCH SELECTION**

Font pitch can be specified for both the primary and secondary character fonts by using the following escape sequences:

Font pitch, primary font             $E_c(s\#H$

Font pitch, secondary font         $E_c)s\#H$

# = Print pitch

The value field (#) in this escape sequence specifies the pitch size in characters per inch and is valid to two decimal places. The label on each font cartridge lists the font pitch. For example, if you load a font cartridge containing a 10 character-per-inch font, you would send the  $E_c(s10H$  sequence to select the pitch (10 cpi) of the primary font. **NOTE: In order to print in the specified pitch, a font cartridge must be loaded which contains a font with the specified print pitch.**

The font pitch is ignored by the printer if proportional spacing is activated and available in the requested symbol set. If a print pitch is specified that does not exist, the next greater pitch will be designated. If no greater value exists, the printer will use the next lesser value. **NOTE: 16.66 pitch is greater than 12 pitch and less than 18 pitch.** The pitch of the resident default font is 10 characters per inch.



## BASIC Example:

```
100 REM ---Font Pitch Selection-----
110 REM -- 10 cpi pitch selection -----
120 LPRINT CHR$(27);"(s10H";"10 characters/inch"
130 REM -- 16.66 cpi pitch selection -----
140 LPRINT CHR$(27);"(s16.66H";"16.66 characters/inch"
150 LPRINT CHR$(12); :REM --Form Feed--
```

## FONT PITCH SELECTION: ALTERNATE METHOD

Another way to select print pitch is by using the  $E_c&k\#S$  escape sequence, where the value field (#) selects standard (10 cpi), or compressed (16.66 cpi) print pitch for both the primary and secondary character fonts as shown following:

$E_c&k0S$  Selects standard print pitch

$E_c&k2S$  Selects compressed print pitch

For example, if you load a font cartridge containing a standard pitch font (10 cpi) and a compressed font (16.66 cpi), you would send  $E_c&k2S$  to the printer to specify the compressed font for both primary and secondary character fonts.

**NOTE:** You may override the pitch of a particular font by changing the HMI. See the "Horizontal Cursor Spacing" discussion earlier in this chapter for more information.

## CHARACTER HEIGHT (POINT SIZE) SELECTION

The height of character fonts (character cell size) is specified in points (each point is equal to 1/72 of an inch). The point size can be selected for both the primary and secondary fonts using the following escape sequences:

Primary font height (in points)  $E_c(s\#V$

Secondary font height (in points)  $E_c)s\#V$

# = Point size

The value field (#) specifies the point size of the character font. This value is valid to two decimal places and is indicated on the font cartridge. To select a 14 point font, the  $E_c(s14V$  sequence would be sent to the printer.

**NOTE:** A font with the specified point size must be loaded in the printer in order to print in the specified point size. If the requested point size is not available, the font with the closest point size will be selected. The point size of the resident default font is 12.

#### **BASIC Example:**

```
100 REM --Character Height (Point Size) Selection--
110 REM --- select 10 point character size-----
120 LPRINT CHR$(27);"(s10V";"10 point"
130 REM --- select 12 point character size-----
140 LPRINT CHR$(27);"(s12V";"12 point"
150 LPRINT CHR$(12); :REM --Form Feed--
```

### **CHARACTER STYLE (ITALIC/UPRIGHT)**

Character style (italics or upright) can be selected for both the primary and secondary fonts using one of the following escape sequences:

|                         |           |
|-------------------------|-----------|
| Italics, primary font   | $E_c(s1S$ |
| Upright, primary font   | $E_c(s0S$ |
| Italics, secondary font | $E_c)s1S$ |
| Upright, secondary font | $E_c)s0S$ |

If the requested style is not present, this characteristic is ignored during font designation. The style of the resident default character font is upright. **NOTE:** To print italics, a font cartridge containing an italic font must be loaded into the printer.

## BASIC Example:

```
100 REM --Character Style (Italic/Upright)---
110 REM -- upright -----
120 LPRINT CHR$(27);"(s0S";"Most printing is in upright style"
130 LPRINT "because it is easy to read."
140 REM -----italic-----
150 LPRINT CHR$(27);"(s1S";"Italics are used to highlight"
160 LPRINT "words or phrases."
170 LPRINT CHR$(12);:REM --Form Feed--
```

## STROKE WEIGHT

Stroke weight can be selected for the primary and secondary fonts using the following escape sequences:

Primary font stroke weight     $E_c(s\#B$

Secondary font stroke weight    $E_c)s\#B$

# = Stroke weight

The value field (#) in this escape sequence specifies the stroke weight. The following table lists the value numbers for the different stroke weights:

|        |          |
|--------|----------|
| Light  | -1 to -7 |
| Medium | 0        |
| Bold   | 1 to 7   |

For example, to select a **bold** stroke weight for a secondary character font (with a stroke weight of 4), the  $E_c)s4B$  sequence would be sent to the printer. The standard bold font has a stroke weight of 3. The standard light font has a stroke weight of -3. The stroke weight of the resident default font is medium (0). (If no bold or light stroke weight matches that specified, the most similar font will be selected.) **NOTE: In order to print with a font of a specific stroke weight, that font must be contained in a font cartridge that is loaded in the printer. For example, to run**

the following BASIC example, which selects light, medium, and bold stroke weight, a font cartridge with a bold font and light font would have to be loaded in the printer (the printer already contains a font of medium stroke weight).

#### BASIC Example:

```
100 REM ----- stroke weight -----
110 REM - light weight -----
120 LPRINT CHR$(27);"(s-3B";"January has 31 days."
130 REM - medium weight -----
140 LPRINT CHR$(27);"(s0B";"January has 31 days."
150 REM - Bold -----
160 LPRINT CHR$(27);"(s3B";"January has 31 days."
170 LPRINT CHR$(12);:REM -Form Feed-
```

## TYPEFACE SELECTION

To select a typeface for the primary and secondary fonts, use the following escape sequences:

Primary font typeface     $E_c(s\#T$

Secondary font typeface     $E_c)s\#T$

# = Typeface value number (table on next page)

The value field (#) specifies the typeface to be selected. Table 2-4 on the next page lists value numbers for several typefaces:

To select Elite as the primary font typeface, for example, the  $E_c(s2T$  sequence would be sent to the printer.

If the requested typeface is not available (on a loaded font cartridge), this characteristic is ignored during font designation. The typeface of the resident default font is Courier.

TABLE 2-4. TYPEFACE VALUE NUMBERS

| <u>Value (#)</u> | <u>Typeface</u> |
|------------------|-----------------|
| 0                | Line Printer    |
| 1                | Pica            |
| 2                | Elite           |
| 3                | Courier         |
| 4                | Helv            |
| 5                | Tms Rmn         |
| 6                | Gothic          |
| 7                | Script          |
| 8                | Prestige        |
| 9                | Caslon          |
| 10               | Orator          |

\* Note that this list contains some typefaces which may not be available at this time. Consult your HP Dealer or HP Sales and Service Office for availability information.

### EXAMPLE: SELECTING A CHARACTER FONT

This example illustrates how to select a primary font with the following characteristics:

Orientation—**portrait**  
 Symbol set—**USASCII**  
 Spacing—**fixed**  
 Pitch—**10 characters/inch**  
 Character height—**12 point**  
 Style—**italics**  
 Stroke weight—**light**  
 Typeface—**Courier**

The following escape sequence would be sent to the printer to select a *primary* font with these characteristics:

```
E_c&100E_c(0UE_r(s0PE_c(s10HE_c(s12VE_c(s1SE_c(s-3BE_c(s3T
```

**NOTE:** The previous sequence can be shortened by combining sequences that have the same two characters following the  $E_C$  character and by eliminating unnecessary zeroes:

$E_C \& IO E_C (U E_C (sp10h12v1s-3b3T$

Once you have selected the font as explained above, selecting a font with similar characteristics only requires changing the characteristics that are different. For example, to specify a font differing only in style (upright) and stroke weight (bold), only the following escape sequence would be required:

$E_C (s0S E_C (s3B$

or

shortened sequence:  $E_C (ss3B$

Note that after a font has been selected, the printer "remembers" what was last specified. When selecting a new font, the printer compares the specified characteristics with those last specified, not with those of the font last selected. For example, if you specify an italic font and an upright font is selected (because, for example, no italic font was available), the printer stores the style last specified (italic). Therefore, when you wish to specify another font, if you do not wish to select an italic font, you must specify the upright style.

## **SWITCHING BETWEEN PRIMARY AND SECONDARY CHARACTER FONTS**

Once you have specified your primary and secondary fonts as explained above, you may switch between them using the Shift Out ( $S_0$ ) and Shift In ( $S_1$ ) control codes. A Shift Out selects the secondary font and a Shift In selects the primary font.

# Raster Graphics

Graphics can be printed on any LaserJet family printer by sending raster files containing graphics information to the printer. You can print multiple blocks of data (more than one picture) on each page as long as you do not exceed the graphics data limit (59 Kbytes/page). (NOTE: LaserJet<sup>+</sup> and LaserJet 500<sup>+</sup> printers have expanded user memory (395 Kbytes) which allows more graphics data to be printed per page.)

Each raster line has about 10 bytes of overhead associated with it. This overhead is relatively small for raster lines of 100 bytes or more, but becomes more dominant for very short raster lines. If text and graphics are mixed, the graphics data limit is reduced by approximately four bytes for each character printed.

---

## NOTE

The raster motion is perpendicular to the paper's motion through the printer. **Portrait mode is recommended for printing simple raster graphics applications.** To print raster graphics in the landscape mode, you must first move the cursor to the right (at least the length of the graphics) using the horizontal cursor positioning escape sequences. Otherwise, the printer will attempt to print your graphics in the unprintable region and your data will be lost.

Some programming languages periodically insert Carriage Return and Line Feed commands into the data, causing blank lines in the graphics pattern. These automatic CR and LF commands should be disabled. (For example, the command `WIDTH "LPT1:",255` is used with IBM BASIC, version 3.0 to disable the automatic insertion of CR and LF commands. The command `WIDTH LPRINT 255` performs the same function with BASIC on the HP 150. Consult your programming manual under the WIDTH command for information on disabling these commands using your programming language.)

---

To send raster graphics data to the printer, the following four escape sequences are used. The four sequences should be sent to the printer *in the order shown here*:

- 1) Raster graphics resolution
- 2) Start raster graphics
- 3) Transfer raster graphics
- 4) End raster graphics

The start, transfer, and end raster graphics commands must be sent with *every* block of graphics data you send to the printer. The raster graphics resolution command need only be sent when you wish to change the resolution.

## RASTER GRAPHICS RESOLUTION

All LaserJet family printers have the capability of printing graphics at variable resolution: 300, 150, 100, and 75 dots per inch (DPI). The following escape sequence sets the resolution at which the following graphics data will be printed:

$\text{E}_c^*t\#R$

# = Resolution (75, 100, 150, or 300 dpi)

The value field (#) specifies the resolution (75, 100, 150, or 300) in dots per inch. For example, to set the resolution to 300 dots per inch, the  $\text{E}_c^*t300R$  sequence would be sent to the printer.

The default resolution is 75 dots per inch. This command should be sent before the start graphics command. Once the start graphics command is received by the printer, the  $\text{E}_c^*t\#R$  command is ignored until the end graphics command is received.

Since the LaserJet printer graphics memory limit is 59 Kbytes/page, the size of the raster image is limited by the resolution used. **NOTE: 59 Kb is valid for typical pictures. However, attempting to print several independent vertical lines can significantly reduce the total raster image size.** The following table lists the approximate maximum raster image size (in square inches) for each resolution (for all LaserJet family printers):



TABLE 2-5. MAXIMUM RASTER IMAGE SIZE

| RESOLUTION<br>(dots/inch) | MAXIMUM RASTER<br>IMAGE (square in.) |                             |
|---------------------------|--------------------------------------|-----------------------------|
|                           | LASERJET/<br>LASERJET 500+           | LASERJET+/<br>LASERJET 500+ |
| 75                        | 85.9                                 | full page                   |
| 100                       | 48.3                                 | full page                   |
| 150                       | 21.5                                 | full page                   |
| 300                       | 5.4                                  | 30 - 32                     |

**NOTE**

Changing the resolution also changes the size of the printed raster image. At 300 dots/inch, each "1" sent to the printer represents one dot; at lower resolution, however, each "1" represents a number of dots. **NOTE: Data is transferred to the printer as either a "1" (dot) or "0" (no dot).** For example, using 100 dots/inch resolution, each "1" sent to the printer causes 9 dots to be printed. This is because the printer always prints a 300 x 300 (90,000) dot/square inch image. In order to print at 100 dot/inch resolution (10,000 dots/square inch), the printer forms a "dot" from 9 dots ( $90,000/10,000 = 9$ ). Therefore, your image printed using 100 dots/inch resolution will be 9 times larger than the same image printed using 300 dots/inch. Likewise, the same image will be 4 times larger (than the 300 dpi image) using 150 dot/inch resolution, and 16 times larger using 75 dot/inch resolution.

1 = .

300 dpi

••

150 dpi

•••  
•••  
•••

100 dpi

••••  
••••  
••••  
••••

75 dpi

## START RASTER GRAPHICS

The following escape sequence notifies the printer that raster graphics will follow and also specifies the starting position:

$\text{E}_c^*r\#A$

$\# = 0$  or  $1$

The value field ( $\# = 0$  or  $1$ ) specifies the starting position. A value field of zero specifies that the graphics should be started at the left-most printable position on the page (not the left margin).

A value field of one specifies that the starting position is the current cursor position and the left graphics margin is set to the current  $x$  (horizontal) position. Before you send this command, you may move the cursor (currently active printing position) using the cursor-positioning escape sequences. Then, when you start printing, the upper left corner of the graphics image will be printed where you moved the cursor. **NOTE: When printing graphics in the landscape mode, the "left" graphics margin becomes the margin at the top of the page.**

Once the start raster graphics command is received by the printer, the graphics resolution and left graphics margin are fixed (until the end raster graphics command is received).

## TRANSFER RASTER GRAPHICS

The following escape sequence prepares the printer to receive a specific number of bytes of data and transfers the graphics data to the printer:

$\text{E}_c^*b\#W[\text{raster data}]$

$\# =$  Number of bytes in this line of data

**NOTE: The brackets in the above escape sequence are used for clarity. Do not include the brackets when sending the escape sequence to the printer.**

The value field (#) indicates the number of bytes of binary data to be sent to the printer. These bytes are interpreted as one line of raster graphics data (one dot row). The data should immediately follow W, the terminating character of the escape sequence. **NOTE: A transfer raster graphics sequence must be sent to the printer for each line (dot row) of graphics data.**

The bits of raster graphics data (1's and 0's) sent to the printer describe single dots to be printed on the page. The most significant bit (bit 7) of the first byte of data corresponds to the first pixel within that line. A one indicates that the dot is to be printed, and a zero indicates that the dot should not be printed.

When this escape sequence is executed, the current active cursor position is at the beginning of the next raster line at the left graphics margin. Each dot of the raster data is expanded according to the specified resolution. Graphics is independent of the text margins and perforation skip mode—it ignores these boundaries. Graphics is only limited by the printable area and the page length.

## **END RASTER GRAPHICS**

The following escape sequence informs the printer that all raster graphics data has been transferred to the printer:

**$E_C^*rB$**

After this sequence is sent to the printer, you can then send text to merge with your graphics.



## BASIC PROGRAM TO PRINT ARROW

```
10 REM ***BASIC PROGRAM TO PRINT AN ARROW***
20 REM
30 REM
40 WIDTH "LPT1:" 255 :REM **DISABLE AUTO CR-LF**
50 OPEN "LPT1:" AS #1 :REM **OPEN PRINTER AS A FILE**
60 PRINT #1,CHR$(27);"E"; :REM **RESET PRINTER**
70 PRINT #1,CHR$(27);"t75R"; :REM **SET RESOLUTION**
80 PRINT #1,CHR$(27);"&a40C"; :REM **MOVE CURSOR TO COLUMN 40**
90 PRINT #1,CHR$(27);"r1A"; :REM **START RASTER GRAPHICS**
100 REM
110 REM **BEGIN LOOP TO READ DATA AND PRINT GRAPHICS**
120 FOR J = 1 TO 32
130 READ A,B,C,D :REM **EACH RASTER ROW HAS FOUR BYTES**
140 PRINT #1,CHR$(27);"b4W";CHR$(A);CHR$(B);CHR$(C);CHR$(D);
150 NEXT J
160 REM
170 REM
180 PRINT #1,CHR$(27);"rB"; :REM **END RASTER GRAPHICS**
190 PRINT #1,CHR$(27);"E"; :REM **RESET PRINTER & EJECT PAGE**
200 CLOSE
210 REM
220 REM **THIS IS THE DATA FOR THE ARROW**
230 DATA 0, 0,1,3, 0
240 DATA 0, 0,1,2, 0
250 DATA 0, 0,2,4, 0
260 DATA 0, 0,2,0, 0
270 DATA 0, 0,2,8, 0
280 DATA 0, 0,2,2, 0
290 DATA 0, 0,2,4, 0
300 DATA 0, 0,2,5, 0
310 DATA 0, 0,2,5,128
320 DATA 255,255,255,192
330 DATA 255,255,255,224
340 DATA 255,255,255,240
350 DATA 255,255,255,248
360 DATA 255,255,255,252
370 DATA 255,255,255,254
380 DATA 255,255,255,255
390 DATA 255,255,255,255
400 DATA 255,255,255,254
410 DATA 255,255,255,252
```

420 DATA 255,255,255,248  
430 DATA 255,255,255,240  
440 DATA 255,255,255,224  
450 DATA 255,255,255,192  
460 DATA 0, 0,255,128  
470 DATA 0, 0,255, 0  
480 DATA 0, 0,254, 0  
490 DATA 0, 0,252, 0  
500 DATA 0, 0,248, 0  
510 DATA 0, 0,240, 0  
520 DATA 0, 0,224, 0  
530 DATA 0, 0,192, 0  
540 DATA 0, 0,128, 0

## Miscellaneous Features

### DISPLAY FUNCTIONS

The following two escape sequences are used to enter and exit the display functions mode:

Enter display functions mode  $\text{E}_c\text{Y}$

Exit display functions mode  $\text{E}_c\text{Z}$

When in the display functions mode, all control codes and escape sequences are printed as blanks (and not executed) with the following exceptions:

- **CR** – Carriage Return is executed as a Carriage Return and Line Feed
- $\text{E}_c\text{Z}$  – This escape sequence is printed as a "blank" followed by a **Z**; then the printer exits display functions mode.

The default state is display functions mode off.

## TRANSPARENT PRINT DATA

The following escape sequence allows you to send data to the printer without the printer performing any escape sequences or control codes (even CR and  $\text{E}_c\text{Z}$ ):

$\text{E}_c\&p\#X[\text{transparent print data}]$

# = Number of bytes of print data

The value field (#) specifies the number of bytes of print data that will follow. The print data should follow immediately after the X.

## PERFORATION SKIP MODE

The perforation skip mode controls the bottom margin. If perforation skip mode is OFF, the bottom margin is disabled; if the perforation skip mode is ON, the cursor position skips to the next top margin when the bottom margin is entered. The following escape sequences control the automatic perforation skip mode:

Perforation skip mode ON  $\text{E}_c\&11\text{L}$

Perforation skip mode OFF  $\text{E}_c\&10\text{L}$

The perforation region is defined as the area outside the text area but within the page. If the perforation skip mode is on (default) and a Line Feed or Half Line Feed causes the current active position to enter the perforation region, the current page will be ejected from the printer. **NOTE: If you print in the perforation skip region, the unprintable region may be entered. Attempting to print in the unprintable region results in data loss.**

## CHARACTER OVERSTRIKE

With any **LaserJet** family printer, you may print more than one character over another (overstrike) for the purpose of creating special characters. The printer can print several layers of characters on top of each other. To overstrike characters, back up over the characters and overstrike, or reposition the cursor (using negative horizontal cursor moves) and overstrike. For example, to print "H" on top of "A" you would type the following: A<sup>Esc</sup>&a-1CH . (The escape sequence <sup>Esc</sup>&a-1C moves the cursor back one character.)

## AUTOMATIC UNDERLINING

The **LaserJet** family printers can underline any line or a portion of any line by using the following escape sequences:

Enable underlining: <sup>Esc</sup>&dD

Disable underlining: <sup>Esc</sup>&d@

Once automatic underlining is enabled, all succeeding characters will be underlined until the <sup>Esc</sup>&d@ sequence is sent.

As an example, to underline the word hello, you would send the following:

underline the word <sup>Esc</sup>&dDhello<sup>Esc</sup>&d@

### BASIC Example:

```
100 LPRINT "UNDERLINE THE WORD ";
110 LPRINT CHR$(27);"&dD";"HELLO";CHR$(27);"&d@"
120 LPRINT CHR$(12); :REM -Form Feed-
```



## HALF LINE FEED

The half line feed sequence advances the current active printing position to the same character on the next half line (as defined by the current line spacing). Use the following escape sequence to perform a half line feed:

$$E_C =$$

A negative half line feed may be executed by sending a cursor positioning command --  $E_C\&a-.5R$  .

### BASIC Example:

```
100 REM ----- Normal Line Feed -----
110 LPRINT "Normal Line Feed ";CHR$(10);
120 LPRINT "Normal Line Feed ";CHR$(10);
130 LPRINT "Normal Line Feed ";CHR$(10);
140 REM ----- Half Line Feed -----
150 LPRINT "Half Line Feed ";CHR$(27);"=";
160 LPRINT "Half Line Feed ";CHR$(27);"=";
170 LPRINT "Half Line Feed ";CHR$(27);"=";
190 LPRINT CHR$(12);REM --Form Feed--
```

## LINE TERMINATION

The following escape sequence controls the manner in which the printer interprets line termination characters:

$$E_C\&k\#G$$

The value field (#) specifies which of the following modes will be used (the default mode is zero):

| # | *Definition                           |
|---|---------------------------------------|
| 0 | CR => CR; LF => LF; FF => FF          |
| 1 | CR => CR+LF; LF => LF; FF => FF       |
| 2 | CR => CR; LF => CR+LF; FF => CR+FF    |
| 3 | CR => CR+LF; LF => CR+LF; FF => CR+FF |

\* CR = Carriage Return; LF = Line Feed; FF = Form Feed

## END-OF-LINE WRAP

The following escape sequences allow you to control automatic end-of-line wrap-around:

Enable wrap-around mode     `Esc&s0C`

Disable wrap-around mode    `Esc&s1C`

When the wrap-around mode is enabled, the receipt of a character which would ordinarily appear outside the right margin causes a Carriage Return and Line Feed to be executed. The default is automatic wrap-around disabled.

## PORTRAIT & LANDSCAPE ORIENTATION

The printer can print from left-to-right across the width of the paper (portrait mode--default) or across the length of the paper (landscape mode). Use the following escape sequences to select print orientation (this escape sequence is also discussed in the "Selecting Character Fonts" section of this manual because the orientation affects the font selection process):

Select portrait mode     `Esc&l0O`

Select landscape mode    `Esc&l1O`

Switching print orientations causes the top margin, text length, left margin, right margin, HMI and VMI to be defaulted and the font orientation to be changed appropriately. When the orientation is changed, the primary and secondary character fonts

are re-evaluated based on the new orientation. *This escape sequence must be sent at the beginning of a page.* All data received prior to this command, but after the previous Form Feed, will be printed and a Form Feed and Carriage Return will be executed (auto page eject).

#### **BASIC Example:**

```
100 REM --character font orientation -----
110 LPRINT CHR$(27);"&l00";"This is PORTRAIT mode."
120 LPRINT "PORTRAIT mode is usually used for letters"
130 LPRINT CHR$(27);"&l10";"This is LANDSCAPE mode"
140 LPRINT "LANDSCAPE is useful for other applications"
150 LPRINT CHR$(12);:REM --Form Feed--
```

### **SELECT NUMBER OF COPIES**

The  $\text{F}_c\&l\#X$  escape sequence selects the number of copies of each page to be printed, with the value field (#) specifying the number of copies (1 to 99). This command can be received anywhere within a page (affecting the current page).

### **PAPER INPUT CONTROL**

The following escape sequence allows you to control the method of paper input to your LaserJet or LaserJet + printer (see Chapter IV for LaserJet 500+ paper input control):

$\text{F}_c\&l\#H$

The value field (#) specifies the paper input method as shown in the following table:

TABLE 2-6. PAPER INPUT CONTROL VALUES

| # | Method  |
|---|---|
| 0 | Eject the current page                                |
| 1 | Feed paper from <b>paper input cassette</b> (default) |
| 2 | Feed from manual feed slot                            |
| 3 | Feed envelope in manual feed slot                     |

When the  $\text{Fc}\&\#H$  escape sequence is received during formatting of a page, the current page formatting is immediately halted and a Carriage Return and Form Feed is executed. The next page will be fed as specified by the  $\text{Fc}\&\#H$  escape sequence. This command remains effective until another tray is selected.

When feeding paper from the manual feed slot, the indicator on the **MANUAL FEED** key illuminates and the appropriate paper size alternately flashes on the **status display** (L=letter, LL=legal, A4=A4, and b5=B5) with the **PF** request. Note, however, that the **PF** request does not show up on the display until a page is ready to be ejected (the page is full or a form feed is sent).

When an envelope feed is requested, **PE** flashes on the display—indicating that an envelope should be fed into the printer.

## Specialized Printer Control

Performing a printer reset using the  $\text{Fc}E$  command causes the printer to print any partial pages of data which have been received and resets all programmable features to their default values. This feature is useful in separating one application from another.

Following a reset, the printer remains on-line and no data is lost. This escape sequence has no effect on the interface and causes no disruption in computer-to-peripheral communication.

When a reset is sent to the printer or the printer is powered-on, the starting cursor position is determined using the current top margin and left margin settings (those settings in effect when the first print data is received or when a command affecting the current active printing position is received). Following reset, there are 60 printable lines (10 inches at 6 lines/inch).

After receiving an `ESC`, if a page length, orientation, top margin, left margin, VMI or line spacing command is received before any printable data or commands affecting the current active position is received, the starting cursor position is fixed and the current active position is not affected by successive changes to the top margin, left margin, VMI or line spacing. Once the starting cursor position is fixed, changes to page length or orientation cause a Form Feed and a Carriage Return to be executed. Space characters, Carriage Return, and Horizontal Moves do not cause the starting cursor position to be fixed (that is, if only these commands are received at the beginning of a page, an `ESC` will not cause the page to be ejected).

---

|             |
|-------------|
| <b>NOTE</b> |
|-------------|

If the printer is in manual feed mode and an `ESC` is sent to the printer, the reset will not cause the MANUAL FEED light to turn off until the printer is ready to feed paper from the paper cassette.

---

The following table lists the *default values* of the printer features.

TABLE 2-7. DEFAULT VALUES

- **Underlining**

Automatic underlining--Off

- **Character sets \***

Portrait or landscape orientation--Portrait

Primary symbol set--Roman-8

Secondary symbol set--Roman-8

Primary font pitch--10 characters per inch

Secondary font pitch--10 characters per inch

Primary font height--12 point

Secondary font height--12 point

Primary font style--Upright

Secondary font style--Upright

Primary font stroke weight--Medium

Secondary font stroke weight--Medium

Primary font typeface--Courier

Secondary font typeface--Courier

\* These are default characteristics of the resident default font. If a font cartridge which contains a default font is installed, the font cartridge default will override the resident font default (for both primary and secondary fonts). (*Those cartridges that contain a default font indicate this on the cartridge.*)

- **Page Length, Top Margin, and Text Length**

Page length (size)--Length of installed paper (letter size if no paper installed)

Top margin--Top of page - .5 inches (3 lines at 6 LPI)

Text length--(Page length - top margin) - .5 inches  
(60 lines at 6 LPI using letter-size paper)

- **Side Margins**

Left margin--Column 0

Right margin--Rightmost printable limit

- **Vertical Line Spacing**

Vertical line spacing--6 lines per inch

- **Raster Graphics**

Raster graphics resolution--75 dots/inch

- **Horizontal Cursor Spacing (HMI)**

Horizontal Motion Index (HMI)--12/120

- **Display Functions**

Display functions mode--OFF

- **Perforation Skip Mode**

Perforation skip mode--Enabled

- **Miscellaneous Features**

Line termination--CR=>CR; LF=>LF; FF=>FF

End-of-line wrap--Disabled

Portrait or landscape orientation--Portrait

Select number of copies--One

Paper input control--Feed from **paper input cassette** (or upper cassette for **LaserJet 500+**)

## **SELF-TEST**

Sending the  $\text{Esc}$  escape sequence causes an *interface* self-test to be performed (the printer has a built-in interface). When the command is received by the printer, the printer stops processing data and prints the current page (a Carriage Return and Form Feed are executed). Immediately following this, the self-test is performed without data loss. If no error is detected in the self-test, the printer will remain on-line, ready to print a new page. If an error is detected, the printer is automatically set off-line. For information on self-test errors, see the "Correcting Self-Test Errors" discussion in Chapter V of the **LaserJet Printer Operator's Manual**.





---

## Chapter III

---

---

# LASERJET+ /LASERJET 500+

---

## ADDITIONAL

---

## PRINTER FEATURES

---

### Introduction

This chapter describes the features which are specific to the LaserJet+ and LaserJet 500+ printers. Each feature is discussed in detail, beginning with a general overview, followed by a description of the pertinent escape sequences and examples of each type of operation.

All of the features discussed in Chapter II are also supported on the LaserJet+ and LaserJet 500+ printers. (If you have a LaserJet printer, an upgrade kit is available to upgrade to a LaserJet+ printer).

This chapter contains the following information:

|   |      |
|---|------|
| Memory Utilization . . . . .                                | 3-2  |
| Cursor Control (in dots) . . . . .                          | 3-2  |
| Fonts . . . . .   | 3-4  |
| Font Management Escape Sequences . . . . .                  | 3-5  |
| Assigning a Font ID number to a<br>Cartridge Font . . . . . | 3-20 |
| Downloading HP Fonts . . . . .                              | 3-21 |
| Downloading Character Fonts—General Method . . . . .        | 3-26 |

|   |      |
|---|------|
| Macros. . . . .                                 | 3-27 |
| Macro Escape Sequences. . . . .                 | 3-27 |
| Macro Example. . . . .                          | 3-31 |
| Push/Pop Position. . . . .                      | 3-32 |
| Advanced Graphics. . . . .                      | 3-33 |
| Escape Sequences for Advanced Graphics. . . . . | 3-34 |

## Memory Utilization

LaserJet<sup>+</sup> and LaserJet 500<sup>+</sup> printers contain 512 Kb of memory, 395 Kb of which is available to the user. Memory space used depends on the type of application and the way it is implemented. Rules, patterns and underlines utilize 15 bytes each. Character fonts occupy varying amounts of space, depending on the font; the space occupied by HP-supplied RAM fonts is listed with each font disc. (The *minimum* amount of memory utilized by a 7-bit font is 1 Kbyte; for an 8-bit font, the minimum is 2 Kbytes. The following formulas give a close approximation of memory utilization for macros, characters, fonts, and raster graphics:

$$\text{NUMBER OF BYTES PER MACRO} = \left( \frac{(\text{total \# bytes of macro data}) - 1}{250} + 1 \right) 256$$

$$\text{NUMBER OF BYTES PER CHARACTER} = 4.25$$

$$\text{NUMBER OF BYTES PER RASTER LINE} = (\# \text{ of raster data bytes}) + 10 \text{ bytes}$$

$$\text{NUMBER OF BYTES PER FONT} = \frac{\text{NUMBER OF CHARACTERS IN FONT}}{64} \left( \left( \frac{\text{char. width [bytes]} \times \text{char. height [bytes]} - 1}{64} \right) + 1 \right)$$

## Cursor Control (in Dots)

The LaserJet<sup>+</sup> and LaserJet 500<sup>+</sup> printers allow you to position the printer cursor using dots, in addition to the column/row and decipoint movements available with the LaserJet printer. The following escape sequences are used to move the cursor in dot-size increments:

## HORIZONTAL CURSOR POSITIONING (USING DOTS)

The following escape sequence moves the cursor horizontally in 1/300 inch increments (1 move = 1 dot = 1/300 inch). (This escape sequence limits the cursor movement to the printable limits of the page—see Chapter IV of this manual for limits.)

$\text{E}_c^*p\#X$



# = Horizontal position (in dots)

The value field (#) specifies the new horizontal position in dots— a plus (+) or minus (-) sign before the dot value specifies that the position is relative to the current active position (+ moves cursor right; - moves cursor left)—no plus or minus sign indicates that the cursor move is absolute, with the left boundary of the page being position zero.

## VERTICAL CURSOR POSITIONING (USING DOTS)

The following escape sequence moves the current active position to a new vertical position in 1/300 inch increments (1 move = 1 dot = 1/300 inch). (This escape sequence limits the cursor movement to the printable limits of the page.)

$\text{E}_c^*p\#Y$

# = Vertical position (in dots)

The value field (#) specifies the new vertical position in dots— a plus (+) or minus (-) sign before the dot value specifies that the position is relative to the current active position (+ moves cursor downward and - moves cursor upward)—no plus or minus sign indicates that the cursor move is absolute, with the zero position defined as the top margin and the bottom determined by the bottom of the page.

# Fonts

The LaserJet<sup>+</sup> and LaserJet 500<sup>+</sup> printers have several font features in addition to those of the LaserJet printer. These features are:

- The ability to assign a font ID number to fonts (either font cartridge fonts or fonts resident on disc files). This feature is helpful if you frequently select different fonts. Once you have assigned a font ID number to a specific font, you may select that font with a short escape sequence ( $\text{E}_c(\#X)$ ) instead of specifying all of the font characteristics.
- The ability to download character fonts from disc files (up to 32 fonts may be downloaded and up to 16 printed per page).
- The ability to create new character fonts or to create new characters.

You may assign any or all of the available fonts a font ID number which may be used to select the fonts.

Font files, whether or not they were created by HP, may be downloaded to the printer if the correct format is used.

The following discussion will first explain the escape sequences used for font management. Following that, several font management examples are provided. It may be helpful to scan the font management examples to see which font management escape sequences you will need for a particular function. Then you can skip to the explanations of those escape sequences to learn the specifics of each sequence involved.

## FONT MANAGEMENT ESCAPE SEQUENCES

The following escape sequences are used for LaserJet<sup>+</sup> and LaserJet 500<sup>+</sup> font management:

Specify font ID –  $E_c*c\#D$

Specify character code –  $E_c*c\#E$

Font and character control –  $E_c*c\#F$

Designate font as primary –  $E_c(\#X$

Designate font as secondary –  $E_c)\#X$

Primary font default –  $E_c(\#@$

Secondary font default –  $E_c)\#@$

Create font (font descriptor) –  $E_c(s\#W[\text{font descriptor}]$

Download character –  $E_c(s\#W[\text{character descriptor}]$

Each of the above escape sequences is described in more detail below. Following the escape sequence descriptions are examples using the font management escape sequences.

### SPECIFY FONT ID – $E_c*c\#D$

The font ID number is an arbitrary number which you assign the font for identification purposes. The font ID is specified by sending the  $E_c*c\#D$  escape sequence, where # is the font ID number. The default font ID number is zero and font ID numbers may range from 0 to 32767 (however, only 32 fonts may be resident in the printer at one time).

### SPECIFY CHARACTER CODE – $E_c*c\#E$

This escape sequence specifies the decimal ASCII value of the character to be downloaded (for example, for a USASCII "g", the ASCII decimal character code is 103). The default character code is zero and the character code range is from 0 to 255.

## FONT AND CHARACTER CONTROL – E<sub>c</sub>\*c#F

This escape sequence performs one of the following functions on the font with the font ID last specified. The functions are listed in the table below, with the value field (#) determining the function performed. Following the table, each value is explained in more detail.

TABLE 3-1. FONT AND CHARACTER CONTROL

| # | VALUE | CONTROL FUNCTION  |
|---|-------|---|
| 0 |       | Delete all fonts (temporary and permanent)                        |
| 1 |       | Delete all temporary fonts  |
| 2 |       | Delete font (last font ID specified)                              |
| 3 |       | Delete character code (last character code and font ID specified) |
| 4 |       | Make font temporary (last font ID specified)                      |
| 5 |       | Make font permanent (last font ID specified)                      |
| 6 |       | Copy/Assign current font (last font ID specified)                 |

A value field of 0 deletes all fonts (both temporary and permanent) that have been downloaded.

A value field of 1 deletes all temporary downloaded fonts.

A value field of 2 deletes the font specified by the last font ID escape sequence.

A value field of 3 deletes the character specified by the last character code escape sequence (within the font last specified with the font ID escape sequence).

A value field of 4 establishes the font specified by the font ID escape sequence as a temporary font. A reset eliminates temporary fonts.

A value field of 5 establishes the font specified by the font ID escape sequence as a permanent font. Since the printer has no non-volatile memory, switching the power off eliminates even permanent fonts. Permanent fonts, however, are not affected by a reset.

A value field of 6 copies or assigns the current font, giving the current font ID number to this font. These fonts are designated as temporary fonts and are deleted if the cartridge is removed, if the printer power is turned off, or if the printer is reset.

---

|             |
|-------------|
| <b>NOTE</b> |
|-------------|

If a font currently in use is deleted, the page is closed and all pages are printed before deletion occurs. If a font is deleted and is not in use on the current page, all pages except the current page are printed before the font is deleted.

---

### **DESIGNATE FONT AS PRIMARY -- E<sub>c</sub>(#X**

This escape sequence designates a downloaded font (specified by the font ID number given in the value field [#]) as the primary font. If the designated font is present and is the proper orientation, the specified font is designated as primary, and all the *font characteristics* for the primary font are set to those of the designated font. (NOTE: If the font is proportionally spaced, the pitch parameter is not changed.)

## DESIGNATE FONT AS SECONDARY – $E_c$ #X

This escape sequence designates a downloaded font (specified by the font ID number given in the value field [#]) as the secondary font. If the designated font is present and is the proper orientation, the specified font is designated as secondary, and all the *font characteristics* for the secondary font are set to those of the designated font. See the explanation of "Shift Out" and "Shift In" in Chapter II. (NOTE: If the font is proportionally spaced, the pitch parameter is not changed.)

## PRIMARY FONT DEFAULT – $E_c$ (#@

This escape sequence performs different functions depending on what value is placed in the value field (#):

| # Value | Function  |
|---------|---|
| 0 or 1  | Selects the default symbol set as the symbol set for the primary font in the current orientation.   |
| 2       | Selects the current primary symbol set as the symbol set for the primary font in the current orientation. This acts as a select-font command and forces the printer to re-evaluate the available fonts for the font most similar to that specified. |
| 3       | Selects the default font in the current orientation and sets all the primary font characteristics to those of the default font. (NOTE: If the font is proportionally spaced, the pitch parameter is not changed.)                                   |



## SECONDARY FONT DEFAULT – $E_c$ ##@

This escape sequence performs different functions depending on what value is placed in the value field (#):

| # Value | Function   |
|---------|--|
| 0       | Selects the default symbol set as the symbol set for the secondary font in the current orientation.  |
| 1       | Sets the secondary symbol set to that of the default primary font in the current orientation.  |
| 2       | Sets the secondary symbol set to that of the current primary symbol set in the current orientation.  |
| 3       | Selects the default secondary font in the current orientation and sets all the secondary font characteristics to those of the selected font. (NOTE: If the font is proportionally spaced, the pitch parameter is not changed.) |

## CREATE FONT (FONT DESCRIPTOR) – $E_c$ s#W[font descriptor]

This escape sequence is used to create the font descriptor (font header) for the specified font ID. The value field (#) specifies the number of bytes in the font descriptor (this number can be larger than 26). (NOTE: The brackets surrounding "font descriptor" in the escape sequence are used for clarity—the brackets are not actually part of the escape sequence.) If a font with the same font ID number already exists, the previous font will be deleted when a valid create font escape sequence is received. If there is not enough memory to create the font, the font is not created—but an existing font with the same font ID is deleted. The format for the font descriptor is described on the next page.

|    |                     |                    |
|----|---------------------|--------------------|
| 0  | (26)                |                    |
| 2  | (0)                 | FONT TYPE          |
| 4  | (0)                 |                    |
| 6  | BASELINE POSITION   |                    |
| 8  | CELL WIDTH          |                    |
| 10 | CELL HEIGHT         |                    |
| 12 | ORIENTATION         | FIXED/PROPORTIONAL |
| 14 | SYMBOL SET          |                    |
| 16 | PITCH (DEFAULT HMI) |                    |
| 18 | HEIGHT              |                    |
| 20 | 0                   |                    |
| 22 | 0                   | STYLE              |
| 24 | STROKE WEIGHT       | TYPEFACE           |

Figure 3-1. Font Descriptor

Notice that the font descriptor shown above contains 26 bytes of data. Figure 3-2 illustrates some of the font descriptor values. The accompanying list briefly describes the applicable portions of the font descriptor.

**FONT TYPE** – This byte specifies the font as either a 7-bit font or an 8-bit font as shown below.

| Value | Font Type   |
|-------|---|
| 0     | 7-bit (characters 33 through 127 are printable)     |
| 1     | 8-bit (characters 33-127 and 160-255 are printable) |

**BASELINE POSITION** – These two bytes specify the offset distance from the top of the character cell to the baseline. The distance is specified in dots on the logical coordinate system (the value is the same for portrait and landscape orientations). The baseline position must be contained within the character cell (therefore, the value of the baseline position must fall between zero and the cell height minus one).

**CELL WIDTH** – These two bytes specify the width of the character cell in dots (on the logical coordinate system). The legal cell width range is: 1 to 255 dots.

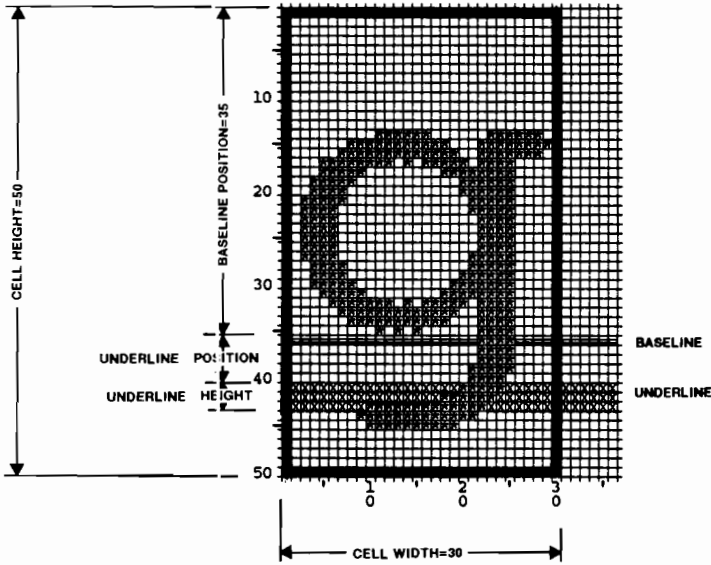

Figure 3-2. Font Descriptor Information

**CELL HEIGHT** – These two bytes specify the height of the character cell in dots (on the logical coordinate system). The legal range is 1 to 255 dots.

**ORIENTATION** – This byte determines the orientation of the font. A value of zero specifies portrait orientation and a value of 1 specifies landscape orientation.

**FIXED/PROPORTIONAL** – This byte specifies whether the font is fixed or proportional. A value of zero specifies fixed spacing and a value of one specifies proportional spacing.

**SYMBOL SET** – These two bytes set up the symbol set to be used for this font. The number is generated by the following formula:

$(\text{Symbol set value field number} \times 32) + (\text{decimal ASCII value for escape sequence terminator}^* - 64)$

\* The escape sequence terminator is the upper-case letter in the value field—for example, U in the 8U value field.

The following table lists the value field numbers for the available **LaserJet** family symbol sets:

TABLE 3-2. SYMBOL SETS

**8-bit Symbol Sets**

| <b>Symbol Set</b> | <b>Value Field Number</b> |
|-------------------|---------------------------|
| Roman-8           | 8U                        |
| Kana-8            | 8K                        |
| Math-8            | 8M                        |

**7-bit Symbol Sets**

|                    |    |
|--------------------|----|
| USASCII            | 0U |
| Line Draw          | 0B |
| Math Symbols       | 0A |
| US Legal           | 1U |
| Roman Extension    | 0E |
| ISO Denmark/Norway | 0D |
| ISO United Kingdom | 1E |
| ISO France         | 0F |
| ISO German         | 0G |
| ISO Italy          | 0I |
| ISO Sweden/Finland | 0S |
| ISO Spain          | 1S |

For example, for the ROMAN-8 symbol set:

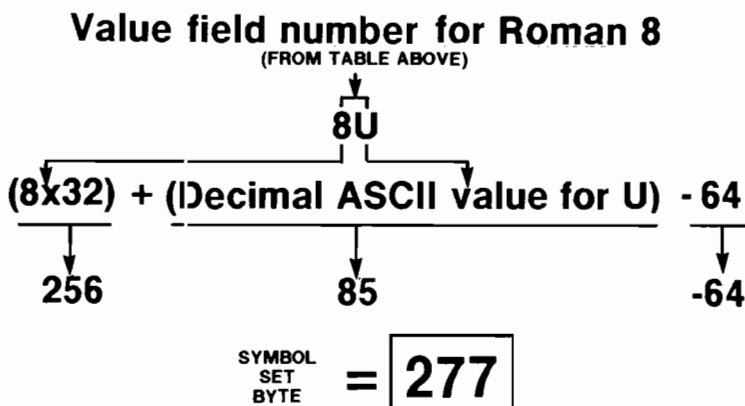

**PITCH** -- These two bytes specify the font's pitch (horizontal distance moved per character) and is expressed in number of dots multiplied by four. For example, if you wanted a 12 pitch font, you would want the printer to move 25 dots per character (300 dots per inch divided by 12 characters per inch = 25 dots/character). To calculate the number required in this part of the font descriptor, you would multiply 25 by 4 and enter 100.

The pitch may be specified to within a quarter of a dot and the valid range of values is 2 to 1260.

**HEIGHT** -- These two bytes specify the height of the font and are expressed in number of dots multiplied by four. For example, to specify a font height of 50 dots, you would multiply 50 by 4 to get a value of 200. This value may be specified to within a quarter of a dot and the valid range of values is 0 to 10922.

**STYLE** -- This byte specifies whether the font is an upright or italic font (0 -- upright; 1 -- italic).

**STROKE WEIGHT** – This byte specifies the lightness or boldness of a font. The stroke weight value may range from -7 to 7 with 0 being the normal stroke weight, negative numbers having lighter stroke weight, and positive numbers having heavier stroke weight. The normal bold stroke weight is 3 and the normal light stroke weight is 3.

**TYPEFACE** – This byte specifies the typeface of the font as shown in the following table:

TABLE 3-3. TYPEFACE VALUES

| Value | Typeface     |
|-------|--------------|
| 0     | Line Printer |
| 1     | Pica         |
| 2     | Elite        |
| 3     | Courier      |
| 4     | Helv         |
| 5     | Tms Rmn      |
| 6     | Gothic       |
| 7     | Script       |
| 8     | Prestige     |
| 9     | Caslon       |
| 10    | Orator       |

## FONT DESCRIPTOR EXAMPLE

This example creates a Courier 12 point font and assigns it a font ID number of zero:

**E<sub>c</sub>\*c0D** -- Set the font ID to 0

**E<sub>c</sub>s26W**[font descriptor--see below] -- Download font descriptor.

The following is the font descriptor block (see Figure 3-1):

Bytes 0 and 1 -- 0 and 26

Byte 2 -- 0

Byte 3 (Font type, 8-bit) -- 1

Bytes 4 and 5 -- 0 and 0

Bytes 6 and 7 (Baseline position) -- 0 and 35

Bytes 8 and 9 (Cell Width) -- 0 and 30

Bytes 10 and 11 (Cell Height) -- 0 and 50

Byte 12 (Orientation, portrait) -- 0

Byte 13 (Spacing, fixed) -- 0

Bytes 14 and 15 (Symbol Set, Roman-8 [8U]) -- 1 and 21

Bytes 16 and 17 (Pitch) -- 0 and 120

Bytes 18 and 19 (Height) -- 0 and 200

Bytes 20 and 21 -- 0 and 0

Byte 22 -- 0

Byte 23 (Style, upright) -- 0

Byte 24 (Stroke weight, normal) -- 0

Byte 25 (Typeface, Courier) -- 3

## DOWNLOAD CHARACTER – $E_c(s\#W[\text{Descriptor and data}])$

This escape sequence is used to download a character to the printer. The downloaded character is assigned the character code last specified and is added to the font specified by the font ID escape sequence. If an existing character has the same character code as the character being downloaded, the existing character is deleted and the new character is downloaded. **NOTE: If there is not enough memory to download a character, the font will be deleted.** The download character escape sequence,  $E_c(s\#W[\text{character descriptor and data}])$ , specifies the number of bytes (#) of character data that will follow the escape sequence (this includes the 16 bytes of data in the descriptor). (NOTE: The brackets surrounding "Descriptor and data" in the download character escape sequence are used for clarity—the brackets are not actually part of the escape sequence.) The format of the character descriptor and data is as follows:

|    |                         |     |
|----|-------------------------|-----|
| 0  | (4)                     | (0) |
| 2  | (14)                    | (1) |
| 4  | <b>ORIENTATION</b>      | (0) |
| 6  | <b>LEFT OFFSET</b>      |     |
| 8  | <b>TOP OFFSET</b>       |     |
| 10 | <b>CHARACTER WIDTH</b>  |     |
| 12 | <b>CHARACTER HEIGHT</b> |     |
| 14 | <b>DELTA X</b>          |     |
| 16 | <b>CHARACTER DATA:</b>  |     |

Figure 3-3. Character Descriptor



The following figures illustrate some of the character descriptor data:

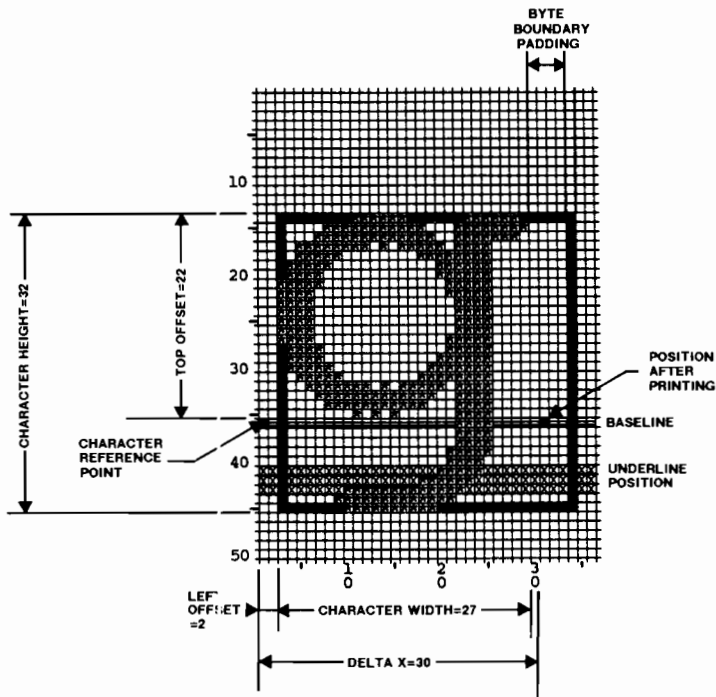

Figure 3-4. Character-Portrait Mode

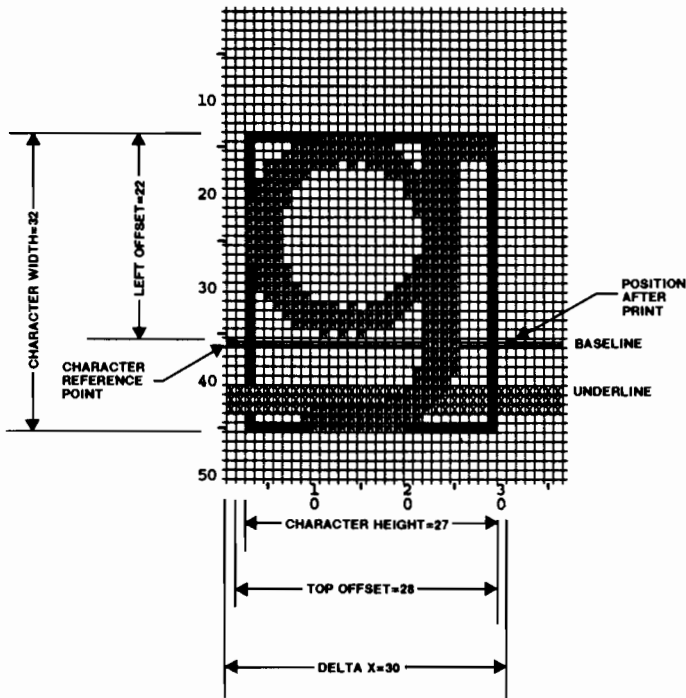

Figure 3-5. Character-Landscape Mode

The following definitions describe the first 16 bytes of character data:

**ORIENTATION** – This byte specifies the character orientation. A value of 0 specifies portrait orientation and a value of 1 specifies landscape orientation.

**LEFT OFFSET** – This value specifies the distance in dots from the reference point to the left side of the character pattern. The offset is relative to the physical page, so the value is different for different orientations. The range of left offset values is -128 to 127.

**TOP OFFSET** – This value specifies the distance in dots from the reference point to the top of the character pattern. The offset is relative to the physical page, so the value is different for different orientations. The range of top offset values is -128 to 127.

**CHARACTER WIDTH** – This value specifies the width of the character in dots. The character width is relative to the physical page, so the value is different for different orientations. The range of values is 0 to 128.

**CHARACTER HEIGHT** – This value specifies the height of the character in dots (0 to 128). The character height is relative to the physical page, so the value is different for portrait and landscape.

**DELTA X** – These two bytes represent the X (horizontal) distance that the cursor travels after printing the specified character. This value is specified in number of dots multiplied by 4. For example, if you wished to move 5 dots after printing the specified character, you would enter a value of 20. The printer does not allow for 1/4 dot moves; all Delta X values should be a multiple of 4. Positive and negative values are treated as zero. The Delta X value is only used for proportionally spaced character fonts.

**CHARACTER DATA** – The remaining bytes are the raw data used to represent a character. The character data is composed of a string of bytes that defines the character. The bytes are grouped in rows, with each row containing enough bytes to describe the character width. A row describes one row of pixels of the character from left to right, parallel to the raster scan. The rows are stacked vertically from top to bottom. Each bit describes one pixel of the character. If the bit is set (1), a pixel is printed. If the bit is clear (0), no pixel is printed. The number of bytes of character data is exactly equal to the character width in bytes times the character height (in pixels).

## **DOWNLOAD CHARACTER EXAMPLE**

The following example downloads character 103 (a lower-case "g") into the font specified as font ID 0:

$\text{E}_c^*c\text{0D}$  – Set the font ID to 0

$\text{E}_c^*c1\text{03E}$  – Set the character code to 103

$\text{E}_c(\text{s}144\text{W}[\text{Descriptor and data}]$  – Download the character into font 0. 144 is the number of character data bytes (128) plus the 16 bytes in the character descriptor.

The following is the character descriptor block for a Courier 12 point "g" in portrait orientation (see figures 3-3 and 3-4):

Byte 0 – 4

Byte 1 – 0

Byte 2 – 14

Byte 3 – 1

Byte 4 (Orientation, portrait) – 0

Byte 5 – 0

Bytes 6 and 7 (Left Offset) – 0 and 2

Bytes 8 and 9 (Top Offset) – 0 and 22

Bytes 10 and 11 (Character Width) – 0 and 27

Bytes 12 and 13 (Character Height) – 0 and 32

Bytes 14 and 15 (Delta X) – 0 and 120

Bytes 16 through 127 – DATA

## ASSIGNING A FONT ID NUMBER TO A FONT CARTRIDGE FONT

You may assign a font ID number to any of your fonts. This is accomplished by performing the following steps:

- a. Specify (as a primary font) the font you wish to assign a font ID number. (Use the font escape sequences explained in Chapter II [orientation, symbol set, pitch, etc.]). Send a Shift In character to ensure that the primary font is selected.
- b. Specify the font ID number using the  $\text{E}_c^*c\#\text{D}$  escape sequence, where # is the number you wish to use to refer to the font. For example, to specify the font as number 4, you would send the escape sequence  $\text{E}_c^*c4\text{D}$  .

- c. Assign the currently specified font (using the last specified font ID number) as a temporary font by sending the following escape sequence to the printer:  $\text{E}_c^*c6F$  . (You may assign the font as a permanent font by sending  $\text{E}_c^*c6f5F$  instead.)

Steps a. through c. assign a font ID number to the desired character font. You may assign font ID numbers to any or all of the fonts accessible to you.

Once you have assigned ID numbers to your fonts, you may print with a font by sending the escape sequence  $\text{E}_c(\#X$ , where # is the font ID number of the font you wish to print.

For example, if you installed the 92286B font cartridge into your printer and wished to assign font ID number 1 to the landscape line printer font, you would send the following escape sequences:

$\text{E}_c\&110$  -- Specifies landscape orientation

$\text{E}_c(8U\text{E}_c(s0p16.66h8.5v0s-1b0T$  -- Specifies line printer font as primary font.

$S_1$  -- Shift In to primary font.

$\text{E}_c^*c1D$  -- Specifies font ID of 1.

$\text{E}_c^*c6F$  -- Assigns current active font as a temporary font.

To print with the font we just specified as font 1, we would send the following escape sequence:

$\text{E}_c(1X$  -- Designates font with font ID of 1 as primary font.

## DOWNLOADING HEWLETT-PACKARD FONTS

Several escape sequences are required to download character fonts to the printer. However, Hewlett-Packard font files have the escape sequences embedded in the font file so that simply assigning a font ID number and copying the file to the printer downloads the font. Downloading a font from a Hewlett-Packard font file is accomplished as follows:

---

|             |
|-------------|
| <b>NOTE</b> |
|-------------|

These fonts are set up as temporary—a reset will erase them from memory. If you wish to make them permanent (unaffected by reset), use the *font and character control* escape sequence ( $\text{^c}^*\text{c}\#\text{F}$ ).

---

- a. Specify the font ID number of the font you wish to download. This is an arbitrary number which you assign the font for identification purposes.
- b. Copy the font file to the printer (for example, you may use the MS-DOS "COPY" command).

The first step, specifying the font ID number, is accomplished by sending the following escape sequence:

$\text{^c}^*\text{c}\#\text{D}$

The value field (#) in this escape sequence specifies the font ID number of the font we wish to download.

The second step, copying the font file to the printer, actually downloads the font.

Normally, the commercially available utility program or software package would manage user fonts. In the absence of these packages, the user can download fonts with the COPY command. BASIC programming language or other tools can be used to set the Font ID and select the font as shown in the following example.

### DOWNLOAD EXAMPLE

This example illustrates how you can set up a batch file (DOWNLOAD.BAT) in MS-DOS for downloading a font to the printer. The batch file first calls up a BASIC program (DOWNLOAD.BAS) to assign a Font ID number to the font to be assigned. Then, the batch file does an MS-DOS COPY of the font

file to the printer. Finally, another BASIC program (PERMTEMP.BAS) is called up to assign the font as permanent and designate the font as a primary font. To create a simple batch file such as this, perform the following steps:

a. Load BASIC and enter the following program:

```
10 PRINT "WHAT FONT ID NUMBER WOULD YOU LIKE"
20 PRINT "TO ASSIGN TO THE DOWNLOADED FONT?"
30 PRINT "(ENTER A NUMBER AND PRESS RETURN)"
40 INPUT FONTID
50 LPRINT CHR$(27);"c";FONTID;"D";
60 SYSTEM
```

---

|             |
|-------------|
| <b>NOTE</b> |
|-------------|

If only one font is to be downloaded, the program used in step a. may be eliminated (also take the "BASIC DOWNLOAD.BAS" statement out of the DOWNLOAD.BAT file in step e.)--the Font ID will default to zero if not specified.

---

b. Save the above program as file "DOWNLOAD.BAS".

c. Enter the following BASIC program and save it as "PERMTEMP.BAS".

```
10 PRINT "WHAT FONT ID NUMBER DID"
20 PRINT "YOU JUST ASSIGN?"
30 PRINT "(TYPE FONT ID NUMBER & PRESS RETURN)"
40 INPUT FONTID
50 LPRINT CHR$(27);"c";FONTID;"D";
60 REM -----MAKE FONT PERMANENT-----
70 LPRINT CHR$(27);"c5F";
80 REM -DESIGNATE FONT AS PRIMARY-
90 LPRINT CHR$(27);"(";FONTID;"X";
100 LPRINT "THIS IS A SAMPLE OF THE FONT";
110 LPRINT "JUST DOWNLOADED"
120 LPRINT CHR$(12);
130 SYSTEM
```

- d. Exit BASIC and load MS-DOS.
- e. Create a batch file called "DOWNLOAD.BAT" by typing the following (the /B in the COPY command *must* be included):

```
COPY CON: DOWNLOAD.BAT  
BASIC DOWNLOAD.BAS  
COPY /B %1 PRN:  
BASIC PERMTEMP.BAS  
CTRL-Z (press CTRL and Z keys at same time and press return)
```

- f. Once the above steps have been performed, fonts are downloaded by typing the following:

**A>DOWNLOAD filename**

For example, to download a bold Courier font (file name—COURBP.CHR) to the printer, you would type **DOWNLOAD COURBP.CHR** from the MS-DOS prompt and press RETURN. (Remember that the font file disc must be loaded and the complete font file name must be entered.)

---

|             |
|-------------|
| <b>NOTE</b> |
|-------------|

The user can customize this process as needed to avoid loading BASIC. To do this, the following changes may be made.

Modify the program in step a. as shown below:

```
10 PRINT "WHAT FONT ID NUMBER WOULD YOU LIKE"  
20 PRINT "TO ASSIGN TO THE DOWNLOADED FONT?"  
30 PRINT "(ENTER A NUMBER AND PRESS RETURN)"  
40 INPUT FONTID  
50 OPEN "O",#1,"CONFIG1"  
60 PRINT #1,CHR$(27);"*c";FONTID;"D";  
70 CLOSE  
80 SYSTEM
```



Then modify the program in step c. as follows:

```
10 PRINT "WHAT FONT ID NUMBER DID"  
20 PRINT "YOU JUST ASSIGN?"  
30 PRINT "(TYPE FONT ID NUMBER & PRESS RETURN)"  
40 INPUT FONID  
50 OPEN "O",#1,"CONFIG2"  
60 PRINT #1,CHR$(27);"*c";FONTID;"D";  
70 REM ——MAKE FONT PERMANENT——  
80 PRINT #1,CHR$(27);"*c5F";  
90 REM —DESIGNATE FONT AS PRIMARY—  
100 PRINT #1,CHR$(27);"(";FONTID;"X";  
110 PRINT #1,"THIS IS A SAMPLE OF THE FONT";  
120 PRINT #1,"JUST DOWNLOADED"  
130 PRINT #1;CHR$(12);  
140 CLOSE  
150 SYSTEM
```

Run both BASIC programs once to build the CONFIG1 and CONFIG2 files. Then create a new DOWNLOAD.BAT file by typing the following (the /B in the COPY command *must* be included):

```
COPY CON: DOWNLOAD.BAT  
COPY CONFIG1 PRN:  
COPY /B %1 PRN:  
COPY CONFIG2 PRN:  
CTRL-Z (Press CTRL and Z at same time; then press Return)
```

With these modifications, the batch file would not have to load BASIC during its execution and no user interaction would be necessary when the font is actually downloaded.

---

## **DOWNLOADING CHARACTER FONTS—GENERAL METHOD**

The process for downloading characters or character fonts is described in the following discussion. When using Hewlett-Packard font files, the downloading process is automatically accomplished by escape sequences that are embedded in the font files—therefore, only copying the file to the printer is required for downloading HP fonts. When using a format other than Hewlett-Packard's font file format, downloading is accomplished as follows:

- a. A font ID number is specified to reference the font to be downloaded.
- b. The font descriptor (font header) is downloaded to the printer.
- c. The character code of the character to be downloaded is specified.
- d. The character descriptor data is downloaded to the printer.

The process just described downloads one character to the printer. To download more than one character (such as a whole font), steps c. and d. would be repeated, only the character code would be changed each time to the character code value of the next character to be downloaded.

After the font is downloaded, the font can be assigned a permanent font status if that is needed. See the "LaserJet+/LaserJet 500+ Font Management" discussion in Chapter IV for suggestions on when to assign permanent font status.

# Macros

A macro is a command (escape sequence) which combines other escape sequences to simplify a given task. The LaserJet<sup>+</sup> and LaserJet 500<sup>+</sup> printers allow you to store up to 32 macros at a time. Macros can be defined as either temporary (default) or permanent; temporary macros are deleted by reset or power-down; permanent macros are deleted when the printer is powered down but are not affected by the  $E_cE$  reset sequence or pressing the RESET key.

One use for a macro is for specifying character fonts. All of the escape sequences necessary to specify a particular font can be stored as a macro; then, when you want to print with that font, you only need to send the escape sequence to execute that macro—instead of sending the whole string of select-font escape sequences (symbol set, pitch, point size, etc.).

## MACRO ESCAPE SEQUENCES

The following list contains the escape sequences used to create and use macros. Following this list is a more detailed description of each escape sequence. Examples which use macros are provided after the escape sequence descriptions.

Macro ID —  $E_c&f\#Y$

Macro control —  $E_c&f\#X$

**MACRO ID** —  $E_c&f\#Y$  — This escape sequence specifies the ID number (#) of the macro you wish to refer to. For example, if you wish to download a macro, you must first use this escape sequence to identify it. Likewise, when you wish to execute a macro, you must first send this escape sequence to identify which macro you wish to execute.

**MACRO CONTROL** —  $E_c&f\#X$  — This escape sequence specifies what macro control function you wish to perform. The number specified in the value field (#) determines what function this escape sequence performs. Table 3-4 describes the function for each value field number:

TABLE 3-4. MACRO CONTROL FUNCTIONS

| # Value | Macro Control Function               |
|---------|--------------------------------------|
| 0       | Start macro definition (macro ID)    |
| 1       | Stop macro definition                |
| 2       | Execute macro (macro ID)             |
| 3       | Call macro (macro ID)                |
| 4       | Enable auto macro overlay (macro ID) |
| 5       | Disable auto macro overlay           |
| 6       | Delete all macros                    |
| 7       | Delete all temporary macros          |
| 8       | Delete macro (macro ID)              |
| 9       | Make macro temporary (macro ID)      |
| 10      | Make macro permanent (macro ID)      |

| Value | Description  |
|-------|--|
| 0,1   | Upon receipt of the start macro definition command ( $E_c\&f0X$ ), a new macro is created, marked as temporary, and is assigned the current macro ID as its identifier. All data (including binary data) is read and is stored as the definition of the specified macro ID until a stop macro definition ( $E_c\&f1X$ ) or a reset is received.  |
| 2     | Upon receipt of the execute macro command ( $E_c\&f2X$ ), the macro specified by macro ID is executed using the <i>current environment</i> . When the macro has been executed, any of the variables in the <i>current environment</i> that have been changed are "remembered" by the printer. The current cursor position, however, is where it was after the macro was executed. The <i>current environment</i> consists of the current state of the variables listed in Table 3-5. |

TABLE 3-5. CURRENT ENVIRONMENT VARIABLES

|                                |                                 |
|--------------------------------|---------------------------------|
| Page length                    | Character code                  |
| Orientation                    | Macro ID                        |
| Input control                  | VMI/line spacing                |
| Copy count                     | Horizontal rule spacing         |
| Margins (top, left, and right) | Vertical rule size              |
| Perf. skip mode                | Underline mode                  |
| Line termination               | Graphics resolution             |
| EOL wrap                       | Graphics mode                   |
| Font attributes                | Graphics left margin            |
| HMI                            | Pattern ID                      |
| Primary font address           | Job offset position (Chapter 4) |
| Font ID                        |                                 |

3 Upon receipt of the call macro command ( $E_c\&f3X$ ), the macro specified by macro ID is executed using the *current environment*. When the macro has been executed, any of the variables in the current environment that have been changed are "forgotten" by the printer—the printer reverts to the state that existed before the macro was called. The current cursor position, however, will remain where it was after the macro was executed. The *current environment* consists of the current state of the variables shown above.

4 Upon receipt of the enable auto macro overlay command ( $E_c\&f4X$ ), the macro specified by macro ID is designated as the macro to use for auto macro overlay on each page. This action replaces any previously activated auto macro overlay.

If a macro is enabled for auto macro overlay, then every time a page is printed, the auto macro overlay is executed using the overlay environment. Upon completion of the macro, the previous current environment is restored, replacing the overlay environment. The overlay environment consists of the current settings of the variables listed in Table 3-6A:

TABLE 3-6A. OVERLAY ENVIRONMENT VARIABLES

|               |                                 |
|---------------|---------------------------------|
| Overlay       | Copy count                      |
| Page length   | Position stack                  |
| Orientation   | Job offset position (Chapter 4) |
| Input control |                                 |

The overlay environment also consists of the default variables listed in Table 3-6B:

TABLE 3-6B. OVERLAY DEFAULT VARIABLES

|   |
|---|
| Top margin (1/2-inch from top of page)        |
| Bottom margin (1/2-inch from bottom of page)  |
| Left margin (left-most printable position)    |
| Right margin (right-most printable position)  |
| Perforation skip mode (on)                    |
| Line termination (0)                          |
| EOL wrap (off)                                |
| Font attributes (default)                     |
| HMI (default)                                 |
| Primary font (default)                        |
| Secondary font (default)                      |
| Font ID (0)                                   |
| Character code (0)                            |
| Macro ID (0)                                  |
| Current active position (left and top margin) |
| VMI/Line spacing (6 lpi)                      |
| Horizontal rule size (0)                      |
| Vertical rule size (0)                        |
| Underline mode (off)                          |
| Graphics resolution (75 dpi)                  |
| Graphics mode (off)                           |
| Pattern ID (0)                                |

- 5            Sending the `Esc&f5X` escape sequence commands the printer to disable auto macro overlay. This command takes effect on the current page.  
 NOTE: Changing the page length or orientation causes the auto macro overlay to be disabled after the command is executed.

- 6            Sending the `^c&f6X` escape sequence deletes all macros, both temporary and permanent, including any automatic macro overlay that may have been in effect.
- 7            Sending the `^c&f7X` escape sequence deletes all temporary macros, including the auto macro overlay if any of the macros used are temporary.
- 8            Sending the `^c&f8X` command deletes the macro last specified by the macro ID escape sequence.
- 9            Sending the `^c&f9X` escape sequence causes the macro specified by the last font ID escape sequence to be made temporary.
- 10          Sending the `^c&f10X` escape sequence causes the macro specified by the last font ID escape sequence to be made permanent.

## MACRO EXAMPLE

The following example shows how to download a sample letterhead macro to the printer.

```

^c&f1Y -- Specify macro ID as 1
^c&f0X -- Start macro definition
^c&a540h360V -- Position for start of logo
^c*t150R -- Set graphics resolution to 150 DPI
^c*r1A -- Start raster image of logo
^c*b60W[raster data] -- Send the first raster line
.
.
^c*b60W[raster data] -- Send the last raster line
^c*rB -- Stop raster graphics
^c&a540h780V -- Position for lettering
ABC INCORPORATED: Post -- Text
Office Box 15, Detroit, Mich. -- Text
48247, Telephone 208 376-6000 -- Text
^c&a540h960V -- Position first rule (black line)
^c*c10v4680H -- Set rule height and width

```

`^c^c0P` -- Print first rule  
`^c&a540h980V` -- Position for second rule  
`^c^c0P` -- Print second rule  
`^c&a1200V^cR` -- Position for first line of text  
`^c&f1X` -- Stop macro definition

To execute the sample letterhead macro, you would send the `^c&f1y2X` escape sequence (the escape sequence specifies macro ID 1 and executes the macro).

## Push/Pop Position

The push/pop position escape sequence (`^c&f#S`) allows you to save and recall (push and pop) the position of the cursor.

### **PUSH/POP POSITION** -- `^c&f#S`

This escape sequence allows you to save the current active cursor position in a position stack and to return to the stored cursor position when desired. Saving the current active cursor position is referred to as pushing, and recalling a cursor position from the stack and moving to that position is called popping. Up to 20 cursor positions may be stored at one time, with the last position pushed always being the first position popped.

The following escape sequences are used to push and pop the cursor position:

`^c&f0S` -- Pushes (stores) the current active cursor position

`^c&f1S` -- Pops (restores) the last pushed cursor position



## PUSH/POP EXAMPLE

`E_c&a100h200V` -- Moves cursor to position 100, 200 (decipoints).

`E_c&f0s` -- Pushes the current cursor position (100,200).

`E_c&f1y3X` -- Specifies and calls macro ID number 1.

`E_c&a200h300V` -- Moves cursor to position 200, 300 (decipoints).

`E_c&f0S` -- Pushes the current cursor position (200,300).

`E_c&a400h500V` -- Moves cursor to position 400, 500 (decipoints).

`E_c&f1S` -- Pops to last position pushed (the current cursor position moves to 200, 300 because that is the last cursor location pushed).

`E_c&f1S` -- Pops to location 100, 200 (the cursor moves to position 100, 200 because it is now the top position on the stack).

## Advanced Graphics

LaserJet<sup>+</sup> and LaserJet 500<sup>+</sup> printers allow you the capability to print rules, patterns, and various shades of gray. (A rule is a solid black rectangle of a specified height and width.)

In general, there are three steps required to print rules, patterns, or gray shading patterns:

- a. Position the cursor in the upper left corner of the graphic pattern to be printed.
- b. Determine the pattern size (in either dots or decipoints) and send both horizontal and vertical rule/pattern size escape sequences to the printer.
- c. Command the printer to print the rule/pattern.

There are several escape sequences that are used to perform these functions. These escape sequences are explained below, followed by examples which use the advanced graphics features.

## ESCAPE SEQUENCES FOR ADVANCED GRAPHICS

### HORIZONTAL RULE/PATTERN SIZE (IN DOTS) – $E_c^*c\#A$

This escape sequence specifies the horizontal size (in number of dots) of the rule or pattern. This size is relative to the rotation of the page (that is, printing the same rule/pattern in both portrait and landscape orientations produces two different images). Power-up and resets cause this value to default to zero. Values greater than the page size are acceptable, but the final image area will be clipped at the boundaries of the printable area of the page.

To specify a horizontal rule/pattern size of 5 inches, for example, you would use a value of 1500 dots (5 inches x 300 dots/inch) using the escape sequence  $E_c^*c1500A$ .

### HORIZONTAL RULE/PATTERN SIZE (IN DECIPOINTS) – $E_c^*c\#H$

This escape sequence is the same as that for specifying horizontal rule/pattern size in dots, only the specified increments are different. One decipoint is equal to 1/720 of an inch. For example, to specify a horizontal rule/pattern size (in decipoints) of 4 inches, you would send the escape sequence  $E_c^*c2880H$ , because 4 inches x 720 decipoints/inch = 2880 decipoints.

If the size is specified in decipoints, the size is converted into dots. If the conversion results in a non-integer number of dots, the number of dots is rounded up to the next integer. Since 2.4 decipoints = 1 dot (720 decipoints/inch x 1 inch/300 dots = 2.4 decipoints/dot), dividing the number of decipoints by 2.4 and rounding up to the next integer gives the number of dots. For example, to convert 1225 decipoints to dots, divide 1225 by 2.4, resulting in 510.4, which would be rounded up to 511 dots.

## VERTICAL RULE/PATTERN SIZE (IN DOTS) -- $\text{E}_c^*c\#B$

This escape sequence specifies the vertical size (in dots) of the rule or pattern. This size is relative to the rotation of the page (that is, printing the same rule/pattern in both portrait and landscape orientations produces two different images). Power-up and resets cause this value to default to zero. Values greater than the page size are acceptable, but the final image area will be clipped at the boundaries of the printable area of the page.

To specify a vertical rule/pattern size of 3 inches, for example, you would use a value of 900 dots (3 inches x 300 dots/inch) using the escape sequence  $\text{E}_c^*c900B$ .

## VERTICAL RULE/PATTERN SIZE (IN DECIPOINTS) -- $\text{E}_c^*c\#V$

This escape sequence is the same as specifying the vertical rule/pattern size in dots, only the value increments are different. One decipoint equals 1/720 of an inch. For example, to specify a vertical rule/pattern size of 2 inches, you would send  $\text{E}_c^*c1440V$ , because 2 inches x 720 decipoints per inch = 1440 decipoints.

## PATTERN ID -- $\text{E}_c^*c\#G$

This escape sequence is used in combination with the print rule/pattern escape sequence and specifies which pattern is to be used when the print rule/pattern escape sequence is issued. To specify an HP-defined pattern, specify the pattern number (1 through 6-- see figure 3-7) in the escape sequence value field (#). To specify a gray scale pattern, specify any value between 1 and 100 in the value field. For example, if you wanted to print shading with a 50% gray scale pattern, you would send the  $\text{E}_c^*c50G$  escape sequence to the printer. This sequence, in combination with the print rule/pattern escape sequence, would print a 50% gray scale pattern in the specified area. The following HP-defined patterns and gray scale shading patterns are available (figures 3-6 and 3-7):

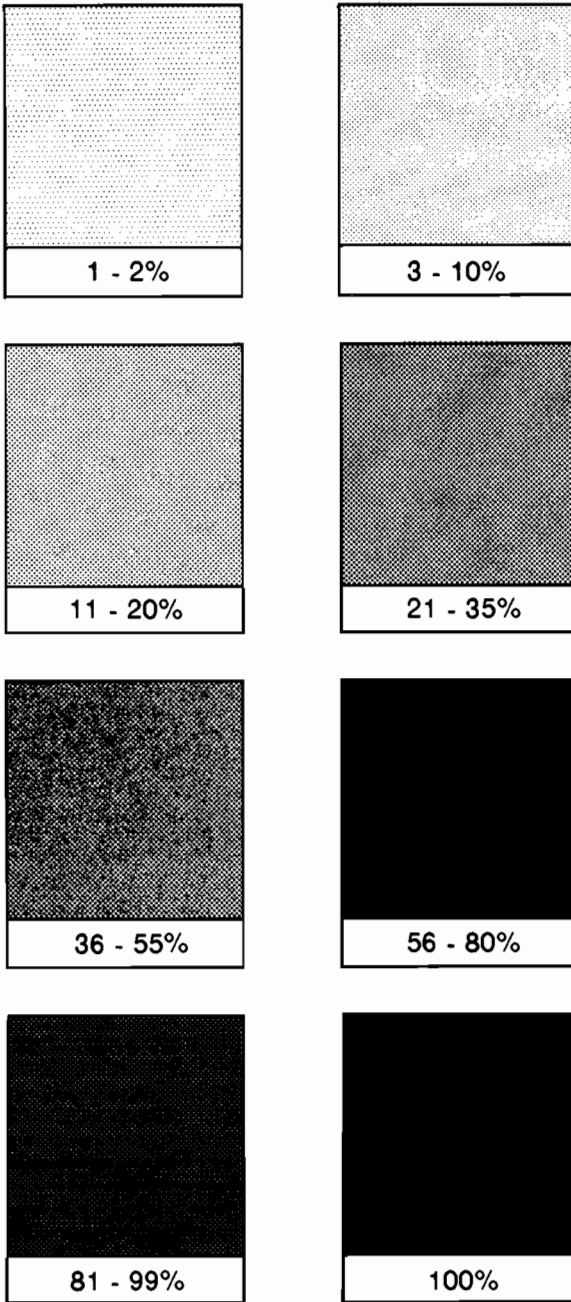

Figure 3-6. Gray Scale Patterns

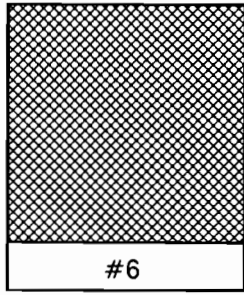
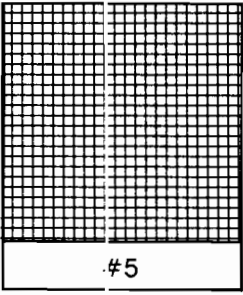
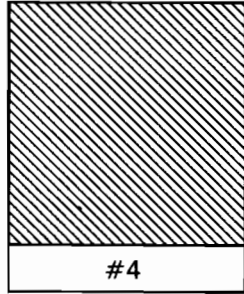
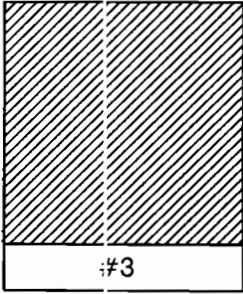
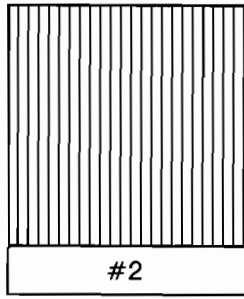
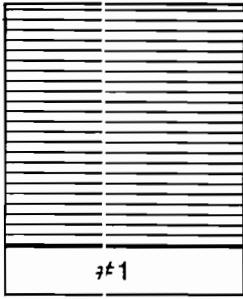

Figure 3-7. HP-Defined Patterns

## PRINT RULE/PATTERN – $\text{E}_c^*c\#P$

This escape sequence specifies whether a rule, gray scale pattern, or HP-defined pattern is to be printed, and commands the printer to print the specified rule or pattern. When a print rule/pattern command is received, the rectangle defined by the last rule/pattern size escape sequences is filled with the specified pattern. If a gray scale or HP-defined pattern is specified, the printer will print the pattern associated with the last specified pattern ID. The following value field (#) numbers specify whether a rule, gray scale pattern, or HP-defined pattern will be printed:

| # Value | Pattern Definition |
|---------|--------------------|
| 0       | Black Rule         |
| 2       | Gray Scale Pattern |
| 3       | HP-Defined Pattern |

The reference point of a rule/pattern is the upper left corner of the image and is relative to the page orientation. Printing a rule/pattern does not change the current active cursor position value. (In other words, following the printing of a rule/pattern, the cursor returns to the position it was in before the print rule/pattern escape sequence was sent.) Rules and patterns are not affected by margins, perforation skip mode, or end-of-line wrap. A rule/pattern may extend beyond the margins, but will be truncated at the maximum printable limits of the printer.

### RULE EXAMPLE

This example creates a solid black rectangle (rule) 1/10-inch high by 3 inches wide beginning 1 inch from the left and 2 inches down from the top left corner of the page:

$\text{E}_c\&a720h1440V$  – Moves cursor to starting position (1 inch to the right and 2 inches down).

$\text{E}_c^*c2160h72V$  – Sets the horizontal and vertical rule size in decipoints.

$\text{E}_c^*c0P$  – Prints the rule.

## GRAY SCALE EXAMPLE

This example fills an 8-inch high by 10-inch wide area with a 25 percent gray scale pattern:

`E_c*c5760h7200V` -- Sets the horizontal and vertical pattern size (in decipoints).

`E_c*c25G` -- Sets the pattern ID for 25% gray scale pattern.

`E_c*c2P` -- Prints the gray scale pattern.

## PATTERN EXAMPLE

This example fills an 8-inch high by 10-inch wide area with an HP-defined pattern (in this case, a horizontal bar):

`E_c*c5760h7200V` -- Sets the horizontal and vertical pattern size (in decipoints).

`E_c*c1G` -- Sets the pattern ID to the horizontal bar.

`E_c*c3P` -- Prints the HP-defined pattern.





---

# Chapter IV

---

---

## LASERJET 500+

---

### ADDITIONAL

---

### PRINTER FEATURES

---

## Introduction

This chapter describes the features which are specific to the LaserJet 500+ printer. The features of the LaserJet 500+ printer are the same as the LaserJet+ except for the paper feed features.

This chapter contains the following information:

|   |      |
|---|------|
| Sheet Feeder Control . . . . .                            | 4-2  |
| Job Offset Control . . . . .                              | 4-4  |
| Job Offset Example . . . . .                              | 4-6  |
| Paper Input Control . . . . .                             | 4-7  |
| Selecting Page Length . . . . .                           | 4-8  |
| Sheet Feeder Control Example #1 . . . . .                 | 4-9  |
| Sheet Feeder Control Example #2 . . . . .                 | 4-9  |
| Sheet Feeder Control Example #3 . . . . .                 | 4-10 |
| Paper Input Control/Job Offset Control Example . . . . .  | 4-10 |
| Configuring the Auto-Select Mode Power-On State . . . . . | 4-11 |

# Sheet Feeder Control

The LaserJet 500+ printer has job offset control and dual paper cassettes which allow greater input capacity and programmable cassette selection. In addition, the printer allows you to choose face-up stacking or face-down (correct-order) stacking by switching the paper stacking lever position. (The correct-order/reverse-order stacking feature is not programmatically controlled.)

As discussed in the LaserJet 500+ Printer Operator's Manual, the printer has an auto cassette sequencing feature (auto-select mode). This feature allows the printer to automatically select paper from the alternate cassette if a paper-out condition occurs (the paper in both cassettes must be the same size). In auto-select mode, if a page size change is requested and the current cassette doesn't have the appropriate paper size, the alternate cassette will be selected if it contains the requested size paper. *Hewlett-Packard recommends using the auto-select mode when the paper in both cassettes is equal (both same size and type) and recommends NOT using auto-select mode when different paper is loaded in each cassette.*

Auto-select mode is enabled from the Operator Control Panel and is not programmatically selectable. Normally, when the printer powers-up, the auto-select mode is off. However, a switch on the printer allows you to power-up the printer with the auto-select mode on (see "Configuring the Auto-Select Mode Power-on State" in this chapter).

Resetting the printer does not affect whether the auto-select mode is on or off, but it returns the cassette selection to the upper cassette (the upper cassette is the default for both normal and auto-select modes). Power-off resets the printer to the auto-select mode default. In auto-select mode, if the printer receives a reset (E<sub>c</sub>E), Operator Control Panel reset, or power-off/on occurs while the upper cassette is missing from the printer, the page length will be defaulted to letter-size. HP recommends that, when the upper cassette has anything other than letter-size paper loaded, the printer should be placed off-line before removing either cassette to add paper.

The use or selection of the auto-select mode, upper cassette, lower cassette, and the manual paper feed feature is indicated by lights

(LEDs) on the Operator Control Panel. For more information on the auto-select mode, see the LaserJet 500+ Printer Operator's Manual (part no. 02686-90911).

Three escape sequences are used to control the LaserJet 500+ printer paper feed features:

- Job Offset Control ( $\text{E}_c\&\#T$ )
- Paper Input Control ( $\text{E}_c\&\#H$ )
- Select Page Length ( $\text{E}_c\&\#P$ )

The **job offset control** escape sequence is used for job separation. The **paper input control** escape sequence and/or the **select page length** escape sequence are used to specify the input paper source. The **paper input control** escape sequence specifies whether you want to feed paper from the upper cassette (default), lower cassette, manual feed, or envelope feed. **NOTE: In auto-select mode, you may not select the upper or lower cassette using the paper input control escape sequence ( $\text{E}_c\&\#11H$  and  $\text{E}_c\&\#14H$  are not functional in the auto-select mode).** The **select page length** escape sequence is useful when the printer is in the auto-select mode and two different sizes of paper are loaded. Which escape sequence you use (**paper input control** or **select page length**) depends on the specific application. Since the LaserJet 500+ printer has two paper input cassettes and allows several different paper sizes, there are many variations of how jobs may be implemented. Table 4-1 illustrates some recommended paper cassette configurations and the recommended escape sequence used for selecting cassettes in these configurations.

TABLE 4-1. RECOMMENDED PAPER TRAY CONFIGURATION

| Upper Tray | Lower Tray | Auto-Select Mode | Recommended Escape Sequence |
|------------|------------|------------------|-----------------------------|
| Letter     | Letter     | ON               | None Required               |
| Letter     | Letterhead | OFF              | $\text{E}_c\&\#H$           |
| Letter     | Legal      | OFF              | $\text{E}_c\&\#h\#P$        |

When different sizes of paper are loaded in the upper and lower cassettes, we recommend that both the **paper input control** and **select page length** escape sequences (in the order shown here— $\text{E}_c\&\#h\#P$ ) be sent to the printer when selecting a cassette.

If both escape sequences are sent, the correct cassette will be selected in both the normal and auto-select modes.

The **job offset control**, **paper input control**, and **select page length** escape sequences are explained in more detail in the following paragraphs.

## JOB OFFSET CONTROL

Job offset control allows you to shift the output stacking position between jobs to allow for easy separation of print jobs.

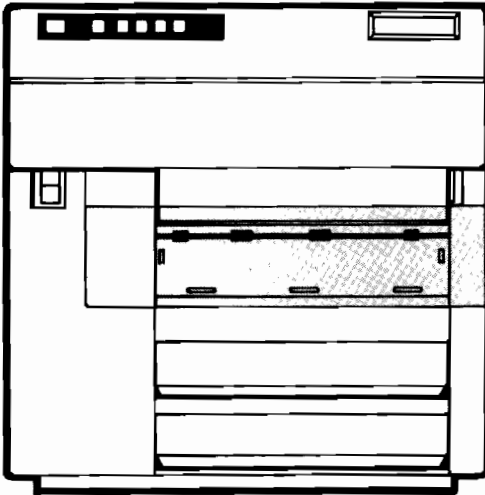

Front View of Printer

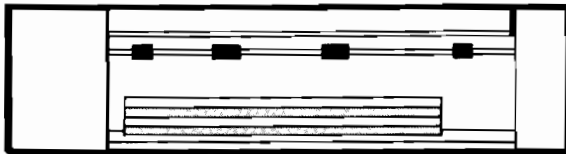

Normal Stacking

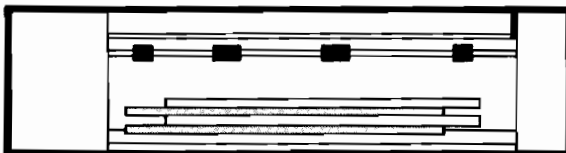

Offset Stacking

---

|             |
|-------------|
| <b>NOTE</b> |
|-------------|

Reset does not affect the job offset position; power-down defaults the stacking position.

Job offset can only be performed when face-down printing (correct-order stacking) is selected by the operator.

---

The following escape sequence controls job offset:

`Esc&10T` -- Sets the stacking position to the default position

`Esc&11T` -- Toggles the stacking position

The `Esc&10T` escape sequence is used to set the stacker to a known position (the default position) and the `Esc&11T` sequence sets the stacker to the position opposite that of the previous stacking position. (The default stacking position is the left position when facing the front of the printer.) When the `Esc&11T` escape sequence is sent, the stacking position does not toggle until the current page is closed and sent for printing. Once the stacking position is changed the printed output will continue to stack in that position until the position is programmatically changed (`Esc&11T`) or the printer is powered-off.

The stacking position does not change automatically between jobs; job offset must be explicitly commanded using the `Esc&1#T` escape sequence.

## JOB OFFSET EXAMPLE

This example demonstrates the simplicity of job offset control. At the beginning of the job, we recommend that an  $\text{E}$  be sent to reset parameters and an  $\text{c\&11T}$  be sent to toggle the stacking position as follows:

### Job Number 1

$\text{E}$ —Resets the printer

$\text{c\&11T}$ —Toggles the stacking position

Text for job number 1

### Job Number 2

$\text{E}$ —Resets the printer

$\text{c\&11T}$ —Toggles the stacking position

Text for job number 2

### Job Number 3

$\text{E}$ —Resets the printer

$\text{c\&11T}$ —Toggles the stacking position

Text for job number 3

The  $\text{c\&10T}$  escape sequence is sent following the reset in cases that require the stacking position be set to a known state. If this escape sequence is sent, however, the possibility exists that two consecutive jobs will not be offset since the job prior to the escape sequence ( $\text{c\&10T}$ ) may have already been stacking in the default position.

## PAPER INPUT CONTROL

The paper input control escape sequence allows you to take advantage of the printer's dual paper input cassette feature. Using this escape sequence, you may specify which cassette you wish to print from (when NOT in auto-select mode) or you may select the manual feed or envelope feed modes. For example, you can put letterhead in the lower cassette and regular letter-size paper in the top cassette and then you may programmatically select the correct paper for your job.

The following escape sequence allows you to control the method of paper input:

$E_c\&l\#H$

The value field (#) specifies the paper input method as shown in the following table:

TABLE 4-2. PAPER INPUT CONTROL VALUES

| #   | Printer Action  |
|-----|---|
| 0   | Eject the current page                                      |
| * 1 | Feed paper from <i>upper</i> paper input cassette (default) |
| 2   | Feed from manual feed slot                                  |
| 3   | Feed envelope in manual feed slot                           |
| * 4 | Feed paper from <i>lower</i> paper input cassette           |



\* The printer does not respond to  $E_c\&l1H$  and  $E_c\&l4H$  when in auto-select mode.

The printer default is to feed paper from the upper cassette; this also occurs if an illegal value (#) is specified in the  $E_c\&l\#H$  escape sequence. When this escape sequence is received during the formatting of a page, the current page formatting is immediately halted and a Carriage Return and Form Feed is executed. The next page is then fed as specified by the  $E_c\&l\#H$  escape sequence (when auto-select mode is off). This command remains effective until another cassette is selected or a reset is received. This escape sequence also causes the appropriate Operator Control Panel

indicator (U. CASSETTE, L. CASSETTE, or MANUAL) to illuminate.

When feeding paper from the manual feed slot, the manual feed indicator on the Operator Control Panel illuminates and the appropriate paper size alternately flashes on the **status display** (L = letter, LL = legal, A4 = A4, and b5 = B5) with the **PF** (Paper Feed) request. Note, however, that the **PF** request does not show up on the display until the page is ready to be printed (when the page is full or a Form Feed is sent).

To return from the manual feed mode to the auto-select mode, the paper input control escape sequence ( $\text{E}_c\&\#H$ ) may be used to select the desired input cassette to resume printing. A programmable reset ( $\text{E}_cE$ ) may also be used to return to auto-select mode, in which case the upper cassette is selected and the page length setting defaults to the upper cassette paper size.

When an envelope feed is requested ( $\text{E}_c\&\#13H$ ), **PE** flashes on the display indicating that an envelope should be fed into the printer.

## SELECTING PAGE LENGTH

The page length escape sequence,  $\text{E}_c\&\#P$ , controls the **LaserJet 500+** printer the same as the **LaserJet/LaserJet+** printers, but the addition of the dual paper feed feature requires some additional explanation.

If different sizes of paper are loaded in the two paper cassettes, we recommend that the printer be in normal mode (NOT auto-select mode) and that the desired cassette be selected using the  $\text{E}_c\&\#h\#P$  escape sequence. However, if auto-select mode is on and the paper input cassettes have different sizes of paper loaded, paper feed from the desired cassette can be accomplished by specifying only the desired page size ( $\text{E}_c\&\#P$ ). (Note that sending the page length escape sequence also defaults the top margin, text length, and left/right margins.)

When the page length is defaulted (by sending the  $\text{E}_c\&\#10P$  escape sequence), the page size defaults to that of the *selected* cassette. It should be noted that defaulting the page length this way may slow down the print job.



Selecting page length when in manual feed mode causes the current page to be ejected and the appropriate page size requested by alternately flashing PF (or PE) and the paper size.

If a page size request is different than the current page size, then UC, LC, or PF (for Upper Cassette, Lower Cassette and Paper Feed) is alternately displayed with the new page size (L = Letter, LL = Legal, A4 = A4, B5 = B5). For example, if the upper cassette is selected and a page size of 84 lines (14 inches at 6 lines/inch) is specified, the display will alternately flash UC and LL. Likewise, if the printer is in manual feed mode and a 66 line page (11 inches at 6 lines/inch) is specified, the display will alternately flash PF and L. **NOTE: This paper request will only occur when the printer cannot find the correct size paper in the paper cassettes available for selection (the available cassettes are the currently selected cassette [with auto-select OFF] or the upper or lower cassette [with auto-select ON]).**

#### **SHEET FEEDER CONTROL EXAMPLE #1**

If you have the same paper in both cassettes (for example, plain letter-size paper), we recommend that the printer be placed in auto-select mode. This allows the alternate cassette to be selected when the current cassette runs out of paper. When the printer is printing from the alternate cassette, the operator may remove the empty cassette and fill it with paper without interrupting the current job. In this example, since both cassettes contain the same kind of paper and the printer is in auto-select mode, you would not need escape sequences to alternate paper input cassettes. (If paper other than letter-size paper is used in this example, we suggest that the printer be taken off-line before loading paper. This avoids the possibility of defaulting to letter-size paper if a reset is sent to the printer while the upper cassette is removed.)

#### **SHEET FEEDER CONTROL EXAMPLE #2**

In this example, plain letter-size paper is in the upper cassette and letter-size paper with a company logo (letterhead) is in the lower cassette. In this situation, we recommend that the printer *not* be in the auto-select mode to avoid unintentional printing on the letterhead if the upper cassette has a paper-out condition. In this example, the printer would use the plain letter-size paper from the upper cassette until the **Fc&14H** escape sequence selected the

letterhead in the lower cassette. Once the page of letterhead is printed, the `^c&11H` escape sequence would be sent to resume printing from the upper cassette. A typical example might run as follows:

`^cE`–Reset printer (defaults to upper cassette)

`^c&14H`–Feed letterhead from lower cassette

Text for letterhead page

`^c&11H`–Feed regular paper from upper cassette

Text for page 2

Text for page 3

Text for page 4

End of job

`^cE`–Reset printer

`^c&14H`–Feed letterhead paper for first page of second job

Text for letterhead page

`^c&11H`–Feed regular paper from upper cassette

### **SHEET FEEDER CONTROL EXAMPLE #3**

In this example, the upper cassette has plain letter-size paper and the lower cassette has plain legal-size paper. We recommend that the printer be in normal mode (NOT auto-select) with the most commonly used paper size loaded in the upper cassette. The escape sequences in this example first select the desired cassette using the paper input control escape sequence (`^c&l#H`) and then select the correct page length (`^c&l#P`). Using both escape sequences allows the printer to select and print from the proper cassette in both the normal and auto-select modes.

`^cE`–Reset printer (defaults to upper cassette)

`^c&11h66P`–Selects cassette with letter-size paper (66 lines/page)

Text for letter-size page

`^c&14h84P`–Selects cassette with legal-size paper (84 lines/page)

Text for legal-size page

`^c&11h66P`–Selects cassette with letter-size paper (66 lines/page)

### **PAPER INPUT CONTROL/JOB OFFSET CONTROL EXAMPLE**

This example combines job offset with paper input control. In this case, the lower cassette contains letterhead and the upper cassette contains regular letter-size paper (auto-select mode off).

⌘E—Reset the printer

⌘11T—Shift output stack to separate job from previous job

⌘14H—Feeds from the lower cassette (letterhead)

Text for first page of letter

⌘11H—Feeds from upper cassette (blank paper)

Text for remaining pages of letter

## Configuring the Auto-Select Mode Power-On State

The auto-select cassette sequencing feature is configured at the factory to power-up in the off state. By changing a switch, the power-up state may be changed so that the printer automatically enters the auto-select mode. Follow the instructions below to set the printer so that auto-select mode is automatically enabled when powered-up:

- a. Switch the printer power to the OFF (0) position and unplug the AC power cord from the AC outlet.
- b. Remove the rear panel of the printer by removing the four screws as shown below.

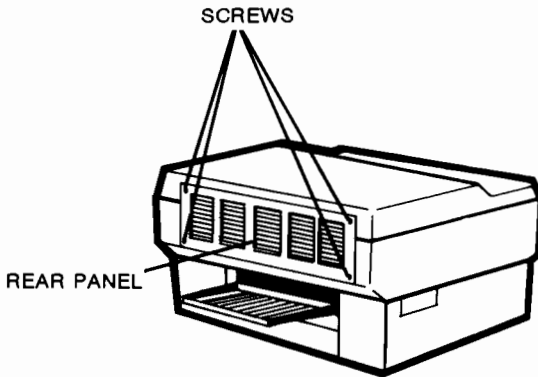

- c. Remove the vertical support bracket (1 screw) at the center of the cabinet as shown on the next page.

REAR VIEW OF PRINTER

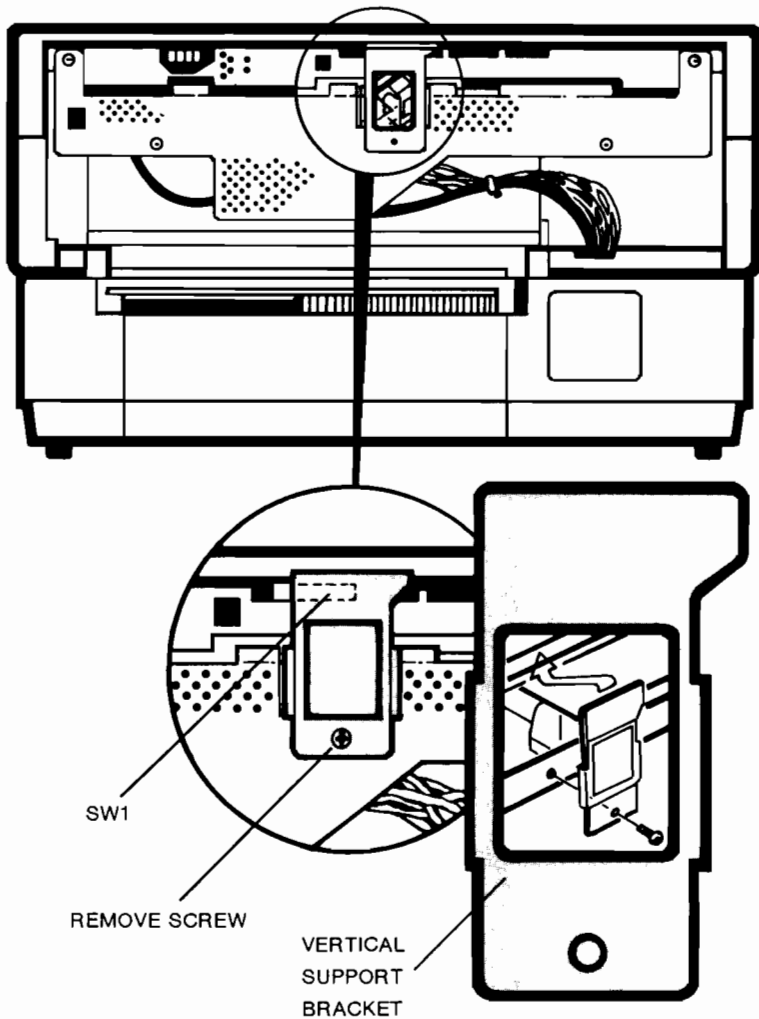

- d. Set switch number 7 of SW1 to the ON position to enable power-up with the auto-select mode ON. (The factory setting of this switch is the OFF position; in this position, the printer powers-up with the auto-select mode OFF.)

- e. Replace the vertical support bracket removed in step c.
- f. Replace the rear panel with the four screws removed in step b.
- g. Plug in the AC power cord, switch the printer's power ON (1), and resume operation.



---

# Chapter V

---

---

## PROGRAMMING HINTS

---

---

---

### Introduction

This chapter is designed to increase your understanding of some of the issues involved when programmatically controlling the LaserJet printer family. This understanding will increase your efficiency in developing or using software with the LaserJet printer family, thus enhancing productivity.

Considerations in the areas of page printing, page formatting, raster data transfer, and font selection are discussed. These areas are followed by a discussion of raster graphics issues and miscellaneous printer features such as automatic underlining and printing multiple copies. Printer issues specific to the LaserJet<sup>+</sup> and LaserJet 500<sup>+</sup>, such as throughput and managing and selecting downloaded fonts, are also discussed.

This chapter contains the following information:

|                            |      |
|----------------------------|------|
| Page Printing . . . . .    | 5-2  |
| Page Formatting . . . . .  | 5-3  |
| Font Selection . . . . .   | 5-7  |
| Raster Graphics . . . . .  | 5-8  |
| Auto-Underlining . . . . . | 5-9  |
| Multiple Copies . . . . .  | 5-12 |

|   |      |
|---|------|
| LaserJet+/LaserJet 500+ Throughput . . . . .      | 5-12 |
| LaserJet+/LaserJet 500+ Font Management . . . . . | 5-13 |
| Selecting Downloaded Fonts. . . . .               | 5-14 |
| Sending Binary Data. . . . .                      | 5-15 |

## Page Printing

The **LaserJet** family printers are page printers. This means the printer buffers a full page of data before the actual process of printing on paper begins. Therefore, page ejection and the order in which device control sequences are sent are major issues to consider.

Since the printer uses the page printing process, a page is only ejected for printing when one of the following occurs:

- the printer receives a form feed ( $F_F$ ) character
- the cursor has passed the end of the page
- the printer receives a reset command ( $E_cE$ )—HP recommends using  $E_cE$  as a job separator at the beginning and end of a job
- the printer receives a command to change the current page orientation or page length
- the printer is manually instructed to eject a page (when there is printable data in the buffer) by an operator using the FORM FEED key

If none of the above occurs, data remaining in the buffer is not ejected and data received afterward is added to the page currently in the buffer. (NOTE: the FORM FEED indicator on the display illuminates when there is data in the buffer.)

The page printing process affects the sequence in which device control characters should be sent to the printer. The preferred method of ejecting a page is CR-FF, not FF-CR.

The order in which escape sequences are sent to the printer must also be considered. For example, a change in page orientation should be specified prior to a text length command, since the page orientation change causes the text length to be set to the default value. Other considerations in the ordering of escape sequences are discussed later in this chapter.



# Page Formatting

Before a page can be formatted, consideration of the addressable and printable areas is necessary. Addressable areas are the lines and columns to which the current active cursor position (left edge of the baseline of the character) may be moved or positioned, while printable areas are the lines and columns to which characters may be printed. (Note that position 0,0 is the left-most print position at the top margin. The starting baseline position is 72% of one line from the top margin at the current vertical line spacing.) Tables 4-1 and 4-2 list the addressable and printable areas for the four paper sizes supported for LaserJet family printers. Table 4-3 lists the printer's default margins.

TABLE 5-1. ADDRESSABLE AREAS

| Paper Size<br>Size | Orient. | ADDRESSABLE AREAS |      |         |        |           |  |
|--------------------|---------|-------------------|------|---------|--------|-----------|--|
|                    |         | LINES             |      | COLUMNS |        |           |  |
|                    |         | 6LPI              | 8LPI | 10 CPI  | 12 CPI | 16.66 CPI |  |
| Letter             | Port.   | 66                | 88   | 80      | 96     | 132       |  |
|                    | Land.   | 51                | 68   | 106     | 127    | 176       |  |
| Legal              | Port.   | 84                | 112  | 80      | 96     | 132       |  |
|                    | Land.   | 51                | 68   | 136     | 163    | 226       |  |
| A4                 | Port.   | 70                | 93   | 77      | 93     | 129       |  |
|                    | Land.   | 49                | 66   | 112     | 135    | 188       |  |
| B5                 | Port.   | 60                | 80   | 66      | 80     | 111       |  |
|                    | Land.   | 42                | 57   | 97      | 116    | 162       |  |

TABLE 5-2. PRINTABLE AREAS

| Paper Size | Orient. | PRINTABLE AREAS |      |         |        |           |
|------------|---------|-----------------|------|---------|--------|-----------|
|            |         | LINES           |      | COLUMNS |        |           |
|            |         | 6LPI            | 8LPI | 10 CPI  | 12 CPI | 16.66 CPI |
| Letter     | Port.   | 62              | 84   | 80      | 96     | 132       |
|            | Land.   | 48              | 63   | 106     | 127    | 176       |
| Legal      | Port.   | 80              | 108  | 80      | 96     | 132       |
|            | Land.   | 48              | 63   | 136     | 163    | 226       |
| A4         | Port.   | 66              | 89   | 77      | 93     | 129       |
|            | Land.   | 46              | 61   | 112     | 135    | 188       |
| B5         | Port.   | 56              | 76   | 66      | 80     | 111       |
|            | Land.   | 39              | 52   | 97      | 116    | 162       |

TABLE 5-3. DEFAULT MARGINS

| Paper Size<br>Size | Orient. | DEFAULT MARGINS (INCHES) |       |      |        |
|--------------------|---------|--------------------------|-------|------|--------|
|                    |         | LEFT                     | RIGHT | TOP  | BOTTOM |
| Letter             | Port.   | .157                     | .315  | .500 | .500   |
|                    | Land.   | .200                     | .200  | .500 | .500   |
| Legal              | Port.   | .157                     | .315  | .500 | .500   |
|                    | Land.   | .200                     | .200  | .500 | .500   |
| A4                 | Port.   | .157                     | .315  | .500 | .500   |
|                    | Land.   | .200                     | .200  | .500 | .500   |
| B5                 | Port.   | .157                     | .315  | .500 | .500   |
|                    | Land.   | .200                     | .200  | .500 | .500   |

Due to physical restrictions, the first two lines and last two lines in the portrait orientation are unprintable areas. Also, the first two lines and the last two lines are unprintable areas in the landscape orientation (at 6 lines per inch vertical line spacing). In addition, at 8 lines per inch vertical line spacing, the first three lines and the last two lines are unprintable areas in the landscape orientation. *If any part of a character cell is positioned in the unprintable area, that character will not be printed.*

With an understanding of addressable and printable areas, the issue of setting margins may be discussed. The top margin is set using the `ESC#E` escape sequence explained in Chapter 2 of this manual. The bottom margin has no explicit escape sequence. The bottom margin is set implicitly via the page length, top margin and text length commands. To illustrate, assume an 8.5" x 11" page with a top margin of 2 lines (VMI set to 8/48") and a text length of 62 (VMI remaining at 8/48"). The bottom margin would be calculated as follows:

$$\begin{aligned} \text{bottom margin} &= \text{page length} - (\text{top margin} + \text{text length}) \\ &= 528/48" - (16/48" + 496/48") \\ &= 16/48" \\ &= 2 \text{ lines (using a VMI of } 8/48\text{")} \end{aligned}$$

The left and right margin escape sequences set the side margins to an absolute position calculated by the current print pitch or HMI setting and the specified column setting. A left margin setting uses the left edge of the specified column, while a right margin setting uses the right edge. Since both side margin commands are dependent on the current print pitch or HMI setting, it is recommended that when used, the desired HMI setting is sent prior to the left or right margins. The following BASIC examples illustrate this point. In the program on the left, the left margin is set only once and is set before any font changes (which affect print pitch and HMI). In the program on the right, the left margin is set to the same column position after each font change. Notice how the left margin position changes since the "set left margin" command uses the current HMI/print pitch.

10 LPRINT CHR\$(27);"E"  
20 LPRINT CHR\$(27);"&a10L";  
30 LPRINT "This is Courier"  
40 LPRINT CHR\$(13);CHR\$(10);  
50 LPRINT CHR\$(27);"OU";  
60 LPRINT CHR\$(27);"(s1p14.4v3B";  
70 LPRINT "This is Helv"  
80 LPRINT CHR\$(13);CHR\$(10);  
90 LPRINT CHR\$(27);"(s1p10v3B";  
100 LPRINT "This is Tms Rmn Bold"  
110 LPRINT CHR\$(13);CHR\$(10);  
120 LPRINT CHR\$(27);"(s1p10v0B";  
130 LPRINT "This is Tms Rmn"  
140 LPRINT CHR\$(13);CHR\$(10);  
150 LPRINT CHR\$(27);"(s1p10v1S";  
160 LPRINT "This is Tms Rmn Italic"  
170 LPRINT CHR\$(13);CHR\$(10);  
180 LPRINT CHR\$(27);"(s1p8v0S";  
190 LPRINT "This is Tms Rmn Light"  
200 LPRINT CHR\$(13);CHR\$(12);

This is Courier

**This is Helv**

**This is Tms Rmn Bold**

This is Tms Rmn

*This is Tms Rmn Italic*

This is Tms Rmn Light

10 LPRINT CHR\$(27);"E"  
15 LPRINT CHR\$(27);"OU";  
20 LPRINT CHR\$(27);"(s1p14.4v3B";  
30 LPRINT CHR\$(27);"&a10L";  
40 LPRINT "This is Helv"  
50 LPRINT CHR\$(13);CHR\$(10);  
60 LPRINT CHR\$(27);"(s1p10v3B";  
70 LPRINT CHR\$(27);"&a10L";  
80 LPRINT "This is Tms Rmn Bold"  
90 LPRINT CHR\$(13);CHR\$(10);  
100 LPRINT CHR\$(27);"(s1p10v0B";  
110 LPRINT CHR\$(27);"&a10L";  
120 LPRINT "This is Tms Rmn"  
130 LPRINT CHR\$(13);CHR\$(10);  
140 LPRINT CHR\$(27);"(s1p10v1S";  
150 LPRINT CHR\$(27);"&a10L";  
160 LPRINT "This is Tms Rmn Italic"  
170 LPRINT CHR\$(13);CHR\$(10);  
180 LPRINT CHR\$(27);"(s1p8v0S";  
190 LPRINT CHR\$(27);"&a10L";  
200 LPRINT "This is Tms Rmn Light"  
210 LPRINT CHR\$(13);CHR\$(12);

**This is Helv**

**This is Tms Rmn Bold**

This is Tms Rmn

*This is Tms Rmn Italic*

This is Tms Rmn Light

# Font Selection

Font selection, as explained in Chapter 2 of this manual, uses a procedure based on a prioritization of font characteristics. Therefore, to ensure the desired font is selected, it is recommended that each of the attributes for the desired font be sent to the printer. For example, to select the internal landscape Courier font, send the following:

```
E_c&110E_c(8UE_c(s0PE_c(s10HE_c(s12VE_c(s0SE_c(s0BE_c(s3T
```

or by combining escape sequences:

```
E_c&110E_c(8UE_c(s0p10h12v0s0b3T
```

Selection of a secondary font is executed in a similar manner. The only difference is: the "(" character in the escape sequence. For example, to select the landscape Courier as a secondary font send the following:

```
E_c&110E_c)8UE_c)s0PE_c)s10HE_c)s12VE_c)s0SE_c)s0BE_c)s3T
```

or by combining escape sequences:

```
E_c&110E_c)8UE_c)s0p10h12v0s0b3T
```

Notice the parameter zed character changed from a "(" to a ")" in all but the orientati<sup>o</sup>n escape sequence. It is impossible to select a primary and secondary font in different orientations.

Shift In and Shift Out are used to access the selected primary and secondary fonts. When sending a Shift In or Shift Out, the HMI is reset to the HMI value of the newly selected font. Therefore, if the HMI is used to override the selected font pitch, you would need to resend the HMI escape sequence following a Shift In or Shift Out. (It is recommended that the desired HMI value be sent after every font change [e.g. Shift In, Shift Out,...].)

For those who desire a bold font using only the printer's internal fonts, the following BASIC program illustrates an overstriking procedure to create bold characters. It is recommended, however, that if the application requires a full page of bold printing, a designed bold font should be used.

```

10 WIDTH "LPT1:";255 (or 10 WIDTH LPRINT 255)
20 LPRINT CHR$(27);"E";
30 LPRINT "This is Courier regular."
40 LPRINT "This is Courier bold";CHR$(27);"&a-284H";"bold";
50 LPRINT CHR$(27);"&a-284H";"bold";

```

This is Courier regular.  
This is Courier **bold**

## Raster Graphics

Graphic images printed by the printer are sent in raster form. This means each bit corresponds to a dot or pixel on the page. (The representation of a dot is dependent on the resolution, i.e. one dot at a resolution of 150 dots per inch is actually 4 dots.) It helps, then, to have the capability of positioning graphics using dot moves. This is accomplished by setting the HMI and VMI values equal to a dot at the current resolution or by using the dot positioning commands (LaserJet<sup>+</sup>/LaserJet 500<sup>+</sup> only). The following example illustrates the calculation of the HMI and VMI values for a dot at 300 dots/inch resolution:

$$\begin{array}{rcl}
 & \# & 1 \\
 \text{HMI} & = & \frac{\text{---}}{120} = \frac{\text{---}}{300} \\
 & & 120 \\
 & \# & = \frac{\text{---}}{300} \\
 & \# & = .4 \\
 \\
 \text{VMI} & = & \frac{\text{---}}{48} = \frac{\text{---}}{300} \\
 & & 48 \\
 & \# & = \frac{\text{---}}{300} \\
 & \# & = .16
 \end{array}$$

After setting the HMI and VMI to the values above, positioning the cursor x number of dots horizontally or vertically is done by sending the row or column cursor positioning command.

To illustrate, the following BASIC program prints one line on the first dot row followed by a second line positioned on dot row 3, beginning in dot column 9.

```
10 WIDTH LPRINT 255
20 LPRINT CHR$(27);"E";
30 REM **SET HMI TO 1 DOT/COLUMN**
40 LPRINT CHR$(27);"&k.4H";
50 REM **SET VMI TO 1 DOT/ROW**
60 LPRINT CHR$(27);"&l.16C";
70 LPRINT CHR$(27);"t300R";
80 LPRINT CHR$(27);"r0A";
90 LPRINT CHR$(27);"b3W";CHR$(255);CHR$(255);
100 LPRINT CHR$(255);
110 LPRINT CHR$(27);"rB";
120 LPRINT CHR$(27);"&a3r9C";
130 LPRINT CHR$(27);"r1A";
140 LPRINT CHR$(27);"b3W";CHR$(255);CHR$(255);
150 LPRINT CHR$(255);
160 LPRINT CHR$(27);"rB";
170 LPRINT CHR$(13);
180 LPRINT CHR$(12);
```

## Automatic Underlining

Underlining an entire line or a portion of a line may be executed in either of two ways by the printer:

- by using the underscore character or
- by using the automatic underlining feature

Each, however, generates different results. The most obvious difference is in regards to the positioning of the underline. Using the underscore character, the underline is positioned below the bottom of a descending lowercase letter. To illustrate, send the following BASIC program to the printer:

```
10 LPRINT CHR$(27);"E";
20 LPRINT "Using underscore character";
30 LPRINT CHR$(27);"&a-9C";
40 LPRINT "          "
50 LPRINT CHR$(13);CHR$(12);
```

### Using underscore character

Using the automatic underlining feature of the printer, the underline is positioned closer to the baseline of the character. To illustrate, send the following BASIC program to the printer:

```
10 LPRINT CHR$(27);"E";
20 LPRINT "Using ";CHR$(27);"&dD";"auto-underlining";"&d@";
30 LPRINT CHR$(13);CHR$(12);
```

### Using auto-underlining

Another major difference in results occurs when printing with the proportional fonts. Using the automatic underlining feature of the printer, the underlining is executed correctly, taking into account the proportionality of the characters printed. However, using the underscore character to underline causes the underlining to be incorrect in length. This is due to the fact that the underscore character may not be the same width as the characters to be underscored. To illustrate, send the following BASIC program to the printer:



```

10 REM **92286B OR 92286F CARTRIDGE MUST BE
20 REM **INSTALLED TO USE THIS EXAMPLE.
30 LPRINT CHR$(27);"E";
40 LPRINT CHR$(27);"&l0O";
50 REM **LINE 60 UNNECESSARY FOR 92286F**
60 LPRINT CHR$(27);"(0U";
70 LPRINT CHR$(27);"(s1p10v0s0b5T";
80 LPRINT "Using ";CHR$(27);"&dD";"auto-underlining";
90 LPRINT CHR$(27);"&d@";
100 LPRINT CHR$(13);CHR$(10);CHR$(10);
110 LPRINT "Using underscore character";
120 LPRINT CHR$(8);CHR$(8);CHR$(8);CHR$(8);CHR$(8);
130 LPRINT CHR$(8);CHR$(8);CHR$(8);CHR$(8);
140 LPRINT "          "
150 LPRINT CHR$(13);CHR$(12);

```

Using auto-underlining

Using underscore character

Lastly, a programming tip for those who require double underlining as a feature, but for efficiency, do not want to use raster graphics. When using the fixed-space fonts, underline using the automatic underlining feature. Next, modify the VMI to 48 lines per inch, send a line feed command, and send a horizontal cursor positioning command to position the cursor back to the first character to be double underlined. Then print spaces (leaving the automatic underlining feature enabled) equivalent to the length of the string to be double-underlined. Lastly, send a negative line feed command to the printer and change the VMI back to its original value. The following example illustrates this procedure:

```

10 WIDTH LPRINT 255
20 LPRINT CHR$(27);"E";
30 LPRINT CHR$(27);"&dD";"Double underlining";
40 LPRINT CHR$(27);"&l48D";CHR$(10);CHR$(27);"&a-18C";
50 LPRINT CHR$(27);"          ";
60 LPRINT CHR$(27);"&a-1R";
70 LPRINT CHR$(27);"&l6D";CHR$(27);"&d@"
80 LPRINT "using auto-underlining."
90 LPRINT CHR$(13);CHR$(12);

```

Double underlining  
using auto-underlining.

When using proportional fonts, the positioning of the cursor becomes more difficult but the procedure is identical.

## Multiple Copies

The printer, as discussed in Chapter 2, has a command to select the number of copies. This command is recommended when the file to be printed requires a great amount of formatting. Rather than looping through the formatting process, the multiple copies command provides the output at the rate of 8 pages per minute after receiving the first copy. Note that if there are multiple pages in the file, the copies of the current page are printed before any copies of the following page.

## LaserJet+/LaserJet 500+ Throughput

The LaserJet+ and LaserJet 500+ printers can print 8 pages per minute when printing 2800-3000 characters per page of simple text. When more characters are printed or macros are executed, the speed decreases. Using other features such as rules can also slow the printer down. For example, a standard three-paragraph business letter with a macro form consisting of a medium-size logo and a page border can print as fast as 8 pages per minute with the following conditions:

- The fonts are pre-downloaded as permanent
- The forms macros are pre-downloaded as permanent
- There is no <sup>^</sup>cE between pages (just between jobs)

However, if  $\text{E}_c\text{E}$  is used between pages, and the fonts and macro forms are downloaded on each page, the throughput can drop to less than 2 pages per minute.

Communication of raster graphics to the printer can be accomplished about two to three times faster using the Centronics Parallel interface instead of the serial interface (at 19.2 Kbaud). Font downloads can be accomplished about 25% faster with the Centronics Parallel interface. (These statements assume that the host CPU can keep up with the printer's demand for data.)

If the printer receives a page to print that is too complex, it displays an error #21 and aborts the remainder of the page. This error is much more likely to occur with vertical rules than with horizontal rules because the laser beam scans horizontally across the page (in portrait orientation) and each separate image on a scan line adds overhead.

Another factor affecting printer throughput is that the printer processor must prepare all the print images for the laser in time for printing. The more separate images it must process, the closer it gets to the complexity limit. If the user receives error number 21, try to make the page less complex (for example, by avoiding too many vertical rules), or integrate the vertical rules using raster graphics (where a whole raster image simulates a series of rules). Avoid making single vertical rules with raster graphics.

## **LaserJet+/LaserJet 500+ Font Management**

In single-user environments or in multiple-user environments where the users agree on printer memory management, permanent fonts and macros are useful. The advantages of permanent fonts are higher printer throughput and simpler applications. The printer throughput is higher with permanent fonts and macros because extra downloads are avoided within the individual applications.

---

|             |
|-------------|
| <b>NOTE</b> |
|-------------|

Permanent fonts are not cleared by  $\text{E}_c\text{E}$  (reset) or by the operator pressing the RESET key. A utility program or an operating system utility such as MS-DOS COPY (with the /B option) can be used to download the fonts at the beginning of the day and assign them permanent status. See "Downloading Hewlett-Packard Fonts" in Chapter 3 for an example.

---

Applications that are designed to run in an environment where permanent fonts are loaded at the beginning of the day should avoid the escape sequence that clears all fonts ( $\text{E}_c^*\text{c}\text{ØF}$ ).

If possible, designers of applications software should avoid assigning a permanent status to fonts within application programs; applications might be more easily leveraged into multi-user environments with font management spoolers. Any fonts or macros downloaded during the execution of an application should be left temporary, so that they can be cleared with an  $\text{E}_c\text{E}$  (usually used to separate print jobs).

## Selecting Downloaded Fonts

The easiest way to select downloaded fonts (RAM fonts) is with their font ID number. Before a RAM font is downloaded, it is assigned an ID number. Subsequently, any RAM font may be activated by the escape sequence  $\text{E}_c(\#\text{X}$ , where # is the font ID number. If secondary character fonts are used, follow the  $\text{E}_c(\#\text{X}$  sequence with a Shift-In. (It is recommended that new applications not use secondary character fonts since users often need more than two fonts per page.)

RAM fonts may also be selected by their font attributes (pitch, point size, etc.) and some applications may benefit by selecting fonts this way because the font attributes are generic and printer-independent. (Other applications, however, may benefit from the simplicity of the  $\text{E}_c(\#\text{X}$  escape sequence.)

# Sending Binary Data

When sending raster graphics or downloading character fonts to the printer, binary data is transferred. One of the reasons it is called binary data is that any bit pattern may occur in the data. Some versions of BASIC programming language cause problems when transferring binary data because they interpret or translate the data. For example, if a byte of data such as a binary 9 (1001) is sent to the printer, some versions of BASIC may expand the "tab" character two spaces. Other binary data may be changed the same way, such as a carriage return being expanded to a carriage return plus a line feed. Translations such as these cause problems (such as missing areas in raster images or improperly shaped characters) when they occur. One of the reasons this manual demonstrates using the COPY utility with the /B option for downloading characters is to help avoid unwanted translations of binary data streams.

Some versions of PASCAL may translate character 26 as EOF (end of file) unless data is sent in "RAW" mode. Successful transferring of binary data has also been achieved with Lattice C using the Level 1 I/O functions: `nprn = open( "PRN:",0x8001),`  
`write ( nprn, buffer, length ),` and `close ( nprn ).`



# Appendix A

## ESCAPE SEQUENCE SUMMARY

| FUNCTION              | PARAMETER             | ESCAPE SEQUENCE  | DECIMAL VALUE                              | HEXADECIMAL VALUE                |                |
|-----------------------|-----------------------|------------------|--|----------------------------------|----------------|
| <b>ORIENTATION</b>    |                       |                  |  |                                  |                |
| ORIENTATION           | Portrait<br>Landscape | EC&100<br>EC&110 | 027 038 108 048 079<br>027 038 108 049 079 | 1B 26 6C 30 4F<br>1B 26 6C 31 4F |                |
| <b>FONT SELECTION</b> |                       |                  |  |                                  |                |
| SYMBOL SET            | Roman-8               | EC(8U)           | 027 040 056 085                            | 1B 28 38 55                      |                |
|                       | USASCII               | EC(0U)           | 027 040 048 085                            | 1B 28 30 55                      |                |
|                       | Roman Ext.            | EC(0E)           | 027 040 048 069                            | 1B 28 30 45                      |                |
|                       | Danish/<br>Norwegian  | EC(0D)           | 027 040 048 068                            | 1B 2B 30 44                      |                |
|                       | United<br>Kingdom     | EC(1E)           | 027 040 049 069                            | 1B 28 31 45                      |                |
|                       | French                | EC(0F)           | 027 040 048 070                            | 1B 28 30 46                      |                |
|                       | German                | EC(0G)           | 027 040 048 071                            | 1B 28 30 47                      |                |
|                       | Italian               | EC(0I)           | 027 040 048 073                            | 1B 28 30 49                      |                |
|                       | Swedish/<br>Finnish   | EC(0S)           | 027 040 048 083                            | 1B 28 30 53                      |                |
|                       | Spanish               | EC(1S)           | 027 040 049 083                            | 1B 28 31 53                      |                |
|                       | Legal                 | EC(1U)           | 027 040 049 085                            | 1B 28 31 55                      |                |
|                       | Linedraw              | EC(0B)           | 027 040 048 066                            | 1B 28 30 42                      |                |
|                       | Math8                 | EC(8M)           | 027 040 056 077                            | 1B 28 38 40                      |                |
|                       | Math8a                | EC(0Q)           | 027 040 048 081                            | 1B 28 30 51                      |                |
|                       | Math8b                | EC(1Q)           | 027 040 049 081                            | 1B 28 31 51                      |                |
|                       | Math7                 | EC(0A)           | 027 040 048 065                            | 1B 28 30 41                      |                |
|                       | PiFont                | EC(15U)          | 027 040 049 053 085                        | 1B 28 31 35 55                   |                |
|                       | PiFonta               | EC(2Q)           | 027 040 050 081                            | 1B 28 32 51                      |                |
|                       | SPACING               | Proportional     | EC(s1P)                                    | 027 040 115 049 080              | 1B 28 73 31 50 |
|                       |                       | Fixed            | EC(s0P)                                    | 027 040 115 048 080              | 1B 28 73 30 50 |
| PITCH                 | 10 CPI                | EC(s10H)         | 027 040 115 049 048 072                    | 1B 28 73 31 30 48                |                |
|                       | 12 CPI                | EC(s12H)         | 027 04U 115 049 050 072                    | 1B 28 73 31 32 48                |                |
|                       | 16.66 CPI             | EC(s16.6H)       | 027 040 115 049 054 046 054 072            | 1B 28 73 31 36 2F 36 48          |                |
| POINT SIZE            | 7 Pt.                 | EC(s7V)          | 027 040 115 055 086                        | 1B 28 73 37 56                   |                |
|                       | 8 Pt.                 | EC(s8V)          | 027 040 115 056 086                        | 1B 28 73 38 56                   |                |
|                       | 8.5 Pt.               | EC(s8.5V)        | 027 040 115 055 046 053 086                | 1B 28 73 38 2F 35 56             |                |
|                       | 10 Pt.                | EC(s10V)         | 027 040 115 049 048 086                    | 1B 28 73 31 30 56                |                |
|                       | 12 Pt.                | EC(s12V)         | 027 040 115 049 050 086                    | 1B 28 73 31 32 56                |                |
|                       | 14.4 Pt.              | EC(s14.4V)       | 027 040 115 049 052 046 052 086            | 1B 28 73 31 34 2F 34 56          |                |
| STYLE                 | Upright               | EC(s0S)          | 027 040 115 048 083                        | 1B 28 73 30 53                   |                |
|                       | Italic                | EC(s1S)          | 027 040 115 049 083                        | 1B 28 73 31 53                   |                |
| STROKE WEIGHT         | Light (-3)            | EC(s-3S)         | 027 040 115 045 051 066                    | 1B 28 73 2D 42                   |                |
|                       | Medium (0)            | EC(s0S)          | 027 040 115 048 066                        | 1B 28 73 30 42                   |                |
|                       | Bold (3)              | EC(s3S)          | 027 040 115 051 066                        | 1B 28 73 33 42                   |                |
| TYPEFACE              | Courier               | EC(s3T)          | 027 040 115 051 084                        | 1B 28 73 33 54                   |                |
|                       | Line Printer          | EC(s0T)          | 027 040 115 048 084                        | 1B 28 73 30 54                   |                |
|                       | Helv                  | EC(s4T)          | 027 040 115 052 084                        | 1B 28 73 34 54                   |                |
|                       | TMS RMN               | EC(s5T)          | 027 040 115 053 084                        | 1B 28 73 35 54                   |                |
|                       | Prestige Elita        | EC(s8T)          | 027 040 115 056 084                        | 1B 28 73 38 54                   |                |
|                       | Gothic                | EC(s6T)          | 027 040 115 054 084                        | 1B 28 73 36 54                   |                |

| FUNCTION   | PARAMETER  | ESCAPE SEQUENCE   | DECIMAL VALUE   | HEXADECIMAL VALUE   |
|--|--|---|---|---|
| <b>PAGE LENGTH, TOP MARGIN, AND TEXT LENGTH</b>      |  |   |   |   |
| PAGE LENGTH  | # of Lines   | EC&I#P  | 027 038 108 #... # 080  | 1B 26 6C #... # 50  |
| TOP MARGIN   | # of Lines   | EC&I#E  | 027 038 108 #... # 069  | 1B 26 6C #... # 45  |
| TEXT LENGTH  | # of Lines   | EC&I#F  | 027 038 108 #... # 070  | 1B 26 6C #... # 46  |
| <b>MARGINS</b>                                       |  |   |   |   |
| MARGINS  | Clear<br>Left (col #)<br>Right (col #)   | Ec9<br>EC&a*L<br>EC&a#M   | 027 057<br>027 038 097 #... # 076<br>027 038 097 #... # 077   | 1B 39<br>1B 26 61 #... # 4C<br>1B 26 61 #... # 4D   |
| <b>VERTICAL LINE SPACING</b>                         |  |   |   |   |
| MOTION INDEX   | # of 1/48 inch increments  | EC&I#C  | 027 038 108 #... # 067  | 1B 26 6C #... # 43  |
| LINES/INCH   | 1 line/inch<br>2 lines/inch<br>3 lines/inch<br>4 lines/inch<br>6 lines/inch<br>8 lines/inch<br>12 lines/inch<br>16 lines/inch<br>24 lines/inch | EC&I1D<br>EC&I2D<br>EC&I3D<br>EC&I4D<br>EC&I6D<br>EC&I8D<br>EC&I12D<br>EC&I16D<br>EC&I24D | 027 038 108 049 068<br>027 038 108 050 068<br>027 038 108 051 068<br>027 038 108 052 068<br>027 038 108 054 068<br>027 038 108 056 068<br>027 038 108 049 050 068<br>027 038 108 049 054 068<br>027 038 108 050 052 068 | 1B 26 6C 31 44<br>1B 26 6C 32 44<br>1B 26 6C 33 44<br>1B 26 6C 34 44<br>1B 26 6C 36 44<br>1B 26 6C 38 44<br>1B 26 6C 31 32 44<br>1B 26 6C 31 36 44<br>1B 26 6C 32 34 44 |
| <b>HALF-LINE FEED</b>                                |  |   |   |   |
| HALF-LINE FEED                                       |  | EC=   | 027 061   | 1B 3D   |
| <b>RASTER GRAPHICS</b>                               |  |   |   |   |
| RESOLUTION   | 75 Dots/inch<br>100 Dots/inch<br>150 Dots/inch<br>300 Dots/inch  | EC*t75R<br>EC*t100R<br>EC*t150R<br>EC*t300R   | 027 042 116 055 053 082<br>027 042 116 049 048 048 082<br>027 042 116 049 053 048 082<br>027 042 116 051 048 048 082  | 1B 2A 74 37 35 52<br>1B 2A 74 31 30 30 52<br>1B 2A 74 31 35 30 52<br>1B 2A 74 33 30 30 52   |
| START GRAPHICS                                       | Left-Most Pos.<br>Current Cursor   | EC*r0A<br>EC*rIA  | 027 042 114 048 065<br>027 042 114 049 065  | 1B 2A 72 30 41<br>1B 2A 72 31 41  |
| TRANSFER   | # of Rows  | EC*b#W [Data]   | 027 042 098 #... # 087  | 1B 2A 62 #... # 57  |
| END GRAPHICS   |  | EC*rB   | 027 042 114 066   | 1B 2A 72 42   |
| <b>SPECIALIZED PRINTER CONTROL</b>                   |  |   |   |   |
| RESET<br>SELF-TEST                                   |  | ECe<br>ECz  | 027 069<br>027 122  | 1B 45<br>1B 7A  |
| <b>CURSOR POSITIONING</b>                            |  |   |   |   |
| MOVE TO ROW<br>MOVE TO COL<br>HORIZONTAL<br>VERTICAL | Row #<br>Column #<br># of decipoints<br># of decipoints  | EC&a#R<br>EC&a#C<br>EC&a#H<br>EC&a#V  | 027 038 097 #... # 082<br>027 038 097 #... # 067<br>027 038 097 #... # 072<br>027 038 097 #... # 086  | 1B 26 61 #... # 52<br>1B 26 61 #... # 43<br>1B 26 61 #... # 48<br>1B 26 61 #... # 56  |



| FUNCTION  | PARAMETER  | ESCAPE SEQUENCE                      | DECIMAL VALUE  | HEXADECFMAL VALUE  |
|---|--|--------------------------------------|--|--|
| <b>UNDERLINE</b>                                    |  |                                      |  |  |
| UNDERLINE   | ON<br>OFF  | Ec&dD<br>Ec&d@                       | 027 038 100 068<br>027 038 100 064   | 1B 26 64 44<br>1B 26 64 40   |
| <b>DISPLAY FUNCTIONS AND TRANSPARENT PRINT DATA</b> |  |                                      |  |  |
| DISPLAY FUNCTIONS                                   | ON<br>OFF  | EcY<br>EcZ                           | 027 089<br>027 090   | 1B 59<br>1B 5A   |
| TRANSPARENT PRINT DATA                              | # of Bytes   | Ec&p#X [Data]                        | 027 038 112 #... # 088   | 1B 26 70 #... # 58   |
| <b>PERFORATION SKIP MODE</b>                        |  |                                      |  |  |
| PERF SKIP   | DISABLE<br>ENABLE  | Ec&10L<br>Ec&11L                     | 027 038 108 048 076<br>027 038 108 049 076   | 1B 26 6C 30 4C<br>1B 26 6C 31 4C                                     |
| <b>MISCELLANEOUS FEATURES</b>                       |  |                                      |  |  |
| HORIZONTAL MOTION INDEX                             | # of 1/120" Increments                                       | Ec&k#H                               | 027 038 107 #... # 072   | 1B 26 6B #... # 48   |
| FONT PITCH (ALTERNATE METHOD)                       | Standard Pitch   | Ec&k0S                               | 027 038 107 048 083  | 1B 26 6B 30 53   |
|   | Compressed Pitch   | Ec&k2S                               | 027 038 107 050 083  | 1B 26 6B 32 53   |
| LINE TERMINATION                                    | CR=CR LF=LF<br>FF=FF   | Ec&k0G                               | 027 038 107 048 071  | 1B 26 6B 30 47   |
|   | CR=CR+LF LF=.F<br>FF=FF                                      | Ec&k1G                               | 027 038 107 049 071  | 1B 26 6B 31 47   |
|   | CR=CR LF=CR+.F<br>FF=CR+FF                                   | Ec&k2G                               | 027 038 107 050 071  | 1B 26 6B 32 47   |
|   | CR=CR+LF<br>LF=CR+LF<br>FF=CR+FF                             | Ec&k3G                               | 027 038 107 051 071  | 1B 26 6B 33 47   |
| END OF LINE WRAP                                    | Enabled<br>Disabled  | Ec&s0C<br>Ec&s1C                     | 027 038 115 048 067<br>027 038 115 049 067   | 1B 26 73 30 43<br>1B 26 73 31 43                                     |
| SELECT NUMBER OF COPIES                             | # OF COPIES  | Ec&1#X                               | 027 038 108 #... # 088   | 1B 26 6C #... # 58   |
| PAPER INPUT CONTROL                                 | Eject Page<br>Feed From Tray<br>Manual Feed<br>Envelope Feed | Ec&10H<br>Ec&11H<br>Ec&12H<br>Ec&13H | 027 038 108 048 072<br>027 038 108 049 072<br>027 038 108 050 072<br>027 038 108 051 072 | 1B 26 6C 30 48<br>1B 26 6C 31 48<br>1B 26 6C 32 48<br>1B 26 6C 33 48 |

| FUNCTION                           | PARAMETER   | ESCAPE SEQUENCE  | DECIMAL VALUE   | HEXADECIMAL VALUE  |
|------------------------------------|---|--|---|--|
| LASERJET+/LASERJET 500+ FEATURES   |   |  |   |  |
| CURSOR POSITION                    |   |  |   |  |
| HORIZONTAL<br>VERTICAL             | # of Dots<br># of Dots  | Ec*p#X<br>Ec*p#Y   | 027 042 112 #... # 088<br>027 042 112 #... # 089  | 1B 2A 70 #... # 58<br>1B 2A 70 #... # 59   |
| FONT MANAGEMENT                    |   |  |   |  |
| FONT ID                            | Font ID #   | Ec*c#D   | 027 042 099 #... # 068  | 1B 2A 63 #... # 44   |
| CHARACTER<br>CODE                  | ASCII Code #<br>(Decimal)   | Ec*c#E   | 027 042 099 #... # 069  | 1B 2A 63 #... # 45   |
| FONT AND<br>CHARACTER<br>CONTROL   | Delete all<br>Fonts<br>Delete all<br>Temporary<br>Delete last<br>Font ID<br>Specified<br>Delete last<br>Font ID &<br>Char. Code<br>Make Temp Font<br>Make Perm. Font<br>Copy/Assign | Ec*c0F<br>Ec*c1F<br>Ec*c2F<br>Ec*c3F<br>Ec*c4F<br>Ec*c5F<br>Ec*c6F       | 027 042 099 048 070<br>027 042 099 049 070<br>027 042 099 050 070<br>027 042 099 051 070<br>027 042 099 052 070<br>027 042 099 053 070<br>027 042 099 054 070 | 1B 2A 63 30 46<br>1B 2A 63 31 46<br>1B 2A 63 32 46<br>1B 2A 63 33 46<br>1B 2A 63 34 46<br>1B 2A 63 35 46<br>1B 2A 63 36 46 |
| CREATE FONT<br>(FONT HEADER)       | # of Bytes  | Ec)s#W [Data]  | 027 041 115 #... # 087  | 1B 29 73 #... # 57   |
| DOWNLOAD<br>CHARACTER              | # of Bytes  | Ec)s#W [Data]  | 027 040 115 #... # 087  | 1B 28 73 #... # 57   |
| DESIGNATE<br>DOWNLOAD<br>CHARACTER | Primary Font<br>ID #<br>Secondary Font<br>ID #  | Ec)#X<br>Ec)#X   | 027 040 #... # 088<br>027 041 #... # 088  | 1B 28 #... # 58<br>1B 29 #... # 58   |
| FONT DEFAULT                       | Primary Font<br>Values - 0<br>1<br>2<br>3<br><br>Secondary Font<br>Values - 0<br>1<br>2<br>3  | Ec)0e<br>Ec)1e<br>Ec)2e<br>Ec)3e<br><br>Ec)0e<br>Ec)1e<br>Ec)2e<br>Ec)3e | 027 040 048 064<br>027 040 049 064<br>027 040 050 064<br>027 040 051 064<br><br>027 041 048 064<br>027 041 049 064<br>027 041 050 064<br>027 041 051 064      | 1B 28 30 40<br>1B 28 31 40<br>1B 28 32 40<br>1B 28 33 40<br><br>1B 29 30 40<br>1B 29 31 40<br>1B 29 32 40<br>1B 29 33 40   |

| FUNCTION                     | PARAMETER        | ESCAPE SEQUENCE         | DECIMAL VALUE                              | HEXADECIMAL VALUE                |
|------------------------------|------------------|-------------------------|--|----------------------------------|
| <b>MACROS</b>                |                  |                         |  |                                  |
| MACRO ID                     | Macro ID #       | EC&F#Y                  | 027 038 102 #... # 089                     | 1B 26 66 #... # 59               |
| MACRO CONTROL                | Start Macro      | EC&FOX                  | 027 038 102 048 088                        | 1B 26 66 30 58                   |
|                              | Stop Macro       | EC&F1X                  | 027 038 102 049 088                        | 1B 26 66 31 58                   |
|                              | Execute Macro    | EC&F2X                  | 027 038 102 050 088                        | 1B 26 66 32 58                   |
|                              | Call Macro       | EC&F3X                  | 027 038 102 051 088                        | 1B 26 66 33 58                   |
|                              | Enable Overlay   | EC&F4X                  | 027 038 102 052 088                        | 1B 26 66 34 58                   |
|                              | Disable Overlay  | EC&F5X                  | 027 038 102 053 088                        | 1B 26 66 35 58                   |
|                              | Delete Macros    | EC&F6X                  | 027 038 102 054 088                        | 1B 26 66 36 58                   |
|                              | Delete All       | EC&F7X                  | 027 038 102 055 088                        | 1B 26 66 37 58                   |
|                              | Temp. Macros     |                         |  |                                  |
|                              | Delete Macro ID  | EC&F8X                  | 027 038 102 056 088                        | 1B 26 66 38 58                   |
| Make Temporary               | EC&F9X           | 027 038 102 057 088     | 1B 26 66 39 58                             |                                  |
| Make Permanent               | EC&F10X          | 027 038 102 049 048 088 | 1B 26 66 31 30 58                          |                                  |
| <b>PUSH POP POSITION</b>     |                  |                         |  |                                  |
| PUSH/POP POSITION            | Push Pop         | EC&F0S<br>EC&F1S        | 027 038 102 048 083<br>027 038 102 049 083 | 1B 26 66 30 53<br>1B 26 66 31 53 |
| <b>ADVANCED GRAPHICS</b>     |                  |                         |  |                                  |
| HORIZONTAL RULE/PATTERN SIZE | # of Dots        | EC*c#A                  | 027 042 099 #... # 065                     | 1B 2A 63 #... # 41               |
| HORIZONTAL RULE/PATTERN SIZE | # of Decipoints  | EC*c#H                  | 027 042 099 #... # 072                     | 1B 2A 63 #... # 48               |
| VERTICAL RULE/PATTERN SIZE   | # of Dots        | EC*c#B                  | 027 042 099 #... # 066                     | 1B 2A 63 #... # 42               |
| VERTICAL RULE/PATTERN SIZE   | # of Decipoints  | EC*c#V                  | 027 042 099 #... # 086                     | 1B 2A 63 #... # 56               |
| PRINT RULE/PATTERN           | Rule             | EC*cOP                  | 027 042 099 048 080                        | 1B 2A 63 30 50                   |
|                              | Gray Scale       | EC*c2P                  | 027 042 099 050 080                        | 1B 2A 63 32 50                   |
|                              | HP Pattern       | EC*c3P                  | 027 042 099 051 080                        | 1B 2A 63 33 50                   |
| GRAY SCALE PATTERN ID        | 2% Gray          | EC*c2G                  | 027 042 099 050 071                        | 1B 2A 63 32 47                   |
|                              | 10% Gray         | EC*c10G                 | 027 042 099 049 048 071                    | 1B 2A 63 31 30 47                |
|                              | 15% Gray         | EC*c15G                 | 027 042 099 049 053 071                    | 1B 2A 63 31 35 47                |
|                              | 30% Gray         | EC*c30G                 | 027 042 099 051 048 071                    | 1B 2A 63 33 30 47                |
|                              | 45% Gray         | EC*c45G                 | 027 042 099 052 053 071                    | 1B 2A 63 34 35 47                |
|                              | 70% Gray         | EC*c70G                 | 027 042 099 055 048 071                    | 1B 2A 63 37 30 47                |
|                              | 90% Gray         | EC*c90G                 | 027 042 099 057 048 071                    | 1B 2A 63 39 30 47                |
|                              | 100% Gray        | EC*c100G                | 027 042 099 049 048 048 071                | 1B 2A 63 31 30 30 47             |
| HP PATTERN ID                | 1 Vert. Lines    | EC*c1G                  | 027 042 099 049 071                        | 1B 2A 63 31 47                   |
|                              | 2 Horiz. Lines   | EC*c2G                  | 027 042 099 050 071                        | 1B 2A 63 32 47                   |
|                              | 3 Diagonal Line: | EC*c3G                  | 027 042 099 051 071                        | 1B 2A 63 33 47                   |
|                              | 4 Diagonal Line: | EC*c4G                  | 027 042 099 052 071                        | 1B 2A 63 34 47                   |
|                              | 5 Grid           | EC*c5G                  | 027 042 099 053 071                        | 1B 2A 63 35 47                   |
|                              | 6 Diagonal Grid  | EC*c6G                  | 027 042 099 054 071                        | 1B 2A 63 36 47                   |

| FUNCTION               | PARAMETER  | ESCAPE SEQUENCE | DECIMAL VALUE       | HEXADECFINAL VALUE |
|------------------------|--|-----------------|---------------------|--------------------|
| LASERJET 500+ FEATURES |  |                 |                     |                    |
| JOB OFFSET CONTROL     | Default Stacking Position<br>Toggles Stacking Position | Ec&10T          | 027 038 108 048 084 | 1B 26 6C 30 54     |
|                        |  | Ec&11T          | 027 038 108 049 084 | 1B 26 6C 31 54     |
| PAPER INPUT CONTROL    | Eject Page Feed From Upper Cassette                    | Ec&10H          | 027 038 108 048 072 | 1B 26 6C 30 48     |
|                        |  | Ec&11H          | 027 038 108 049 072 | 1B 26 6C 31 48     |
|                        | Manual Feed  | Ec&12H          | 027 038 108 050 072 | 1B 26 6C 32 48     |
|                        | Envelope Feed  | Ec&13H          | 027 038 108 051 072 | 1B 26 6C 33 48     |
|                        | Feed From Lower Cassette                               | Ec&14H          | 027 038 108 052 072 | 1B 26 6C 34 48     |

# Appendix B

## ASCII TABLES

### ROMAN8 CHARACTER SET (USASCII PLUS ROMAN EXTENSION)

|                |                |                |                | b <sub>2</sub> | 0   | 0   | 0  | 0 | 0 | 0 | 0 | 1   | 1 | 1 | 1  | 1  | 1  | 1  | 1  |    |
|----------------|----------------|----------------|----------------|----------------|-----|-----|----|---|---|---|---|-----|---|---|----|----|----|----|----|----|
|                |                |                |                | b <sub>1</sub> | 0   | 0   | 0  | 1 | 1 | 1 | 1 | 0   | 0 | 0 | 0  | 1  | 1  | 1  | 1  |    |
|                |                |                |                | b <sub>0</sub> | 0   | 0   | 1  | 0 | 0 | 1 | 1 | 0   | 0 | 1 | 1  | 0  | 0  | 1  | 1  |    |
|                |                |                |                | b <sub>3</sub> | 0   | 1   | 0  | 1 | 0 | 1 | 0 | 1   | 0 | 1 | 0  | 1  | 0  | 1  | 0  |    |
|                |                |                |                |                | 0   | 1   | 2  | 3 | 4 | 5 | 6 | 7   | 8 | 9 | 10 | 11 | 12 | 13 | 14 | 15 |
| b <sub>3</sub> | b <sub>2</sub> | b <sub>1</sub> | b <sub>0</sub> |                |     |     |    |   |   |   |   |     |   |   |    |    |    |    |    |    |
| 0              | 0              | 0              | 0              | 0              | NUL | DLE | SP | 0 | @ | P | ' | p   |   |   |    | —  | â  | Å  | Á  | Æ  |
| 0              | 0              | 0              | 1              | 1              | SOH | DC1 | !  | 1 | A | Q | a | q   |   |   |    | À  | ê  | î  | Ã  | þ  |
| 0              | 0              | 1              | 0              | 2              | STX | DC2 | "  | 2 | B | R | b | r   |   |   |    | Â  | ô  | ø  | ã  |    |
| 0              | 0              | 1              | 1              | 3              | ETX | DC3 | #  | 3 | C | S | c | s   |   |   |    | É  | °  | û  | Æ  | Ð  |
| 0              | 1              | 0              | 0              | 4              | EOT | DC4 | \$ | 4 | D | T | d | t   |   |   |    | Ê  | ç  | á  | å  | đ  |
| 0              | 1              | 0              | 1              | 5              | ENQ | NAK | %  | 5 | E | U | e | u   |   |   |    | Ë  | ç  | é  | í  | Ï  |
| 0              | 1              | 1              | 0              | 6              | ACK | SYN | &  | 6 | F | V | f | v   |   |   |    | Î  | Ñ  | ó  | ø  | Ï  |
| 0              | 1              | 1              | 1              | 7              | BEL | ETB | '  | 7 | G | W | g | w   |   |   |    | Ï  | ñ  | ú  | æ  | Ó  |
| 1              | 0              | 0              | 0              | 8              | BS  | CAN | (  | 8 | H | X | h | x   |   |   |    |    | í  | à  | À  | Ô  |
| 1              | 0              | 0              | 1              | 9              | HT  | EM  | )  | 9 | I | Y | i | y   |   |   |    |    | ì  | è  | ì  | Õ  |
| 1              | 0              | 1              | 0              | 10             | LF  | SUB | *  | : | J | Z | j | z   |   |   |    | ^  | Ï  | ò  | Ö  | ö  |
| 1              | 0              | 1              | 1              | 11             | VT  | ESC | +  | ; | K | [ | k | {   |   |   |    | ˆ  | Ï  | û  | Ü  | Š  |
| 1              | 1              | 0              | 0              | 12             | FF  | FS  | ,  | < | L | \ | l |     |   |   |    | ˆ  | Ï  | ä  | É  | š  |
| 1              | 1              | 0              | 1              | 13             | CR  | GS  | .  | = | M | ] | m | }   |   |   |    | ˆ  | Ï  | é  | ï  | Ú  |
| 1              | 1              | 1              | 0              | 14             | SO  | RS  | .  | > | N | ^ | n | ~   |   |   |    | ˆ  | Ï  | ö  | ß  | ÿ  |
| 1              | 1              | 1              | 1              | 15             | SI  | US  | /  | ? | O | _ | o | DEL |   |   |    | ˆ  | Ï  | ü  | Ö  | ÿ  |

| Graphic | Hex | Dec | Oct | Description                     |
|---------|-----|-----|-----|---------------------------------|
|         | 00  | 0   | 000 | NUL (null)                      |
|         | 01  | 1   | 001 | SOH (start of heading)          |
|         | 02  | 2   | 002 | STX (start of text)             |
|         | 03  | 3   | 003 | ETX (end of text)               |
|         | 04  | 4   | 004 | EOT (end of transmission)       |
|         | 05  | 5   | 005 | ENQ (enquiry)                   |
|         | 06  | 6   | 006 | ACK (acknowledge)               |
|         | 07  | 7   | 007 | BEL (bell)                      |
|         | 08  | 8   | 010 | BS (backspace)                  |
|         | 09  | 9   | 011 | HT (horizontal tabulation)      |
|         | 0A  | 10  | 012 | LF (line feed)                  |
|         | 0B  | 11  | 013 | VT (vertical tabulation)        |
|         | 0C  | 12  | 014 | FF (form feed)                  |
|         | 0D  | 13  | 015 | CR (carriage return)            |
|         | 0E  | 14  | 016 | SO (shift out)                  |
|         | 0F  | 15  | 017 | SI (shift in)                   |
|         | 10  | 16  | 020 | DLE (data link escape)          |
|         | 11  | 17  | 021 | DC1 (device control 1 or X-ON)  |
|         | 12  | 18  | 022 | DC2 (device control 2)          |
|         | 13  | 19  | 023 | DC3 (device control 3 or X-OFF) |
|         | 14  | 20  | 024 | DC4 (device control 4)          |
|         | 15  | 21  | 025 | NAK (negative acknowledge)      |
|         | 16  | 22  | 026 | SYN (synchronous idle)          |
|         | 17  | 23  | 027 | ETB (end of transmission block) |
|         | 18  | 24  | 030 | CAN (cancel)                    |
|         | 19  | 25  | 031 | EM (end of medium)              |
|         | 1A  | 26  | 032 | SUB (substitute)                |
|         | 1B  | 27  | 033 | ESC (escape)                    |
|         | 1C  | 28  | 034 | FS (file separator)             |
|         | 1D  | 29  | 035 | GS (group separator)            |
|         | 1E  | 30  | 036 | RS (record separator)           |
|         | 1F  | 31  | 037 | US (unit separator)             |
|         | 20  | 32  | 040 | Space                           |
| !       | 21  | 33  | 041 | Exclamation point               |
| "       | 22  | 34  | 042 | Quotation mark                  |
| #       | 23  | 35  | 043 | Number sign (hash mark)         |

| Graphic | Hex | Dec | Oct | Description                       |
|---------|-----|-----|-----|-----------------------------------|
| \$      | 24  | 36  | 044 | Dollar sign                       |
| %       | 25  | 37  | 045 | Percent sign                      |
| &       | 26  | 38  | 046 | Ampersand                         |
| '       | 27  | 39  | 047 | Apostrophe (closing single quote) |
| (       | 28  | 40  | 050 | Opening parenthesis               |
| )       | 29  | 41  | 051 | Closing parenthesis               |
| *       | 2A  | 42  | 052 | Asterisk                          |
| +       | 2B  | 43  | 053 | Plus                              |
| ,       | 2C  | 44  | 054 | Comma                             |
| -       | 2D  | 45  | 055 | Hyphen (minus)                    |
| .       | 2E  | 46  | 056 | Period (point)                    |
| /       | 2F  | 47  | 057 | Slant (solidus)                   |
| 0       | 30  | 48  | 060 | Zero                              |
| 1       | 31  | 49  | 061 | One                               |
| 2       | 32  | 50  | 062 | Two                               |
| 3       | 33  | 51  | 063 | Three                             |
| 4       | 34  | 52  | 064 | Four                              |
| 5       | 35  | 53  | 065 | Five                              |
| 6       | 36  | 54  | 066 | Six                               |
| 7       | 37  | 55  | 067 | Seven                             |
| 8       | 38  | 56  | 070 | Eight                             |
| 9       | 39  | 57  | 071 | Nine                              |
| :       | 3A  | 58  | 072 | Colon                             |
| ;       | 3B  | 59  | 073 | Semicolon                         |
| <       | 3C  | 60  | 074 | Less than sign                    |
| =       | 3D  | 61  | 075 | Equal sign                        |
| >       | 3E  | 62  | 076 | Greater than sign                 |
| ?       | 3F  | 63  | 077 | Question mark                     |
| @       | 40  | 64  | 100 | Commercial at                     |
| A       | 41  | 65  | 101 | Uppercase A                       |
| B       | 42  | 66  | 102 | Uppercase B                       |
| C       | 43  | 67  | 103 | Uppercase C                       |
| D       | 44  | 68  | 104 | Uppercase D                       |
| E       | 45  | 69  | 105 | Uppercase E                       |
| F       | 46  | 70  | 106 | Uppercase F                       |
| G       | 47  | 71  | 107 | Uppercase G                       |



| Graphic | Hex | Dec | Oct | Description            |
|---------|-----|-----|-----|------------------------|
| H       | 48  | 72  | 110 | Uppercase H            |
| I       | 49  | 73  | 111 | Uppercase I            |
| J       | 4A  | 74  | 112 | Uppercase J            |
| K       | 4B  | 75  | 113 | Uppercase K            |
| L       | 4C  | 76  | 114 | Uppercase L            |
| M       | 4D  | 77  | 115 | Uppercase M            |
| N       | 4E  | 78  | 116 | Uppercase N            |
| O       | 4F  | 79  | 117 | Uppercase O            |
| P       | 50  | 80  | 120 | Uppercase P            |
| Q       | 51  | 81  | 121 | Uppercase Q            |
| R       | 52  | 82  | 122 | Uppercase R            |
| S       | 53  | 83  | 123 | Uppercase S            |
| T       | 54  | 84  | 124 | Uppercase T            |
| U       | 55  | 85  | 125 | Uppercase U            |
| V       | 56  | 86  | 126 | Uppercase V            |
| W       | 57  | 87  | 127 | Uppercase W            |
| X       | 58  | 88  | 130 | Uppercase X            |
| Y       | 59  | 89  | 131 | Uppercase Y            |
| Z       | 5A  | 90  | 132 | Uppercase Z            |
| [       | 5B  | 91  | 133 | Opening square bracket |
| \       | 5C  | 92  | 134 | Reverse slant          |
| ]       | 5D  | 93  | 135 | Closing square bracket |
| ^       | 5E  | 94  | 136 | Caret (circumflex)     |
| _       | 5F  | 95  | 137 | Underscore (low line)  |
| '       | 60  | 96  | 140 | Opening single quote   |
| a       | 61  | 97  | 141 | Lowercase a            |
| b       | 62  | 98  | 142 | Lowercase b            |
| c       | 63  | 99  | 143 | Lowercase c            |
| d       | 64  | 100 | 144 | Lowercase d            |
| e       | 65  | 101 | 145 | Lowercase e            |
| f       | 66  | 102 | 146 | Lowercase f            |
| g       | 67  | 103 | 147 | Lowercase g            |
| h       | 68  | 104 | 150 | Lowercase h            |
| i       | 69  | 105 | 151 | Lowercase i            |
| j       | 6A  | 106 | 152 | Lowercase j            |
| k       | 6B  | 107 | 153 | Lowercase k            |
| l       | 6C  | 108 | 154 | Lowercase l            |
| m       | 6D  | 109 | 155 | Lowercase m            |
| n       | 6E  | 110 | 156 | Lowercase n            |
| o       | 6F  | 111 | 157 | Lowercase o            |



| Graphic | Hex | Dec | Oct | Description                   |
|---------|-----|-----|-----|-------------------------------|
| p       | 70  | 112 | 160 | Lowercase p                   |
| q       | 71  | 113 | 161 | Lowercase q                   |
| r       | 72  | 114 | 162 | Lowercase r                   |
| s       | 73  | 115 | 163 | Lowercase s                   |
| t       | 74  | 116 | 164 | Lowercase t                   |
| u       | 75  | 117 | 165 | Lowercase u                   |
| v       | 76  | 118 | 166 | Lowercase v                   |
| w       | 77  | 119 | 167 | Lowercase w                   |
| x       | 78  | 120 | 170 | Lowercase x                   |
| y       | 79  | 121 | 171 | Lowercase y                   |
| z       | 7A  | 122 | 172 | Lowercase z                   |
| {       | 7B  | 123 | 173 | Opening brace (curly bracket) |
|         | 7C  | 124 | 174 | Vertical line                 |
| }       | 7D  | 125 | 175 | Closing brace (curly bracket) |
| ~       | 7E  | 126 | 176 | Tilde                         |
| ■       | 7F  | 127 | 177 | Delete (rubout)               |
|         | 80  | 128 | 200 | --undefined control code--    |
|         | 81  | 129 | 201 | --undefined control code--    |
|         | 82  | 130 | 202 | --undefined control code--    |
|         | 83  | 131 | 203 | --undefined control code--    |
|         | 84  | 132 | 204 | --undefined control code--    |
|         | 85  | 133 | 205 | --undefined control code--    |
|         | 86  | 134 | 206 | --undefined control code--    |
|         | 87  | 135 | 207 | --undefined control code--    |
|         | 88  | 136 | 210 | --undefined control code--    |
|         | 89  | 137 | 211 | --undefined control code--    |
|         | 8A  | 138 | 212 | --undefined control code--    |
|         | 8B  | 139 | 213 | --undefined control code--    |
|         | 8C  | 140 | 214 | --undefined control code--    |
|         | 8D  | 141 | 215 | --undefined control code--    |
|         | 8E  | 142 | 216 | --undefined control code--    |
|         | 8F  | 143 | 217 | --undefined control code--    |
|         | 90  | 144 | 220 | --undefined control code--    |
|         | 91  | 145 | 221 | --undefined control code--    |
|         | 92  | 146 | 222 | --undefined control code--    |
|         | 93  | 147 | 223 | --undefined control code--    |
|         | 94  | 148 | 224 | --undefined control code--    |
|         | 95  | 149 | 225 | --undefined control code--    |
|         | 96  | 150 | 226 | --undefined control code--    |
|         | 97  | 151 | 227 | --undefined control code--    |

| Graphic | Hex | Dec | Oct | Description                     |
|---------|-----|-----|-----|---------------------------------|
|         | 98  | 152 | 230 | --undefined control code--      |
|         | 99  | 153 | 231 | --undefined control code--      |
|         | 9A  | 154 | 232 | --undefined control code--      |
|         | 9B  | 155 | 233 | --undefined control code--      |
|         | 9C  | 156 | 234 | --undefined control code--      |
|         | 9D  | 157 | 235 | --undefined control code--      |
|         | 9E  | 158 | 236 | --undefined control code--      |
|         | 9F  | 159 | 237 | --undefined control code--      |
|         | A0  | 160 | 240 | --undefined--                   |
| À       | A1  | 161 | 241 | Uppercase A grave accent        |
| Á       | A2  | 162 | 242 | Uppercase A circumflex          |
| Ê       | A3  | 163 | 243 | Uppercase E grave accent        |
| Ë       | A4  | 164 | 244 | Uppercase E circumflex          |
| Ë       | A5  | 165 | 245 | Uppercase E umlaut or diaeresis |
| Ï       | A6  | 166 | 246 | Uppercase I circumflex          |
| Ï       | A7  | 167 | 247 | Uppercase I umlaut or diaeresis |
| ˘       | A8  | 168 | 250 | Acute accent                    |
| ˘       | A9  | 169 | 251 | Grave accent                    |
| ˘       | AA  | 170 | 252 | Circumflex accent               |
| ˘       | AB  | 171 | 253 | Umlaut (diaeresis) accent       |
| ˘       | AC  | 172 | 254 | Tilde accent                    |
| Û       | AD  | 173 | 255 | Uppercase U grave accent        |
| Û       | AE  | 174 | 256 | Uppercase U circumflex          |
| ₣       | AF  | 175 | 257 | Italian Lira symbol             |
| —       | B0  | 176 | 260 | Over line (high line)           |
|         | B1  | 177 | 261 | --undefined--                   |
|         | B2  | 178 | 262 | --undefined--                   |
| °       | B3  | 179 | 263 | Degree (ring)                   |
| Ç       | B4  | 180 | 264 | Uppercase C cedilla             |
| ç       | B5  | 181 | 265 | Lowercase c cedilla             |
| Ñ       | B6  | 182 | 266 | Uppercase N tilde               |
| ñ       | B7  | 183 | 267 | Lowercase n tilde               |
| ¡       | B8  | 184 | 270 | Inverse exclamation mark        |
| ¿       | B9  | 185 | 271 | Inverse question mark           |
| ₧       | BA  | 186 | 272 | General currency symbol         |
| £       | BB  | 187 | 273 | British pound sign              |
| ¥       | BC  | 188 | 274 | Japanese yen symbol             |

| Graphic | Hex | Dec | Oct | Description                     |
|---------|-----|-----|-----|---------------------------------|
| §       | BD  | 189 | 275 | Section sign                    |
| ƒ       | BE  | 190 | 276 | Dutch guilder symbol            |
| ¢       | BF  | 191 | 277 | U.S. cent symbol                |
| â       | C0  | 192 | 300 | Lowercase a circumflex          |
| ê       | C1  | 193 | 301 | Lowercase e circumflex          |
| ô       | C2  | 194 | 302 | Lowercase o circumflex          |
| û       | C3  | 195 | 303 | Lowercase u circumflex          |
| á       | C4  | 196 | 304 | Lowercase a acute accent        |
| é       | C5  | 197 | 305 | Lowercase e acute accent        |
| ó       | C6  | 198 | 306 | Lowercase o acute accent        |
| ú       | C7  | 199 | 307 | Lowercase u acute accent        |
| à       | C8  | 200 | 310 | Lowercase a grave accent        |
| è       | C9  | 201 | 311 | Lowercase e grave accent        |
| ò       | CA  | 202 | 312 | Lowercase o grave accent        |
| ù       | CB  | 203 | 313 | Lowercase u grave accent        |
| ä       | CC  | 204 | 314 | Lowercase a umlaut or diaeresis |
| ë       | CD  | 205 | 315 | Lowercase e umlaut or diaeresis |
| ö       | CE  | 206 | 316 | Lowercase o umlaut or diaeresis |
| ü       | CF  | 207 | 317 | Lowercase u umlaut or diaeresis |
| Á       | D0  | 208 | 320 | Uppercase A degree              |
| í       | D1  | 209 | 321 | Lowercase i circumflex          |
| Ø       | D2  | 210 | 322 | Uppercase O crossbar            |
| Æ       | D3  | 211 | 323 | Uppercase AE ligature           |
| â       | D4  | 212 | 324 | Lowercase a degree              |
| ï       | D5  | 213 | 325 | Lowercase i acute accent        |
| ø       | D6  | 214 | 326 | Lowercase o crossbar            |
| æ       | D7  | 215 | 327 | Lowercase æ ligature            |
| Ä       | D8  | 216 | 330 | Uppercase A umlaut or diaeresis |
| ì       | D9  | 217 | 331 | Lowercase i grave accent        |
| Ö       | DA  | 218 | 332 | Uppercase O umlaut or diaeresis |
| Û       | DB  | 219 | 333 | Uppercase U umlaut or diaeresis |
| È       | DC  | 220 | 334 | Uppercase E acute accent        |
| ï       | DD  | 221 | 335 | Lowercase i umlaut or           |

| Graphic | Hex | Dec | Oct | Description                          |
|---------|-----|-----|-----|--------------------------------------|
| ß       | DE  | 222 | 336 | diaeresis                            |
| Ô       | DF  | 223 | 337 | Sharp s<br>Uppercase O circumflex    |
| Á       | E0  | 224 | 340 | Uppercase A acute accent             |
| Ã       | E1  | 225 | 341 | Uppercase A tilde                    |
| ã       | E2  | 226 | 342 | Lowercase a tilde                    |
| Ð       | E3  | 227 | 343 | Uppercase D with stroke              |
| ð       | E4  | 228 | 344 | Lowercase d with stroke              |
| Í       | E5  | 229 | 345 | Uppercase I acute accent             |
| í       | E6  | 230 | 346 | Uppercase I grave accent             |
| Ó       | E7  | 231 | 347 | Uppercase O acute accent             |
| Ò       | E8  | 232 | 350 | Uppercase O grave accent             |
| Ô       | E9  | 233 | 351 | Uppercase O tilde                    |
| õ       | EA  | 234 | 352 | Lowercase o tilde                    |
| Š       | EB  | 235 | 353 | Uppercase S with caron               |
| š       | EC  | 236 | 354 | Lowercase s with caron               |
| Û       | ED  | 237 | 355 | Uppercase U acute accent             |
| Û       | EE  | 238 | 356 | Uppercase Y umlaut or<br>diaeresis   |
| ÿ       | EF  | 239 | 357 | Lowercase y umlaut or<br>diaeresis   |
| Þ       | F0  | 240 | 360 | Uppercase Thorn                      |
| þ       | F1  | 241 | 361 | Lowercase thorn                      |
|         | F2  | 242 | 362 | --undefined--                        |
|         | F3  | 243 | 363 | --undefined--                        |
|         | F4  | 244 | 364 | --undefined--                        |
|         | F5  | 245 | 365 | --undefined--                        |
| -       | F6  | 246 | 366 | Long dash (horizontal bar)           |
| ¼       | F7  | 247 | 367 | One fourth (one quarter)             |
| ½       | F8  | 248 | 370 | One half                             |
| ª       | F9  | 249 | 371 | Feminine ordinal indicator           |
| º       | FA  | 250 | 372 | Masculine ordinal indicator          |
| «       | FB  | 251 | 373 | Opening guillemets (angle<br>quotes) |
| ■       | FC  | 252 | 374 | Solid                                |
| »       | FD  | 253 | 375 | Closing guillemets (angle<br>quotes) |
| ±       | FE  | 254 | 376 | Plus minus sign                      |
|         | FF  | 255 | 377 | --undefined--                        |

---

## Appendix C

---

---

# SWITCHING RS-232C/RS-422 INTERFACES AND BAUD RATE

---

When switching between the RS-232C interface and the RS-422 interface, or when changing the baud rate, the back cover of the printer must be removed and some jumpers and/or switches must be configured. NOTE: A parallel interface is also available with LaserJet<sup>+</sup> or LaserJet 500<sup>+</sup> printers--see Appendix D for configuration information.

If you have a LaserJet<sup>+</sup> or LaserJet 500<sup>+</sup> printer, see the "LaserJet<sup>+</sup>/LaserJet 500<sup>+</sup> Information" discussion at the end of this appendix.

---

### **WARNING**

Removing the rear panel may expose hazardous voltages in printers with a serial number prior to #2414J01807. Locate the serial number of the printer on the ID label to the left of the AC power cord. If your printer has a serial number smaller than #2414J01807, call your HP Sales and Service Office concerning switching interfaces or changing baud rate.

---

# Switching Interfaces (RS-232C/RS-422)

To switch interfaces from an RS-232C to an RS-422 (or vice versa), perform the following steps (this process is the same for all LaserJet family printers):

- a. Switch the printer power to the OFF (0) position and unplug the AC power cord from the AC outlet.
- b. Remove the rear panel of the printer by removing the four screws as shown below.

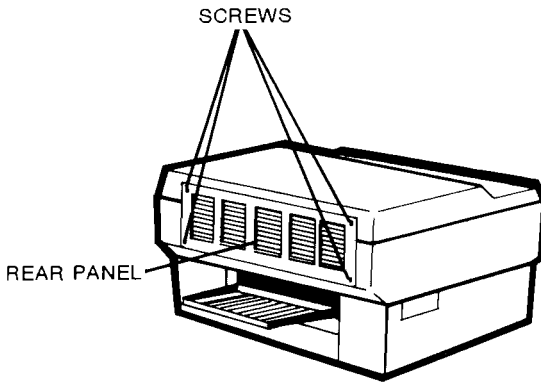

- c. Set the jumper sockets of JP2 to the positions shown in the following illustration.

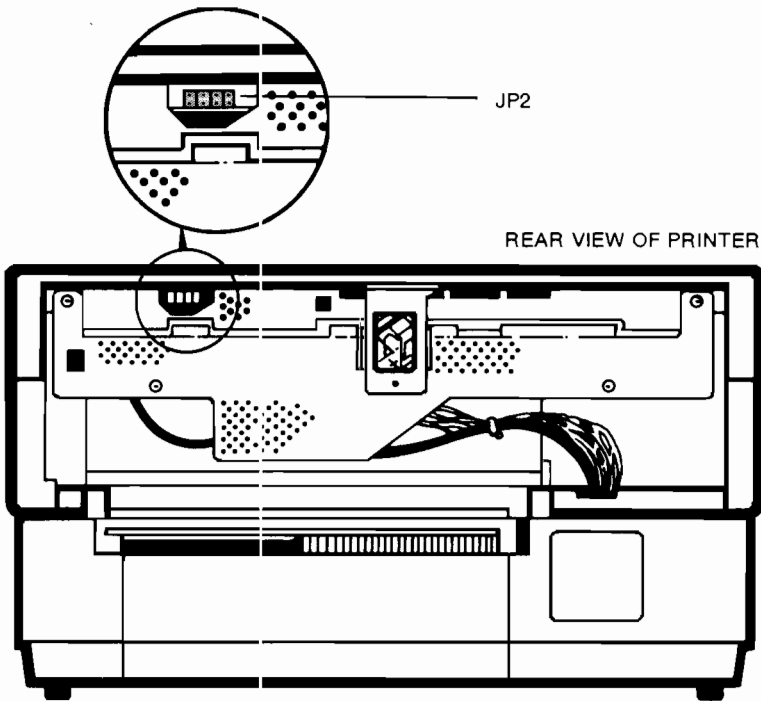

RS-232

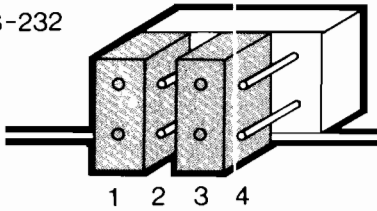

RS-422

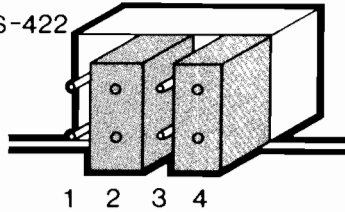

- d. Replace the rear panel with the four screws removed in step b.
- e. Plug in the power cord and switch the power to the ON (I) position. The printer will then be ready for use.

# Changing Baud Rate

The printer's baud rate when shipped is set at 9600. To change the baud rate, perform the following steps (this process is the same for all LaserJet family printers):

- a. Switch the printer power to the OFF (0) position and remove the AC power cord from the AC outlet.
- b. Remove the rear panel by removing the four screws as shown below.

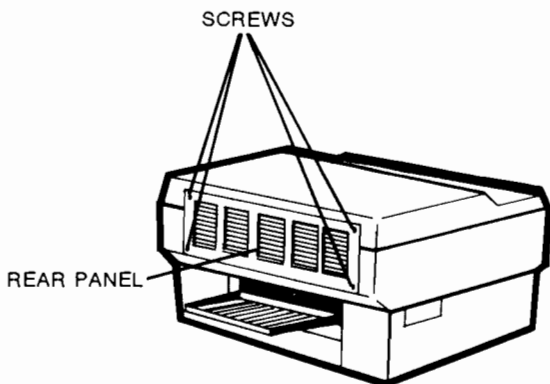



- c. Remove the vertical support bracket (1 screw) at the center of the cabinet as shown below.

REAR VIEW OF PRINTER

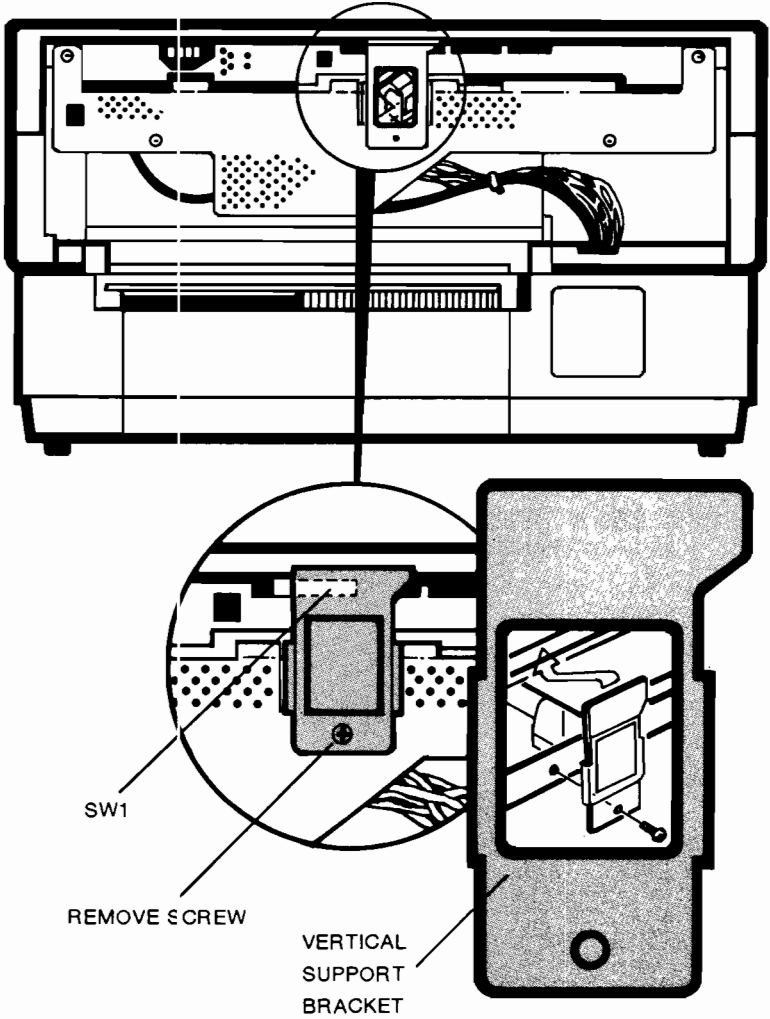

- d. Switch the SW1 switches (2, 3, and 4) to the desired baud rate by consulting the table below:

| Switch Number |     |     | Baud Rate |
|---------------|-----|-----|-----------|
| 2             | 3   | 4   |           |
| OFF           | OFF | OFF | 300       |
| OFF           | OFF | ON  | 600       |
| OFF           | ON  | OFF | 1200      |
| OFF           | ON  | ON  | 2400      |
| ON            | OFF | OFF | 4800      |
| ON            | OFF | ON  | 9600      |
| ON            | ON  | OFF | 19200     |

---

**NOTE**

SW1 is set at the factory as follows: 1--OFF, 2--ON, 3--OFF, 4--ON, 5--OFF 6--OFF, 7--OFF, 8--ON.

Position 8 of switch SW1 is the Data Terminal Ready (DTR) bit of the RS-232C configuration. The printer is shipped from the factory with this switch set to the ON position (active high). The signal polarity of this switch can be inverted (active low) by setting the switch to the OFF position.

For the **LaserJet** printer, switch positions 1, 5, and 6 serve no function and are normally set to the OFF position. (See the "**LaserJet<sup>+</sup>/LaserJet 500<sup>+</sup>** Information discussion to find out how the SW1 switches function for these printers.) Switch number 7 is used only for the **LaserJet 500<sup>+</sup>** printers (see "Configuring Auto-Select Mode Power-On State" in Chapter 4).

- 
- e. Replace the vertical support bracket removed in step c.
- f. Replace the rear panel with the four screws removed in step b.

- g. Plug in the AC power cord, switch the printer's power ON (1), and resume operation. Remember that the computer system and the printer must be set to the same baud rate for proper operation.

## **LaserJet+/LaserJet 500+ Information**

If you have a **LaserJet+** or **LaserJet 500+** printer, there are a few switch settings that may be of interest to you. These printers provide an auto-continue mode and may also be used with a parallel interface. (The parallel interface configuration is discussed in Appendix D.)

### **SELECTING AUTO-CONTINUE MODE**

When print and data errors (error numbers 20, 21, 22, 40, and 41) occur, the printer normally pauses until the CONTINUE key is pressed. If you wish to have the printer automatically continue without operator intervention (after the error number flashes about 10 times), set switch 5 of SW1 to the ON position (SW1 is accessed by following the "Changing Baud Rate" discussion in this appendix, replacing step d. with "Set switch 5 of SW1 to the ON position.").

The following table lists the **LaserJet+/LaserJet 500+** SW1 switches and explains what each position indicates.



TABLE C-1. LASERJET <sup>+</sup>/LASERJET 500<sup>+</sup>  
SW1 SWITCH SETTINGS

| SWITCH # | USE  | ON  | OFF   |
|----------|--|---|---|
| 1        | I/O TYPE   | Parallel  | Serial RS-232C/422  |
| 2 - 4    | BAUD RATE  | (same as LaserJet)  |   |
| 5        | AUTO-CONTINUE  | Continue on print and data errors after flashing 10 times   | Flash error until operator presses the CONTINUE key (factory setting) |
| 6        | ROBUST X-ON  | X-ons repeated every 1 second when printer is waiting for data but none is being sent (same as standard LaserJet) (factory setting) | Only 1 X-on sent when printer needs more print data                   |
| 7        | AUTO-SELECT MODE (for LaserJet 500 <sup>+</sup> printers only) | Powers-up in Auto-Select mode   | Powers-up with Auto-Select mode off                                   |
| 8        | DTR POLARITY   | DTR pin 20 high when printer ready (factory setting)  | DTR pin 20 low when printer ready                                     |

---

# Appendix D

---

---

## INTERFACE CONFIGURATION AND CABLE PIN ASSIGNMENTS

---

---

### Introduction

This appendix provides general information for configuring your computer to the LaserJet printer family. The LaserJet family of printers communicates using either the RS-232C/RS-422 serial interface or the parallel interface (the parallel interface is only available with the LaserJet<sup>+</sup> and LaserJet 500<sup>+</sup> printers). This appendix provides general instructions for configuring your computer to the LaserJet family of printers using either interface. (Specific serial interface configuration information for the IBM PC, HP 150 and several other personal computers is contained in the LaserJet Operator's Manual [part no. 02686-90914] or LaserJet 500+ Operator's Manual [02868-90911].) Cable pin assignments are also specified in this appendix for both the serial and parallel interfaces.

This chapter contains the following information:

|  |     |
|--|-----|
| Serial Interface Configuration . . . . .       | D-2 |
| Serial Interface Selection . . . . .           | D-2 |
| Signal Protocol Selection . . . . .            | D-2 |
| Cabling . . . . .                              | D-3 |
| CPU Configuration . . . . .                    | D-4 |
| Testing the Serial I/O Configuration . . . . . | D-4 |
| Parallel Interface Configuration. . . . .      | D-5 |

|  |      |
|--|------|
| Required Hardware . . . . .                      | D-5  |
| PC-to-Printer Cabling . . . . .                  | D-6  |
| Installation . . . . .                           | D-8  |
| Selecting the Parallel I/O . . . . .             | D-8  |
| Configuration . . . . .                          | D-9  |
| Testing the Parallel I/O Configuration . . . . . | D-10 |

## Serial Interface Configuration

The serial interface configuration procedure consists of the following five steps:

1. Serial Interface Selection
2. Signal Protocol Selection
3. Cabling
4. CPU Configuration
5. Testing the Serial Interface Configuration

### SERIAL INTERFACE SELECTION

The printer is configured with an RS-232C interface when it is shipped, but it may also be configured with an RS-422 interface by performing the "Switching Interfaces" procedure in appendix C of this manual.

### SIGNAL PROTOCOL SELECTION

It is important to remember that RS-232C is not a standard, but is a set of guidelines. Therefore, there are several popular implementations of RS-232C. The communication protocols (or handshakes) that are supported on the LaserJet printer family are X-on/X-off and DTR (hardware handshake). The LaserJet printer family does not support Enq/Ack protocol. Therefore, if your computer only supports Enq/Ack protocol, you will probably not be able to communicate with the printer.

Since the printers can only use X-on/X-off protocol or hardware handshake, you must decide which of these two protocols you wish to use and configure your computer to communicate using the chosen protocol.

## CABLING

The RS-232C interface connector on the printer is a standard 25-pin female connector. This requires that the printer end of the interface cable has a male connector (see the following figure for a connector diagram).

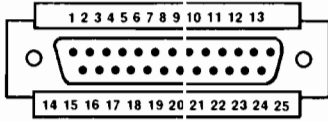

25-PIN FEMALE  
CONNECTOR (LaserJet)

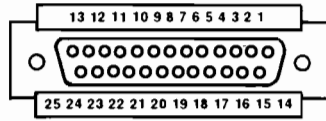

25-PIN MALE  
CONNECTOR

Of the 25 pins in the connector, the printer only utilizes those listed in the following table. Using the pinout diagram listed below and the pinout diagram for your computer, obtain a compatible cable (taking into consideration the protocol to be used). **NOTE:** The pin defined as transmit data (TD) from the computer must go to receive data (RD--pin 3) of the printer and the pin defined as receive data (RD) from the computer must go to transmit data (TD--pin 2) on the printer.

| PIN<br>NUMBERS | DESCRIPTION                             | SIGNALS USED      |                  |        |
|----------------|---|-------------------|------------------|--------|
|                |   | RS-232C<br>(X-on) | RS-232C<br>(DTR) | RS-422 |
| 1              | FG--Frame Ground                        | X                 | X                | X      |
| 2              | TD--Transmitted Data<br>to the computer | X                 | X                |        |
| 3              | RD--Received Data<br>from the computer  | X                 | X                | X      |
| 7              | SG--Signal Ground                       | X                 | X                | X      |
| 9              | SDA--Send Data                          |                   |                  | X      |
| 10             | SDB--Not Send Data                      |                   |                  | X      |
| 18             | RDB--Not Received Data                  |                   |                  | X      |
| 20             | DTR--Data Terminal<br>Ready             |                   | X                |        |

## CPU CONFIGURATION

Once the correct cable is connected between the computer (CPU) and the printer, the computer's port must be configured for the printer. The configuration should be set to the following parameters:

Start Bits – 1  
Data Bits – 8  
Stop Bits – 1  
Parity – None  
Baud Rate – 9600 or desired baud

Except for the baud rate, none of the above parameters may be changed in the configuration. If, however, you desire to change the baud rate, perform the "Changing Baud Rate" procedure in Appendix C of this manual.

## TESTING THE SERIAL INTERFACE CONFIGURATION

Verify successful communication by running the following BASIC program (or any other simple print test):

```
10 LPRINT CHR$(27);"E";      'RESETS PRINTER
20 LPRINT "LASERJET COMMUNICATION OK"
30 LPRINT CHR$(13);         'CARRIAGE RETURN
40 LPRINT CHR$(12);         'FORM FEED
50 END
```

Execute the program by entering RUN. The printer will print "LASERJET COMMUNICATION OK".

If there is no communication, check the following:

- Ensure that the printer is on-line
- Ensure that the printer is working properly by performing a self-test and printing a TEST PRINT
- Ensure that the computer is working properly by running an application program that you have used successfully in the past



Ensure that the computer's port is working properly by running another peripheral from the same port

Ensure that the interface cable is seated properly at both ends

Ensure that the cable used has pin assignments that correspond to the pinout diagrams for the LaserJet family printer and your computer.

## Parallel Interface Configuration

The use of the parallel interface provides three advantages over using the serial interface:

- a. Data transfer for raster graphics is significantly faster and transfer of font data is somewhat faster.
- b. Installation and configuration requires virtually no knowledge of computer hardware interfacing concepts.
- c. The printer does not use one of the computer's serial ports, which frees a serial port for either data communications use or for use with another peripheral.

Disadvantages of using the parallel interface are that the required cable is much more difficult to build and that the cable must be no longer than 10 feet. (Additionally, if you are using an HP 150 Touchscreen personal computer, the Shift-Print Screen screen-dump function will not operate. If the screen-dump feature is needed, use the RS-232C or RS-422 interface.)

### REQUIRED HARDWARE

To use the LaserJet parallel interface, the computer system must be equipped with a corresponding parallel interface. As of this writing, the IBM PC comes standard with a parallel interface. The HP 150 Touchscreen Personal Computer is not supplied standard with a parallel interface, but the interface may be purchased separately (contact your HP Dealer). An interface cable is also required as described in the following discussion.

The parallel interface configuration procedure consists of the following steps:

1. PC-to-Printer Cabling
2. Installation
3. Selecting the Parallel Interface
4. Configuration
5. Testing the Configuration

## PC-TO-PRINTER CABLING

Unlike the cable for serial interfaces, the required parallel interface cable is difficult to build. There are several reasons for this: the printer connectors are not as readily available as the serial connectors, over 20 solder connections must be made on each side of the cable, and improperly constructed cables can generate significant levels of RFI (Radio Frequency Interference). (To reduce RFI, the cable must be assembled with the wires wrapped in twisted pairs.) For these reasons, it is recommended that only technical professionals attempt to make their own cables. Both HP and IBM supply properly-built parallel interface cables, as do many other manufacturers. HP cables are guaranteed to operate properly and have been tested to ensure that RFI levels are within legal limits. The following three parallel interface cables are available from Hewlett-Packard's Direct Marketing Division (call toll free: 800-538-8787 [in California call 408-738-4133 collect] ) :

- 13242D -- 6.6-foot (2 meter) Male-to-Female HP 150 Cable
- 92219K -- 9-foot (2.3 meter) Male-to-Male IBM PC/XT and PC/AT Cable
- 24542D -- 6.6-foot (2 meter) Male-to-Male IBM PC/XT and PC/AT Cable (Available from HP Sales & Service Offices Only)

The cabling information on the following pages is provided for those who are willing and able to make their own cables.

## LASERJET-TO-IBM CABLE PIN ASSIGNMENTS

| Signal Name | LaserJet Pin #<br>(Amphenol 57-30360) | IBM Port Pin #<br>(Amphenol 117DB25P) |
|-------------|---------------------------------------|---------------------------------------|
| nSTROBE     | 1                                     | 1                                     |
| DATA1       | 2                                     | 2                                     |
| DATA2       | 3                                     | 3                                     |
| DATA3       | 4                                     | 4                                     |
| DATA4       | 5                                     | 5                                     |
| DATA5       | 6                                     | 6                                     |
| DATA6       | 7                                     | 7                                     |
| DATA7       | 8                                     | 8                                     |
| DATA8       | 9                                     | 9                                     |
| nACKNLG     | 10                                    | 10                                    |
| BUSY        | 11                                    | 11                                    |
| CALL (PE)   | 12                                    | 12                                    |
| SELECT      | 13                                    | 13                                    |
| nFAULT      | 32                                    | 15                                    |
| 0 VDC (GND) | 19 THRU 30                            | 18 THRU 25                            |

## LASERJET-TO-HP 150 CABLE PIN ASSIGNMENTS \*

| Signal Name | LaserJet Pin #<br>(Amphenol 57-30360) | HP Port Pin #<br>(Amphenol 117DB25S) |
|-------------|---------------------------------------|--------------------------------------|
| nSTROBE     | 1                                     | 1                                    |
| DATA1       | 2                                     | 2                                    |
| DATA2       | 3                                     | 3                                    |
| DATA3       | 4                                     | 4                                    |
| DATA4       | 5                                     | 5                                    |
| DATA5       | 6                                     | 6                                    |
| DATA6       | 7                                     | 7                                    |
| DATA7       | 8                                     | 8                                    |
| DATA8       | 9                                     | 9                                    |
| nACKNLG     | 10                                    | 10                                   |
| BUSY        | 11                                    | 11                                   |
| CALL (PE)   | 12                                    | 12                                   |
| SELECT      | 13                                    | 13                                   |
| nFAULT      | 32                                    | 15                                   |
| 0 VDC (GND) | 19 THRU 30                            | 18 THRU 25                           |

\* The only difference between the HP and the IBM cables is that the D-Subminiature connector for the IBM computer is a plug (male) and the connector for the HP 150 is a socket (female).

## INSTALLATION

If your computer has a parallel interface, installation is accomplished by simply connecting the proper cable between the computer and the printer. Connecting the cable to the right connector is easy since the printer and computer ends of the cable look very different from each other and the connectors are keyed to attach only to the correct connector.

## SELECTING THE PARALLEL INTERFACE

To select the parallel interface, switch number 1 of SW1 must be in the ON position. The OFF position indicates that an RS-232C or RS-422 interface is being used. Follow the instructions below to select the parallel interface:

---

### **WARNING**

Removing the rear panel may expose hazardous voltages in printers with a serial number prior to #2414J01807. Locate the serial number of the printer on the ID label to the left of the AC power cord. If your printer has a serial number smaller than #2414J01807, call your HP Sales and Service Office concerning switching interfaces or changing baud rate.

- 
- a. Switch the printer power to the OFF (0) position and remove the AC power cord from the AC outlet.

- b. Remove the rear panel by removing the four screws as shown below.

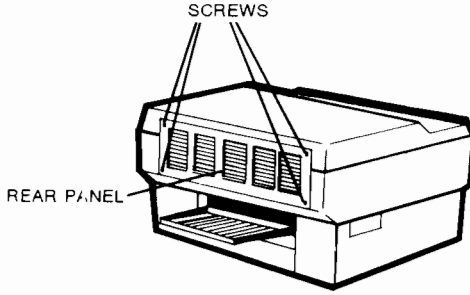

- c. Remove the vertical support bracket (1 screw) at the center of the cabinet as shown below.

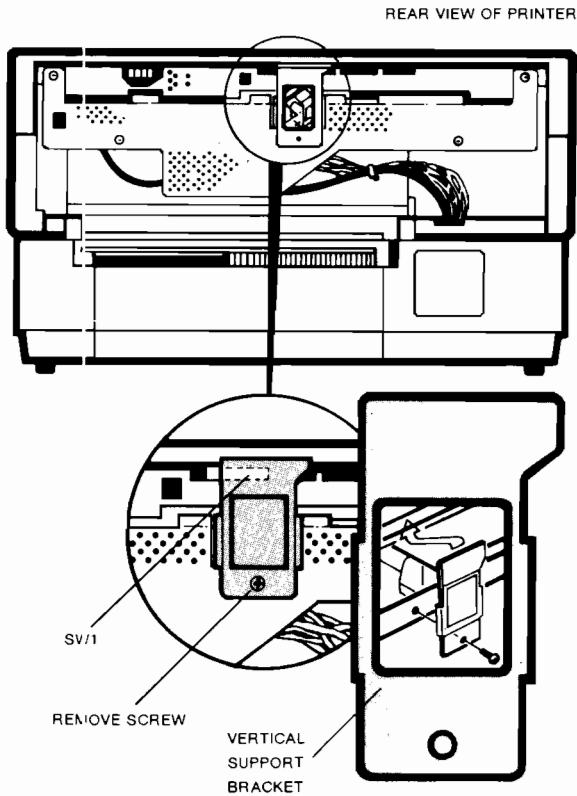

- d. Set switch number 1 of SW1 to the ON position to select the parallel interface.
- e. Replace the vertical support bracket removed in step c.
- f. Replace the rear panel with the four screws removed in step b.
- g. Plug in the AC power cord and switch the printer's power ON (1).

## CONFIGURATION

Once the interface cables are connected and the parallel interface is selected, check to make sure that the MS-DOS 'PRN' device is the parallel printer. Most computers automatically power-up with the 'PRN' device set up for the parallel port. If your computer system has been changed to use a serial port, you can redefine 'PRN' to the parallel port with the MS-DOS 'MODE' command. (If you are using an HP 150, use the EASY-CONFIG program to select the parallel printer as the 'PRN' device.)

As long as the parallel printer is set up as the 'PRN' device, no more configuration is required. Unlike the serial interface, which requires the user to set baud rates, number of data bits, stop bits, parity, polarity, handshake bit usage, and to specify a protocol, the parallel interface automatically takes care of these.

## TESTING THE PARALLEL INTERFACE CONFIGURATION

Verify successful communication by running the following BASIC program (or any other simple print test):

```
10 LPRINT CHR$(27);"E";          'RESETS PRINTER
20 LPRINT "LASERJET COMMUNICATION OK"
30 LPRINT CHR$(13);             'CARRIAGE RETURN
40 LPRINT CHR$(12);             'FORM FEED
50 END
```

Execute the program by entering RUN. The printer will print "LASERJET COMMUNICATION OK".

If there is no communication, check the following:

- Ensure that the printer is on-line
- Ensure that the printer is working properly by performing a self-test and printing a TEST PRINT
- Ensure that the computer is working properly by running an application program that you have used successfully in the past
- Ensure that the computer's port is working properly by running another peripheral from the same port
- Ensure that the interface cable is seated properly at both ends
- Ensure that the cable used has pin assignments that correspond to the pinout diagrams for the LaserJet family printer and your computer.





---

# GLOSSARY

---

## AUTO-SELECT MODE

Auto-Select mode is a **LaserJet 500+** printer feature that allows the printer to automatically begin printing with the other paper input cassette when the current cassette runs out of paper. Both paper input cassettes must have the same size paper loaded in order to automatically alternate cassettes. This feature is only selectable from the Operator Control Panel (no programmatic control). The printer is configured at the factory to power-up with the auto-select mode off, but the configuration can be changed so that it powers-up in the auto-select mode (see Chapter 4 and Appendix C).

## BAUD RATE

Baud rate is the rate of communication between the printer and the controlling computer/terminal. To communicate properly, the computer and the printer must both be configured at the same baud rate. All **LaserJet** family printers are configured at the factory for 9600 baud, but the baud rate may be changed to match the computer system by following the instructions in Appendix C.

## CURSOR

Although the printer does not actually have a cursor, the cursor position refers to the currently active printing position (similar to the blinking underline character [cursor] used on most computer terminals). In other words, the location of the "cursor" is the position on the paper where the next character will be printed. You can move the cursor to different points on the page using the cursor positioning escape sequences. For example, if the left margin is set to column 10 and you wish to print in column 2, you would send the `ESC#2C` escape sequence to the printer and

then send your text. This would cause the printer to begin printing your text at column 2.

## DECIPOINT

A decipoint is a unit of measurement that equals 1/720 of an inch. The **LaserJet** family printers have the capability of moving the cursor position in increments of 1/720 inch. For example, if you wish to move the cursor down two inches from where you are currently printing, you would send the `^c&a+1440V` escape sequence to the printer.

## DOWNLOADING

Downloading character fonts refers to the process of entering character font information from a disc font into the printer's memory. (Downloading character fonts is only possible with **LaserJet+** and **LaserJet 500+**.) Character fonts are downloaded from the disc to the printer so that they may be used for printing. When a font is downloaded to the printer, the printer's memory stores the dot-by-dot character information for each character of the font that is downloaded. (Single characters or entire fonts may be downloaded.) Once a font is downloaded, it can be selected just as if a font cartridge (containing that font) had been loaded in the printer.

## ESCAPE SEQUENCE

An escape sequence is a string of several characters that is used to select most of the printer's features. Each escape sequence begins with the control code `^c`, the escape character. When these escape sequences are sent to the printer, the printer interprets the sequences as commands to select specific features. For example, if you wish to set the left margin to column 9, you would send the `^c&a9L` sequence to the printer before you begin printing your text. The method of sending the escape sequence depends on the computer, computer language, or software package you are using. Most software packages have escape sequences already embedded in the software, so you may never have to get directly involved with escape sequences. If you wish to send escape

sequences on your own, however, consult your terminal/computer reference manual for information on sending the escape character. With most Hewlett-Packard terminals/computers, to send escape sequences you enter the DISPLAY FUNCTIONS mode, type in the escape sequence (press the ESC key and then the rest of the sequence), and then exit the DISPLAY FUNCTIONS mode. When the data is sent to the printer, the printer will interpret the escape sequences as commands and perform them as you have specified.

If you are using BASIC programming language, the escape character is represented by CHR\$(27).

## FONT

A font is a set of characters of a specific orientation (portrait/landscape), symbol set, spacing, pitch, point size, style, stroke weight, and typeface. Two character fonts are stored in memory within the LaserJet printer and come standard with the printer--these are called the printer's resident fonts. (LaserJet<sup>+</sup> and LaserJet 500<sup>+</sup> have more resident fonts than the LaserJet printer.) Other character fonts are accessible when an optional font cartridge is installed in the printer. (LaserJet<sup>+</sup> and LaserJet 500<sup>+</sup> printers can also use fonts which are stored on disc and downloaded to the printer.) Character fonts are accessed by specifying the characteristics (attributes) of the particular font you wish to print with (such as orientation, pitch, point size, etc.).

## LANDSCAPE ORIENTATION

Landscape orientation refers to printing from left to right across the length of the page (as opposed to portrait--printing from left to right across the width of the page). The term "landscape" is derived from pictures of landscape, which are usually in the horizontal format. Switching orientation is accomplished by sending the  $\text{Esc}\&\#0$  ( $\# = 0$  or  $1$ ) escape sequence to the printer.

## MACROS

A macro is a command that combines other commands (and/or data) for simplification purposes. For example, you could define a macro that sets the pagelength to 66 lines per inch, the left margin to column 10, and the right margin to column 70. Once that macro is defined, calling or executing the macro performs the operation of setting the pagelength and margins. Macros may be created to perform functions such as automatically overlaying a letterhead on each printed page and may range in size from simple combinations of 2 or 3 escape sequences to macros which combine several pages of commands into one command.

## PITCH

Pitch refers to the number of characters that can be placed in a horizontal inch of text. Each fixed-pitch (non-proportional) character font has a specific pitch (expressed in characters per inch [cpi]) which is specified on the font cartridge. For example, the Line Printer font is designed as a 16.66 pitch font (that is, 16.66 characters printed per linear inch). **NOTE: The stated font pitch can be overridden by changing the pitch via the horizontal motion index (HMI).**

## POINT

A point is a unit of measurement that equals  $1/72$  inch. The height of character fonts is specified in points. For example, the Line Printer character font in font cartridge 92286A is an 8.5 point font. In other words, the font is approximately  $.118$  inches high ( $8.5 \times 1/72$  inches).

## PORTRAIT ORIENTATION

Portrait orientation refers to printing from left to right across the width of the page (letter-style). This is the opposite of landscape orientation, which is printing from left to right across the length of the page. Switching orientation is accomplished by sending the `Esc&I#O` (# = 0 or 1) escape sequence to the printer. The term "portrait" is derived from portraits of people, which are usually in the vertical format.

## PROPORTIONAL SPACING

Proportional spacing is character spacing where the horizontal space occupied by each character is based on the character's width (for example, a "W" occupies more space than an "I"). This manual is printed in a proportionally-spaced font. Normal typewriters use fixed spacing.

## ROMAN-8/ROMAN EXTENSION

Hewlett-Packard's standard symbol set is Roman-8. Roman-8 is a combination of the USASCII symbol set plus the Roman Extension symbol set (Roman Extension is a full set of European and special symbols). Roman-8 is an eight-bit symbol set. See Appendix B.

## RULES

A rule is a solid-black rectangle, varying in size from a few dots by a few dots to a black rectangle which encompasses almost the entire page. Rules are useful for creating borders around pages and for enhancing letterheads and forms. The size of rules is specified using escape sequences to set the height and width of the rectangle.



---

# INDEX

---

## A

|  |         |
|--|---------|
| Addressable Areas . . . . .                                | 5-3     |
| Advanced Font Features (LaserJet+/LaserJet 500+) . . . . . | 3-4     |
| Advanced Graphics . . . . .                                | 3-33    |
| Advanced Printer Features . . . . .                        | 3-1     |
| ASCII Tables . . . . .                                     | B-1     |
| Assigning Font ID # to Font Cartridge Font . . . . .       | 3-20    |
| Auto Macro Overlay . . . . .                               | 3-29    |
| Auto-Continue Mode, Selecting . . . . .                    | C-7,C-8 |
| Auto-Select Mode. Configuring Power-Up State . . . . .     | 4-11    |
| Auto-Select Mode. Definition . . . . .                     | GL-1    |
| Auto-Select Mode . . . . .                                 | 4-2,C-8 |
| Automatic Underlining . . . . .                            | 2-44    |
| Automatic Underlining, Hints . . . . .                     | 5-9     |

## B

|                                      |         |
|--------------------------------------|---------|
| Backspace ( <sup>␣</sup> ) . . . . . | 2-3,2-4 |
| Baud Rate, Changing . . . . .        | C-1,C-4 |
| Baud rate, Definition . . . . .      | GL-1    |
| Bold . . . . .                       | 2-31    |

## C

|  |         |
|--|---------|
| Cable Pin Assignments . . . . .                        | D-1     |
| Cabling, Parallel Interface . . . . .                  | D-6     |
| Cabling, Serial Interface . . . . .                    | D-3     |
| Carriage Return ( <sup>␣</sup> ) . . . . .             | 2-3,2-4 |
| Centronics Parallel Interface, Configuration . . . . . | D-1     |
| Changing Baud Rate . . . . .                           | C-4     |
| Character Code, Specify . . . . .                      | 3-5     |
| Character Descriptor . . . . .                         | 3-16    |
| Character Download . . . . .                           | 3-16    |
| Character Font Orientation . . . . .                   | 2-23    |
| Character Fonts (Selecting) . . . . .                  | 2-19    |
| Character Fonts, Downloading—General Method . . . . .  | 3-26    |
| Character Height (Point Size) Selection . . . . .      | 2-29    |

|  |           |
|--|-----------|
| Character Overstrike . . . . .                         | 2-44      |
| Character Style (Italic/Upright) . . . . .             | 2-30      |
| Characteristics, Default Font . . . . .                | 2-24      |
| Clearing and Setting Side Margins . . . . .            | 2-13,2-14 |
| Combining Escape Sequences . . . . .                   | 1-10      |
| Configuration, Interface . . . . .                     | D-1       |
| Configuration, Parallel Interface . . . . .            | D-5       |
| Control Codes . . . . .                                | 1-6,2-3   |
| Control Codes, Backspace . . . . .                     | 2-3       |
| Control Codes, Carriage Return . . . . .               | 2-3       |
| Control Codes, Escape . . . . .                        | 2-3       |
| Control Codes, Form Feed . . . . .                     | 2-3       |
| Control Codes, Line Feed . . . . .                     | 2-3       |
| Control Codes, Shift Out . . . . .                     | 2-3       |
| Control Codes, Shift In . . . . .                      | 2-3       |
| Copy/Assign Fonts—Font and Character Control . . . . . | 3-6       |
| Create Font (Font Descriptor) . . . . .                | 3-9       |
| Current Environment Variables . . . . .                | 3-29      |
| Cursor Control—LaserJet+/LaserJet 500+ . . . . .       | 3-2       |
| Cursor Position, Push/Pop . . . . .                    | 3-32      |
| Cursor Positioning, Vertical (using lines) . . . . .   | 2-16      |
| Cursor Positioning . . . . .                           | 2-15      |
| Cursor Spacing, Horizontal . . . . .                   | 2-12      |
| Cursor, Definition . . . . .                           | GL-1      |

## D

|  |      |
|--|------|
| Decipoint, Definition . . . . .                            | GL-2 |
| Decipoints (Using to Position Horizontally) . . . . .      | 2-17 |
| Decipoints (Using to Position Vertically) . . . . .        | 2-18 |
| Default Font Characteristics . . . . .                     | 2-24 |
| Default Fonts . . . . .                                    | 2-24 |
| Default Margins . . . . .                                  | 5-4  |
| Default Page Format . . . . .                              | 2-6  |
| Default Values . . . . .                                   | 2-48 |
| Default, Primary Font . . . . .                            | 3-8  |
| Default, Secondary Font . . . . .                          | 3-9  |
| Delete Character Code—Font and Character Control . . . . . | 3-6  |
| Deleting Fonts—Font and Character Control . . . . .        | 3-6  |
| Designate Downloaded Font as Primary . . . . .             | 3-7  |
| Designate Downloaded Font as Secondary . . . . .           | 3-8  |
| Display Functions and Transparent Print Data . . . . .     | 2-42 |
| Dot Spacing, Horizontal Moves . . . . .                    | 3-3  |



|  |      |
|--|------|
| Dot Spacing, Vertical Moves . . . . .                | 3-3  |
| Download Character . . . . .                         | 3-16 |
| Downloaded Font, Designate as Primary . . . . .      | 3-7  |
| Downloaded Font, Designate as Secondary . . . . .    | 3-8  |
| Downloading Character Fonts—General Method . . . . . | 3-26 |
| Downloading Hewlett-Packard Fonts . . . . .          | 3-21 |
| Downloading, Definition . . . . .                    | GL-2 |
| Dual Cassette Selection . . . . .                    | 4-2  |

## E

|   |          |
|---|----------|
| End Raster Graphics . . . . .                             | 2-39     |
| End-Of-Line Wrap . . . . .                                | 2-46     |
| Escape (E <sub>c</sub> ) . . . . .                        | 2-3,2-4  |
| Escape Sequences . . . . .                                | 1-6      |
| Escape Sequence Summary . . . . .                         | A-1      |
| Escape Sequence, Definition . . . . .                     | GL-2     |
| Escape Sequences (Combining). . . . .                     | 1-10     |
| Escape Sequences for Advanced Graphics . . . . .          | 3-34     |
| Escape Sequences, Font Management . . . . .               | 3-5      |
| Escape Sequences, Macro . . . . .                         | 3-27     |
| Example—Assigning Font ID to Font Cartridge Font. . . . . | 3-20     |
| Example—Downloading HP Fonts. . . . .                     | 3-22     |
| Example—Gray Scale . . . . .                              | 3-39     |
| Example—Job Offset . . . . .                              | 4-6      |
| Example—Macros . . . . .                                  | 3-31     |
| Example—Paper Input Control/Job Offset . . . . .          | 4-10     |
| Example—Pattern . . . . .                                 | 3-39     |
| Example—Push/Pop. . . . .                                 | 3-33     |
| Example—Raster Graphics. . . . .                          | 2-40     |
| Example—Rule . . . . .                                    | 3-38     |
| Example—Selecting a Character font. . . . .               | 2-33     |
| Example—Sheet Feeder Control . . . . .                    | 4-9,4-10 |

## F

|   |          |
|---|----------|
| Features, LaserJet 500+ . . . . .           | 1-5      |
| Features, LaserJet Printer Family . . . . . | 2-1      |
| Features, LaserJet vs. LaserJet+ . . . . .  | 1-3      |
| Fixed Spacing vs Proportional . . . . .     | 2-27     |
| Font Descriptor, (Create Font). . . . .     | 3-9,3-11 |
| Font Header (Font Descriptor) . . . . .     | 3-9      |
| Font ID . . . . .                           | 3-5      |

|   |         |
|---|---------|
| Font Management Escape Sequences. . . . . | 3-5     |
| Font Selection, Hints. . . . .            | 5-7     |
| Font and Character Control . . . . .      | 3-6     |
| Font, Definition . . . . .                | GL-3    |
| Fonts (LaserJet+/LaserJet 500+). . . . .  | 3-4     |
| Fonts, Character (Selecting). . . . .     | 2-19    |
| Fonts, Default . . . . .                  | 2-24    |
| Fonts, Downloading . . . . .              | 3-21    |
| Fonts, Resident. . . . .                  | 2-24    |
| Form Feed (Fr). . . . .                   | 2-3,2-4 |
| Formatting, Hints . . . . .               | 5-3     |
| Formatting, Page . . . . .                | 2-14    |
| Functions, Display . . . . .              | 2-42    |

**G**

|                                       |      |
|---------------------------------------|------|
| General Information . . . . .         | 1-1  |
| Glossary . . . . .                    | GL-1 |
| Graphics, Raster . . . . .            | 2-35 |
| Graphics Resolution (Raster). . . . . | 2-36 |
| Graphics, Advanced . . . . .          | 3-33 |
| Graphics, Raster (End). . . . .       | 2-39 |
| Graphics, Raster (Start) . . . . .    | 2-38 |
| Graphics, Raster (Transfer). . . . .  | 2-38 |
| Gray Scale Example . . . . .          | 3-39 |
| Gray Scale Patterns. . . . .          | 3-36 |

**H**

|   |      |
|---|------|
| Half Line Feed. . . . .                                 | 2-45 |
| Hints—Auto Underlining. . . . .                         | 5-9  |
| Hints—Font Selection. . . . .                           | 5-7  |
| Hints—LaserJet+/LaserJet 500+ Throughput . . . . .      | 5-12 |
| Hints—LaserJet+/LaserJet 500+ Font Management . . . . . | 5-13 |
| Hints—Multiple Copies . . . . .                         | 5-12 |
| Hints—Page Formatting . . . . .                         | 5-3  |
| Hints—Page Printing . . . . .                           | 5-2  |
| Hints—Programming . . . . .                             | 5-1  |
| Hints—Raster Graphics. . . . .                          | 5-8  |
| Hints—Selecting Downloaded Fonts. . . . .               | 5-14 |
| Hints—Sending Binary Data. . . . .                      | 5-15 |
| HMI (Horizontal Motion Index). . . . .                  | 2-12 |
| Horizontal Cursor Positioning . . . . .                 | 2-15 |

|  |      |
|--|------|
| Horizontal Cursor Positioning (Using Decipoints) . . . . . | 2-17 |
| Horizontal Cursor Spacing . . . . .                        | 2-12 |
| Horizontal Cursor Spacing (Dots) . . . . .                 | 3-3  |
| Horizontal Motion Index (HMI) . . . . .                    | 2-12 |
| Horizontal Rule/Pattern Size (dots) . . . . .              | 3-34 |
| Horizontal Rule/Pattern Size (decipoints) . . . . .        | 3-34 |
| Horizontal Spacing . . . . .                               | 2-12 |
| How to Use Escape Sequences . . . . .                      | 1-6  |
| How to Use This Manual . . . . .                           | 1-5  |
| HP-Defined Patterns . . . . .                              | 3-37 |

## I

|   |      |
|---|------|
| Index . . . . .                           | I-1  |
| Interface Cable Pin Assignments . . . . . | D-1  |
| Interface Configuration . . . . .         | D-1  |
| I/O Configuration . . . . .               | D-1  |
| Italic Character Style . . . . .          | 2-30 |

## J

|                                    |         |
|------------------------------------|---------|
| Job Offset Control . . . . .       | 4-3,4-4 |
| Joining Escape Sequences . . . . . | 1-10    |

## L

|  |           |
|--|-----------|
| Landscape Orientation, Definition . . . . .              | GL-3      |
| Landscape . . . . .                                      | 2-23,2-46 |
| LaserJet 500+ Printer Features . . . . .                 | 1-5,4-1   |
| LaserJet Family Printer Features . . . . .               | 2-1       |
| LaserJet vs. LaserJet+ Printer Features . . . . .        | 1-3       |
| LaserJet+ and LaserJet 500+ Printer Features . . . . .   | 3-1       |
| LaserJet+/LaserJet 500+ Font Management, Hints . . . . . | 5-13      |
| LaserJet+/LaserJet 500+ Information . . . . .            | C-7       |
| LaserJet+/LaserJet 500+ Switch Settings . . . . .        | C-8       |
| LaserJet+/LaserJet 500+ Throughput, Hints . . . . .      | 5-12      |
| Left Margin . . . . .                                    | 2-13      |
| Limits, Addressable Areas . . . . .                      | 5-3       |
| Limits, Printable Areas . . . . .                        | 5-4       |
| Line Feed (LF) . . . . .                                 | 2-3,2-4   |
| Line Spacing, Vertical . . . . .                         | 2-11      |
| Line Termination . . . . .                               | 2-45      |
| Lines Per Inch (Setting) . . . . .                       | 2-11      |

## M

|   |      |
|---|------|
| Macro Control . . . . .                       | 3-27 |
| Macro Escape Sequences . . . . .              | 3-27 |
| Macro Example . . . . .                       | 3-31 |
| Macro ID . . . . .                            | 3-27 |
| Macro Overlay . . . . .                       | 3-29 |
| Macro, Definition . . . . .                   | GL-4 |
| Macro . . . . .                               | 3-27 |
| Margin, Side (Setting and Clearing) . . . . . | 2-13 |
| Margins, Default . . . . .                    | 5-4  |
| Memory Utilization . . . . .                  | 3-2  |
| Multiple Copies, Hints . . . . .              | 5-12 |

## N

|                                      |      |
|--------------------------------------|------|
| Number Of Copies Selection . . . . . | 2-47 |
|--------------------------------------|------|

## O

|  |           |
|--|-----------|
| Offset Stacking . . . . .                  | 4-4       |
| Orientation (Portrait/Landscape) . . . . . | 2-23,2-46 |
| Overlay Default Variables . . . . .        | 3-30      |
| Overlay Environment Variables . . . . .    | 3-30      |
| Overlay, Auto Macro . . . . .              | 3-29      |

## P

|   |          |
|---|----------|
| Page Format, Default . . . . .                  | 2-6      |
| Page Formatting, Hints . . . . .                | 5-3      |
| Page Formatting . . . . .                       | 2-14     |
| Page Length Selection . . . . .                 | 2-4      |
| Page Length Selection (LaserJet 500+) . . . . . | 4-8      |
| Page Length . . . . .                           | 2-5,2-7  |
| Page Printing, Hints . . . . .                  | 5-2      |
| Paper Input Cassette . . . . .                  | 2-48     |
| Paper Input Control (LaserJet 500+) . . . . .   | 4-7      |
| Paper Input Control . . . . .                   | 2-47,4-3 |
| Paper Stacking Lever . . . . .                  | 4-2      |
| Paper Tray Configuration, Recommended . . . . . | 4-3      |
| Parallel Interface Cabling . . . . .            | D-6      |
| Parallel Interface, Configuration . . . . .     | D-1,D-5  |
| Pattern Example . . . . .                       | 3-39     |

|  |             |
|--|-------------|
| Pattern ID. . . . .                                  | 3-35        |
| Perforation Skip Mode . . . . .                      | 2-43        |
| Perforation Skip Region. . . . .                     | 2-5         |
| Permanent Fonts—Font and Character Control . . . . . | 3-6         |
| Pin Assignments . . . . .                            | D-1,D-3,D-7 |
| Pitch, Definition. . . . .                           | GL-4        |
| Point Size (Character Height) Selection . . . . .    | 2-29        |
| Point, Definition. . . . .                           | GL-4        |
| Portrait Orientation, Definition . . . . .           | GL-5        |
| Portrait/Landscape Orientation . . . . .             | 2-46        |
| Portrait . . . . .                                   | 2-23,2-46   |
| Position, Push/Pop . . . . .                         | 3-32        |
| Positioning Curser using lines, Vertical . . . . .   | 2-16        |
| Positioning Curser . . . . .                         | 2-15        |
| Power-On State, Auto-Select Mode. . . . .            | 4-11        |
| Primary Font Default . . . . .                       | 3-8         |
| Primary and Secondary Character Fonts . . . . .      | 2-34        |
| Print Data, Transparent . . . . .                    | 2-42        |
| Print Orientation . . . . .                          | 2-46        |
| Print Pitch Selection . . . . .                      | 2-28        |
| Print Rule/Pattern . . . . .                         | 3-38        |
| Printable Areas, Limits. . . . .                     | 5-4         |
| Printer Features, LaserJet 500+ . . . . .            | 4-1         |
| Program Compatibility. . . . .                       | 1-2         |
| Programming Hints. . . . .                           | 5-1         |
| Proportional Spacing, Definition . . . . .           | GL-5        |
| Proportional vs Fixed Spacing. . . . .               | 2-27        |
| Push/Pop Example . . . . .                           | 3-33        |
| Push/Pop Position. . . . .                           | 3-32        |

## R

|                                       |      |
|---------------------------------------|------|
| Raster Graphics . . . . .             | 2-35 |
| Raster Graphics ( End) . . . . .      | 2-39 |
| Raster Graphics (\$Start). . . . .    | 2-38 |
| Raster Graphics (^Transfer) . . . . . | 2-38 |
| Raster Graphics Resolution. . . . .   | 2-36 |
| Raster Graphics, Hints. . . . .       | 5-8  |
| Reset . . . . .                       | 2-48 |
| Resident Fonts. . . . .               | 2-24 |
| Resolution, Raster Graphics . . . . . | 2-36 |
| Right Margin. . . . .                 | 2-13 |
| Roman-8/Roman Extension . . . . .     | GL-5 |

|  |      |
|--|------|
| RS-232C/RS-422 Interfaces, Switching Between . . . . . | C-1  |
| Rule Example . . . . .                                 | 3-38 |
| Rule/Pattern Size, Horizontal (dots) . . . . .         | 3-34 |
| Rule/Pattern Size, Horizontal (decipoints). . . . .    | 3-34 |
| Rule/Pattern Size, Vertical (dots) . . . . .           | 3-35 |
| Rule/Pattern Size, Vertical (decipoints) . . . . .     | 3-35 |
| Rule/Pattern, Print . . . . .                          | 3-38 |
| Rules, Definition . . . . .                            | GL-5 |

## S

|   |              |
|---|--------------|
| Secondary Font Default. . . . .                     | 3-9          |
| Secondary and Primary Character Fonts . . . . .     | 2-34         |
| Select Number Of Copies . . . . .                   | 2-47         |
| Select Page Length . . . . .                        | 4-3          |
| Select Print Pitch . . . . .                        | 2-28         |
| Selecting Character Fonts. . . . .                  | 2-19         |
| Selecting Character Height . . . . .                | 2-29         |
| Selecting Downloaded Fonts, Hints. . . . .          | 5-14         |
| Selecting Page Length . . . . .                     | 2-4,2-7      |
| Selecting Page Length (LaserJet 500+) . . . . .     | 4-8          |
| Selecting Paper Cassettes (LaserJet 500+) . . . . . | 4-7          |
| Selecting Point Size . . . . .                      | 2-29         |
| Selecting Text Length . . . . .                     | 2-4,2-10     |
| Selecting Top Margin . . . . .                      | 2-4          |
| Selecting Typeface . . . . .                        | 2-32         |
| Self-test . . . . .                                 | 2-51         |
| Sending Binary Data, Hints. . . . .                 | 5-15         |
| Serial Interface Cabling . . . . .                  | D-3          |
| Serial Interface, Configuration. . . . .            | D-1          |
| Setting Lines Per Inch . . . . .                    | 2-11         |
| Setting The Top Margin. . . . .                     | 2-9          |
| Setting Vertical Motion Index . . . . .             | 2-12         |
| Setting and Clearing Side Margins. . . . .          | 2-13         |
| Sheet Feeder Control. . . . .                       | 4-2          |
| Shift In ( <sup>Si</sup> ) . . . . .                | 2-3,2-4,2-34 |
| Shift Out ( <sup>So</sup> ). . . . .                | 2-3,2-4,2-34 |
| Skip Mode, Perforation . . . . .                    | 2-43         |
| Spacing, Cursor (Horizontal) . . . . .              | 2-12         |
| Specialized Printer Control . . . . .               | 2-48         |
| Specify Character Code . . . . .                    | 3-5          |
| Specify Font ID . . . . .                           | 3-5          |
| Start Raster Graphics. . . . .                      | 2-38         |

|   |      |
|---|------|
| Stroke Weight . . . . .   | 2-31 |
| Style, Character (Italic/Upright). . . . .                        | 2-30 |
| Switch Settings (LaserJet 500+) . . . . .                         | C-8  |
| Switching Between Primary and Secondary Character Fonts . . . . . | 2-34 |
| Switching Character Fonts . . . . .                               | 2-34 |
| Switching RS-232C/RS-422 Interfaces and Baud Rate. . . . .        | C-1  |
| Symbol Set Selection . . . . .                                    | 2-25 |

## T

|   |           |
|---|-----------|
| Temporary Fonts--Font and Character Control . . . . . | 3-6       |
| Text Length Selection . . . . .                       | 2-4,2-10  |
| Text Length. . . . .                                  | 2-5,2-10  |
| Top Margin Selection . . . . .                        | 2-4       |
| Top Margin Setting . . . . .                          | 2-9       |
| Top Margin. . . . .                                   | 2-5,2-9   |
| Transfer Raster Graphics . . . . .                    | 2-38      |
| Transparent Print Data . . . . .                      | 2-42,2-43 |
| Typeface Selection . . . . .                          | 2-32      |
| Typeface . . . . .                                    | 2-32      |

## U

|                                   |      |
|-----------------------------------|------|
| Underlining (Automatic) . . . . . | 2-44 |
| Underlining, Hints. . . . .       | 5-9  |
| Unprintable Region. . . . .       | 2-5  |
| Upright Character Style. . . . .  | 2-30 |
| Useful Information. . . . .       | 1-9  |
| Using This Manual . . . . .       | 1-5  |

## V

|  |           |
|--|-----------|
| Vertical Cursor Positioning (using lines). . . . . | 2-16      |
| Vertical Cursor Positioning (Dots) . . . . .       | 3-3       |
| Vertical Line Spacing. . . . .                     | 2-11      |
| Vertical Motion Index (VMI). . . . .               | 2-11,2-12 |
| Vertical Positioning (Using Decipoints) . . . . .  | 2-18      |
| Vertical Rule/Pattern Size (dots) . . . . .        | 3-35      |
| Vertical Rule/Pattern Size (decipoints). . . . .   | 3-35      |
| VMI (Vertical Motion Index). . . . .               | 2-11,2-12 |

|                                |      |
|--------------------------------|------|
| Weight, Stroke . . . . .       | 2-31 |
| Wrapping End Of Line . . . . . | 2-46 |

## CONTROL CODES AND ESCAPE SEQUENCES

|   |           |
|---|-----------|
| B <sub>S</sub> (Backspace) . . . . .  | 2-4       |
| C <sub>R</sub> (Carriage Return) . . . . .                                    | 2-4       |
| F <sub>F</sub> (Form Feed) . . . . .  | 2-4       |
| L <sub>F</sub> (Line Feed) . . . . .  | 2-4       |
| S <sub>I</sub> (Shift In) . . . . .   | 2-4       |
| S <sub>O</sub> (Shift Out) . . . . .  | 2-4       |
| E <sub>C</sub> = Half Line Feed . . . . .                                     | 2-45      |
| E <sub>C</sub> &10O--Portrait Orientation . . . . .                           | 2-23,2-46 |
| E <sub>C</sub> &a#C--Horizontal Cursor Positioning (columns) . . . . .        | 2-15      |
| E <sub>C</sub> &a#H--Horizontal Cursor Positioning (decipoints) . . . . .     | 2-17      |
| E <sub>C</sub> &a#L--Left Margin . . . . .                                    | 2-13      |
| E <sub>C</sub> &a#M--Right Margin . . . . .                                   | 2-13      |
| E <sub>C</sub> &a#R--Vertical Cursor Positioning (lines) . . . . .            | 2-16      |
| E <sub>C</sub> &a#V--Vertical Cursor Positioning (decipoints) . . . . .       | 2-18      |
| E <sub>C</sub> &d@--Disable Auto-Underlining . . . . .                        | 2-44      |
| E <sub>C</sub> &dD--Enable Auto-Underlining . . . . .                         | 2-44      |
| E <sub>C</sub> &f#S--Push/Pop Position . . . . .                              | 3-32      |
| E <sub>C</sub> &f#X--Macro Control . . . . .                                  | 3-27      |
| E <sub>C</sub> &f#Y--Macro ID . . . . .                                       | 3-27      |
| E <sub>C</sub> &k#G--Line Termination . . . . .                               | 2-45      |
| E <sub>C</sub> &k#H--Horizontal Motion Index (HMI) . . . . .                  | 2-12      |
| E <sub>C</sub> &k#S--Font Pitch (primary and secondary) . . . . .             | 2-29      |
| E <sub>C</sub> &l#C--Vertical Spacing (VMI) . . . . .                         | 2-12      |
| E <sub>C</sub> &l#D--Vertical Spacing (LPI) . . . . .                         | 2-11      |
| E <sub>C</sub> &l#E--Top Margin . . . . .                                     | 2-9       |
| E <sub>C</sub> &l#F--Text Length . . . . .                                    | 2-11      |
| E <sub>C</sub> &l#H--Paper Input Control . . . . .                            | 2-47      |
| E <sub>C</sub> &l#P--Page Length . . . . .                                    | 2-7       |
| E <sub>C</sub> &l#X--Select Number of Copies . . . . .                        | 2-47      |
| E <sub>C</sub> &10L--Disable Perforation Skip Mode . . . . .                  | 2-43      |
| E <sub>C</sub> &10T--Default Stacking Position . . . . .                      | 4-5       |
| E <sub>C</sub> &11L--Enable Perforation Skip Mode . . . . .                   | 2-43      |
| E <sub>C</sub> &11O--Landscape Orientation . . . . .                          | 2-23,2-46 |
| E <sub>C</sub> &11T--Toggle Stacking Position . . . . .                       | 4-5       |
| E <sub>C</sub> &p#X[transparent print data]--Transparent Print Data . . . . . | 2-43      |
| E <sub>C</sub> &s0C--Enable Wrap-around Mode . . . . .                        | 2-46      |



|  |      |
|--|------|
| <code>&amp;cs1C</code> --Disable Wrap-around Mode . . . . .                    | 2-46 |
| <code>Ec(#@</code> --Primary Font Default . . . . .                            | 3-8  |
| <code>Ec(#X</code> --Designate Downloaded Font as Primary . . . . .            | 3-7  |
| <code>Ec(0A</code> --Math Symbol Set (primary) . . . . .                       | 2-26 |
| <code>Ec(0B</code> --Line Draw Symbol Set (primary) . . . . .                  | 2-26 |
| <code>Ec(0U</code> --USASCII Symbol Set (primary) . . . . .                    | 2-26 |
| <code>Ec(8K</code> --Kana-8 Symbol Set (primary) . . . . .                     | 2-26 |
| <code>Ec(8U</code> --Roman-8 Symbol Set (primary) . . . . .                    | 2-26 |
| <code>Ec(s#B</code> --Stroke Weight (primary) . . . . .                        | 2-31 |
| <code>Ec(s#H</code> --Font Pitch (primary) . . . . .                           | 2-28 |
| <code>Ec(s#T</code> --Typeface (primary) . . . . .                             | 2-32 |
| <code>Ec(s#V</code> --Point Size (primary) . . . . .                           | 2-29 |
| <code>Ec(s#W[Descriptor and data]</code> --Download Character . . . . .        | 3-16 |
| <code>Ec(s0P</code> --Fixed Spacing (primary) . . . . .                        | 2-27 |
| <code>Ec(s0S</code> --Upright Character Style (primary) . . . . .              | 2-30 |
| <code>Ec(s1P</code> --Proportional Spacing (primary) . . . . .                 | 2-27 |
| <code>Ec(s1S</code> --Italic Character Style (primary) . . . . .               | 2-30 |
| <code>Ec)##@</code> --Secondary Font Default . . . . .                         | 3-9  |
| <code>Ec)##X</code> --Designate Downloaded Font as Secondary . . . . .         | 3-8  |
| <code>Ec)0A</code> --Math Symbol Set (secondary) . . . . .                     | 2-26 |
| <code>Ec)0B</code> --Line Draw Symbol Set (secondary) . . . . .                | 2-26 |
| <code>Ec)0U</code> --USASCII Symbol Set (secondary) . . . . .                  | 2-26 |
| <code>Ec)8K</code> --Kana-8 Symbol Set (secondary) . . . . .                   | 2-26 |
| <code>Ec)8U</code> --Roman-8 Symbol Set (secondary) . . . . .                  | 2-26 |
| <code>Ec)s#B</code> --Stroke Weight (secondary) . . . . .                      | 2-31 |
| <code>Ec)s#H</code> --Font Pitch (secondary) . . . . .                         | 2-28 |
| <code>Ec)s#T</code> --Typeface (secondary) . . . . .                           | 2-32 |
| <code>Ec)s#V</code> --Point Size (secondary) . . . . .                         | 2-29 |
| <code>Ec)s#W[font descriptor]</code> --Create Font (Font Descriptor) . . . . . | 3-9  |
| <code>Ec)s0P</code> --Fixed Spacing (secondary) . . . . .                      | 2-27 |
| <code>Ec)s0S</code> --Upright Character Style (secondary) . . . . .            | 2-30 |
| <code>Ec)s1P</code> --Proportional Spacing (secondary) . . . . .               | 2-27 |
| <code>Ec)s1S</code> --Italic Character Style (secondary) . . . . .             | 2-30 |
| <code>Ec*c#W[raster data]</code> --Transfer Raster Graphics . . . . .          | 2-38 |
| <code>Ec*c#A</code> --Horizontal Rule/Pattern Size . . . . .                   | 3-34 |
| <code>Ec*c#B</code> --Vertical Rule/Pattern Size (dots) . . . . .              | 3-35 |
| <code>Ec*c#D</code> --Specify Font ID . . . . .                                | 3-5  |
| <code>Ec*c#E</code> --Specify Character Code . . . . .                         | 3-5  |
| <code>Ec*c#F</code> --Font and Character Control . . . . .                     | 3-6  |
| <code>Ec*c#G</code> --Pattern ID . . . . .                                     | 3-35 |
| <code>Ec*c#H</code> --Horizontal Rule/Pattern Size (decipoints) . . . . .      | 3-34 |
| <code>Ec*c#P</code> --Print Rule/Pattern . . . . .                             | 3-38 |
| <code>Ec*c#V</code> --Vertical Rule/Pattern Size (decipoints) . . . . .        | 3-35 |

|  |      |
|--|------|
| <b>E<sub>c</sub>*p#X</b> –Horizontal Cursor Moves (dots) . . . . . | 3-3  |
| <b>E<sub>c</sub>*p#Y</b> –Vertical Cursor Moves (dots) . . . . .   | 3-3  |
| <b>E<sub>c</sub>*r#A</b> –Start Raster Graphics . . . . .          | 2-38 |
| <b>E<sub>c</sub>*r#B</b> –End Raster Graphics . . . . .            | 2-39 |
| <b>E<sub>c</sub>*t#R</b> –Raster Graphics Resolution. . . . .      | 2-36 |
| <b>E<sub>c</sub>9</b> –Clear Side Margins . . . . .                | 2-14 |
| <b>E<sub>c</sub>Y</b> –Enable Display Functions Mode . . . . .     | 2-42 |
| <b>E<sub>c</sub>Z</b> –Disable Display Functions Mode . . . . .    | 2-42 |
| <b>E<sub>c</sub></b> –(Escape) . . . . .                           | 2-4  |

# - User Comment Sheet - LaserJet Printer Family Technical Reference Manual

We welcome your evaluation of this manual. Your comments and suggestions help us improve our publications. After you have had a chance to use the manual, please take a moment to answer these questions and give us any further comments. Feel free to use additional pages if needed. Once complete, drop this page in the mail. No postage is necessary if mailed in the United States.

Have you found this manual to be accurate in technical content?      Yes \_\_\_ No \_\_\_

Are the concepts explained clearly?      Yes \_\_\_ No \_\_\_

Is the format of this manual convenient in size, readability and arrangement (page layout, chapter locations, etc.)?      Yes \_\_\_ No \_\_\_

Have you found the Index and Glossary to be useful?      Yes \_\_\_ No \_\_\_

If you answered no to any of the above, or have other comments or concerns, please explain or suggest improvements below. Please be sure to note the page number or other identifying location of any specific problems or concerns.

## Comments:

---

---

---

---

## From: (optional)

---

NAME

OCCUPATION

---

COMPANY

PHONE

---

ADDRESS

---

CITY

STATE

ZIP CODE

02686-90912

January 1986

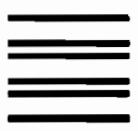

NO POSTAGE  
NECESSARY  
IF MAILED  
IN THE  
UNITED STATES

**BUSINESS REPLY MAIL**

FIRST CLASS      PERMIT NO. 141      BOISE, IDAHO 83707

POSTAGE WILL BE PAID BY ADDRESSEE

**Hewlett-Packard Company**  
**Boise Division**  
**P.O. Box 15**  
**11311 Chinden Blvd.**  
**Boise, Idaho 83707**

Attn: Technical Publications M.S. 112

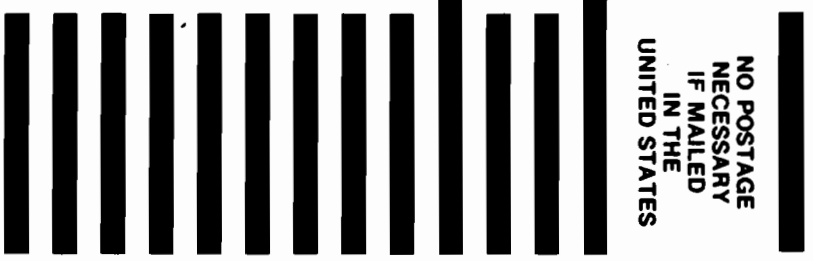



HEWLETT  
PACKARD

Part No. 02686-90912  
January 1986