

Desktop
Scanning -
It's Worth
Looking
Into

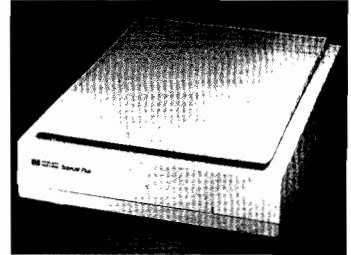

Envision New Ways
To Distinguish
Yourself

Picture This



Scanning — A Better Way

Scanners have been around for a long time, but they're no longer just for experts. Now, nearly everyone can use a scanner — legal assistants, teachers, or professional publishers — people who want to make daily tasks easier and communications more interesting.

Recognize Yourself?

Do you or your colleagues ever re-type information to edit it in a word processing package? Do you need to move data from one system to another? Have you ever wanted to store important papers electronically, but didn't want to spend the time or energy it takes to re-type them?

HP Computer Museum
www.hpmuseum.net

For research and education purposes only.

There's a lot of information floating around these days, and it's your job to get it organized quickly and make your messages distinctive. All you need is a scanner and the right software to stand out from the crowd.



Ever wish those reports you give to your boss — or the slides you show to your customers — were just a little jazzier? Have you put together manuals, product sheets, or ads with a drawing board, wax, and X-ACTO® knife? Ever fought with scissors and paste to put a graph, cartoon, or picture in a paper or presentation?

Take a Look

The samples in this booklet show you what a scanner can do and the changes it can make in the way you do everyday tasks. And high-quality, affordable, grayscale scanners like the HP ScanJet Plus scanner make those changes easy and exciting.

Imagine These Shortcuts

Crunch Time with OCR

These days everybody needs to accomplish more — in less time. That's why scanners and Optical Character Recognition (OCR) products have gotten so much press lately. OCR can save you time, money, and space!

Most documents that cross your desk are **dot-matrix** or laser-printed text, typewritten, or typeset. Scan them with OCR, and you've got a file you can work with.

It's even possible to scan complicated or bound pages, like **magazine articles** or **books**, and put them in a database to use when you're putting together your big report.

When you're facing a big **contract**, use OCR to clinch the deal faster. Don't wait while the revision is re-typed — scan pages automatically with a document feeder and OCR, bring them into your favorite word processor, and you're ready to add those key points.

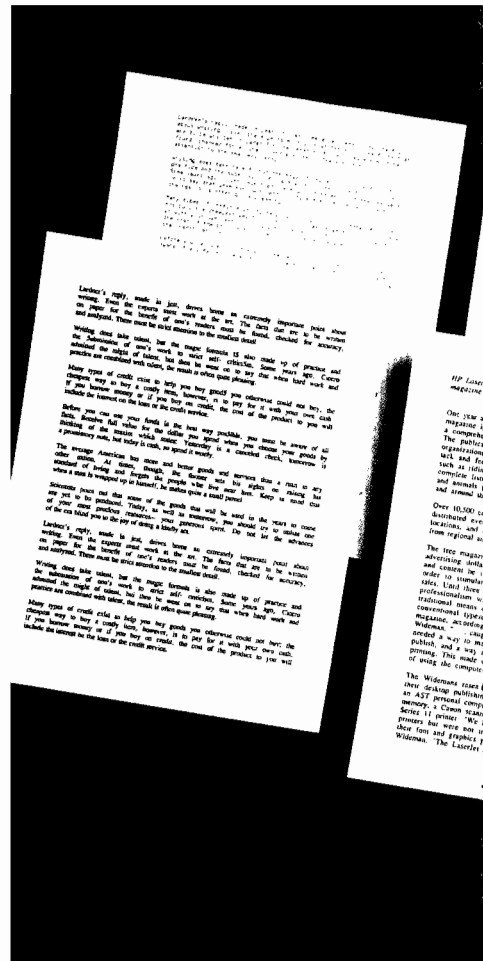

Make your mark by teaming the HP ScanJet Plus scanner, the automatic document feeder, and a powerful OCR package. Turn an existing document into a file you can save, edit, print, or send electronically — without tedious re-typing.



EXCELLENT SOLUTIONS

HP LaserJet Asia Line helps solve magazine publisher's problems

The way the magazine publishing industry has changed in the last few years has been dramatic. The industry has grown from a niche market to a major force in the publishing world. The industry has also become more competitive, with new entrants and established players alike vying for market share. The industry has also become more technologically advanced, with the use of computers and digital printing becoming increasingly common.

HP LaserJet Asia Line has helped magazine publishers solve these problems by providing a range of solutions that are tailored to their needs. These solutions include:

- **Cost-effective printing:** HP LaserJet printers are known for their low cost per page, which helps publishers reduce their printing costs.
- **High-quality output:** HP LaserJet printers produce high-quality output that is suitable for both print and digital distribution.
- **Reliability and uptime:** HP LaserJet printers are designed to be reliable and have a long lifespan, which helps publishers avoid downtime and maintain their production schedules.
- **Integration with existing systems:** HP LaserJet printers can be easily integrated with existing publishing systems, making the transition to digital printing a seamless process.

As a result of using HP LaserJet Asia Line, magazine publishers have been able to reduce their printing costs, improve the quality of their output, and increase their production efficiency. This has allowed them to compete more effectively in the market and to reach a wider audience.

BALANCE IN SOBAS-SMOLETT'S
MURPHY CINSTE

by
M. A. JONES

A Plain & Co. report submitted to the Department of English and the Graduate School of the University of Western Australia, Perth, Western Australia.

For the Executive Master of Arts

University of Western Australia, Perth, Western Australia
June 1988

4. This Agreement may be signed in one or more counterparts, which together shall constitute one and the same instrument.

In witness whereof the parties hereto have executed and delivered this Amendment as of the date first above written.

4. This Amendment shall be signed in one or more counterparts, which together shall constitute one and the same instrument.

In witness whereof the parties hereto have executed and delivered this Amendment as of the date first above written.

XXXX, a Federal Entity and Last Amendment

By: _____

RELATED AGREEMENT

In further consideration of the foregoing Amendment the undersigned hereby agree that none of XXXXX, Inc. ("XXXXX") or the Investor or the Service or XXXXX (as defined in the foregoing Amendment) have any further rights or duties in connection with the parties under that certain XXXXX Lease Servicing Agreement dated between XXXXX and XXXXX.

In addition, the undersigned agree that in connection with that certain lease dated _____ from XXXXX to XXXXX and assigned by XXXXX to the "XXXXX (as defined in the foregoing Amendment) to accept services.

4

Looking Good!

Extraordinary Word-Processing

Face it. Word-processing used to be boring. Now, graphics and sophisticated formatting are becoming standard fare in popular word processing software.

Scanning graphics and importing them into word processing software refines and enhances your daily communications. You can also save re-typing time by scanning text with OCR and importing the text files into your word processor.

Pictures are indeed worth a thousand words, particularly when they clarify **instruction sheets**.

There's nothing more ordinary than lists of products or parts — liven them up with logos and illustrations, and you've got this eye-catching **catalog listing**.

Want your **resume** to stand out? Use logos, drawings, or photos to make yours unique.

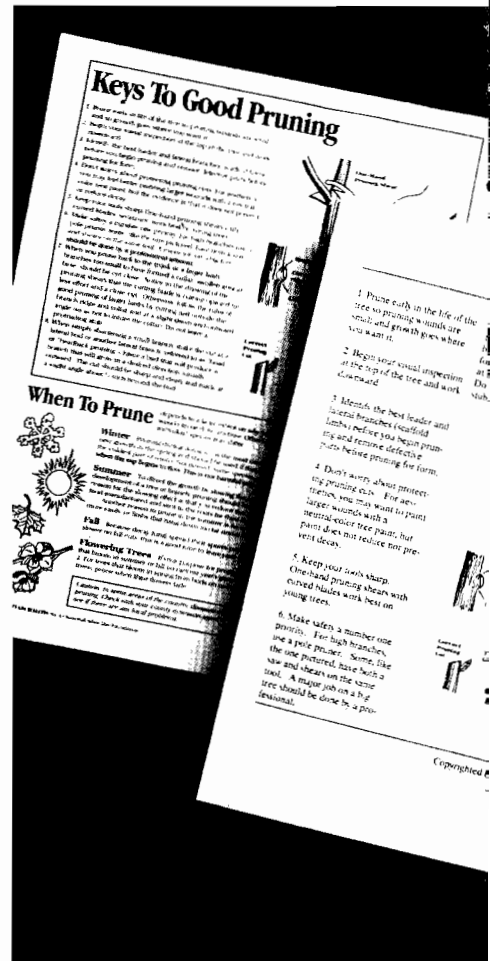

All it takes is a little imagination, the HP ScanJet Plus scanner, and the right word processing package to turn everyday documents into distinctive communications.

KEYS TO GOOD PRUNING

When you prune back to the link or a larger link, (red) should be cut close. They leave a protruding

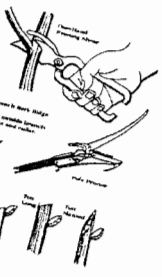

the National Arbor Day Foundation Reprinted with permission 2-90

Children's Listing, cont.



Samson and Dorothy Meet the Tiddlers, by Graham James. 1988. A delightful story about manners. Ages 3 - 5



Joseph Turn Off That Nose! by Susan Gronert. A funny story about a man who finds trouble everywhere. 1989. Ages 3-7.



How Many Elephants? by Sun R. Han. 1989. A counting book. Ages 2-5.



What's a Rainbow? by William Joseph. Poetic answers to common children's questions. 1985. Ages 4-8



Why Does that Man Walk Funny? by Matt Jones. A tale about handicaps. 1987. Ages 5-8



Alan Siddall
3307 Flax Avenue
Vero Beach, FL 32906

OBSCURE
College Assistant Football Coach

OBSCURE
M.S. Athletic Administrator, Wyoming State, Rock Center, Wyoming
June 1982

B.S. Education and Geography, Iowa University, Iowa City, Iowa, June 1975.

PROFESSIONAL EXPERIENCE
Assistant Football Coach, University of Southern Colorado, Vero Beach, CO, Detonatus Continuator, July 1987 - Present, July 1983 - July 1987.

WEST LAKE HIGH SCHOOL WILDCATS
Head Football Coach, West Lake High School, Grand Portage, CO, 1985 - J.A. High School, Record: 26 - 3 - 1, 1983 Freshballs League Champion, 1984 Co-Champion.

SAND DUNE HIGH SCHOOL
Assistant Football Coach, Wyoming State, July 1979 - June 1982, July 1975 - July 1979, J.A. High School, Grand, CO, 1978 J.A. State Champion.

Related Activities
Instituted and coordinated West Lake High Summer Football Clinic, 1982 - 1987.

Recruited for Wyoming State, 1980 - 1981.

American Association of College Football Coaches, 1987 - Present.

Colorado State High School Athletic Association, 1977 - 1986, Treasurer, 1978.

Great Impressions

Desktop Publishing and Presentation Power

Afraid of being tossed aside in a world of look-alikes? Memorable people and successful businesses need compelling communications.

Captivate your audience with **overheads** that use images to illustrate your points. You'll leave positive impressions and an unforgettable message.

Even the most typical communications need pizzazz. **Newsletters, flyers, and brochures** no longer need to be done by professional services; put them together yourself, adding images to make them effective and lively.

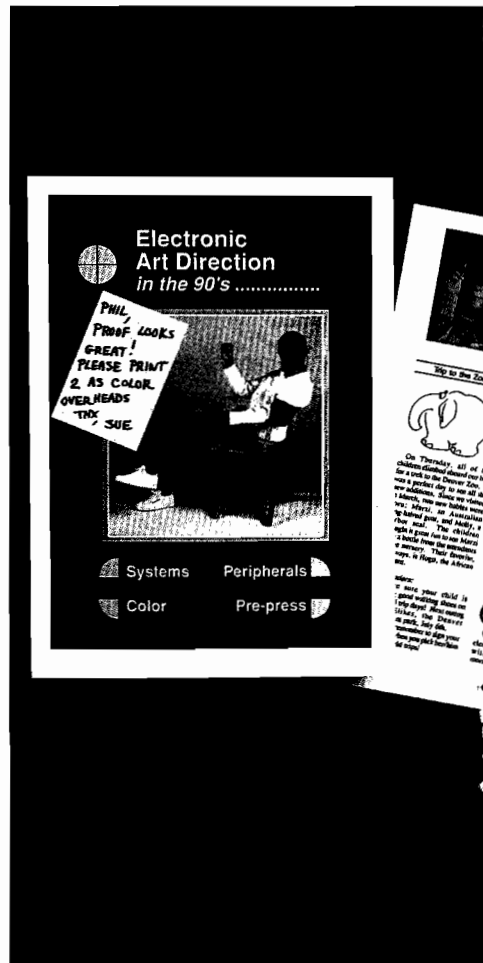

Outstanding people need outstanding communications. Tell your stories with pictures using the HP ScanJet Plus scanner and desktop publishing and presentation software.

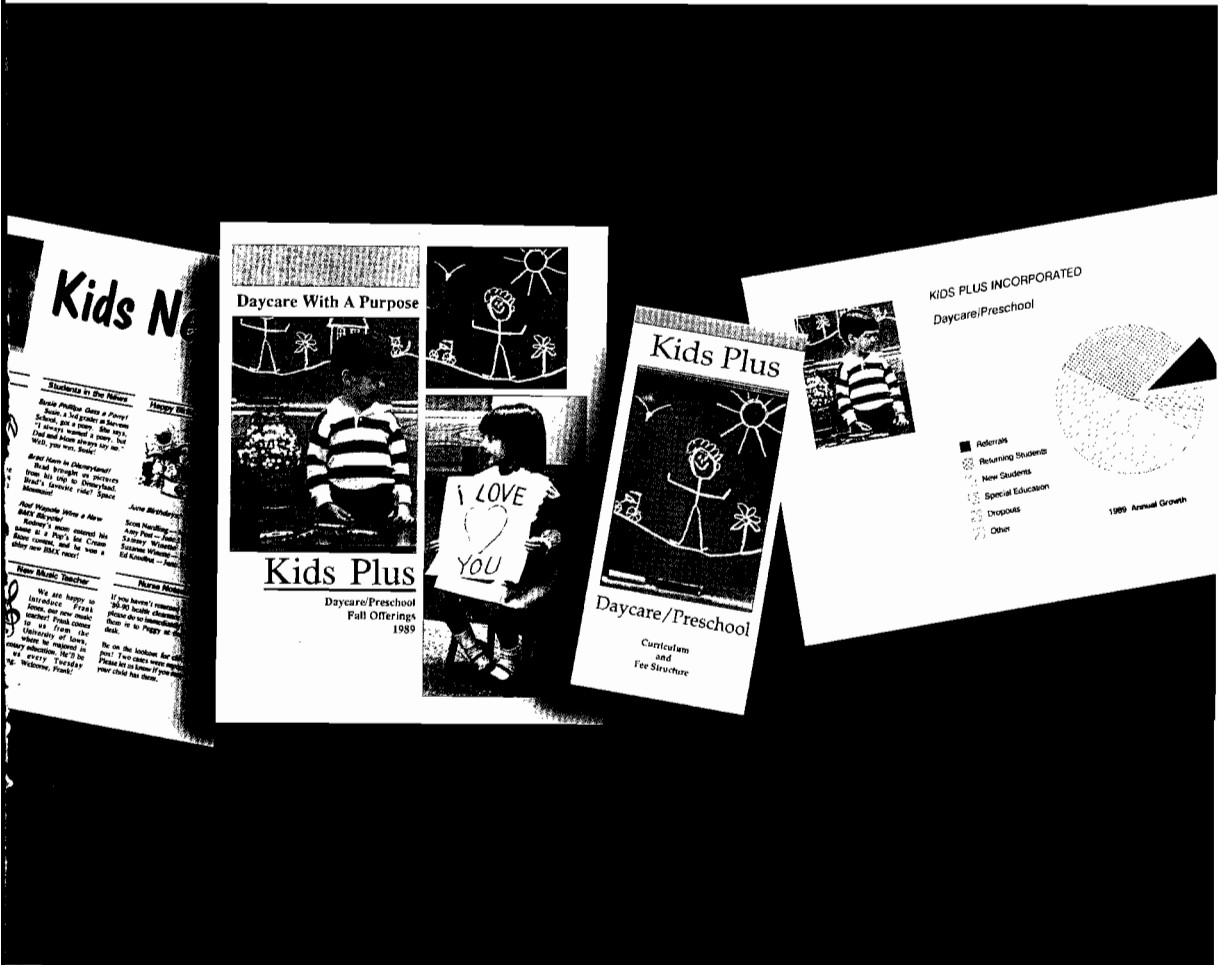

A Visible Advantage

Complexity Made Easy

To stand out, most businesses need more than impressive brochures. Technical reports, proposals, and manuals help create a company's image, too.

A few years ago, publications needing drawings or images to explain or teach were better left in the hands of a talented designer with a drawing board and X-ACTO® knife.

Now, given the right desktop publishing tools, that same designer can turn technical **articles**, **manuals**, and other complex publications into clear communications — with fewer steps and more control.

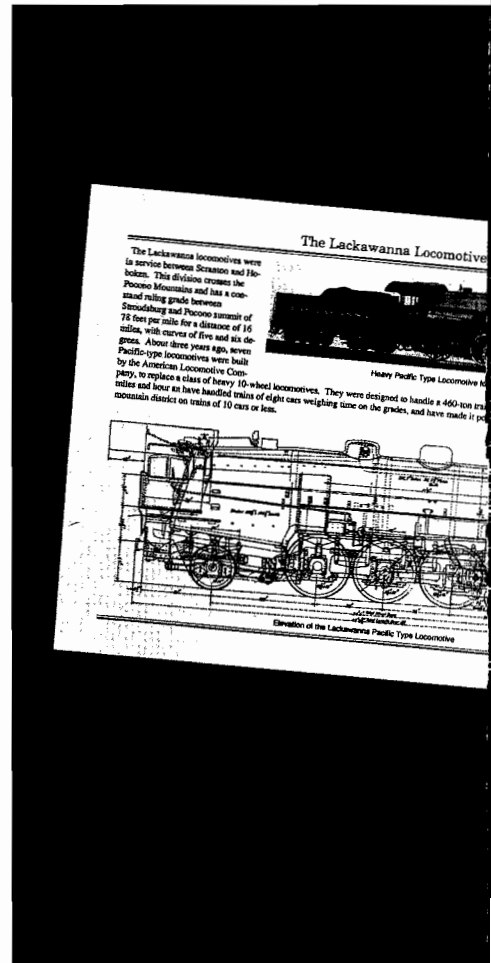

Your technical publications can be visibly better — and easier to produce — with the HP ScanJet Plus scanner and the right desktop publishing software.

Tape Drive Service Manual

1. Replaceable Parts

Tape Drive Assembly

Following is the list of replaceable parts of the Tape Drive Assembly. Refer to the diagram for the locations of the various components.

Table 1: Replaceable Parts

Assembly	Description	Part Number
1	Drive Chassis	8888-0021
2	Read/Write Head Assembly	9877-9004
3	Tape Sensor/Switch Assembly	66443B
4	Cartridge Latch/Eject Assembly (Right)	88432R
5	Cartridge Latch/Eject Assembly (Left)	88432L
6	Tape Cartridge Door Assembly	1226-5500
7	Stepper Motor Assembly	43888C
8	Drive Motor/Eject Arm Assembly	77677A

1 Replaceable Parts

Figure 1: Tape Drive Assembly

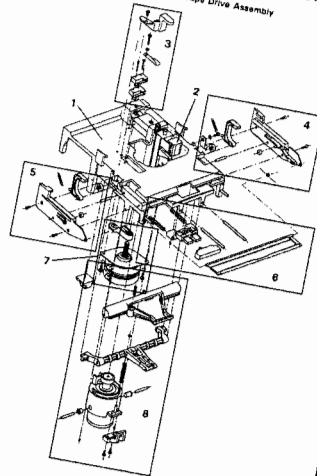

Replaceable Parts 2

Open New Vistas

Professional Publishing — A New Perspective

Okay. You'll scan images for the simpler communications, but you still leave the fancy publishing work to professional services. After all, high-resolution, quality results are achieved only by a commercial halftoning and printing process. Right?

Check again. The images on these **album**, **magazine**, and **book covers** were all scanned with the HP ScanJet Plus scanner at 256 levels of gray. Each sample was designed in a desktop publishing package, then printed on a phototypesetter as a film negative.

What does this change buy you? More time, more control, and better results! Instead of wading through phototypesetting and paste-up, the designer can see layouts immediately, experiment with different ones, and eliminate time-wasting surprises — before phototypesetting.



One glance is all it takes. Put the control back in the designer's hands with a high-quality grayscale scanner like the HP ScanJet Plus.



ORY



elegance
&
fashion

JULY 1989 \$5 USA

Ambiance and Style for the Professional Woman



- Gold ■
- SwimWear ■
- Chiffon Again? ■
- Glitz in the West ■
- Casual after 5:00 ■

TWIST



Focus on Solutions

All samples were created with the HP ScanJet Plus scanner and HP Scanning Gallery Plus or HP Desk Gallery Plus.

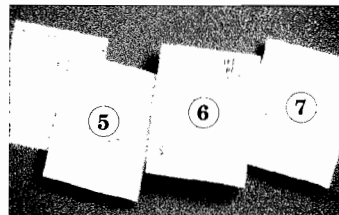
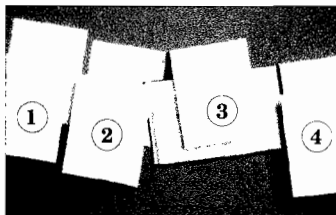

Imagine These Shortcuts

1. Dot matrix: HP Vectra PC, Calera Recognition Systems' TrueScan™ Model S. Original printed on an HP ThinkJet Printer; results printed on an HP LaserJet Series II.

2. Magazine page: Macintosh® II, Caere OmniPage™ 2.0, Apple LaserWriter NTX®.

3. Thesis cover page: Macintosh® SE, MSWord® 3.01, Apple LaserWriter Plus®.

4. Legal agreement: HP Vectra PC, Calera Recognition Systems' TrueScan™ Model S, HP LaserJet Series II.

Looking Good

5. Instruction sheet: HP Vectra PC, Calera Recognition Systems' TrueScan™ Model S, Lotus Manuscript® 2.1, HP LaserJet Series II.

6. Book catalog listing: Macintosh® SE, MSWord® 3.01, Apple LaserWriter Plus®.

7. Resume: HP Vectra PC, WordPerfect® 5.0, HP LaserJet Series II.

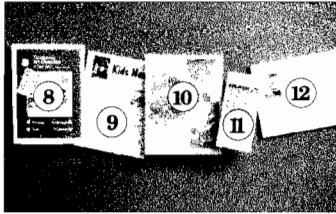

Great Impressions

8. Art director overhead: Macintosh® II, Aldus Persuasion® 1.0, Apple LaserWriter Plus®.

9. Newsletter: HP Vectra PC, HP Executive MemoMaker, Xerox Ventura Publisher® 2.0/Professional Extension, Symsoft Hotshot Graphics®, HP Type Director™ Font Management Program, Intel Visual Edge® System, HP LaserJet Series II.

10. Flyer: Macintosh® II, Aldus PageMaker® 3.01, Apple LaserWriter Plus®.

11. Brochure: Macintosh® II, Aldus PageMaker® 3.01, Apple LaserWriter Plus®.

12. Daycare overhead: HP Vectra PC, Lotus Freelance® Plus 3.0, HP LaserJet Series II.

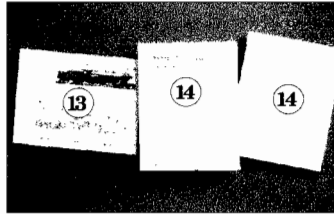

A Visible Advantage

13. Train article: Macintosh® II, Aldus PageMaker® 3.01, Apple LaserWriter Plus®.

14. Technical manual pages: HP Vectra PC, Xerox Ventura Publisher® 2.0/Professional Extension, Symsoft Hotshot Graphics®, HP Type Director® Font Management Program, HP LaserJet Series II.

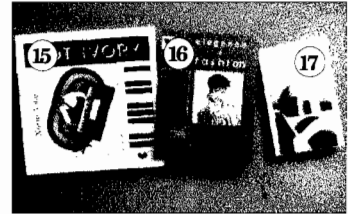

Open New Vistas

15. Album cover: Macintosh® IIX, Aldus PageMaker® 3.01, Aldus FreeHand® 2.0, Linotronic® L300. Output as film negative at 2540 dpi with a line screen of 133 lpi.

16. Magazine cover: Macintosh® IIX, Aldus PageMaker® 3.01, Linotronic® L300. Output as film negative at 2540 dpi with a line screen of 133 lpi.

17. Book cover: Macintosh® IIX, Aldus PageMaker® 3.01, Linotronic® L300. Output as film negative at 2540 dpi with a line screen of 133 lpi.



FreeHand, PageMaker, and Persuasion are registered trademarks of Aldus Corp. Freelance Plus and Manuscript are registered trademarks of Lotus Development Corp. Hotshot and Hotshot Graphics are registered trademarks of Symsoft, Inc. Linotronic is a registered trademark of Linotronic AG and/or its subsidiaries. MS and MicroSoft Word are registered trademarks of Microsoft Corp. Apple, Macintosh, LaserWriter Plus, and LaserWriter NTX are registered trademarks of Apple Computer, Inc. OmniPage is a trademark of Caere Corp. TrueScan is a trademark of Calera Recognition Systems, Inc. Type Director is a trademark of Compugraphic Corp. Ventura Publisher is a trademark of Ventura Software, Inc. Visual Edge is a trademark of Intel, Inc. WordPerfect is a registered trademark of WordPerfect Corp. X-ACTO is a registered trademark of Hunt Manufacturing. Xerox is a registered trademark of Xerox Corp.

United States:

For the name of the authorized HP dealer near you, call toll-free 1-800-752-0900. Or contact one of HP's regional offices listed below:

Hewlett-Packard Company
4 Choke Cherry Road
Rockville, MD 20850
301 670 4300

Hewlett-Packard Company
5201 Tollview Drive
Rolling Meadows, IL 60008
312 255 9800

Hewlett-Packard Company
5161 Lankershim Blvd.
No. Hollywood, CA 91601
818 505 5600

Hewlett-Packard Company
2015 South Park Place
Atlanta, GA 30339
404 955 1500

Canada:

Hewlett-Packard Ltd.
6877 Goreway Drive
Mississauga, Ontario L4V1M8
416 678 9430

This document was desktop published with a Macintosh IIfx, a Hewlett-Packard ScanJet Plus scanner, a high-resolution phototypesetter, and desktop publishing software.

Technical information in this document is subject to change without notice.

**Copyright © 1989
Hewlett-Packard Company
Printed in USA 08/89
5952-8085**