

---

# Getting Started Guide



---

## HP Color LaserJet 5/5M Printer

**HP Computer Museum**  
**[www.hpmuseum.net](http://www.hpmuseum.net)**

**For research and education purposes only.**

---

© Copyright  
Hewlett-Packard Company  
1995

All Rights Reserved.  
Reproduction, adaptation,  
or translation without  
prior written permission is  
prohibited, except as  
allowed under the  
copyright laws.

Publication number  
C3961-90901

First edition, October 1995

### **Warranty**

The information contained  
in this document is subject  
to change without notice.

Hewlett-Packard makes no  
warranty of any kind with  
regard to this material,  
including, but not limited  
to, the implied warranties  
or merchantability and  
fitness for a particular  
purpose.

Hewlett-Packard shall not  
be liable for errors  
contained herein or for  
incidental or consequential  
damaged in connection  
with the furnishing,  
performance, or use of this  
material.

---

# Here is where to find the information you need in this guide:

- A Prepare a Location for the Printer**
- B Begin Setup**
- C Check Package Contents**
- D Prepare and Maintain Your Printer**
- E Install the Power Cord**
- F Select the Display Language (Optional)**
- G Install the Print Developers**
- H Install Toner**
- I Load the Paper Tray**
- J Test Printer Operation**
- K Set Power Save Mode (Optional)**
- L Connecting the Printer**
- M Optional Network Configuration**
- N Disabling Network Protocols**
- O Verify Communication between the Computer and Printer**
- P Install the Software Drivers**
- Q In Case of Difficulty**



# Prepare a Location for the Printer

# A

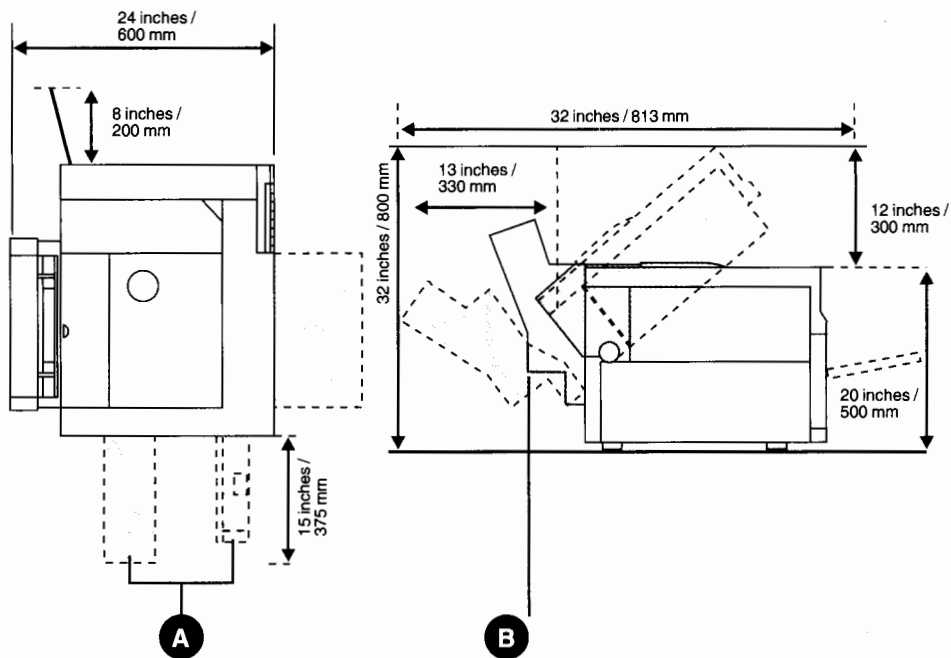

A) Overhead View

B) Side View

## Your location requirements are:

- A sturdy, level surface for placement.
- Space allowance around printer as shown above. (You will need additional space if you have an optional Rear Feed Unit.)
- A well-ventilated room.
- Room temperature 50 to 83° F/  
10 to 28° C.
- Relative humidity 20% to 70%.
- A stable environment with no abrupt temperature or humidity changes.
- No exposure to chemicals or direct sunlight.
- Line voltage and frequency not varying more than  $\pm 10\%$  from the value stated on the printer nameplate (located on the back, opposite the power plug).

**Sufficient space is required for removing maintenance units (A) or clearing paper jams (B), when the optional rear feed unit is installed.**

# B

## Begin Setup

**Save all packing material. You may need to repack and transport your printer at a later date. If you do not save your packing material, please dispose of it responsibly.**

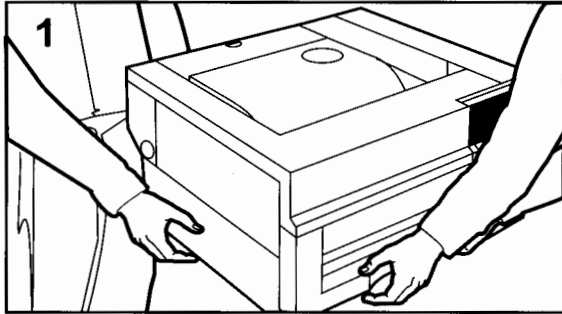

Remove the printer from the box using safe lifting techniques.

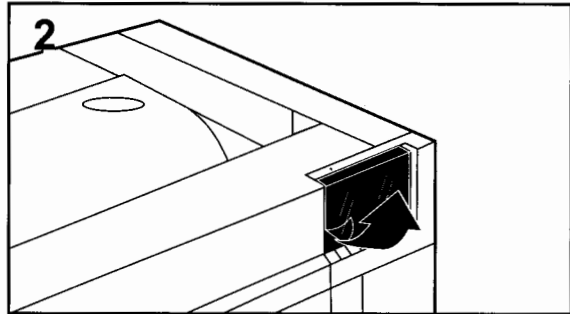

Remove the protective film from the control panel.

### Caution

This printer weighs 102 pounds/46.6 kg. We recommend two or more people to move it.

### Caution

To prevent damage, do not ship this printer with toner or print developers installed.

# Check Package Contents

# C

Locate each item in the list below:

- 1 Printer
- 2 Getting Started Guide
- 3 User's Guide
- 4 Software for the printer
- 5 Printer Server Software Installation Guide (HP Color LaserJet 5M only)
- 6 Toner
- 7 Paper Tray
- 7a Paper Tray Cover (also serves as lower output bin)
- 8 Power Cord
- 9 Front Panel Overlay (not included in the USA)
- 10 Black Developer
- 11 Color Developer

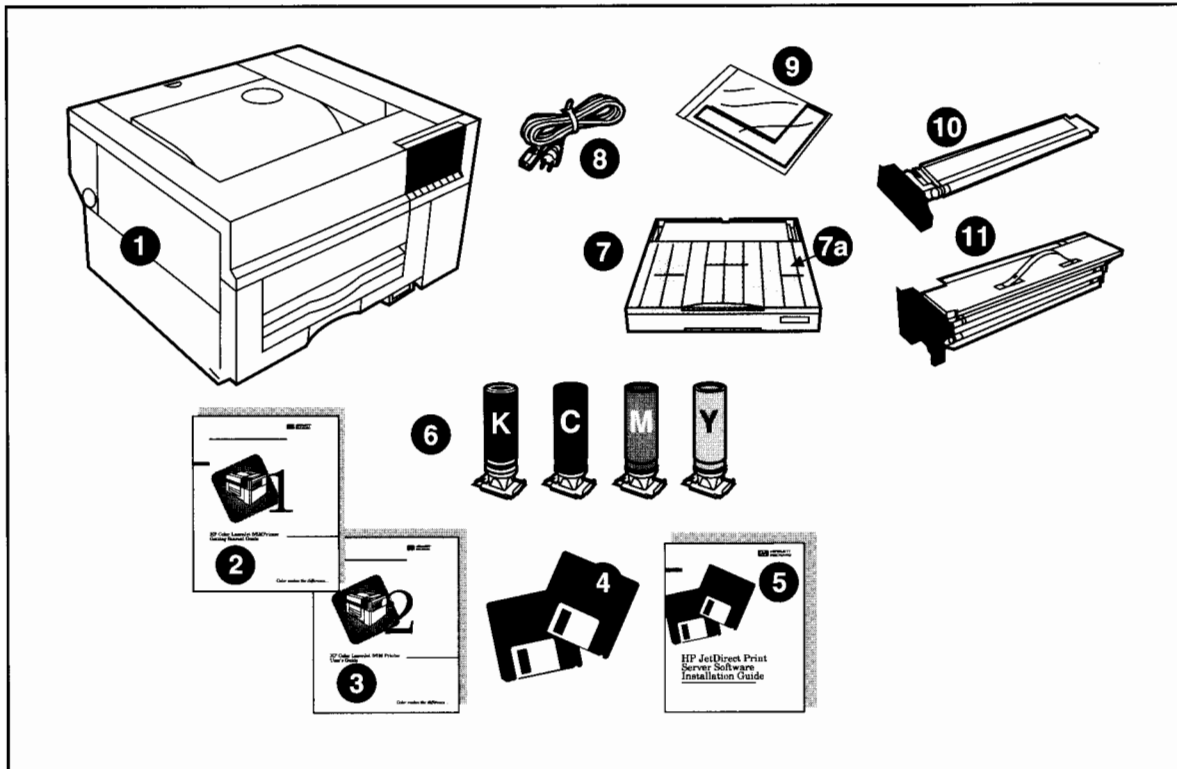



# D Prepare and Maintain Your Printer

Overall print quality will depend largely on keeping certain critical components of your printer clean. Your Color LaserJet 5/5M printer components are especially sensitive to buildup of dust or toner particles. Some of the more sensitive printer components may need to be cleaned after the shipping process.

To ensure the highest possible print quality, clean the following components before using your new printer:

- Optics Glass
- Drum Corona
- Transfer Corona

## Note

For continued optimum printing results, remember to clean the printer on a regular basis (approximately every 2,000 pages).

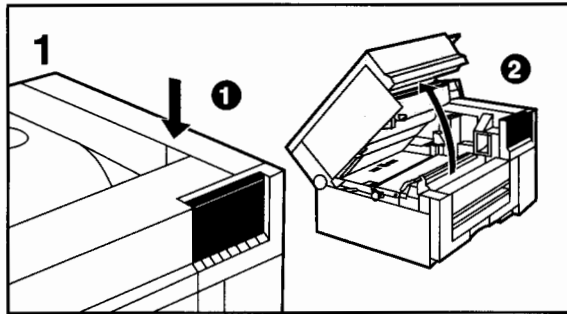

Press the top cover release button (1) and open the top cover (2).

## Caution

Remove all jewelry and watches before continuing. The drum can be easily scratched, causing damage.

Do not expose the print drum to direct light for a prolonged period. This can affect print quality.

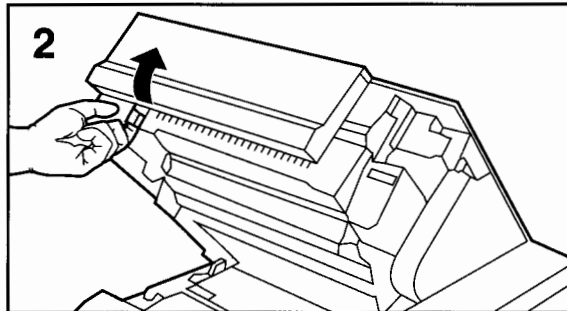

Pull the drum lock lever at the left edge of the drum toward you.

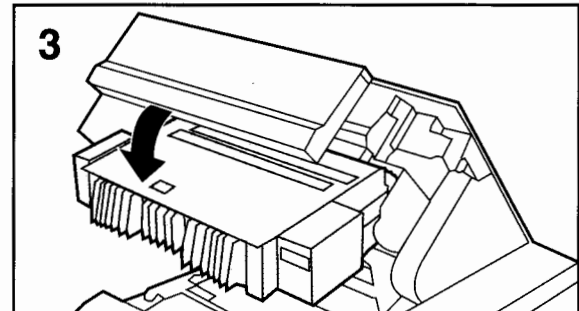

Lower the drum until it is horizontal.

## Prepare and Maintain Your Printer (continued)

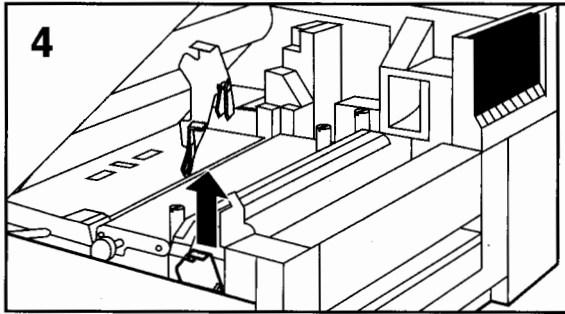

4  
Locate the laser optics cleaning tool above the drum with the padded portion towards the optics glass.

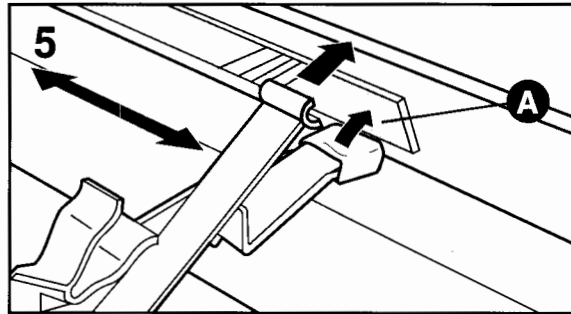

5  
Press the pad on the cleaning tool firmly against the right end of the optics glass (A). Slide the cleaning tool to the left end of the optics glass and back to the right. Return the cleaning tool to its storage place.

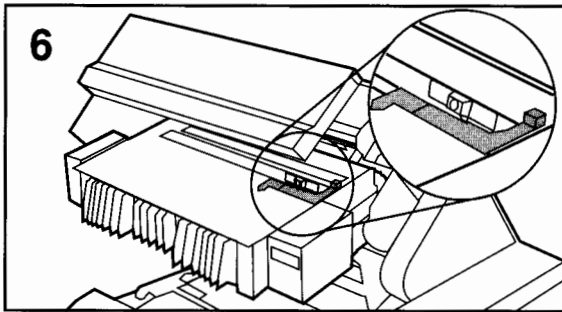

6  
Locate the drum corona cleaning handle toward the back right corner of the drum.

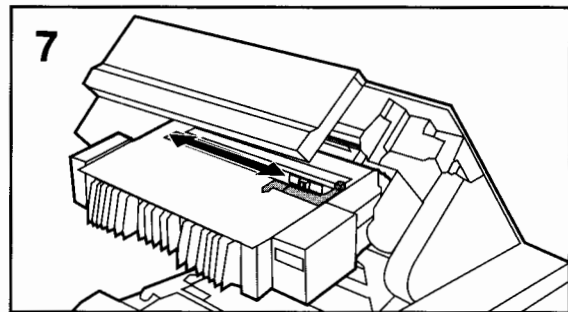

7  
Slide the cleaning handle to the left end of the drum and back to the right. Repeat twice. Return the cleaning handle to its original position.

## Prepare and Maintain Your Printer (continued)

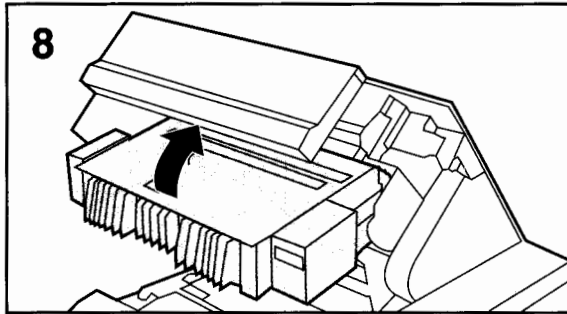

8 Raise the drum until it locks into place.

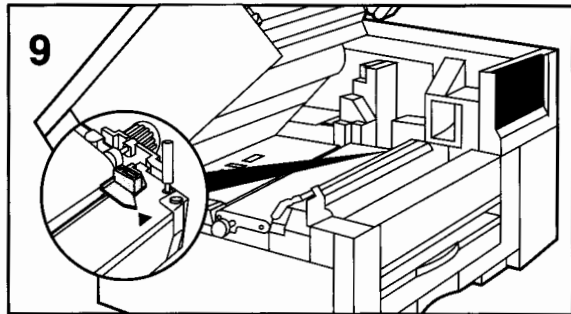

9 Find the transfer corona cleaning knob located between the transfer belt and the fuser on the right side of the printer.

---

### Caution

Do not touch the transfer belt surface. Natural skin oils can reduce the life span of the belt and affect print quality.

---

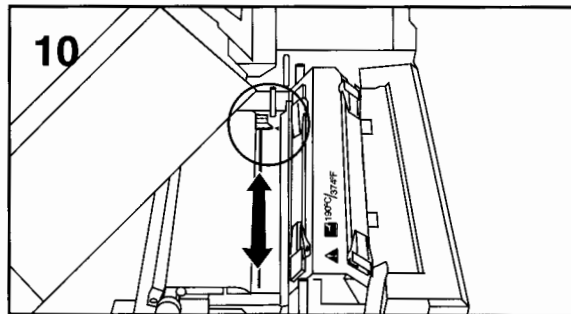

10 Slide the cleaning knob to the left end of the printer and back. Repeat twice. Close the top cover.

---

### Caution

Before closing the printer, be sure the drum corona cleaning handle and transfer corona cleaning knob are seated in the full right position.

---

# Install the Power Cord

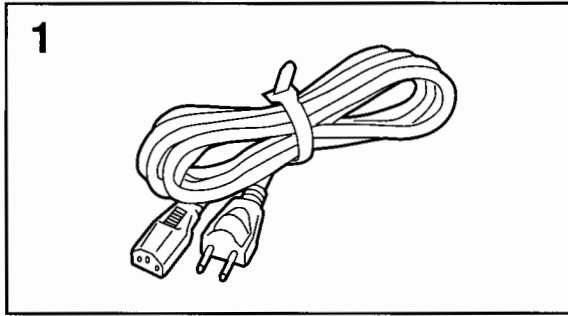

1  
Locate the power cord shipped with your printer.

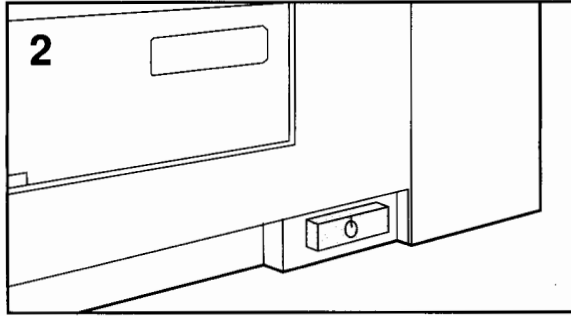

2  
Locate the power switch on the bottom front of the printer.

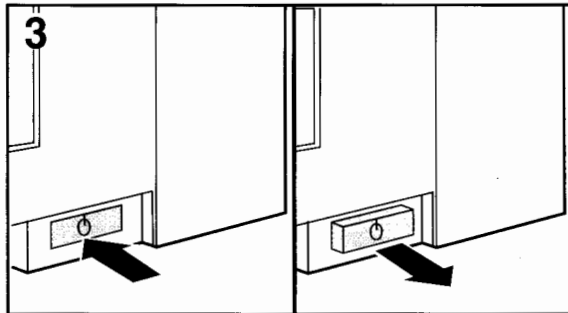

3  
The power switch has two positions: pushed **in** (power ON) and **out** (power STANDBY mode). Make sure the power button is **out** (STANDBY mode).

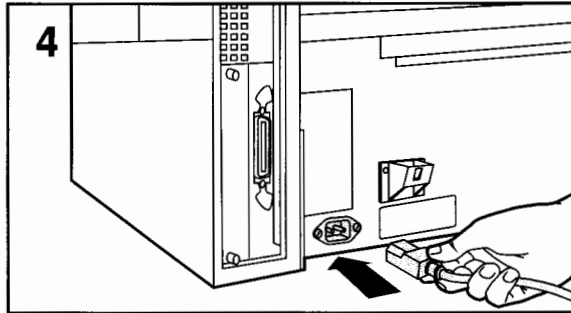

4  
Insert the power cord to the power connector plug on the back of the printer.

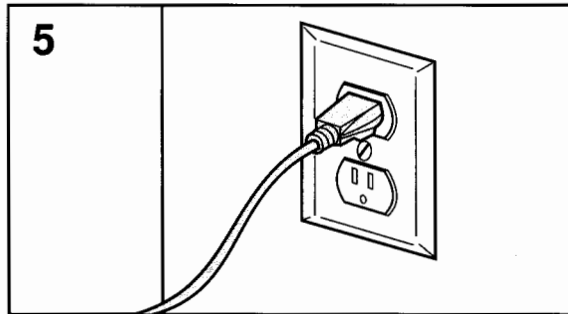

5  
**CAUTION:** Only insert the other end of the power cord into a proper AC power outlet. The printer fan will start.

**If you need to change the display language from English, continue with section F.**

**Otherwise, turn the printer ON, and skip to section G.**

# F

## Select the Display Language (Optional)

Skip this section if you want English as the display language.

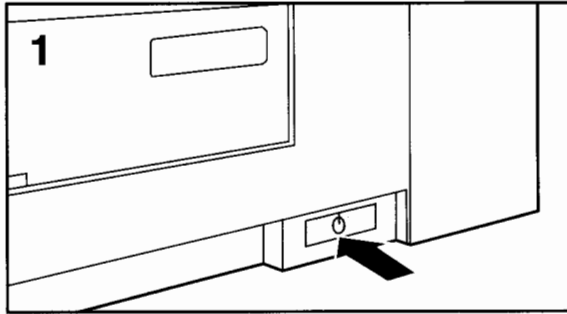

Press and hold **Enter** while pushing the power switch in.

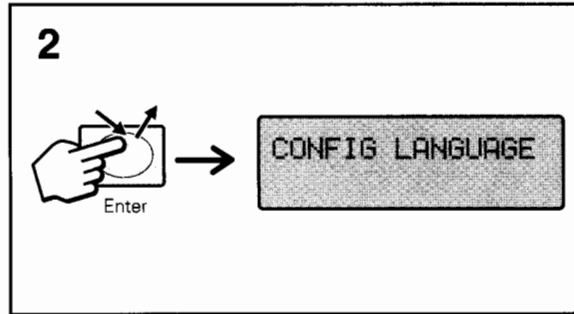

Hold **Enter** until CONFIG LANGUAGE appears. Release **Enter**. 05 SELF TEST appears briefly.

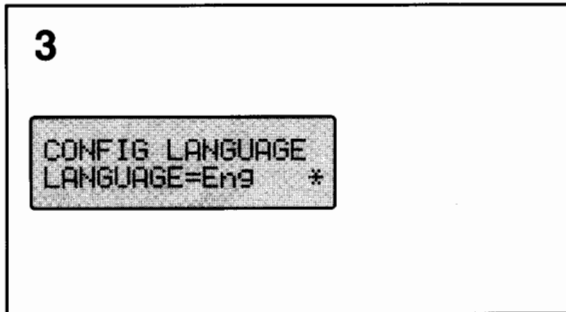

Wait for LANGUAGE=Eng \* to appear. Click **Enter** repeatedly until the desired language appears.

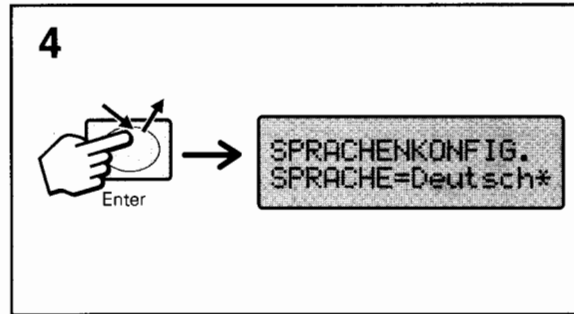

Click **Enter** to save your choice. An asterisk (\*) appears beside your language selection.

### Note

If the new language does not appear in the display, you may not have clicked **Enter** to save your new selection.

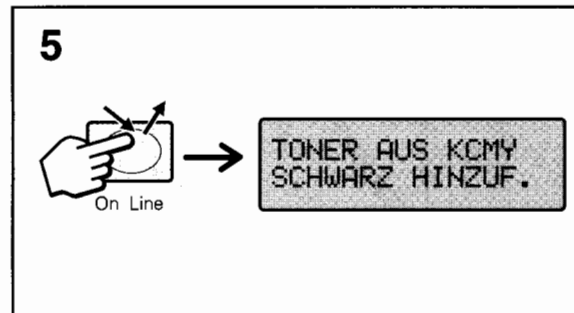

Click **On Line** to return the printer online.

# Install the Print Developers

# G

The Front Panel messages will guide you through the consumables installation process (the printer should be plugged in and the power on).

## Caution

Do not install print developers until you have set up your printer in the location where you will be using it.

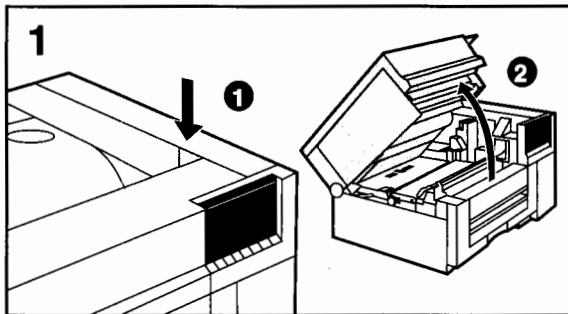

Press the top release button (1), then open the printer's top cover (2).

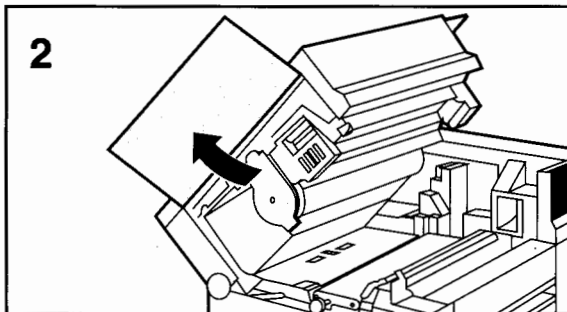

Open the left side cover straight up by grasping its lower edge and lifting it up.

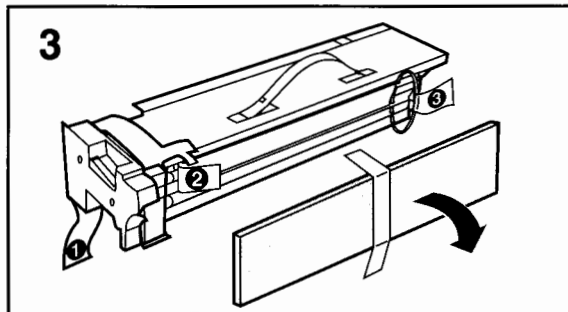

Remove the large foam pad from the color developer.

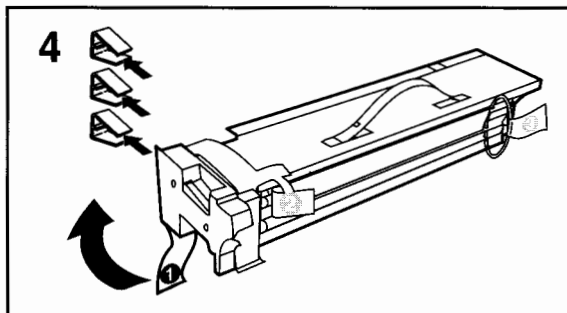

Pull the plastic strip (1) to remove the three clips and foam spacer.

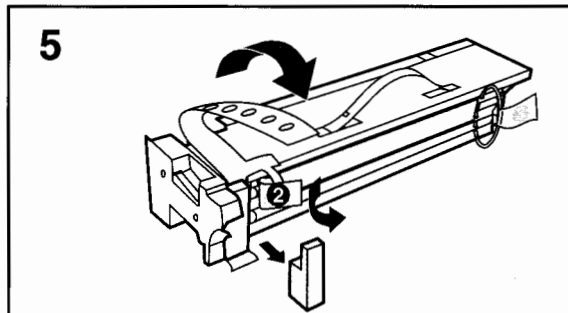

Pull the plastic loop (2) to remove the four plastic strips.

## Install the Print Developers (continued)

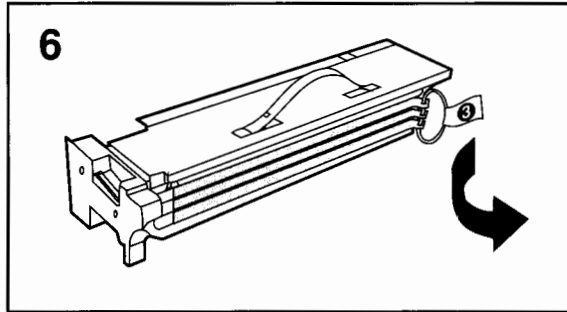

6 Holding the plastic end of the color developer, pull the plastic loop (3) to remove three plastic strips.

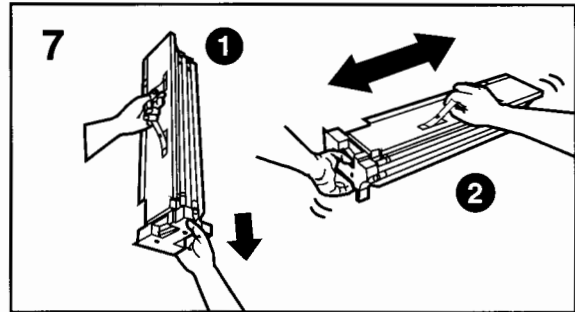

7 Shake the developer (handle end down) from top to bottom and side-to-side several times.

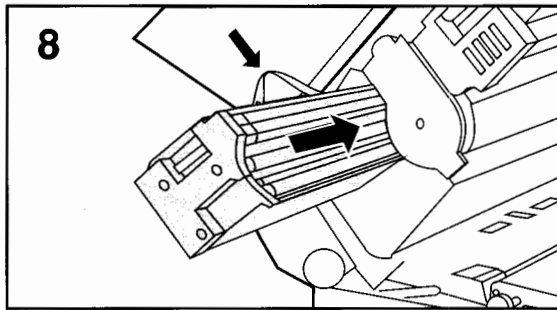

8 Align the color developer with the printer.

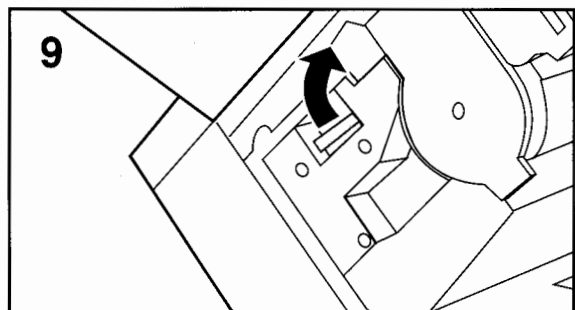

9 Firmly slide the developer into the printer until it clicks into place.

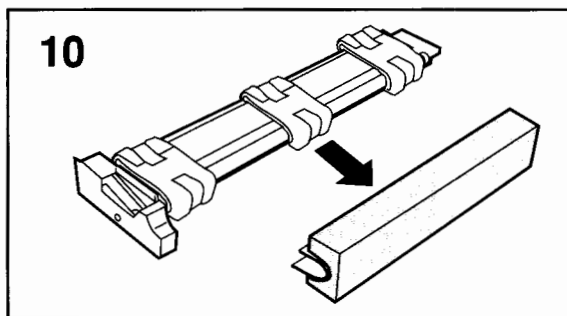

10 Remove the black developer from its packaging. Dispose of the packing materials responsibly.

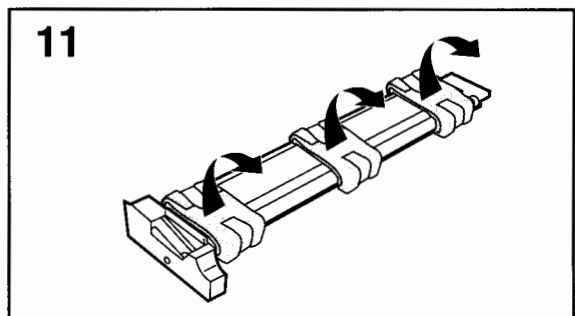

11 Remove the foam covers from the developer.

# Install the Print Developers (continued)

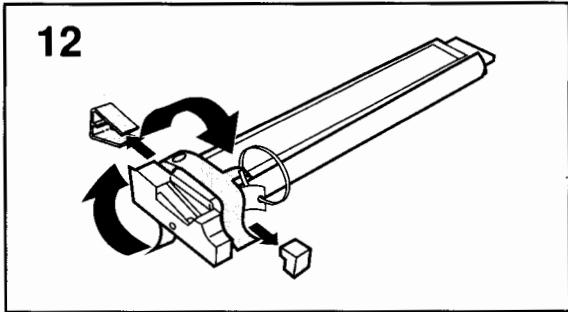

12 Pull the plastic strip to remove the clip and foam spacer.

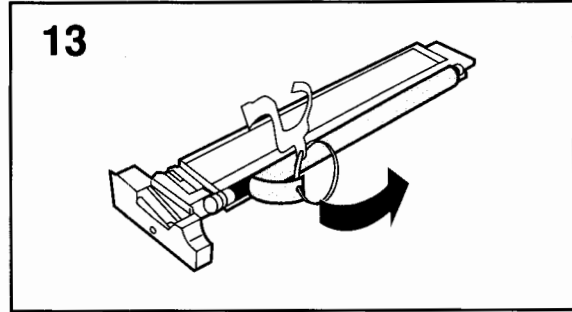

13 Holding the plastic end of the developer, pull the plastic loop.

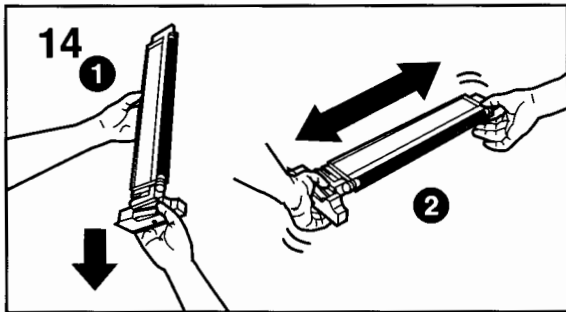

14 Shake the developer (handle end down) from top to bottom and side-to-side several times.

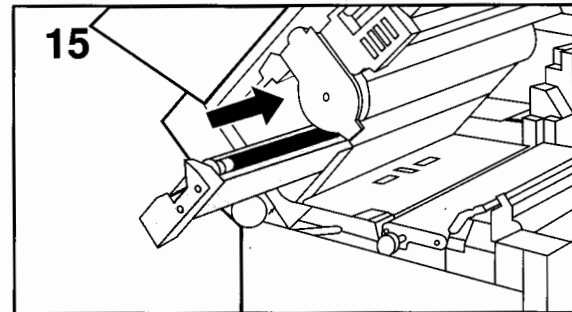

15 Align the developer with the printer.

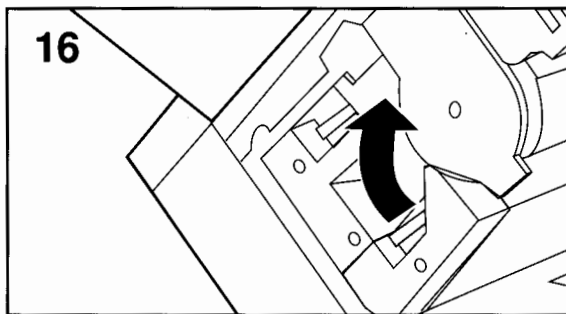

16 Firmly slide the developer into the printer until the release lever clicks into place.

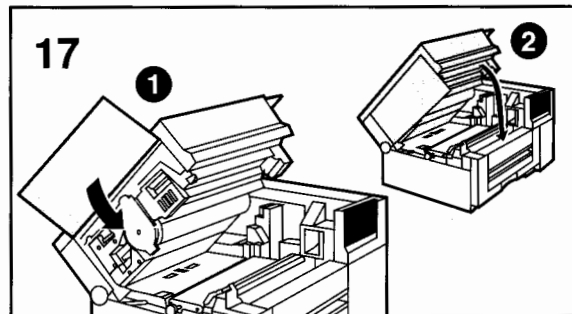

17 Close the printer side and top cover.





# Install Toner

The first time your printer is powered on, you will need to fill all four toner reservoirs in sequence. The letters **KCMY** stand for black (K), cyan (C), magenta (M), and yellow (Y).

## Caution

Do not attempt to load any toner unless the control panel displays a message prompting you to load that color of toner. Loading toner before the printer prompts you may damage the printer.

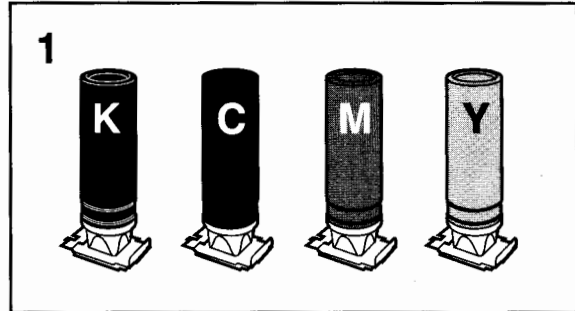

The four bottles indicate the color toner they contain.

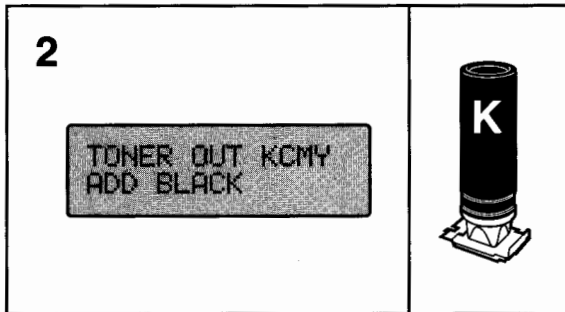

The first color toner to add is BLACK (K).

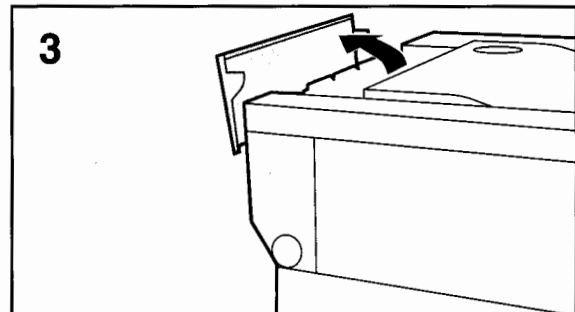

Open the toner reservoir cover.

## Install Toner (continued)

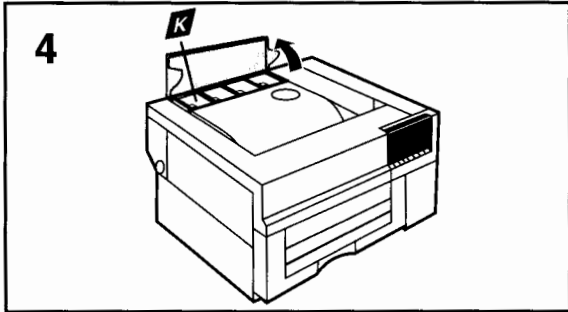

4 Locate the BLACK toner reservoir at the rear of the printer.

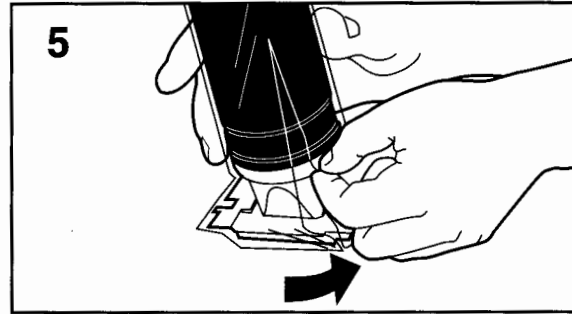

5 Remove the clear plastic wrap from around the toner container.

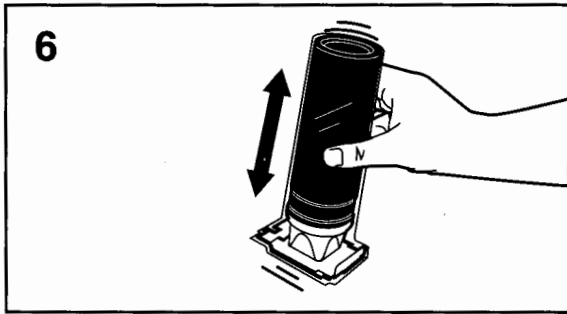

6 Shake the BLACK toner bottle vigorously at least 10 times.

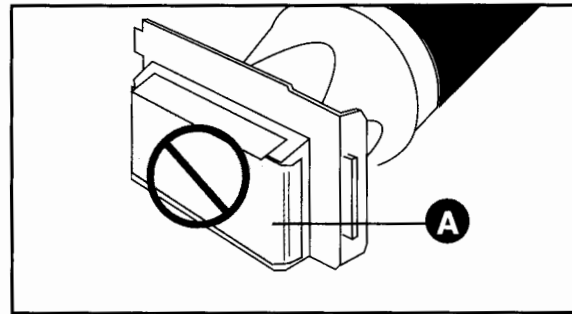

### Caution

Do not remove the clear plastic strip (A) across the bottom of the toner container.

## Install Toner (continued)

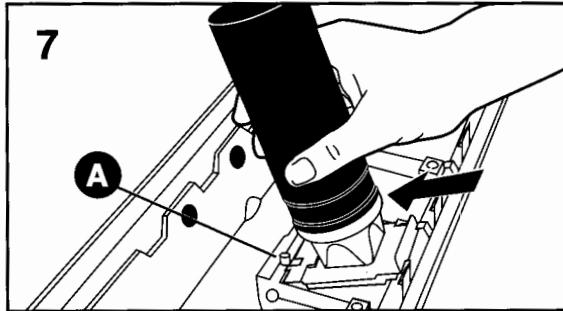

Align the notched end of the toner container with the metal key on the reservoir (A).

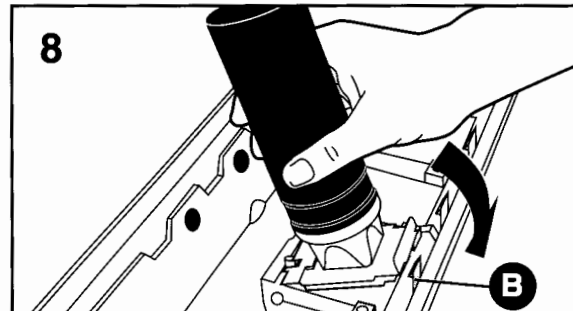

Push the toner container down until it clicks into place under the tab (B).

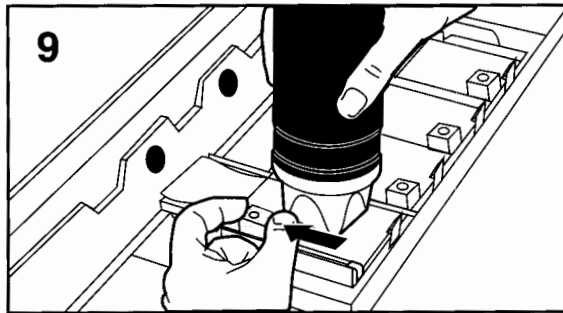

Open the toner door by pushing the release handle back as shown.

### Caution

If the toner door does not open, try re-installing the toner container. Make sure the toner container is properly aligned with the correct reservoir. Hold the toner bottle down with the one hand while opening the door with the other.

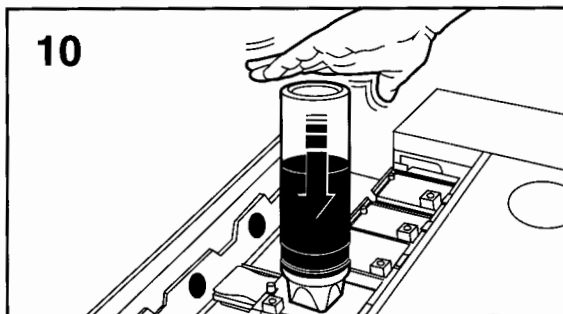

Firmly tap the side of the container several times until it is empty.

### Caution

**DO NOT SQUEEZE THE TONER CONTAINER** to remove toner. Squeezing the toner container can result in toner spillage and damage to the printer.

## Install Toner (continued)

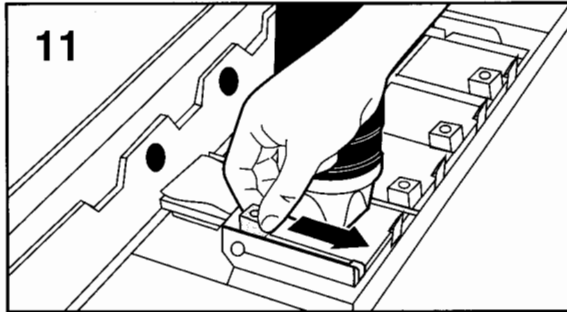

11  
Shut the reservoir door by sliding the release handle toward the front of the printer.

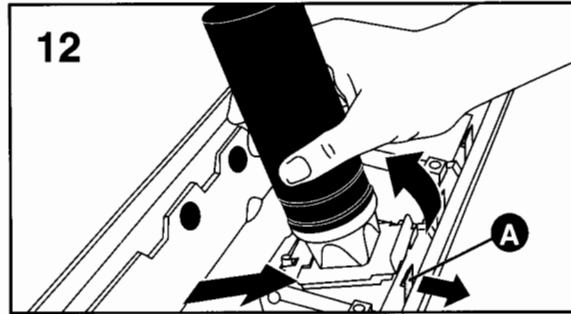

12  
Push the tab (A) toward the printer and remove the empty toner container.

### Caution

Do not force the toner container off. If you have trouble removing the toner container, make sure the toner door is completely closed and the toner container is empty.

Do not shake the toner bottle if excess toner is still in the bottle. This may result in spilled toner.

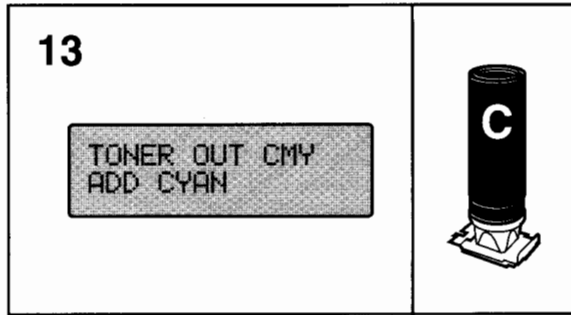

13  
The display panel will now prompt you for the next color in sequence. Repeat steps 4 through 12 to add the remaining toner colors.

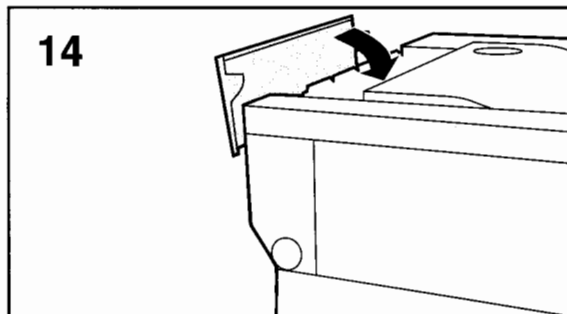

14  
Close the toner reservoir cover .

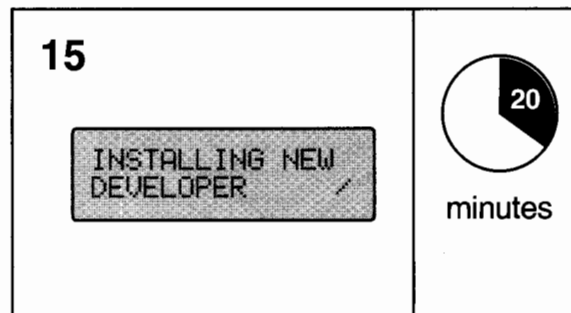

15  
When the last reservoir is filled, click **On Line** . The developers begin initializing. This takes 20 minutes.

# I

## Load the Paper Tray

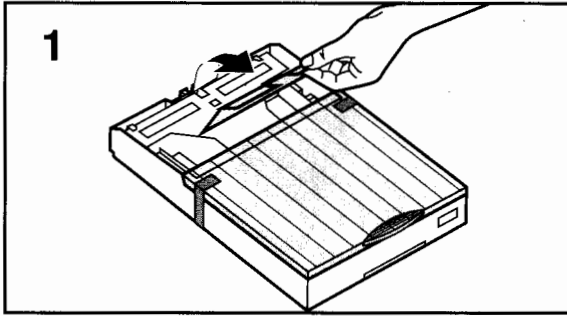

Remove the cardboard and adhesive tape packing materials.

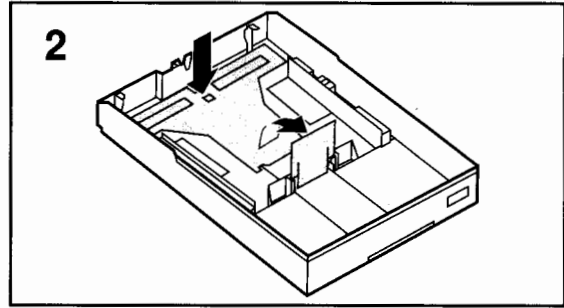

Lift the warning flap, and then press down on the media lift plate until it locks in place.

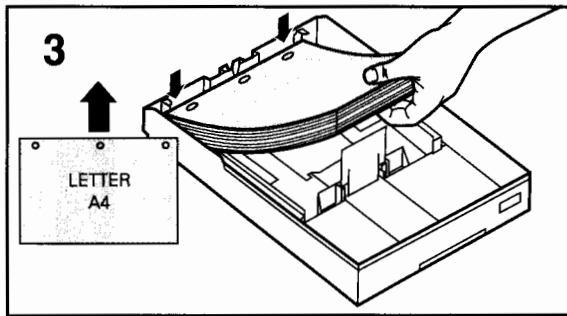

Slide the paper, (Letter and A4) under the metal tabs, long edge forward and print side down.

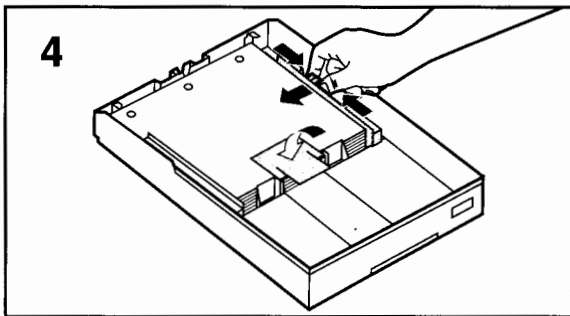

Adjust the width lever firmly against the side of the paper and push the warning flap down.

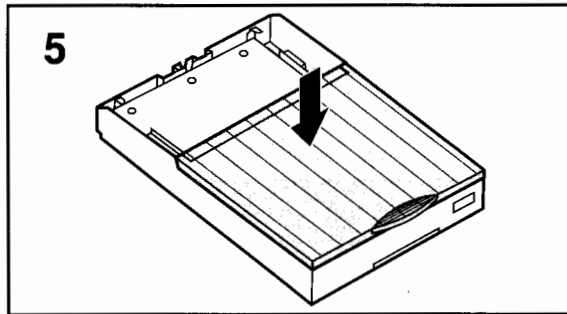

Replace the top of the tray.

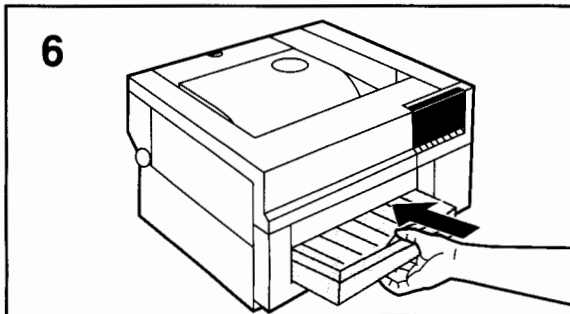

Insert the paper tray into the printer.

# Test Printer Operation

# J

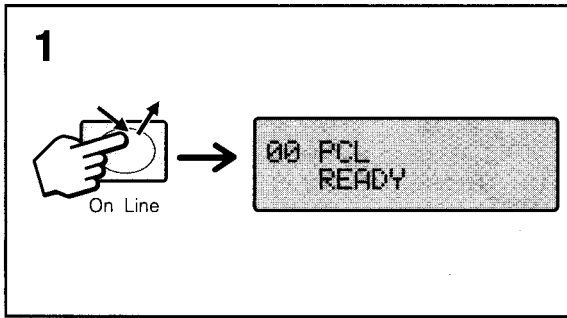

Click **On Line** once to take the printer offline (the On Line indicator goes out).

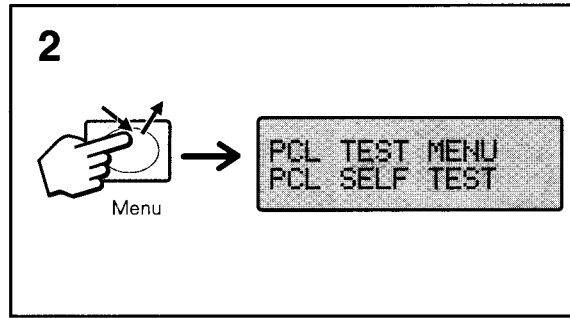

Click **Menu** until PCL TEST MENU and PCL SELF TEST appear.

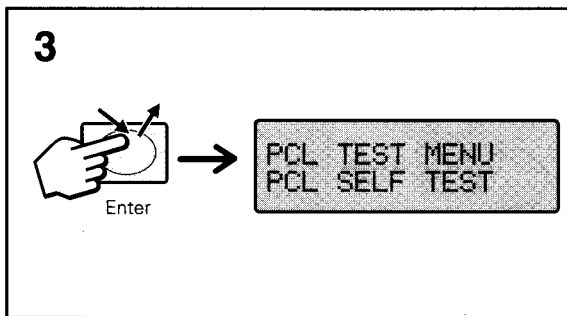

Click **Enter** to print the self test page.

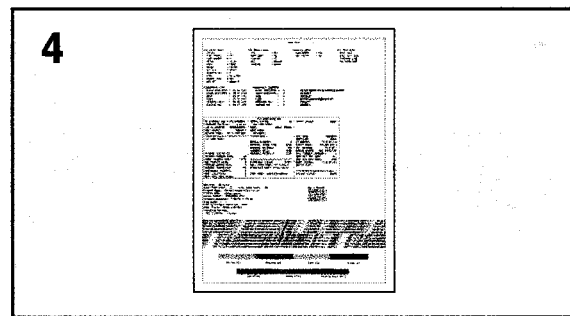

06 PRINTING PCL SELF TEST appears briefly and after about 10 seconds the page prints.

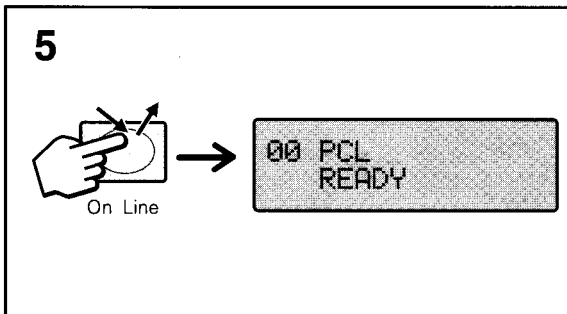

Click **On Line**. 00 PCL READY appears in the display window.

## Note

If an error message appears on the printer display, refer to the “Solving Printer Problems” chapter in your User’s Guide. If problems continue, contact your internal support organization or your HP dealer.

For a detailed description of the self test page and font printout, refer to the “Using the Control Panel” chapter in the User’s Guide.

# K

## Set Power Save Mode (Optional)

Power Save Mode reduces power consumption when the printer is not in use. (Default setting is 60 minutes.) To change or turn off Power Save Mode:

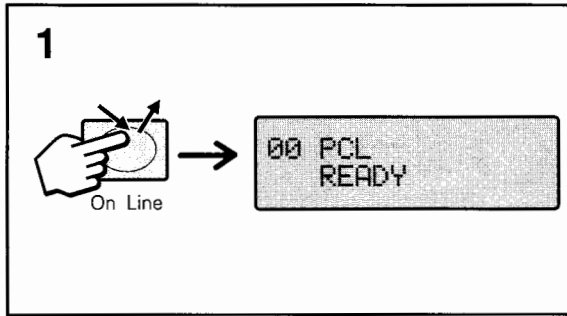

If the printer is online, click **On Line**. The On Line indicator goes out.

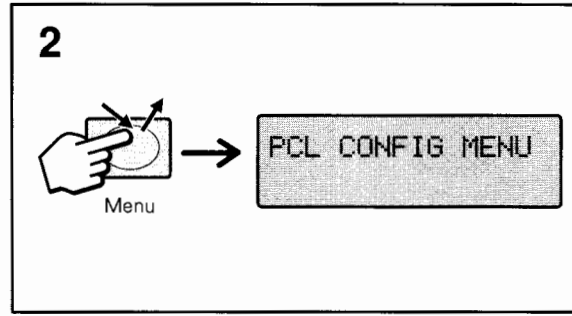

Click **Menu** until PCL CONFIG MENU appears.

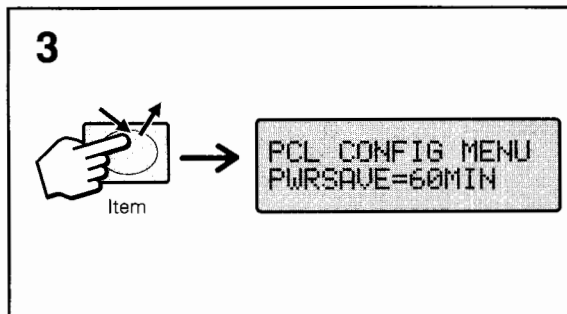

Click **Item** repeatedly until PWRSAVE appears. Default is 60 minutes.

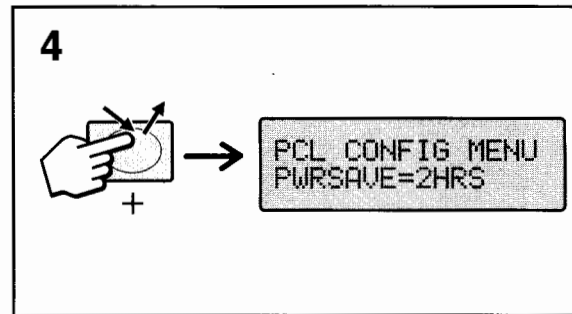

Click **+** to change the time setting between 15 minutes and 3 hours, or OFF.

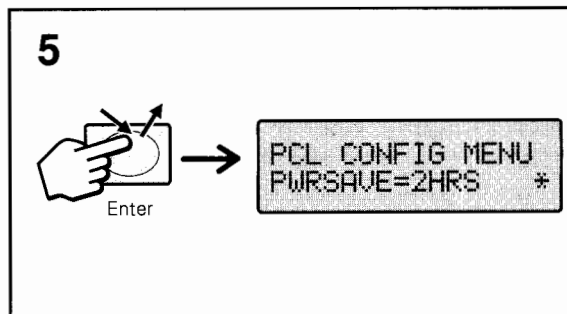

Click **Enter** to save your choice. An asterisk (\*) appears beside your choice.

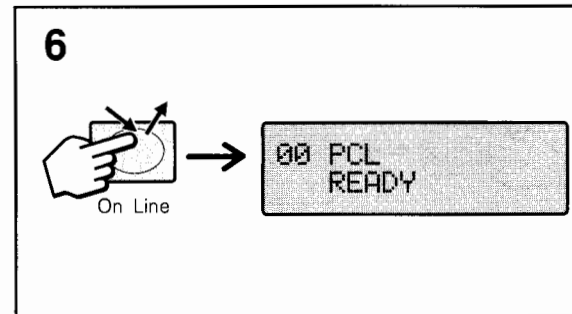

Click **On Line** to return the printer online.

# Connecting the Printer



## Your HP Color LaserJet 5/5M Printer supports up to four different interface connections:

For non-networked PC-compatible computers:

The HP Color LaserJet 5/5M printer comes with a Bi-Tronics parallel port. The Bi-Tronics standard (compatible with Centronics parallel), provides enhanced capabilities, such as bi-directional communication between the computer and printer, and faster transmission of data.

### Note

The cable used to connect the printer to the computer is not provided with the printer. It must be purchased separately.

For networked PC-compatible and Macintosh users:

The HP Color LaserJet 5M has an HP JetDirect print server card with three types of network ports:

- BNC Connector
- 10Base-T Connector
- Din-8 (LocalTalk) Connector

These ports will support EtherTalk/LocalTalk, HP-UX, LAN Manager, LAN Server, NetWare, Solaris, SunOS, Windows for Workgroups, and Windows NT.

### Note

You may attach either a ThinLAN cable or a 10Base-T cable, but not both at the same time.

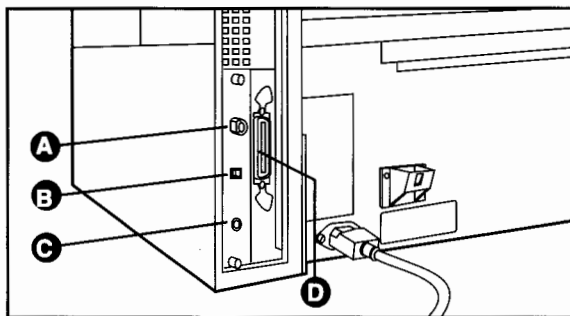

Location of interfaces

- A. BNC Connector
- B. 10Base-T Connector
- C. DIN-8 (LocalTalk) Connector
- D. Bi-Tronics Parallel Connector



Connecting the Printer (continued)

# Bi-Tronics

The illustrations below show you where to insert the cable into your printer port and what the end of the Bi-Tronics parallel cable looks like.

Continue to the next page for more information about your cable. If you have not purchased your interface cable, the information below will help you select the cable.

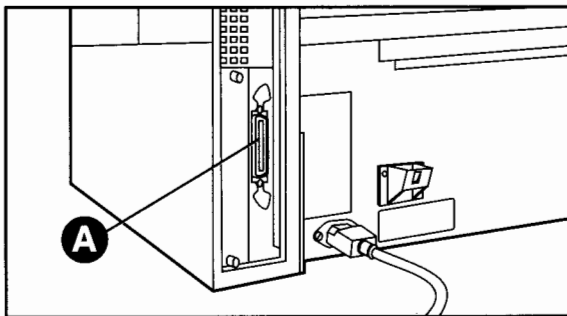

Location of Bi-Tronics parallel port (A) on the back of your printer.

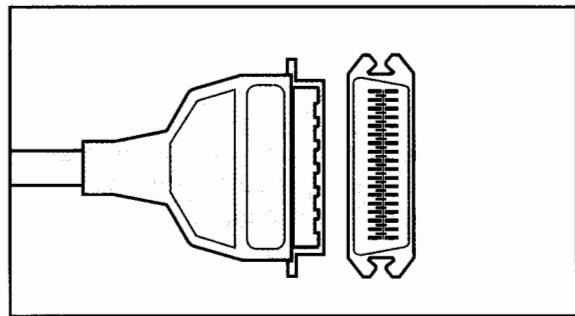

Parallel cable - printer end.

**A typical Bi-Tronics parallel cable specification is:**

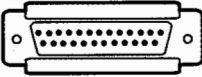
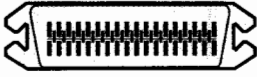
Computers	Computer End	Parallel Interface Cable		Printer End
HP Vectra IBM PC/AT.IXT/PS2 Compaq AT&T and most IBM compatibles	<b>25-Pin Male Plug</b> 	HP Part Numbers HP C2950A HP C2951A	Length 2m 3m	<b>36-Pin Male Plug</b> 

## Connecting the Printer (continued)

# Bi-Tronics

- 1 Make sure your computer is off and your printer is in STANDBY mode (the power switch is **out**).
- 2 Plug the cable into your computer and your printer. Use the wire clips to attach the cable to your printer.
- 3 Turn your computer and printer ON.
- 4 Follow these steps to verify the printer configuration settings.

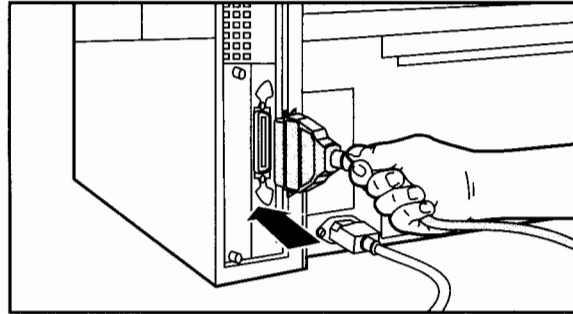

Snap the clips into the notch on the cable connector.

STEP	WHAT to do	HOW to do it	Printer displays
1	Turn printer ON	Press power switch ON	00 PCL READY
2	Take printer off line	Click <b>On Line</b>	00 PCL READY (On Line indicator light goes out)
3	Enter PARALLEL MENU	Click <b>Menu</b> repeatedly until PARALLEL MENU appears	PARALLEL MENU
4	Ensure HIGH SPEED is enabled	Click <b>Item</b> repeatedly until HIGH SPEED=YES * appears	HIGH SPEED=YES *
5	Make sure ADV FUNCTNS is enabled	Click <b>Item</b> once	ADV FUNCTNS=YES *
6	Put printer online	Click <b>On Line</b> once	00 PCL READY (On Line indicator light goes on)

### Note

Print a SELF TEST and keep the printout as a record of your configuration (refer to section **J** for more information).

**Continue to Section O.**

## Network

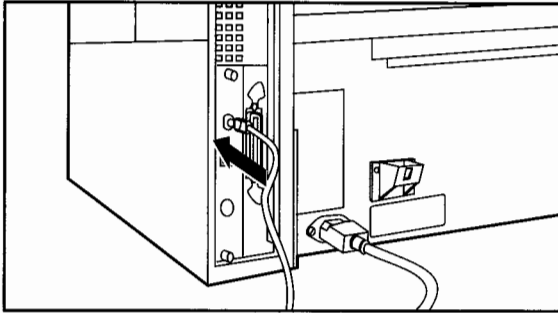

10Base-T Interface Connector

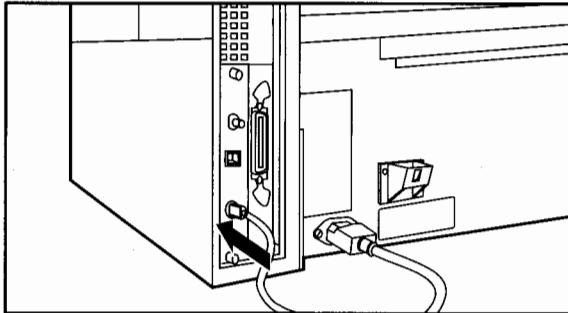

DIN-8 Interface Connection

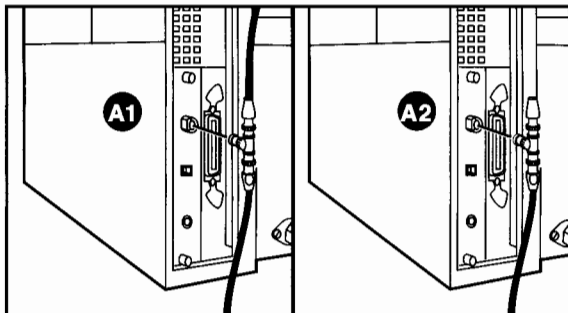

BNC Interface Connection

### 10Base-T Interface

- 1 Plug the connector of your twisted-pair network cable into the 10Base-T jack (RJ-45) on the HP JetDirect card. The other end of the cable should then be attached to a twisted-pair hub/concentrator.
- 2 If you are not connecting other cables, go to Section **M**.

### DIN-8 (LocalTalk) Interface

- 1 Plug the end of your DIN-8 cable into the LocalTalk port on the HP JetDirect card.
- 2 If you are not connecting other cables, go to Section **M**.

---

#### Note

If you are using only the LocalTalk port, `23 MIO NOT READY` will appear every time you turn on the printer. This message will disappear after 3 minutes; if it does not disappear, there is a problem with the card or your network. To stop the message from appearing during normal operation, connect a BNC "T" connector with two 50 Ohm terminators to the BNC port.

---

### BNC Interface

- 1 Attach one section of your ThinLAN cable to one side of the BNC "T" connector.
- 2 Attach another ThinLAN cable section (see A1) or a 50 Ohm terminator (see A2) to the other side of the BNC "T" connector. If you are attaching the printer to the end of your network you must connect a 50 Ohm terminator.
- 3 Attach the BNC "T" connector to the BNC port.
- 4 If you are not connecting other cables, go to Section **M**.

# Optional Network Configuration

# M

Certain network parameters for Novell NetWare, UNIX (HP-UX, Solaris, or SunOS), and EtherTalk networks might need to be set depending upon your network configuration.

Refer to the *HP JetDirect Print Server Software Installation Guide* included with the printer for complete configuration instructions.

Some network parameters can be set from the control panel. The following pages describe those parameters and procedures to set those parameters.

By factory default, all supported network protocols are enabled in your printer. On some networks, these defaults may increase network traffic. To eliminate this traffic, you can disable unused protocols. Disabling unused protocols will:

- Rid the network of unwanted broadcast messages from the printer.
- Prevent unauthorized users from accidentally printing to the network.
- Provide only pertinent information on the self test page.
- Allow the display of warning messages on the printer control panel display for protocol-specific error conditions.

Section **N** lists the procedures for disabling the network protocols.

Software which allows configuration on the supported networks is included with the 5M version of the printer, except for UNIX software (HP-UX, Solaris, or SunOS), which must be purchased separately.

## To select the MIO Menu on the Control Panel

- 1 Click **On/Off** to take the printer offline.
- 2 Click **Menu** until MIO CONFIG MENU appears.
- 3 Click **Item** until CFG NETWORK=NO \* appears. (This message appears even when the network is configured.)
- 4 Click **2** until CFG NETWORK=YES appears.
- 5 Click **Enter**. CFG NETWORK=YES \* appears.

### Configuring Novell NetWare Frame Type Parameters

Selecting a NetWare frame type is not required in most cases. The HP JetDirect card automatically selects a NetWare frame type of "Auto," which allows all listed Novell frame types. The NetWare frame type is displayed on the self test page.

If your network requires a specific frame type, you can set the frame type using the control panel.

To manually configure the Novell NetWare parameters:

- 1 Click **Item** until CFG NOVELL=NO \* appears.
- 2 Click **Item** until CFG NOVELL=YES appears.
- 3 Click **Enter**. CFG NOVELL=YES \* appears.
- 4 Click **Item**. FRAME=AUTO \* appears.
- 5 To configure the Novell NetWare protocol, click **Item** to select one of these frame types:

#### NOVELL NETWARE FRAME TYPES ON AN HP JETDIRECT ETHERNET CARD

Frame Type	Description
<b>AUTO (default)</b>	All listed Novell frame types will be allowed.
<b>EN_8023</b>	Limit frame types to IPX over IEEE 802.3 frames. All others will be counted and discarded.
<b>EN_II</b>	Limit frame types to IPX over Ethernet II frames. All others will be counted and discarded.
<b>EN_8022</b>	Limit frame types to IPX over IEEE 802.2 with Ethernet frames. All others will be counted and discarded.
<b>EN_SNAP</b>	Limit frame types to IPX over SNAP with Ethernet frames. All others will be counted and discarded.

- 6 Click **Enter** to save the selection. An asterisk (\*) appears.
- 7 If other protocols will be used, continue with this section. Otherwise, skip to section **O**

## Configuring TCP/IP Parameters

The HP JetAdmin utility for UNIX (sold separately) may be used to configure TCP/IP parameters. If you do not have the HP JetAdmin utility for UNIX, or you are using a UNIX system other than HP-UX, Solaris, or SunOS, you may use the control panel of your printer to configure these TCP/IP parameters manually:

- Usage of the bootp file for configuration parameters (the default is to use the bootp file)
- IP address (4 bytes)
- Subnet mask (4 bytes)
- Syslog server IP address (4 bytes)
- Default gateway (4 bytes)
- TCP connection timeout (in seconds)

To manually configure TCP/IP parameters:

- 1 Click **Item**. CFG TCP/IP=NO \* appears.
- 2 Click **+**. CFG TCP/IP=YES appears.
- 3 Click **Enter**. CFG TCP/IP=YES \* appears.
- 4 Click **Item** to manually configure TCP/IP parameters.  
BOOTP = YES \* or BOOTP = NO \* appears. If you keep BOOTP = YES \* , then the values for the TCP/IP parameters will be provided by the bootp file, and no other TCP/IP configuration is necessary.
- 5 Click **+** to change the value of the BOOTP = parameter. BOOTP = NO appears.
- 6 Click **Enter** to save the selection.  
BOOTP = NO \* appears.  
If you selected BOOTP = NO \* , then you will be prompted to configure each of the TCP/IP parameters.
- 7 Click **Item** to continue configuring.  
IP BYTE 1 = <value \*> appears.
- 8 Click **+** until the value of the first byte of the IP address appears on the control panel display. Note that if you press and hold **+**. The value will scroll rapidly.
- 9 Click **Enter** to save the value.
- 10 Click **Item** to continue. Repeat steps 8 and 9 to configure the remaining bytes of the IP address.
- 11 Repeat steps 8 through 10 to configure the subnet mask bytes (SM), syslog server IP address (LG), default gateway (GW), and timeout (TIMEOUT) in the same manner.
- 12 If EtherTalk will be used, continue with this section. Otherwise, skip to section N.

### Configuring Apple EtherTalk Phase Parameter

The default setting of Phase = 2 should be adequate for most situations. If you do not want to configure the phase parameter, click **On Line**.

To configure EtherTalk parameters:

- 1 Click **Item**. CFG ETALK=NO \* appears.
- 2 Click **+**. CFG ETALK=YES appears.
- 3 Click **Enter**. CFG ETALK=YES \* appears.
- 4 Click **Item**. Phase = 1\* or Phase = 2 \* appears.
- 5 Click **Item** to retain the value and continue or Click **+** to change the phase parameter.
- 6 Click **Enter** to save the new value.
- 7 Click **On Line**.

You may also want to configure the AppleTalk name and assign a preferred EtherTalk zone. After completing this guide refer to the *HP JetDirect Print Server Software Installation Guide* for further instructions on using the HP software for your network.

# Disabling Network Protocols



- 1 Click **On Line** to take the printer offline.
- 2 Click **Menu** repeatedly until MID CONFIG MENU appears.
- 3 Press **Item** until CFG NETWORK=NO\* appears.
- 4 Click **+**. CFG NETWORK=YES appears.
- 5 Click **Enter**. CFG NETWORK=YES \* appears
- 6 Click **Item** to scroll through each network protocol. NOVELL = ON \* appears.

## To Disable Novell NetWare

- a Click **+** to change to NOVELL = OFF.
- b Click **Enter** to save the new status. NOVELL = OFF \* appears.
- c Click **Item** to continue configuring. DLC/LLC = ON \* appears.

## To Disable DLC/LLC

- a Click **+** to change to DLC/LLC = OFF.
- b Click **Enter** to save the new status. DLC/LLC = OFF\* appears.
- c Click **Item** to continue configuring. TCP/IP = ON\* appears.



## To Disable TCP/IP

- a Click **+** to change to TCP/IP = OFF.
- b Click **Enter** to save the new status. TCP/IP = OFF \* appears.
- c Click **Item** to continue configuring. ETALK = ON \* appears.

## To Disable Apple EtherTalk

- a Click **+** to change to ETALK = OFF.
- b Click **Enter** to save the new status. ETALK = OFF \* appears.

- 7 Press **OnLine** to activate the printer and save your changes.



# O

## Verify Communication between the Computer and Printer

### For HP Color LaserJet 5 printer

To make sure your printer and computer are set up correctly to talk to one another, print out a directory list.

- 1 Make sure your computer and printer are ON and your printer is online. (On Line indicator is lit.)
- 2 At the root directory (A:\> or C:\>) type DIR>PRN and press **Enter**.
- 3 If the list of files prints without problem, printer setup is complete. Now you can set up your software to work with your printer. Refer to application help notes, provided with your software driver disks, for information on installing your driver and selecting a printer in your application.
- 4 If nothing was printed, and the printer's control panel does not display an error message, read through the troubleshooting checklist (section Q) for help in solving the problem.
- 5 If an error message appears in the printer control panel display, refer to the "Solving Printer Problems" chapter in your User's Guide for information. Then, read through the troubleshooting checklist (section Q) for help in solving the problem.

### For HP Color LaserJet 5M (or HP Color LaserJet 5 with a PostScript SIMM)

To verify PostScript printing capabilities, and to verify communication between MS-DOS and your printer:

- 1 Make sure your computer and printer are turned ON and your printer is online.
- 2 At the MS-DOS prompt (A:\> or C:\>), type **Edlin Test.PS** and press **Enter**. Then perform the following steps:
  - a At the asterisk (\*), type **1i** (the number "one" and the letter "i") and press **Enter**.
  - b At the 1:\*, type **clippath stroke showpage** and press **Enter**.
  - c At the 2:\*, hold the **Control** key down and press D.
  - d At the asterisk (\*), type **E** and press **Enter**.
  - e At the DOS prompt (:>), type **Copy Test.PS LPT1:** and press **Enter**.

The Form Feed indicator will flash to indicate the printer has received this data. A page with a border surrounding the image area will print.

# Install the Software Drivers

P

Before you can use the printer with your applications, you must install the current HP printer software that was shipped with your printer.

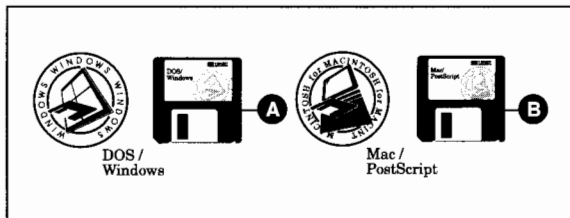

Check the disk labels to select the printer software disk(s) appropriate to your system (Windows, DOS, Macintosh, PostScript etc.).

Install the software by following the instructions on the disk labels or on the instruction insert enclosed.

## Note

If you are installing a network printer, follow the instructions found in *HP JetDirect Print Server Software Installation Guide* after you complete this guide.

## What if I have problems with my printer driver?

For wrong disk size, damaged, or lost software, call the HP Distribution Center at (303) 339-7009. US Only.
For 24 hour automated support answers to common problems, call HP Audio Tips at (800) 333-1917. US Only.
For assistance with technical questions regarding HP printer drivers, call the HP Customer Support Center for the US and Canada, call (208) 323-2551 from 7 a.m. to 6 p.m. (MT) Monday through Friday, except Wednesday when the hours are 7 a.m. to 4 p.m. (MT). For other countries, refer to the flyer in the printer box for a list of the Customer Support Center phone numbers.

## Where can I obtain drivers not included with this printer:

Source	Description
<b>Your software vendor</b>	Most popular software packages have drivers available for this printer. You may contact your software vendor to order an updated printer driver for your printer.
<b>CompuServe</b>	The fastest way to receive HP printer drivers is by downloading them to your computer from the HP Forum on CompuServe. To sign up for CompuServe call (800) 848-8199 and ask for Representative #51. US Only. (NOTE: This service not operated by HP.)
<b>HP Distribution Center</b>	To order HP printer drivers by phone, call HP Distribution at (303) 339-7009. US Only.
<b>HP FIRST</b>	For 24 hour access to information on how to order HP printer drivers, call HP FIRST at the following numbers. This information is sent to you by fax. For countries which are not listed, contact your local HP dealer.

Country	Phone Number
US	(800) 333-1917 or (208) 344-4809
United Kingdom	0-800-96-02-71
Netherlands	06-02-22-420
Belgium	078-11-19-06
Belgium (French)	078-11-70-43
English outside of UK	(31) 20-681-5792
Germany	0130-8100-61
France	05-09-5900
Switzerland (German)	155-1527
Switzerland (French)	155-1526
Austria	0660-8128



## In Case of Difficulty

### Troubleshooting Checklist:

- Is the On Line indicator on the printer control panel lit?  
If not, click **On Line**.
- Did you set up the control panel correctly?  
Check to make sure you entered the correct interface selections into the control panel. Repeat the procedure in section L for a Bi-Tronics parallel interface, or go to the instructions that came with the interface you are using.
- Was your computer or printer ON when you connected the interface cable?  
Turn the computer and printer OFF. Wait 15 seconds, then turn them ON again.
- Is your printer working correctly?  
Print the Self Test described in section J. If necessary, call your HP dealer or HP sales representative.
- Have you installed the HP Color LaserJet 5/5M printer driver? Refer to section P.

### If You Still Need Help...

- Consult your *HP Color LaserJet 5/5M Printer User's Guide*.
- Call the HP Dealer from whom you purchased your printer.
- Call Hewlett-Packard Customer Support.



