

MODEL
5

 **HEWLETT-PACKARD
9805A STATISTICS CALCULATOR
OPERATING GUIDE**

Introduction

The 9805 Statistics Calculator provides the user with basic statistical calculations at the touch of a key. From mean and standard deviations to curve fitting, the Statistics Calculator simplifies statistics by:

- preserving data once it has been entered regardless of the number of calculations.
- providing a printed record of all data entries and all calculations.
- permitting the addition or deletion of data at any time during calculations.
- identifying statistical output with accepted statistical symbols.

In addition, the 9805 will solve math problems involving logs, exponents, percentages, squares, and square roots. After trying it once, you'll wonder how you ever managed without it.



9805A Statistics Calculator Operating Guide



Copyright by Hewlett-Packard Company 1973



HEWLETT-PACKARD CALCULATOR PRODUCTS DIVISION
P.O. Box 301, Loveland, Colorado 80537, Tel. (303) 667-5000
Rue du Bois-du-Lan 7, CH-1217 Meyrin 2, Geneva, Tel. (022) 41 54 00

Table of Contents

Introduction

Chapter 1: Getting Started

Preliminaries	1
Keying In Numbers	1
Clearing Numbers	1
Simple Arithmetic	2
Constant Storage	3
Using Negative Numbers	3
The Busy Light	4
Printer	4
Display Option	4

Chapter 2: Basic Statistics

DATA ENTRY	5
BASIC STAT	5

Chapter 3: Histograms

OFFSET-WIDTH	7
DATA ENTRY	7
DELETE	8
HISTO	8
BASIC STAT	10
Data Storage Locations	11

Chapter 4: Curve Fitting-Linear & Parabolic

DATA ENTRY	13
DELETE	13
LINEAR	13
PARA	13
\hat{Y} EVAL – Linear Estimate	15
PLOT	15
\hat{Y} EVAL – Parabolic Estimate	16
PLOT	16
BASIC STAT	16
Data Storage Locations	17

Chapter 5: Two-Sample t

DATA ENTRY	19
DELETE	19
t	19
Data Storage Locations	22

Chapter 6 Paired t

DATA ENTRY	25
DELETE	25
t	25
BASIC STAT	28
Data Storage Locations	28

Chapter 7: Plotting the Histograms

X Axis Range	31
Y Axis Range	31
Tic Mark Intervals	31
Axes Intercept Coordinates	31
PLOT	32

Chapter 8: Plotting Curve Fits and Data Points

X Axis Range	35
Y Axis Range	35
Tic Mark Intervals	35
Axes Intercept Coordinates	35
Individual Data Points	36
Curve Fits	36

Chapter 9: Additional Math Functions

Rounding	43
What's Scientific Notation	44
Accumulating Results	44
Using Parentheses	45
Numbers to Powers	47
Percentage Calculations	49
Special Functions	50
Divide By 12	51
Reciprocal Value	51
Logarithms	52
Automatic Decimal Point	54

Appendix A: Turn-On Procedure

Accessories	55
Initial Inspection	55
Turn-On Procedure	56

Appendix B: Operating Limits

Accuracy	59
Calculating Range	59
Operating Errors	59
Temperature Range	59
Accuracy of the Parabolic Coefficients	60

Appendix C: Calculator Service

Calculator Checkout Procedure	61
Replacing Printer Paper	68
Replacing Printer Ribbon	69
Cleaning the Printer	70
Cleaning the Calculator	71

Appendix D: Operating Information

t Table	75
Notation and Formulas	76

Glossary

Operating Notes

Keyboard Fold-out

CAUTION

THE 9805 STATISTICS CALCULATOR CAN BE SEVERELY DAMAGED IF IT HAS NOT BEEN SET TO THE CORRECT VOLTAGE; IF IN DOUBT, PLEASE REFER TO APPENDIX A.

We make no express or implied warranty of any kind, including, but not limited to, the implied warranties of merchantability and fitness for a particular purpose, with regard to the programs used in the 9805 Statistics Calculator. HP shall not be liable for incidental or consequential damages in connection with or arising out of the furnishing, performance, or use of these programs.

Preliminaries

Your 9805 Statistics Calculator is shipped fully assembled and is ready to operate after making a few simple checks. If you have just received your calculator, please be sure to immediately inspect it before switching it on (refer to Appendix A of this manual for both inspection and turn on procedures). But if the calculator has already been running in your area, simply do the following:

- If the calculator is not plugged in, plug one end of the power cord into the rear panel of the calculator; plug the other end into a suitable power outlet.
- If the calculator is switched off, check to see that the two-position switches **PRT OFF** and **AUTO** are in the up position. Then press and lock the switch marked **LINE**. The word '**CLEAR**' should be printed; if it is not, see Calculator Service, Appendix C.

Keying In Numbers

Key in numbers from left to right and include the decimal point if it is a part of the number. For example, the number 314.32 would be keyed in as:

3 1 4 . 3 2

Clearing Numbers

When you wish to erase the number you're keying in (perhaps you keyed it in wrong) press **CANCEL ENTRY** and key it in correctly. To erase the previous problem, press **CLEAR**. The word '**CLEAR**' is printed.

Simple Arithmetic

To solve arithmetic problems with your Statistics Calculator:

1. enter the first number;
2. press the operation (+, −, ×, ÷) you want to do;
3. enter the second number;
4. press = (the letter 'R' is printed with each result).

The calculator prints your keyboard operations as you key them in.

Examples Before doing these examples, be sure **PRT OFF** and **AUTO-** are not pressed down.

To add \$5.98 and \$.29:

Press: **CLEAR**

Then press: 5.98 **+** .29 **=**

```

CLEAR
5.98 +
.29 =
6.27 R
  
```

Take a moment to notice how the calculator records your keyboard operations. Each number is printed after an operation key is pressed; then the result of the problem (R) is printed after pressing =.

Subtraction: $31 - 8 = ?$

Press: 31 **−** 8 **=**

```

31.00 −
8.00 =
23.00 R
  
```

Multiplication and Division: $\frac{35 \times 4}{.4}$

Press: 35 **×** 4 **÷** .4 **=**

```

35.00 ×
4.00 ÷
.40 =
350.00 R
  
```

Whenever you wish to keep a printout for later use, press **PAPER↑** and tear the paper off.

When working problems with more than two numbers, the calculator uses the result of the previous operation to perform each new operation. No subtotals are printed. Thus, when you pressed **÷** in the last example, the product of 35×4 was calculated (but not printed) and then that product was divided by $.4$. The final answer was printed when you pressed =.

For example, to add this list of numbers:

12	
45	
8	
23	
6	
89	
	?

Press: 12 $\boxed{+}$ 45 $\boxed{+}$ 8 $\boxed{+}$

23 $\boxed{+}$ 6 $\boxed{+}$ 89 $\boxed{=}$

```

12.00 +
45.00 +
8.00 +
23.00 +
6.00 +
89.00 =
183.00 R
  
```

Constant Storage

To store a number for later use, key in the number and press **STORE**. You can also store the result of a problem by pressing **STORE** after the result is calculated. A stored constant remains unchanged until either another number is stored or the calculator is switched off.

To use the stored constant in a problem, just press **RECALL** instead of keying in the number.

Using Negative Numbers

Negative numbers are entered by keying in the number and then changing its sign by pressing $\boxed{\text{SHIFT}} \boxed{(-)}$ CHS.

For example, to solve this problem:

Press: 35 $\boxed{\times}$ 5 $\boxed{\div}$ 2

$\boxed{\text{SHIFT}} \boxed{(-)}$ $\boxed{=}$
CHS

```

35.00 x
5.00 ÷
2.00 =
87.50 R
  
```

Remember that the sign must be changed after the number is entered. Also, notice that negative numbers are printed in red.

The Busy Light

The small red light that flashes in the display window is the Busy Light. When you're running internal programs or doing keyboard calculations, the busy light may stay on for up to a few seconds. The busy light is there to remind you that the calculator will ignore any keys you press while it's working your problem. In most cases, the calculating time includes time for the printer to record your keyboard operations. So, if you wish to do 'chain calculations' as fast as possible, switch the printer OFF by pressing **PRT OFF** down – you can still print the number just keyed in, or the current result, by pressing **PRINT**.

Printer



The printer provides a written record of all calculations, using an easy-to-understand notation for each function. In addition, the calculator lets you know of operating errors by printing a special 'NOTE' after an error is made. When a note is printed, you should compare it with the list in Appendix D. You'll find that most errors can be easily corrected by simply keying in the problem correctly.

Display Option

The display allows the operator to see each number as it's entered or to see the result just calculated. Each number is displayed in the same form that it is printed. If your calculator has the optional display, it should appear like this whenever the calculator is switched on:



One of the most basic statistical calculations is to find the mean and standard deviation of a single group of numbers.

To set up a one-variable problem press   . This erases the machine of previous data and prepares it for the entry of a single array. If, by accident, you press the **VAR#** key in the middle of a problem, follow it with a numerical key greater than 2 in order to retain the current data and problem. An Operating Note is printed, but in this case you can ignore it and continue with the problem.



Key in each number and follow it with **DATA ENTRY**. Each entry is automatically printed. If you find you have made a mistake, or if you want to delete a data value at some later time, it can easily be corrected. Press **DELETE**, key in the unwanted entry, and then press **DATA ENTRY**. Data can be added or deleted at any time. The statistical summations of the data are preserved regardless of the number of calculations.



Pressing **BASIC STAT** calculates the sample size, mean and standard deviation* of the data and prints it in the following form:

sample size (N)
mean (\bar{x})
standard deviation (Δ)



Example

In a recent survey to determine the average age of the 10 wealthiest people in Monte Carlo, the following data was obtained:

62 84 47 58 68 60 62 59 71 73

*The formula used for calculating the standard deviation is included in Appendix D.

Of the ages given, what is the mean and standard deviation?

Press: VAR# 1
 62 DATA ENTRY 84 DATA ENTRY 47 DATA ENTRY
 58 DATA ENTRY 68 DATA ENTRY 60 DATA ENTRY
 62 DATA ENTRY 59 DATA ENTRY 71 DATA ENTRY 73 DATA ENTRY

```

V1 .....
62.00 #
84.00 #
47.00 #
58.00 #
68.00 #
60.00 #
62.00 #
59.00 #
71.00 #
73.00 #
  
```

BASIC STAT
 sample size →
 mean →
 standard deviation →

```

N =
10.00 #
x̄ =
64.40 #
s1 =
10.10 #
  
```

Delete the highest and lowest age. What is the new mean and standard deviation?

Press: DELETE 47 DATA ENTRY
 DELETE 84 DATA ENTRY
 BASIC STAT

```

D E L
47.00 #
D E L
84.00 #
N =
8.00 #
x̄ =
64.13 #
s1 =
5.74 #
  
```

The mean, for all practical purposes, is the same. The standard deviation, on the other hand, has been cut nearly in half.

Chapter 3 Histograms

To set up a histogram first press $\text{VAR} \blacksquare$ 1 . All previous data is erased.



The 9805 Statistical Calculator groups data for each histogram into ten cells. The offset defines the lower boundary of the first cell. The cell width defines the width of each cell. (See drawing.)

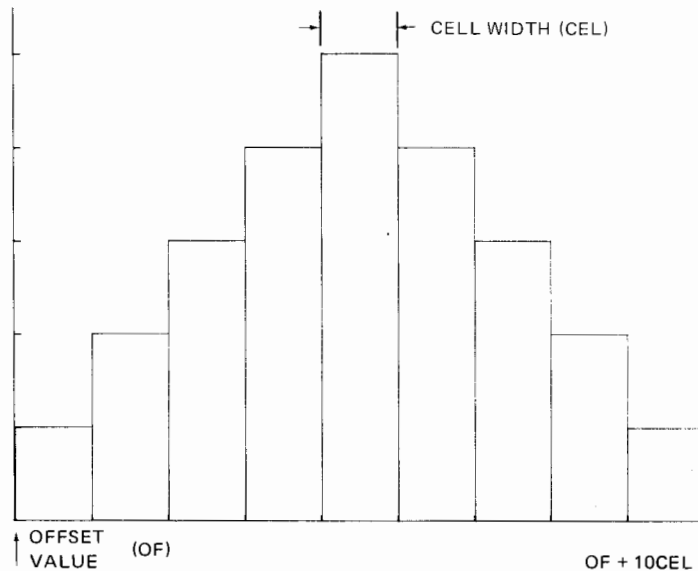

To define the offset and cell width, first press OFFSET WIDTH . Key in the offset value and press **DATA ENTRY**. Then key in the cell width and press **DATA ENTRY** again.



Key in each data value and press **DATA ENTRY**. Each entry is automatically printed. Data included in the histogram must fall in this range:

$$\text{offset} \leq \text{data} < \text{offset} + 10 \times \text{cell width}$$

If the value does not fall into one of the 10 cells, as described by the above range, the letter L (for too 'low') or H (for too 'high') is printed above the number on the printout.



If you find you have made a mistake, or if you want to delete a data value, at some later time, the procedure is simple. Press **DELETE**, key in the unwanted entry, and press **DATA ENTRY**. The number of entries is shown in the optional display after each entry or operation.

Data can be added or deleted at any time. The statistical summations of the data are preserved regardless of the number of calculations.



Pressing the **HISTO** key calculates and prints the following information for each of the 10 cells:

- cell number
- lower boundary of the cell
- frequency of the cell
- relative percent frequency of the cell

Example

The data set below represents the weights of canned tuna produced at a cannery. The cans coming off the production line were randomly sampled hourly. 27 cans were selected and weighed from one packing machine.

Weights: 113.3 112.1 115.6 114.1 117.2 116.1 117.1 116.4
114.0 115.0 115.7 113.1 117.7 116.0 115.1 118.1
119.0 115.9 118.2 118.1 117.7 117.0 114.6 116.3
116.2 115.0 116.6

Set up a histogram to find the distribution of the weights. By examining the data we can determine that a reasonable offset is 110 and a reasonable cell width is 1.

Set up the histogram by pressing:

VAR # 1
 OFFSET WIDTH
 110 DATA ENTRY
 1 DATA ENTRY

V1
 OF =
 110.00 #
 C E L =
 1.00 #



To enter the data values, press:

113.3 DATA ENTRY 112.1 DATA ENTRY 115.6 DATA ENTRY
 114.1 DATA ENTRY 117.2 DATA ENTRY 116.1 DATA ENTRY
 117.1 DATA ENTRY 116.4 DATA ENTRY 114.0 DATA ENTRY
 115.0 DATA ENTRY 115.7 DATA ENTRY 113.1 DATA ENTRY
 117.7 DATA ENTRY 116.0 DATA ENTRY 115.1 DATA ENTRY
 118.1 DATA ENTRY 119.0 DATA ENTRY 115.9 DATA ENTRY
 118.2 DATA ENTRY 118.1 DATA ENTRY 117.7 DATA ENTRY
 117.0 DATA ENTRY 114.6 DATA ENTRY 116.3 DATA ENTRY
 116.2 DATA ENTRY 115.0 DATA ENTRY 116.6 DATA ENTRY

113.30 #
 112.10 #
 115.60 #
 114.10 #
 117.20 #
 116.10 #
 117.10 #
 116.40 #
 114.00 #
 115.00 #
 115.70 #
 113.10 #
 117.70 #
 116.00 #
 115.10 #
 118.10 #
 119.00 #
 115.90 #
 118.20 #
 118.10 #
 117.70 #
 117.00 #
 114.60 #
 116.30 #
 116.20 #
 115.00 #
 116.60 #

Notes

Curve Fitting-Linear & Parabolic

To set up a curve fit first press   . This sequence erases the machine of previous data and prepares it for the entry of x and y values.



If you have a plotter connected, set up the axes now as described in Chapter 8, Plotting Curve Fits and Data Points. Data points will then be plotted as they are entered.

Data points are entered in pairs, that is, $x_1, y_1; x_2, y_2;$ etc. Press **DATA ENTRY** after each x or y value has been keyed in. Entries are automatically printed and the number of entries is shown in the optional display.



To correct mistakes or to delete a data pair at some later time: press **DELETE**, key in the x value of the unwanted point, press **DATA ENTRY**, key in the y value and press **DATA ENTRY** again.

Data can be added or deleted at any time. The statistical summations of the data are preserved regardless of the number of calculations.



By pressing **LINEAR** you can calculate the coefficients of the equation $y = A + Bx^*$ and the coefficient of determination (r^2).



By pressing **PARA** you can calculate the coefficients of the equation $y = A + Bx + Cx^2^*$ and the coefficient of determination (r^2).

The coefficient of determination is a value between 0 and 1. At $r^2 = 0$, you have the worst fit. At $r^2 = 1$, you have a perfect fit.

*The equations used to calculate the coefficients are in Appendix D.

Example

A quality control engineer notes that there seems to be a relationship between the amount of chemical added to a batch, and the final concentration of the chemical in the final product. The following data represents the weight in grams added (x) and the weight in the final product (y).

x	y
2	3
1	1
6	5
3	5
7	7
6	8
9	8.5

Set up the curve fit by pressing: **VAR** **2** **V2** **.....**

If you have a plotter, set up the axes now, as described in Chapter 8.

Next, enter the data.

Press: 2	DATA ENTRY	3	DATA ENTRY	2.00	#
				3.00	#
1	DATA ENTRY	1	DATA ENTRY	1.00	#
				1.00	#
6	DATA ENTRY	5	DATA ENTRY	6.00	#
				5.00	#
3	DATA ENTRY	5	DATA ENTRY	3.00	#
				5.00	#
7	DATA ENTRY	7	DATA ENTRY	7.00	#
				7.00	#
6	DATA ENTRY	8	DATA ENTRY	6.00	#
				8.00	#
9	DATA ENTRY	8.5	DATA ENTRY	9.00	#
				8.50	#

Calculate the linear coefficients (you could start with the parabolic model if you wanted) by pressing:



```

A =
1.22 #
B =
.85 #
r² =
.83 #
    
```

The linear equation is $y = 1.22 + .85x$. Since $r^2 = .83$, you can assume you have a relatively good fit.

Y EVAL - **Linear Estimate**

Calculate a predicted y by keying in an x value and pressing **Y EVAL**. A printout of the linear estimate (LE) for $x = 5$ is shown:

Press: 5 **Y EVAL**

```

LE
5.00 #
5.48 #
    
```



If you have a plotter connected you can plot the linear curve fit by first setting up the axes and then pressing **PLOT**. A plot of this curve fit can be found on page 39.

If you are dissatisfied with the linear curve fit, calculate the parabolic curve fit.

Press: 

	A	=
	.05	#
	B	=
	1.55	#
-	C	=
	.07	#
r ²		=
	.86	#

The parabolic equation is $y = .05 + 1.55x - .07x^2$. As you can see from the printout above, the coefficient of determination (r^2) is a little closer to 1; the fit is a little better.

 - **Parabolic Estimate**

By keying in an x value and pressing  EVAL you can calculate a parabolic estimate (PE) this time:

Press: 5 

PE		
	5.00	#
	6.00	#

 EVAL calculates a predicted y based on the previous curve fit.



If you have a plotter connected you can plot the parabolic curve fit using the axes already set up for the linear model. Simply press **PLOT**. A plot of the parabolic model is found on page 39.



You can also calculate the sample size, mean of x, standard deviation of x, mean of y, standard deviation of y, and simple correlation coefficient by pressing **BASIC STAT**.

Press:



N	7.00	= #
\bar{x}	4.86	= #
$\Delta 1$	2.91	= #
\bar{y}	5.36	= #
$\Delta 2$	2.72	= #
R	.91	= #

NOTE

To use \hat{Y} EVAL or PLOT after pressing BASIC STAT, you must press PARA or LINEAR again since the coefficients of the curve fits are stored in the same locations as the BASIC STAT calculations.

Data Storage Locations

During calculations, summations and other information are stored in 17 storage locations numbered 0 through 16. The following table shows what information is stored in which location.

Location	Contents	Location	Contents
0	No. of entries	9	No. of entries
1	Σx	10	} See Expansion Below
2	Σx^2	11	
3	Σxy	12	
4	Σy	13	
5	Σy^2	14	
6	Σx^3	15	---
7	Σx^4	16	---
8	$\Sigma x^2 y$		

Location	After These Operations				
	Data Entry	Basic Stat	Linear	\hat{Y} Eval	PARA
10	---	\bar{y}	A	---	A
11	---	Δy	B	---	B
12	---	R	---	---	C
13	x value	\bar{x}	r^2	x value	r^2
14	y value	Δx	---	\hat{Y} value	---

To recall the contents of any of these locations:

1. Key in the location number
2. Press 

This information can be used to calculate additional statistical functions using keys on the right side of the machine which are described in Chapter 9.

Press **VAR R** **0** to set up a two-sample t calculation. This sequence erases the machine of previous data and prepares it for the entry of two sets of data.

DATA ENTRY

Enter the first set of data values by keying in each entry and pressing **DATA ENTRY**. Each entry is automatically printed. The number of entries appears in the optional display.

To enter the second set of data, press **CHANGE/SAMPLE**, key in each data value and follow it with **DATA ENTRY**.

DELETE

If you find that you have made a mistake, or if you want to delete a data value at some later time, first determine whether the value is in data set one or two. If it is in the same data set you are currently in, press **DELETE**, key in the unwanted value and press **DATA ENTRY**. If it is in the other data set, press: **CHANGE/SAMPLE**, **DELETE**, the unwanted value, and finally **DATA ENTRY**.

Data can be added or deleted at any time. The statistical summations of the data are preserved regardless of the number of calculations.

t

By pressing **t** you calculate the two-sample t value and the number of degrees of freedom. Both values are printed. A t table is located in Appendix D of this manual for easy reference.

Example

Eagleton Mining Tools of Waynesburg, Pa. has two classes of salesmen: 1) senior salesmen who operate on straight commission and 2) junior salesmen who operate on a base salary. Is there a difference between the average sales of each group? The following data was compiled.

	Senior	Junior
Average	10.1	7.7
Sales	8.7	9.1
Over	6.2	10.8
The	11.8	5.2
Last	9.3	7.9
Six	12.1	6.5
Months	6.9	
	7.5	

We'll set up the problem to test the hypothesis that there is no difference in sales, that is, $H_0: \bar{x} = \bar{y}$:

If $|t_{\text{calc.}}| \leq t_{\text{table}}$, we accept the hypothesis

If $|t_{\text{calc.}}| > t_{\text{table}}$, we reject the hypothesis

First press: 2 T

Next, enter the data from the first sample.

Press: 10.1 8.7

6.2 11.8

9.3 12.1

6.9 7.5

DATA 1
10.10 #
8.70 #
6.20 #
11.80 #
9.30 #
12.10 #
6.90 #
7.50 #

Now enter the data from the second sample.

Press:  DATA 2

7.7		9.1		10.8		7.70	#
						9.10	#
						10.80	#
5.2		7.9		6.5		5.20	#
						7.90	#
						6.50	#

Calculate t and the number of degrees of freedom by pressing:

 T =

1.07 #

 D =

12.00 #

If we assume a confidence level of 95% we find that at 12 degrees of freedom $t_{table} = 2.18$.

$$|1.07| \leq 2.18$$

$$t_{calc.} \leq t_{table}$$

Since the absolute value of $t_{calc.}$ is less than t_{table} we accept the hypothesis. The average sales for each group were about the same.

If you need additional information about the two classes of salesmen, pressing **BASIC STAT** will print the following information:

```

sample size of the first data set      N1      =
                                         8.00    #
mean of the first data set             $\bar{x}$       =
                                         9.08    #
standard deviation of the first data set  $\Delta 1$  =
                                         2.18    #

sample size of the second data set     N2      =
                                         6.00    #
mean of the second data set            $\bar{y}$       =
                                         7.87    #
standard deviation of the second data set  $\Delta 2$  =
                                         1.96    #

```

Data Storage Locations

During calculations, summations and other information are stored in 17 storage locations numbered 0 through 16. The table below shows what information is stored in which data location.

Location	Contents	Location	Contents
0	No. of entries in 1st sample	9	No. of entries in 2nd sample
1	Σx	10	\bar{y}
2	Σx^2	11	Δy
3	---	12	---
4	Σy	13	\bar{x}
5	Σy^2	14	Δx
6	---	15	t value
7	---	16	degrees of freedom
8	---		

To recall the contents of any of these locations:

1. Key in the location number
2. Press 

This information can be used to calculate additional statistical functions using the keys on the right side of the machine which are described in Chapter 9.

Notes

Press $\text{VAR} \#$ 2 to set up a paired t calculation. This sequence erases the calculator of previous data and prepares it for the entry of x and y values.



Data points are entered in pairs, that is $x_1, y_1; x_2, y_2;$ etc. After each x or y value has been keyed in, press **DATA ENTRY**. Each entry is automatically printed and the number of entries is shown in the optional display after each operation.



To correct mistakes or delete a data pair; press **DELETE**, key in the x value of the unwanted point, press **DATA ENTRY**, key in the y value, and finally press **DATA ENTRY** again.

Data can be added or deleted at any time. The statistical summations of the data are retained regardless of the number of calculations.



By pressing t you can calculate the paired t value and the number of degrees of freedom. Both values are printed. A t table is located in Appendix D for your convenience.

Example

In a test to determine the effectiveness of hypnotic treatments in reducing or eliminating sleep walking, the following data was collected from patients before and after treatment.

Patient	Incidents Per Month	
	Before	After
1	6	2
2	4	3
3	7	5
4	4	4
5	3	3
6	2	2
7	6	1
8	5	2
9	4	2
10	6	3

Set up a null hypothesis: $H_0 \bar{x} = \bar{y}$ (the treatment had no effect on the patients).

If $|t_{\text{calc.}}| \leq t_{\text{table}}$ - accept the hypothesis

If $|t_{\text{calc.}}| > t_{\text{table}}$ - reject the hypothesis

Assume a confidence level of 95%.

Set the problem up by pressing: VAR^* 2 V2 \dots

Next enter the data by pressing:

6 2

4 3

7 5

4 4

3 3

2 2

6 1

5 2

4 2

6 3

6.00 #

2.00 #

4.00 #

3.00 #

7.00 #

5.00 #

4.00 #

4.00 #

3.00 #

3.00 #

2.00 #

2.00 #

6.00 #

1.00 #

5.00 #

2.00 #

4.00 #

2.00 #

6.00 #

3.00 #

Calculate the t paired value and the number of degrees of freedom by pressing:

TP =

3.59 #

D =

9.00 #

At 9 degrees of freedom and a confidence level of 95% $t_{table} = 2.26$.

$$|3.59| > 2.26$$

$$|t_{calc.}| > t_{table}$$

Therefore we reject the hypothesis. Hypnotism was indeed effective in reducing sleep walking.



To obtain further information about the data press **BASIC STAT**. The sample size, means, standard deviations, and simple correlation coefficient, are calculated and printed:

```

N          =
10.00     #
x̄          =
4.70     #
s1        =
1.57     #
ȳ         =
2.70     #
s2        =
1.16     #
R         =
.19     #

```

Data Storage Locations

During t paired calculations, summations and other information are stored in 17 storage locations numbered 0 through 16. The table following shows what information is stored in which data location.

Location	Contents	Location	Contents
0	No. of entries	9	No. of entries
1	Σx	10	\bar{y}
2	Σx^2	11	Δy
3	Σxy	12	R
4	Σy	13	} See Expansion Below
5	Σy^2	14	
6	Σx^3	15	
7	Σx^4	16	
8	$\Sigma x^2 y$		t paired degrees of freedom

Location	After These Operations	
	Data Entry	Basic Stat
13	x value	\bar{x}
14	y value	Δx

To recall the contents of any of these locations:

1. Key in the location number
2. Press 



This information can be used to calculate additional statistical functions using the keys on the right side of the calculator which are described in Chapter 9.

Notes

Chapter 7 Plotting the Histogram

Histograms are easily plotted once the range of axes, tic marks, and axes intercepts have been defined. First connect the plotter to the calculator and set the lower left and upper right plotting limits as described in the 9862A Plotter Peripheral Manual.

X Axis Range

The range of the X axis determines the number of cells plotted. Normally you want to plot all 10 cells. This is done by keying in 0 and pressing **STORE** then keying in 10 and pressing **AXES** **1** .

Y Axis Range

The range of the Y axis represents the range of cell frequencies. Key in 0 and press **STORE**. Then key in a number that is one or two greater than the greatest cell frequency (remember cell frequencies are printed for each cell in the histogram), and press **AXES** **2** .

Tic Mark Intervals

To divide the X and Y axes into segments with tic marks, specify the tic mark intervals for both axes. For the X axis you probably want to have a tic mark at each cell boundary. To do this, key in 1 and press **STORE**. For the Y axis key in the tic interval which shows the range of cell frequencies. Finally press **AXES** **3** . To specify no tic marks for an axis, use 0 for the tic interval.

Axes Intercept Coordinates

The axes intercept coordinates specify at what point the X and Y axes will cross. This is usually 0,0. Key in the x value for the intercept point and press **STORE**.

Remember that x is a cell value, not an actual number on the axis. If, for example, you key in 5 for x, the y axis will be drawn crossing the x axis at the upper boundary of cell 5, whether the cell width is 1 or 10.

Key in the y intercept value and then press **AXES** **4** .

The plotter will plot both the axes and the tic marks at this time. Any value not specified will remain as it was in the previous problem. To specify exactly the same axes as the previous problem press **AXES 0** .

The axes and tic marks are not plotted using this sequence unless you specify again the tic interval and axes intercepts, but you can plot the histogram by itself.

PLOT

With the axes defined, press **PLOT** and the histogram is plotted.

Example

To plot the histogram calculated in Chapter 3, first set up the axes. From the histogram information printed, we can determine the following values:

- x values --- 0 and 10 (this plots all 10 cells)
- y values --- 0 and 7 (one greater than the greatest frequency)
- tic intervals --- x = 1
y = 1
- axes intercepts --- x = 0
y = 0

To set up this plot press:

X axis values (Range 1)	<div style="display: flex; align-items: center; margin-bottom: 5px;"> <div style="border: 1px solid black; border-radius: 5px; padding: 2px 10px; margin-right: 5px;">0</div> <div style="border: 1px solid black; border-radius: 5px; padding: 2px 5px; margin-right: 5px;">STORE</div> </div> <div style="display: flex; align-items: center;"> <div style="margin-right: 5px;">10</div> <div style="border: 1px solid black; border-radius: 5px; padding: 2px 5px; margin-right: 5px;">AXES</div> <div style="border: 1px solid black; border-radius: 5px; padding: 2px 10px;">1</div> </div>	<pre> .00 → RG1 = .00 # 10.00 # </pre>
Y axis values (Range 2)	<div style="display: flex; align-items: center; margin-bottom: 5px;"> <div style="border: 1px solid black; border-radius: 5px; padding: 2px 10px; margin-right: 5px;">0</div> <div style="border: 1px solid black; border-radius: 5px; padding: 2px 5px; margin-right: 5px;">STORE</div> </div> <div style="display: flex; align-items: center;"> <div style="margin-right: 5px;">7</div> <div style="border: 1px solid black; border-radius: 5px; padding: 2px 5px; margin-right: 5px;">AXES</div> <div style="border: 1px solid black; border-radius: 5px; padding: 2px 10px;">2</div> </div>	<pre> .00 → RG2 = .00 # 7.00 # </pre>
tic intervals	<div style="display: flex; align-items: center; margin-bottom: 5px;"> <div style="margin-right: 5px;">1</div> <div style="border: 1px solid black; border-radius: 5px; padding: 2px 5px; margin-right: 5px;">STORE</div> </div> <div style="display: flex; align-items: center;"> <div style="margin-right: 5px;">1</div> <div style="border: 1px solid black; border-radius: 5px; padding: 2px 5px; margin-right: 5px;">AXES</div> <div style="border: 1px solid black; border-radius: 5px; padding: 2px 10px;">3</div> </div>	<pre> 1.00 → T I = 1.00 # 1.00 # </pre>

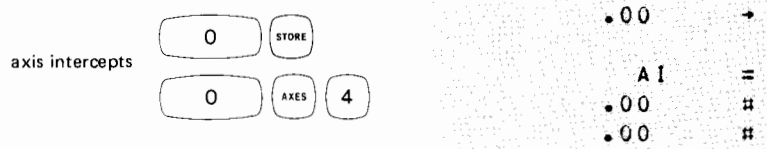

Now press **PLOT**. The graph below was generated with this axes set up.

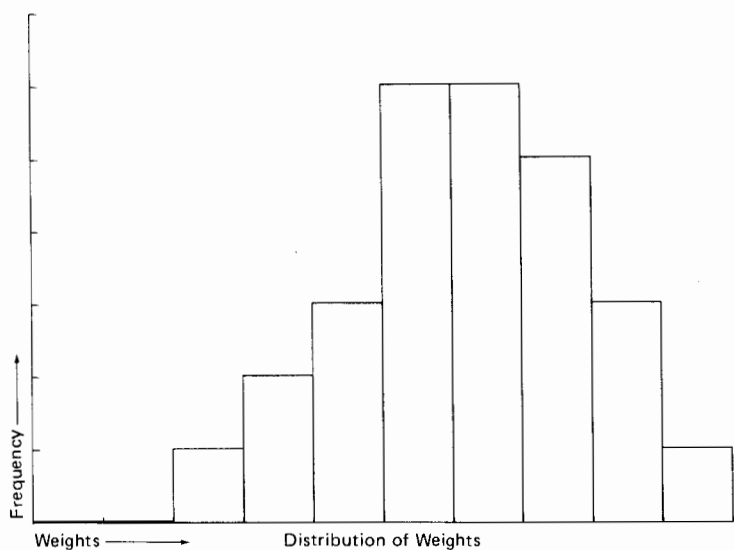

To plot portions of the histogram the procedure is similar. Define the X axis range in the following manner. Key in the number of cells you want to suppress at the beginning of the histogram and press **STORE**. Then key in the number of the last cell you want to plot and press **AXES** **1**. For example, suppose you wanted to plot cells 4 through 9. First key in 3, representing the three cells you didn't want to have plotted. Then press **STORE** and key in 9, specifying that the ninth cell is the last to be plotted. Finally press **AXES** **1**. The Y axis range, tic marks, and axes intercepts are defined as before.

When you have specified only a portion of the histogram to be plotted, the plotter will still go through the motions of plotting the suppressed cells at the beginning of the histogram. However, only the cells specified are actually plotted.

Notes

Plotting Curve Fits and Data Points

Once the range of the axes, tic marks, and axes intercept have been defined, you can easily plot parabolic and linear curve fits as well as individual data points.

X Axis Range

The range of the X axis is determined from the data. Decide upon minimum and maximum values for x such that all the x values will fall within that range. Then key in the minimum value, press **STORE**, key in the maximum value and press **AXES** **1** . When the calculator is first switched on, the X axis range is from 0 to 1.

Y Axis Range

The Y axis is set up in the same way as the X axis. Decide upon the minimum and maximum values for y first. Key in the minimum value, press **STORE**, key in the maximum value, and press **AXES** **2** . At turn-on, this range is also from 0 to 1.

Tic Mark Intervals

To divide the X and Y axes into segments with tic marks, specify the tic mark intervals for both axes. Use a tic interval which will best show the range of the data. For example, if your data falls between 0 and 100, you probably want to have a tic interval of 10 or 20 rather than 1. Key in the x tic interval, press **STORE**, key in the y tic interval, and finally press **AXES** **3** . To specify no tic marks for an axis, use 0 for the tic interval.

Axes Intercept Coordinates

The axes intercept coordinates specify at what point the X and Y axes will cross. Key in the x value for the intercept point and press **STORE**. Then key in the y value and press **AXES** **4** .

The plotter will now plot both the axes and the tic marks. Any value not specified will remain as it was in the previous problem. To specify exactly the same axes as the previous problem, simply press **AXES 0**.

The axes and tic marks are not plotted using this sequence unless you again specify the tic interval and axes intercept.

Individual Data Points

With the axes defined, you can plot data points as they are entered. Normally the plotter draws an \times at each point plotted. However, you have the option of specifying four other characters and whether you want the points connected by straight lines or unconnected (see table below).

DIGIT CODE		
Unconnected	Connected	Character
0	5	x
1	6	+
2	7	◇
3	8	□
4	9	X (delete)

To specify the character, press  and follow it with a number between 0 and 9. If part of a character falls outside the plotting limits, the character will be distorted. To avoid this it is a good idea to set up the graph limits so that they extend beyond the smallest and largest data points by at least 1% of the graph range.

When data points are deleted, a large X is plotted over the previous character. This character can also be specified, if needed, by selecting either character code 4 or 9.

Curve Fits

After data has been entered and either the linear or parabolic coefficients have been calculated, you can plot the curve fit by pressing PLOT.

Example A: Plotting Curves

To plot the curve fits calculated in Chapter 4, first set up the axes. By examining the data, the following values can be determined:

X range --- 0 thru 10

Y range --- 0 thru 10

tic intervals:

X = 1

Y = 1

axes intercept:

X = 0

Y = 0

The axes should be set up before the data is entered so that the individual points can also be plotted.

Press: VAR 2	V2	
		.00	→
0 STORE 10 AXES 1		RG1	=
		.00	#
		10.00	#
0 STORE 10 AXES 2		.00	→
		RG2	=
		.00	#
		10.00	#
1 STORE 1 AXES 3		1.00	→
		T I	=
		1.00	#
		1.00	#
0 STORE 0 AXES 4		.00	→
		AI	=
		.00	#
		.00	#

As you can see, the axes and tic marks are plotted after pressing AXES

4. The data points are plotted as they are entered:



Calculate the linear coefficients by pressing:

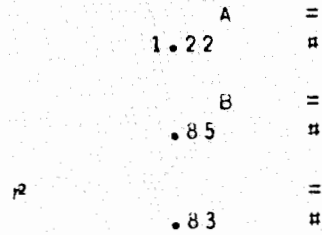

Plot the linear curve fit by pressing:



Calculate the parabolic coefficients by pressing:

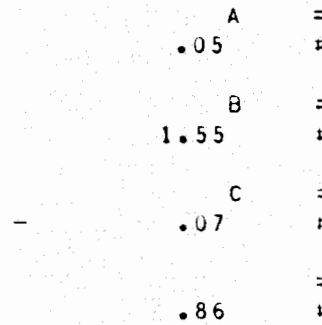

Plot the parabolic curve fit by pressing:



The final graph should duplicate the one shown on the next page.

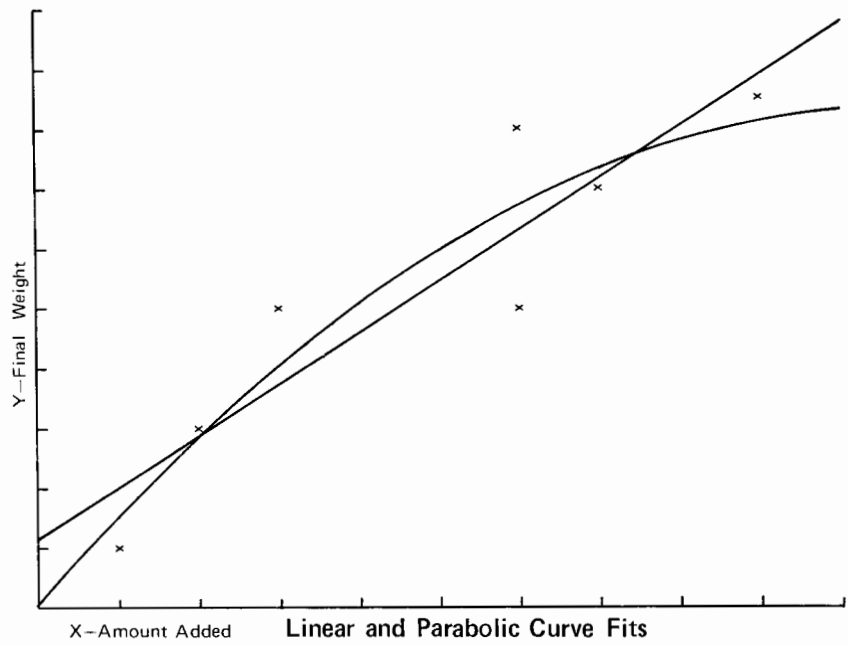

Example B: Plotting Data

A high school counselor would like to determine what effect mathematics studies have on future student success in various university studies. In particular, does the number of years of math relate to university physics, chemistry, and German? Data was collected for 100 students who received his counseling prior to university study. All 100 students were required to enroll in physics, chemistry, and German. The data table below lists the average grades for each group:

Group (yrs. of math)	German	Chemistry	Physics
1	90	65	60
2	85	70	65
3	80	78	85
4	70	85	92

To set up the calculator for data plotting press:

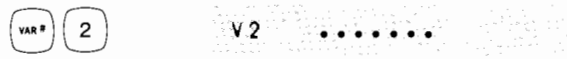

In order to plot the data points first define the range of the axes, the tic intervals, and the axes intercept. From the data we can determine that:

X range --- 0 thru 5

Y range --- 50 thru 100

tic intervals:

X = 1

Y = 10

axes intercept:

X = 50

Y = 4

Set up the axes by pressing:

0 **STORE** 5 **AXES** 1

50 **STORE** 100 **AXES** 2

1 **STORE** 10 **AXES** 3

0 **STORE** 50 **AXES** 4

```

      .00      →
      RG1     =
      .00     #
      5.00    #
      50.00   →
      RG2     =
      50.00   #
      100.00  #
      1.00    →
      T I     =
      1.00   #
      10.00  #
      .00     →
      A I     =
      .00    #
      50.00  #
  
```

The axes and tic marks are plotted after **AXES 4** has been pressed. Individual data points can now be plotted as they are entered.





The first plot is for German grades. For this plot we'll use the connected character , character #5.



Press:  5

CT5

Next enter the data:



Press: 1		90		1.00	#
				90.00	#
2		85		2.00	#
				85.00	#
3		80		3.00	#
				80.00	#
4		70		4.00	#
				70.00	#

The chemistry plot is done in a similar manner. First press  2. Next specify the same axes set-up as before by pressing  0. Pick a different character for this plot. We used character #7. Now enter the data.

The physics plot is done exactly the same way as the chemistry plot. We used character #8.

The three plots are shown on the following page. They show that:

1. Mathematics is very useful to university physics; the more the better.
2. Mathematics is also very useful to university chemistry; but less than for physics.
3. Mathematics seems to have a negative effect on university German.

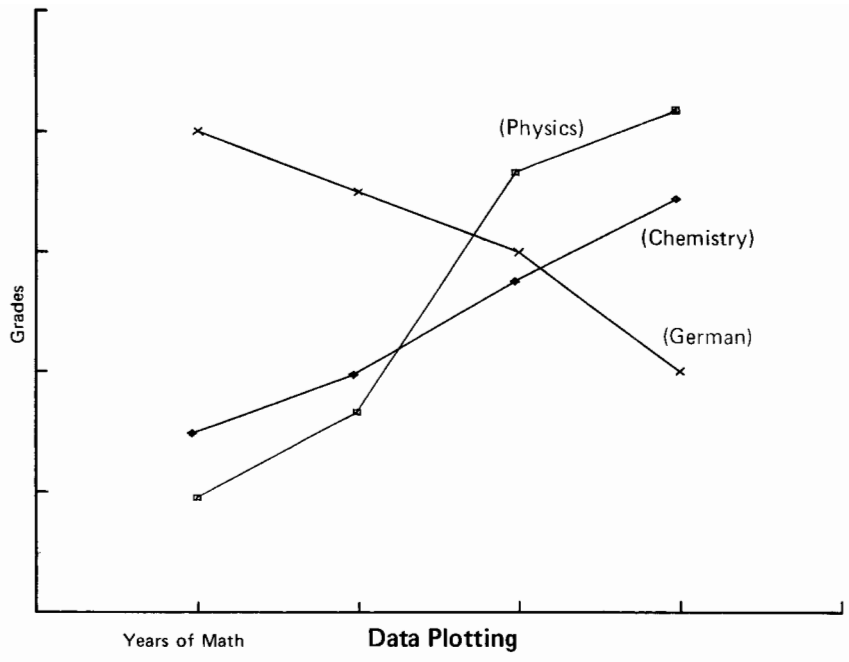

Additional Math Functions

This chapter describes the additional functions and features of the calculator which you can use to derive other statistical equations or simply to do your income tax.

Rounding

When the calculator is switched on, the printing format (and the display format, if your calculator has a display) is set to 'Round 2'. That means that the calculator rounds each number printed to the nearest hundredth. The printing format can be set to any rounding value between 0 and 6 by pressing **RND** () followed by the appropriate numerical key. The calculator can also be set to print in 'scientific notation' by pressing **RND** () **.**.

Whenever a number is too large for the current printing format, the number is automatically printed (and displayed) in scientific form.

NOTE

The printing format does not affect calculating accuracy, since the calculator performs all calculations to ten digits.

Here are the possible printing formats for the number 12.3456789:

1.234567890 01 #	Scientific notation
12.345679 #	} 'Round 6' through 'Round 0'
12.34568 #	
12.3457 #	
12.346 #	
12.35 #	
12.3 #	
12. #	

What's Scientific Notation ?

Scientific notation is merely a shorthand way of expressing very large or very small numbers. In scientific form a number is expressed with a mantissa and an exponent. For example:

$$93,000,000 \text{ (93 million)} = 9.3 \times 10^7$$

$9.3000000000 \quad 07 \text{ :#}$

↑ ↑ ↑ ↑
mantissa exponent mantissa exponent

Accumulating Results

The Model 5 has an automatic accumulator feature which you can use whenever you wish – here's how it works:

Each time you press $\boxed{=}$ the resulting number (R) is also added to the number in the accumulator. Before using the accumulator, press $\boxed{\text{CLEAR}}$ to erase it. Later, when you wish to recall and print the current accumulated number, press $\boxed{\text{SHIFT}} \boxed{=}$; the letters 'RT' (result total) are printed with the number.

Example

Multiply each number in the list below by the constant .25 and then find the sum of the products.

27
35
72
53
61

To erase the accumulator, press $\boxed{\text{CLEAR}}$

To store the constant multiplier, press $\boxed{\cdot} \boxed{2} \boxed{5} \boxed{\text{STORE}}$

Now press:

27

35

72

53

61

CLEAR

.25 →
27.00 x
.25 +
.25 =
6.75 R
35.00 x
.25 +
.25 =
8.75 R
72.00 x
.25 +
.25 =
18.00 R
53.00 x
.25 +
.25 =
13.25 R
61.00 x
.25 +
.25 =
15.25 R
62.00 RT

To recall and print the sum,
press

Using Parentheses

As you saw in some of the previous examples, the Model 5 calculates each new operation by using the result of the previous one. By using the keys, you can group operations together in the same way as when parentheses are used in math notation. For example, solve:

$$9 \div (35 - 8) = ?$$

Here's one way to solve the problem without using the PARENS keys (constant storage is used to store an intermediate result):

$$\begin{aligned} 35 - 8 &= C \text{ (constant storage)} \\ 9 \div C &= ? \end{aligned}$$

Press these keys:

$$35 \text{ [-] } 8 \text{ [=]}$$

[STORE]

$$9 \text{ [÷] } \text{[RECALL]} \text{ [=]}$$

```

35.00  -
 8.00  =
27.00  R
27.00  +
 9.00  +
27.00  =
27.00  =
.33    R
    
```

Now, by using [(] [)], you can key in the problem just as it was originally written by pressing:

$$9 \text{ [÷] } \text{[(] } 35 \text{ [-] } 8 \text{ [)]} \text{ [=]}$$

```

 9.00  ÷
35.00  (
 8.00  -
27.00  )
.33    =
      R
    
```

Notice that the calculator prints the result of the operation within parentheses when [)] is pressed.

Using parentheses not only makes the problem easier to key in, but it can eliminate the need for storing and recalling intermediate results.

By using [(] [)], expressions like $(35 - 8)$ can be grouped within other expressions five levels deep (this is called 'nesting' expressions). For example:

$$9 \times (6+4) \text{ divided by } 5 \times (7-4) = ?$$

We cannot key in the problem just as it appears, since the calculator would first divide the result of $9 \times (6+4)$ by 5 and *then* multiply that product by $(7-4)$. But since parentheses can be nested, the complete denominator can be enclosed within parentheses as the problem is keyed in. Here's the problem to key in:

$$9 \times (6+4) \div (5 \times (7-4)) = ?$$

To solve the problem, press:

9 (6 + 4) ÷	9.00 ×
	(
	6.00 +
	4.00)
	10.00 +
	(
	5.00 ×
	(
(5 (7 - 4))	7.00 -
	4.00)
	3.00)
=	15.00 =
	6.00 R

Also, notice that \times keys were not used since the calculator automatically assumes multiplication when $($ follows a number entry.

Numbers To Powers

\uparrow is used to raise the current result, or a number just keyed in, to a power. The power is indicated by the second number keyed in.

Examples

- a. Cube 25 (that's $25 \times 25 \times 25$)

Press: 25 \uparrow 3 =

25.00	↑
3.00	=
15625.00	R

- b. Find 10^6 (that's $10 \times 10 \times 10 \times 10 \times 10 \times 10$)

Press: 10 \uparrow 6 =

10.00	↑
6.00	=
1000000.00	R

- c. Now, find 10^{33} (that's a decillion).

Press: 10 \uparrow 33 =

10.00	↑
33.00	=
1.000000001	33 T

The last printout shows an example of rounding error. Since the operation includes an internal routine using logarithms, results are not always accurate to the last decimal place – in this case the magnitude of error is only one billionth!

- d. Find the area of a circle that has a radius of 8 feet.

Problem: Area = πr^2
where: $r = 8$ feet
 $\pi = 3.14 \dots$

Press: 3.14 (8 \uparrow 2) =

3.14	×
8.00	↑
2.00)
64.00	=
area in sq. ft. → 200.96	R

Percentage Calculations

The **%** key can be used either to find a percentage of the number just keyed in, or to use a percentage of a number within a problem.

Examples

- a. Find 6% of 39.95.

Press: **CLEAR** 39.95 **x** 6 **%** **=**

	CLEAR	
39.95	x	
6.00	%	
.06	=	
2.40	R	

- b. Find the cost of an \$8.00 item after it's discounted 15%.

Press: 8 **-** 15 **%** **=**

8.00	-	
15.00	%	
1.20	=	
6.80	R	

- c. Find the simple interest on a loan for \$500.00 that's payable in two years at a 7% interest rate.

Problem: $I = PRT = 500 \times 7\% \times 2 = ?$

Press: 500 **x** 7 **%** **x** 2 **=**

500.00	x	
7.00	%	
.07	x	
2.00	=	
70.00	R	

- d. Now, find the total cost of these items after discounting them:

- a. 7 - \$3.00 items (15% discount)
- b. 2 - \$6.50 items (15% discount)
- c. 5 - \$32.00 items (25% discount)

Since this problem requires that the 'sum of the products' be found, the accumulator feature can be used to 'sum-total' the separate products (discounted costs).

First, press **CLEAR** to erase the accumulator. Then press:

$$7 \times 3 - 15 \% =$$

	CLEAR	
7.00	x	
3.00	-	
15.00	%	
3.15	=	
17.85	R	

$$2 \times 6.5 - 15 \% =$$

2.00	x	
6.50	-	
15.00	%	
1.95	=	
11.05	R	

$$5 \times 32 - 25 \% =$$

5.00	x	
32.00	-	
25.00	%	
40.00	=	
120.00	R	

Now, to recall the total discounted cost, press:

$$\text{SHIFT} = 148.90 \text{ RT}$$

Special Functions

Your Model 5 has five special functions which are printed in green on the front-side of some keys. You can perform each of the special functions by first pressing **SHIFT** and then the function key. You need not press **=** when using these functions since the result is calculated (but not accumulated) immediately after you press the function key.

Divide By 12

Press SHIFT $\frac{\square}{12}$ to divide the number just keyed in or the current result by 12.

Reciprocal Value

Pressing SHIFT $\frac{1}{x}$ calculates the reciprocal value of the number keyed in or the current result.

Examples

- a. Find the cube root of 29791. Since $\sqrt[3]{29791}$ can also be expressed as $29791^{1/3}$, press:

29791 \uparrow 3 SHIFT $\frac{1}{x}$ = 29791.00 \uparrow
3.00 $\frac{1}{x}$
.33 =
31.00 R



- b. Find the monthly payment on a 2 year, \$3000 installment loan with an 11.5% annual interest rate.

$$\begin{aligned} \text{Monthly Payment} &= \frac{\text{Principal X Monthly Interest Rate}}{1 - \left[\left(\frac{1}{1 + \text{Monthly Interest Rate}} \right)^{\text{no. of payments}} \right]} \\ &= \frac{3000 (11.5/12)}{1 - \left(\frac{1}{1 + 11.5\%/12} \right)^{24}} \end{aligned}$$

Press:

	3000.00	x
3000 () 11.5 % $\overline{\text{SHIFT}}$ -) STORE	11.50	%
	.12	$\overline{\text{R}}$
	.01)
	.01	→
	.01	+
	1.00	(
	1.00	-
	.01	(
	.01	(
	.01	+
	.01	→
	.01)
	1.01	%
	.99	↑
	24.00)
	.80)
	.20	=
	140.52	R

3000 () 11.5 % $\overline{\text{SHIFT}}$ -) STORE	$\times/12$
---	-------------

$\overline{\text{DIV}}$ () 1 - () () 1 + $\overline{\text{RECALL}}$)
--

$\overline{\text{SHIFT}}$ $\overline{\text{UP}}$ $\overline{\text{UP}}$ 24)) =	$\overline{\text{DIV}}$
--	-------------------------

monthly payment →

Logarithms

The Model 5 has internal routines for calculating common logarithms, natural logarithms, and antilog_e (e=2.71828...).

To find the common log (log₁₀) value, press $\overline{\text{SHIFT}}$ $\overline{\text{DIV}}$

To find the natural log (ln) value, press $\overline{\text{SHIFT}}$ $\overline{\text{X}}$

To find the antilog_e (e^x) press $\overline{\text{SHIFT}}$ $\overline{\text{+}}$

To find the antilog₁₀ (10^x), press 10 $\overline{\text{UP}}$, enter the 'X' value, then press =

Example

Since sound level is measured on a logarithmic scale (in 'decibels' or 'db'), you could find the relative loudness of live rock music you listened to once, since you noticed that the sound level meter which monitored the music measured 123 db.

Since the formula for finding sound level is:

$$\text{db} = 10 (\log_{10} x)$$

where: x is the increase in relative sound level (number of times louder than the least audible sound)

We can solve for x by using this formula:

$$\text{relative loudness} = \text{antilog} \frac{\text{db}}{10} = \text{antilog} \frac{123}{10} = 10^{(123/10)}$$

Press:

10	(↑)	(123	(÷)	10)	10.00	↑
								(
							123.00	÷
							10.00)
							12.30	=
							1.995262307	12R

=

Your calculation is quite realistic since live rock music *is* known to be about *two-trillion* times louder than the softest sound that could be heard.

While working with the decibel scale, it's known that ordinary conversation is about one million times louder than the softest sound that can be heard. If that is true, at what decibel level would conversation register on the sound level meter?

$$\begin{aligned} \text{db} &= 10 \log_{10} x \\ &= 10 \log 10^6 \end{aligned}$$

Press:

10	(10	(↑)	6	(SHIFT)	(÷))	10.00	×
									(
								10.00	↑
								6.00	lg
								.78)
								6.00	=
								60.00	R

=

Automatic Decimal Point

When you're solving problems which include many numbers of the same form, such as dollars and cents, press **AUTO** down to automatically enter a decimal point at the same position when you key in each number. For example, add this column of figures:

$$\begin{array}{r}
 39.95 \\
 25.50 \\
 1.45 \\
 5.00 \\
 \hline
 .95 \\
 ?
 \end{array}$$

When not using the **AUTO** feature, you must enter each number and press **.** at the correct place. But, after switching **AUTO** on, you just enter each number, since the decimal point is correctly entered for you. Here's how to add the numbers when the **AUTO** feature is used ('Round 2' format should be set).

Press: **CLEAR** **AUTO** (down)

now, press: 3995 **+** 2550 **+**

145 **+** 5. **+** 95 **=**

CLEAR	
39.95	+
25.50	+
1.45	+
5.00	+
.95	=
72.85	R

By the way, notice that you can still enter a decimal point manually (see the \$5.00 entry) when **AUTO** is switched on.

Turn-On Procedure

Please read the following pages before using your Model 5 for the first time.

Accessories

Each Model 5 is furnished with these basic accessories:

<u>DESCRIPTION</u>	<u>-hp- PART NUMBER</u>
Operating Guide	09805-90002
Instruction Booklet	09805-90003
Printer Paper (2 rolls)	9281-0415
Printer Ribbon	9282-0511
Power Cord	(see below)
Dust Cover	4040-0989
Spare Fuses:	
$\frac{1}{2}$ A, 250 V, normal -blo	2110- 0004 0202
$\frac{1}{4}$ A, 250 V, normal -blo	2110- 0012 0201
Travel Case	5061-0707

Power cords with different plugs are available for the calculator. Each plug, together with the part number of the power cord which has that plug, is shown below. Each plug has a ground connector. The cord packaged with each calculator depends upon where that calculator is to be delivered. If your calculator has the wrong power cord for your area, please contact your local -hp- Sales and Service Office.

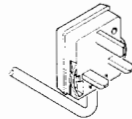

8120-1351

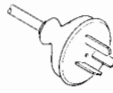

8120-1369

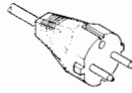

8120-1689

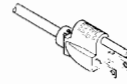

9120-1378
(Standard)

Initial Inspection

Please check to see that all the accessories listed above are present when unpacking your Model 5. Also, inspect the Model 5 for damage which may have occurred during shipment. If you find any damage, or if any accessories listed are missing, you should file a claim with the carrier and contact the nearest -hp- Sales and Service Office listed at the back of Appendix C.

Turn-On Procedure

Power Requirements

The Model 5 operates on power line voltages of either 101 to 130 volts ac or 202 to 259 volts ac, with a power line frequency from between 48 and 66 Hz. The calculator requires a maximum power of 40 voltamps.

Grounding Requirements

The Model 5 meets current NEMA (National Electrical Manufacturers' Association) grounding standards provided that a three-conductor power cord is used to supply power to the calculator from a suitably grounded outlet.

Follow these steps to switch your Model 5 on for the first time:

1. Before connecting the power cord to the back of your calculator, check the position of the voltage selector card in the power module (see the following photographs). The number visible indicates which nominal voltage range is set. If the card is set to the correct voltage range, you may skip the next step and go to step 3.

CAUTION

YOUR MODEL 5 CAN BE DAMAGED IF IT'S SWITCHED ON WHEN NOT SET FOR THE CORRECT LINE VOLTAGE.

2. To reset the voltage selector card:

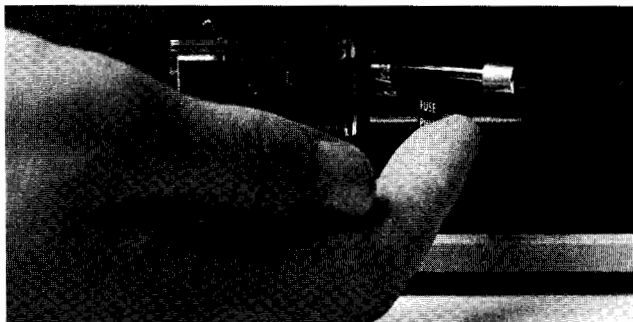

- a. Slide the plastic window to the left and move the FUSE PULL lever to the left (removing the fuse).

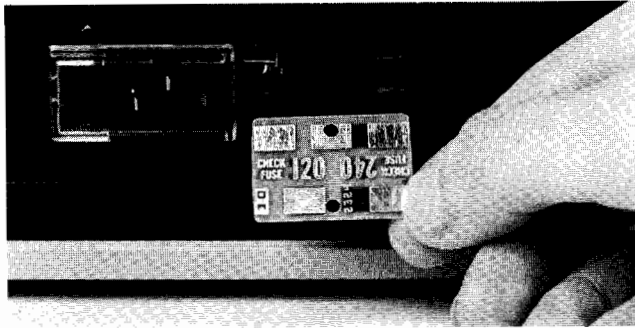

- b. Position the line voltage selector such that the number indicating the required voltage setting is on the left.

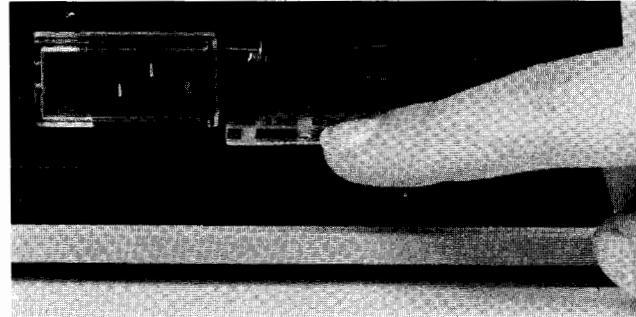

- c. Push the line voltage selector into the power module, insert the proper fuse, and slide the plastic window to the right.

NOTE

For 120V ac operation, use a $\frac{1}{2}$ A. fuse. For 240V ac operation, use a $\frac{1}{4}$ A. fuse.

3. Plug the power cord into the back of the calculator and into a suitable wall outlet.
4. Turn your calculator on by pressing the LINE switch down. Each time the Model 5 is switched on, the word 'CLEAR' is printed, the busy light should flash on for a moment, and the display (if installed) should appear like this:



Your Model 5 is now ready to use. To switch the calculator off, merely press the LINE switch again so that 'OFF' is visible.

If your calculator does not operate as described in Step 4, see 'CALCULATOR SERVICE', Appendix C.

Accuracy

Basic arithmetic operations $+$, $-$, \times , \div , $\%$ are accurate to

10 places, with a possible error of one count in the tenth (least – significant) digit.

Special functions ($1/x$, $x/12$, \lg , \ln , e^x) and exponentiation (\uparrow) operations are accurate to not less than 8 places – the accuracy is due to rounding error and depends upon the individual problem.

Calculating Range

Any number entry or calculation resulting in a number equal to or greater than 10^{100} causes 9.99999999 99 to be printed (and displayed). Number entries or calculations having a result less than 10^{-99} are printed (and displayed) as zero.

Operating Errors

Improper number entries, key sequences and calculations are indicated by printed 'NOTES' – a list of notes is in Appendix D. Some improper calculations are:

- dividing by 0
- finding the log or \ln of 0
- raising 0 to a negative power
- finding the log or \ln of a negative number
- raising a negative number to a fractional power.

Temperature Range

Operating and Storage: 0° to 45°C (32° to 113°F)

Accuracy of the Parabolic Coefficients

Data which is clustered in x (small x) and far from the y axis can lead to inaccuracies in the parabolic coefficients. To obtain the greatest accuracy in the parabolic coefficients, you should subtract large offsets from the x data. Consider the following data gathered by a high school coach on four members of his track team.

Height (cm)		100 yd. Dash
Raw Data	Offset Removed	Time (sec.)
175	5	11.6
175	5	11.5
176	6	11.8
176	6	11.7
177	7	11.3
177	7	10.9

If he takes no account of the large offset in the x data and simply enters it in raw form, the parabolic coefficients will be in error by 33% (see drawing). By subtracting 170 cm from each x value, however, the accuracy of the coefficients is improved to .0006%. The effect of this improvement can be seen in the following curve plots.

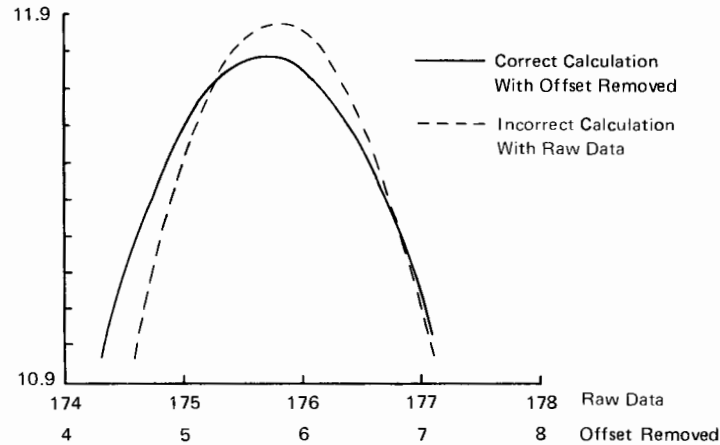

The surest way of appraising coefficient errors is to re-enter the data with the offset removed and examine the change in the coefficient C. This coefficient is (in the absence of errors) independent of data translations. In addition, a graph of the data and the calculated parabolic curve fit will greatly assist in the detection of possible coefficient errors due to large x data offset.

Calculator Checkout Procedure

If the calculator fails to turn on properly (see Step 4 of the 'Turn-on Procedure'), check these possible causes:

- Is the calculator set to operate on the correct line voltage?
- Is the fuse burned out? (examine the filament inside the fuse) Follow Steps 2a and 2c of the 'Turn-on Procedure' when checking or replacing the fuse.

If the calculator prints anything but 'CLEAR' when it's switched on, carefully press the keys in each step of the following procedure; then compare the results with those shown.

NOTE: Be sure **PRINT** and **AUTO** are *not* pressed down!

- | | | |
|-----------|---|----------------------------|
| 1. Press: | CLEAR RND (1) . 0.00000000 00 | CLEAR |
| 2. Press: | 1 . 0 2
3 4 5 6 7
8 9 1.023456789 00 | |
| 3. Press: | PRINT 1.023456789 00 | 1.023456789 00 # |
| 4. Press: | STORE 1.023456789 00 | 1.023456789 00 → |
| 5. Press: | CLEAR 0.00000000 00 | CLEAR |
| 6. Press: | RECALL 1.023456789 00 | 1.023456789 00 ← |
| 7. Press: | RND (1) 2 1.02 | |
| 8. Press: | 6 - 6.00 | 6.00 - |
| 9. Press: | 5 + 1 = 2.00 | 5.00 +
1.00 =
2.00 R |

10. Press:	\times	2.00	2.00	x
11. Press:	5 \div 2 =	5.00	5.00	+
			2.00	=
12. Press:	+	5.00	5.00	R
			5.00	+
13. Press:	5 \uparrow	10.00	5.00	†
14. Press:	2 =	100.00	2.00	=
15. Press:	SHIFT \div	2.00	100.00	R
			100.00	19
16. Press:	SHIFT +	7.39	2.00	g
17. Press:	SHIFT \times	2.00	7.39	ln
18. Press:	+ 5 %	0.10	2.00	+
			5.00	%
19. Press:	=	2.10	.10	=
			2.10	R
20. Press:	SHIFT \uparrow	0.48	2.10	½
21. Press:	SHIFT -	0.04	.48	½
22. Press:	SHIFT (PRINT	0.04	.04	#
23. Press:	SHIFT =	109.10	109.10	RT

If your printout (and display) results do not compare with the samples, or if the calculator has a problem not checked by the above procedure (for example, the **LINE** switch does not stay down, or some characters are not printed correctly), contact the nearest -hp- Sales and Service Office for assistance; office locations are listed at the end of this section.

Statistical Functions Checkout

Once you've verified calculator operation by performing the previous checkout, carefully do each step of this procedure to verify your calculator stat functions:

NOTE
If a plotter is not available, *skip* the steps numbered in green.

- On the plotter:
Press the **LINE ON(IN)** switch down. Then place a sheet of 8½" x 11" paper on the platen and press the **CHART HOLD** switch down. Now set the Graph Limits Controls (set the **LOWER LEFT** controls first) about one-inch in from the corners of the paper (see the sample plot on Page 68). Be sure the plotter is properly connected to the calculator.

One-Variable Function (return to step 2 if an error is made)

- Press: **CLEAR** **RND(1)** **2**

- Press: **VAR #** **1**

- Press: **OFFSET WIDTH** **0** **DATA ENTRY** **1** **DATA ENTRY**

- Press: **1** **DATA ENTRY** **2** **DATA ENTRY** **3** **DATA ENTRY** **3**
DATA ENTRY **3** **DATA ENTRY** **4** **DATA ENTRY** **4** **DATA ENTRY**
4 **DATA ENTRY** **4** **DATA ENTRY**

- Verify the printout for step 5,



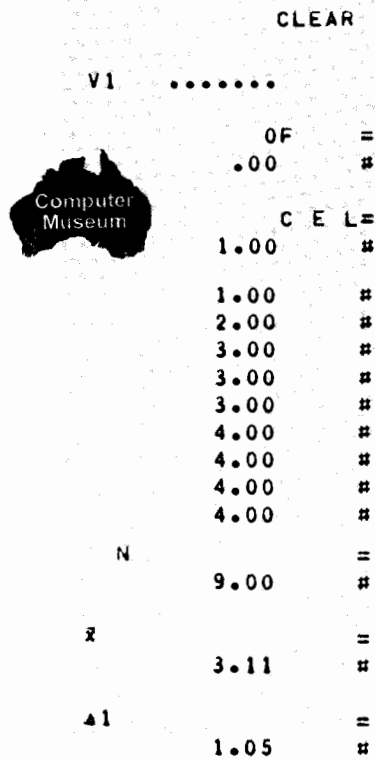

then press **BASIC STAT**





7. Press: 

Printout:





HG				
1.00	#		6.00	#
.00	#		5.00	#
.00	#		.00	#
.00	#		.00	#
2.00	#		7.00	#
1.00	#		6.00	#
1.00	#		.00	#
11.11	#		.00	#
3.00	#		8.00	#
2.00	#		7.00	#
1.00	#		.00	#
11.11	#		.00	#
4.00	#		9.00	#
3.00	#		8.00	#
3.00	#		.00	#
33.33	#		.00	#
5.00	#		10.00	#
4.00	#		9.00	#
4.00	#		.00	#
44.44	#		.00	#

8. Press:     

0.00 →
RG1 =
.00 #
5.00 #

9. Press:   

RG2 =
.00 #
5.00 #

10. Press:    

1.00 →
T 1 =
1.00 #
1.00 #

11. Press: 0 STORE AXES 4

.00 →
AI =
.00 #
.00 #

The X and Y axes should now be plotted (see the sample plot).

12. Press: PLOT The complete histogram (see the sample plot) should now be plotted.

Two-Variable Functions (return to step 13 if an error is made)

13. Press: CLEAR RND 1 2

CLEAR

14. Press: VAR # 2

V2

15. Press: 0 STORE 6 AXES 1

.00 →
RG1 =
.00 #
6.00 #

16. Press: 6 AXES 2

RG2 =
.00 #
6.00 #

17. Press: 1 STORE AXES 3

1.00 →
T I =
1.00 #
1.00 #

18. Press: 0 STORE AXES 4

.00 →
AI =
.00 #
.00 #

The X axis should be plotted directly over the previous one; however, the Y axis will include different tic marks (see green tic marks on the sample plot).

19. Press: CHAR # 2

CT2

20. Press: 1 DATA ENTRY 1 DATA ENTRY

1.00 #
1.00 #

21. Press: 5 DATA ENTRY 2 DATA ENTRY

5.00 #
2.00 #

22. Press: LINEAR

A =
.75 #
B =
.25 #
R² =
1.00 #

23. Press: PLOT

The linear regression is now plotted (see green plot on Page 68).

24. Press: CHAR # 3

CT3

25. Press: DELETE

DEL

26. Press: 5 DATA ENTRY 5 DATA ENTRY
4 DATA ENTRY 2 DATA ENTRY
5 DATA ENTRY 1 DATA ENTRY

5.00 #
5.00 #
4.00 #
2.00 #
5.00 #
1.00 #

27. Press: PARA

A =
- 3.67 #
B =
5.75 #
C =
- 1.08 #
R² =
- .57 #

28. Press: **PLT**

The parabolic curve is now plotted (see the red plot on Page 68).

Paired Statistics Function (return to Step 29 if an error is made)

29. Press: **CLEAR** **VAR #** **0**

30. Press: **1** **DATA ENTRY** **2** **DATA ENTRY** **3** **DATA ENTRY**

Press: **CHANGE SAMPLE**

Press: **5** **DATA ENTRY** **4** **DATA ENTRY** **3** **DATA ENTRY**

31. Press: **BASIC STAT**

32. Press: **t**

```
CLEAR
2T .....
DATA 1
1.00 #
2.00 #
3.00 #
DATA 2
5.00 #
4.00 #
3.00 #
N1
3.00 #
x
2.00 #
A1
1.00 #
N2
3.00 #
y
4.00 #
A2
1.00 #
T
2.45 #
D
4.00 #
```

If your printout does not compare with the sample, return to the indicated step in the checkout and try again. If you still cannot verify the operation, contact the nearest -hp- Sales and Service Office for assistance.

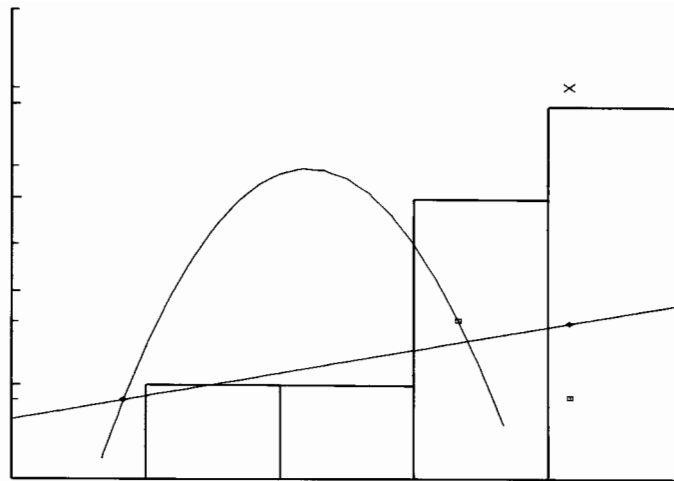

Statistical Functions Checkout Plot

Replacing Printer Paper

The Model 5 is furnished with two rolls of printer paper. If you wish to purchase paper other than that supplied by -hp-, many replacement products are available - just be sure to specify 2¼" wide, adding machine paper.

When replacing the printer paper:

1. Be sure to remove any remaining old paper before loading the new roll.
2. After folding the free end of the new paper and inserting it into the printer as shown in the diagram on the printer, press  and guide the advancing paper under the paper tear-off bracket.

Replacing Printer Ribbon

The printer ribbon supplied should give many months of reliable service, but when the printout becomes light or intermittent, the ribbon needs replacing. Any adding machine ribbon equivalent to either the one supplied or any of the products listed below can be used.

- General Ribbon Co.; type E200, black and red intense ribbon.
- Columbia Ribbon Co.; type 43, black-red record, double-spool ribbon.

When replacing the printer ribbon:

1. Notice the path of the old ribbon before removing it. (See the following diagram.)
2. Be sure the black portion of the new ribbon is up when installed.
3. Press **PAPER** to draw the ribbon taut before closing the calculator top cover.

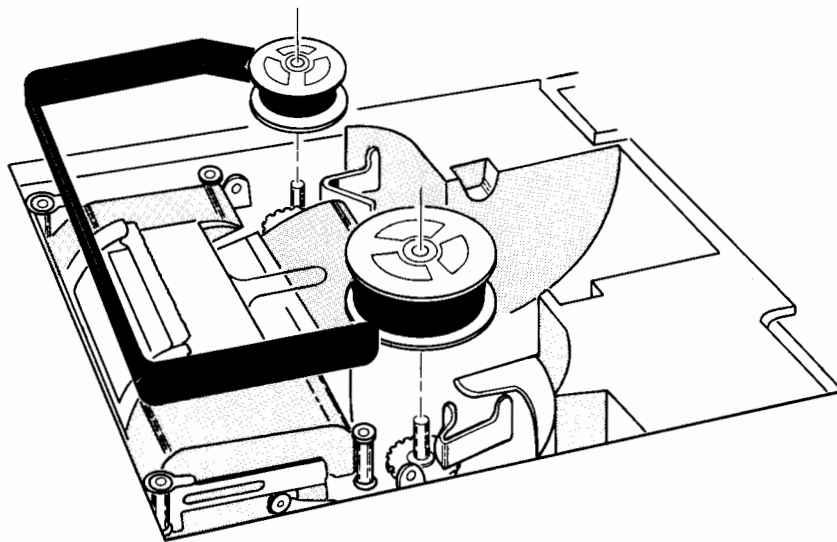

Ribbon Installation

Cleaning The Printer

To ensure clear printouts, it's recommended that the printer be cleaned at least every 3 months. The only equipment needed to clean the printer is a typewriter cleaning brush (any small, stiff-bristled brush will do) and a *small* amount of denatured (isopropyl) alcohol.

To clean the printer:

1. Remove the printer paper; then lift up the paper tear-off bracket and lift off the small, metal cover plate (see the next photo).
2. Remove the ribbon and inspect it for wear; if it looks frayed or perforated, install a new one in Step 6.
3. Slide a strip of printer paper about 6" long under and around the metal print drum as shown. This paper will catch the ribbon and paper particles brushed from the print drum.
4. Use the stiff-bristled brush and a *small* amount of alcohol to clean each character on the print drum.

CAUTION

BE SURE ALCOHOL DOES NOT GET ON ANY COMPONENTS EXCEPT THE PRINT DRUM.

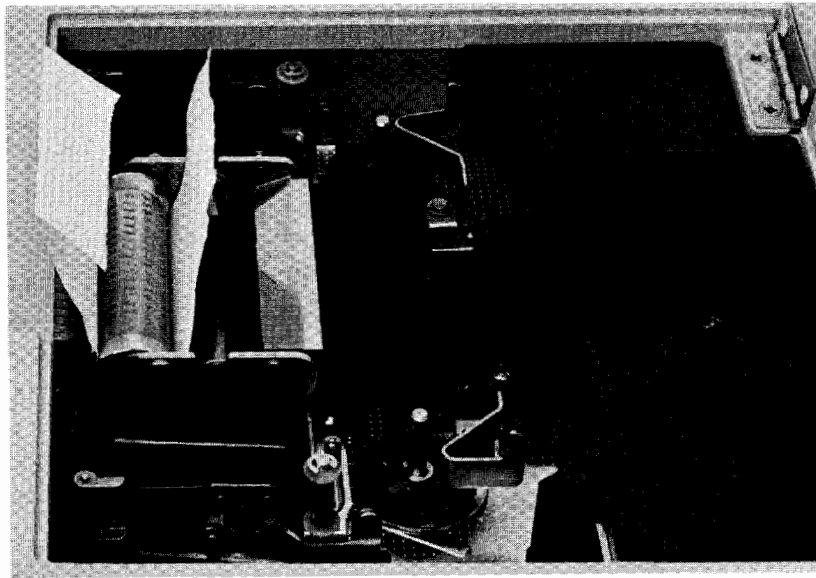

5. After you've cleaned the drum, fold the paper as shown and slowly pull the paper back out from under the drum. Now blow any dust or remaining ribbon particles out of the printer.
6. Replace the small cover plate, snap the paper tear-off bracket back into place, then replace the ribbon and the printer paper.

Cleaning The Calculator

The calculator can be cleaned with a soft cloth dampened either in clean water or in water containing a mild detergent. Do not use an excessively wet cloth nor allow water to penetrate inside the calculator. Also, do not use any abrasive cleaners, especially on the display window.

**ELECTRONIC
SALES & SERVICE OFFICES**

UNITED STATES

ALABAMA

P.O. Box 4207
2003 Byrd Spring Road S.W.
Huntsville 35802
Tel: (205) 881-4591
TWX: 810-726-2204

ARIZONA

2336 E. Magnolia St.
Phoenix 85034
Tel: (602) 252-5061
TWX: 910-951-1330

5737 East Broadway
Tucson 85716
Tel: (602) 298-2313
TWX: 910-952-1162

CALIFORNIA

1430 East Orangethorpe Ave.
Fullerton 92631
Tel: (714) 870-1000

5939 Lankershim Boulevard
North Hollywood 91604
Tel: (213) 877-1282
TWX: 910-499-2170

1101 Embarcadero Road
Palo Alto 94303
Tel: (415) 327-6500
TWX: 910-373-1280

2220 Watt Ave.
Sacramento 95825
Tel: (916) 482-1463
TWX: 910-367-2092

9606 Aero Drive
San Diego 92123
Tel: (714) 279-3200
TWX: 910-335-2000

COLORADO

7965 East Prentice
Englewood 80110
Tel: (303) 771-3455
TWX: 910-935-0705

CONNECTICUT

12 Lunar Drive
New Haven 06525
Tel: (203) 389-6551
TWX: 910-465-2029

FLORIDA

P.O. Box 24210
2806 W. Oakland Park Blvd.
Fl. Lauderdale 33307
Tel: (305) 731-2020
TWX: 510-955-4099

P.O. Box 13910
6177 Lake Ellenor Dr.
Orlando 32809
Tel: (305) 859-2900
TWX: 810-850-0113

GEORGIA

P.O. Box 28234
450 Interstate North
Atlanta 30328
Tel: (404) 436-6181
TWX: 810-766-4890

HAWAII

2875 So. King Street
Honolulu 96814
Tel: (808) 955-4455

ILLINOIS

5500 Howard Street
Skokie 60076
Tel: (312) 677-0400
TWX: 910-223-3613

INDIANA

3839 Meadows Drive
Indianapolis 46205
Tel: (317) 546-4891
TWX: 810-341-3263

LOUISIANA

P.O. Box 856
1942 Williams Boulevard
Kenner 70062
Tel: (504) 721-6201
TWX: 810-955-5524

MARYLAND

6707 Whitestone Road
Baltimore 21207
Tel: (301) 944-5400
TWX: 710-862-9157

P.O. Box 1648

2 Choke Cherry Road
Rockville 20850
Tel: (301) 948-6370
TWX: 710-828-9684

MASSACHUSETTS

32 Hartwell Ave.
Lexington 02173
Tel: (617) 861-8960
TWX: 710-326-6904

MICHIGAN

21840 West Nine Mile Road
Southfield 48075
Tel: (313) 353-9100
TWX: 810-224-4882

MINNESOTA

2459 University Avenue
St. Paul 55114
Tel: (612) 645-9461
TWX: 510-563-3734

MISSOURI

11131 Colorado Ave.
Kansas City 64137
Tel: (816) 763-8000
TWX: 910-771-2087

148 Weldon Parkway
Maryland Heights 63043
Tel: (314) 567-1455
TWX: 910-764-0830

NEW JERSEY

W. 120 Century Road
Paramus 07652
Tel: (201) 265-5000
TWX: 710-990-4951

1060 N. Kings Highway
Cherry Hill 08034
Tel: (609) 667-4000
TWX: 710-892-4945

NEW MEXICO

P.O. Box 8366
Station C
6501 Lomas Boulevard N.E.
Albuquerque 87108
Tel: (505) 265-3713
TWX: 910-989-1665

156 Wyatt Drive
Las Cruces 88001
Tel: (505) 526-2485
TWX: 910-983-0550

NEW YORK

6 Automation Lane
Computer Park
Albany 12205
Tel: (518) 458-1550
TWX: 710-441-8270

1219 Campville Road
Endicott 13760
Tel: (607) 754-0050
TWX: 510-252-0890

82 Washington Street
Poughkeepsie 12601
Tel: (914) 454-7330
TWX: 510-248-0012

39 Saginaw Drive
Rochester 14623
Tel: (716) 473-9500
TWX: 510-253-5981

5858 East Molloy Road
Syracuse 13211
Tel: (315) 454-2486
TWX: 710-541-0482

1 Crossways Park West
Woodbury 11797
Tel: (516) 921-0300
TWX: 510-223-0811

NORTH CAROLINA

P.O. Box 5188
1923 North Main Street
High Point 27262
Tel: (919) 886-6101
TWX: 510-526-1516

OHIO

25575 Center Ridge Road
Cleveland 44145
Tel: (216) 835-0300
TWX: 810-427-9129

3460 South Dixie Drive
Dayton 45439
Tel: (513) 298-0351
TWX: 810-459-1925

1120 Morse Road
Columbus 43229
Tel: (614) 846-1300

OKLAHOMA

6301 N. Meridian Avenue
Oklahoma City 73122
Tel: (405) 721-0200
TWX: 910-830-6862

OREGON

Westhill Mall, Suite 158
4475 S.W. Scholls Ferry Road
Portland 97225
Tel: (503) 292-9171
TWX: 910-464-6103

PENNSYLVANIA

2500 Moss Side Boulevard
Monroeville 15146
Tel: (412) 271-0724
TWX: 710-797-3650

1021 8th Avenue
King of Prussia Industrial Park
King of Prussia 19406
Tel: (215) 265-7000
TWX: 510-660-2670

RHODE ISLAND

873 Waterman Ave.
East Providence 02914
Tel: (401) 434-5535
TWX: 710-381-7573

***TENNESSEE**

Memphis
Tel: (901) 274-7472

TEXAS

P.O. Box 1270
201 E. Arapaho Rd.
Richardson 75080
Tel: (214) 231-6101
TWX: 910-867-4723

P.O. Box 27409
6300 Westpark Drive
Suite 100
Houston 77027
Tel: (713) 781-6000
TWX: 910-881-2645

231 Billy Mitchell Road
San Antonio 78226
Tel: (512) 434-4171
TWX: 910-871-1170

UTAH

2890 South Main Street
Salt Lake City 84115
Tel: (801) 487-0715
TWX: 810-925-5681

VERMONT

P.O. Box 2287
Kennedy Drive
South Burlington 05401
Tel: (802) 558-4455
TWX: 510-299-0025

VIRGINIA

P.O. Box 6514
2111 Spencer Road
Richmond 23230
Tel: (703) 285-3431
TWX: 710-956-0157

WASHINGTON

433-108th N.E.
Bellevue 98004
Tel: (206) 454-3971
TWX: 910-443-2303

***WEST VIRGINIA**

Charleston
Tel: (304) 768-1232

FOR U.S. AREAS NOT LISTED:

Contact the regional office nearest you: Atlanta, Georgia . . . North Hollywood, California . . . Paramus, New Jersey . . . Skokie, Illinois. Their complete addresses are listed above.

*Service Only

CANADA

ALBERTA

Hewlett-Packard (Canada) Ltd.
11748 Kingsway Ave.
Edmonton
Tel: (403) 452-3670
TWX: 610-831-2431

BRITISH COLUMBIA

Hewlett-Packard (Canada) Ltd.
4519 Canada Way
North Burnaby 2
Tel: (604) 433-9213
TWX: 610-922-5059

MANITOBA

Hewlett-Packard (Canada) Ltd.
513 Century St.
Winnipeg
Tel: (204) 786-7581
TWX: 610-671-3531

NOVA SCOTIA

Hewlett-Packard (Canada) Ltd.
2745 Dutch Village Rd.
Suite 206
Halifax
Tel: (902) 455-0511
TWX: 610-271-4482

ONTARIO

Hewlett-Packard (Canada) Ltd.
1785 Woodward Dr.
Ottawa 3
Tel: (613) 255-6180, 255-6530
TWX: 610-562-1952

Hewlett-Packard (Canada) Ltd.

50 Galaxy Blvd.
Rexdale
Tel: (416) 677-9611
TWX: 610-492-4246

QUEBEC

Hewlett-Packard (Canada) Ltd.
275 Hymus Boulevard
Pointe Claire
Tel: (514) 697-4232
TWX: 610-422-3022
Telex: 01-20607

FOR CANADIAN AREAS NOT LISTED:

Contact Hewlett-Packard (Canada) Ltd. in Pointe Claire, at the complete address listed above.

CENTRAL AND SOUTH AMERICA

ARGENTINA
Hewlett-Packard Argentina
S.A.C.e.l
Lavalle 1171 - 3°
Buenos Aires
Tel: 35-0436, 35-0627, 35-0431
Telex: 012-1009
Cable: HEWPACK ARG

BRAZIL
Hewlett-Packard Do Brasil
I.E.C. Ltda.
Rua Frei Caneca 1119
Sao Paulo - J, SP
Tel: 288-7111, 287-5858
Cable: HEWPACK Sao Paulo

Hewlett-Packard Do Brasil
Praca Dom Feliciano 78
Salas 806/808
Porto Alegre
Rio Grande do Sul (RS)-Brasil
Tel: 25-8470
Cable: HEWPACK Porto Alegre

Hewlett-Packard Do Brasil
I.E.C. Ltda.
Rua da Matriz 29
Botafogo ZC-02
Rio de Janeiro, GB
Tel: 246-4417, 246-2919
Cable: HEWPACK Rio de Janeiro

CHILE
Héctor Calcagni y Cia, Ltda.
Casilla 16 475
Santiago
Tel: 423 96
Cable: CALCAGNI Santiago

COLOMBIA
Instrumentacion
Henrik A. Langebaek & Kier S.A.
Carrera 7 No. 48-59
Apartado Aereo 6287
Bogota, 1 D.E.
Tel: 45-78-06, 45-55-46
Cable: AARIS Bogota
Telex: 44400INSTCO

COSTA RICA
Lic. Alfredo Callegos Curdián
Apartado 10159
San José
Tel: 21-86-13
Cable: GARGUR San José

ECUADOR
Laboratorios de Radio-Ingengeria
Calle Guayaquil 1246
Post Office Box 3199
Quito
Tel: 212-496; 219-185
Cable: HORVATH Quito

EL SALVADOR
Electronic Asociates
Apartado Postal 1682
Centro Comercial Gigante
San Salvador, El Salvador C.A.
Pasaje Escalon 4649-4° Piso
Tel: 23-44-50, 23-32-37
Cable: ELECAS

GUATEMALA
IPESA
5a via 2-01, Zona 4
Guatemala City
Tel: 63-6-27 & 64-7-86
Telex: 4176 Mahohegu

MEXICO
Hewlett-Packard Mexicana, S.A.
de C.V.
622 Adolfo Prieto
Cpl. del Valle
Mexico 12, D.F.
Tel: 543-4232; 523-1874
Telex: 017-74-507

NICARAGUA
Roberto Terán G.
Apartado Postal 689
Edificio Terán
Managua
Tel: 3451, 3452
Cable: ROTERAN Managua

PANAMA
Electrónico Balboa, S.A.
P.O. Box 4929
Ave. Manuel Espinosa No. 13-50
Bldg. Alina
Panama City
Tel: 230833
Telex: 3481003, Curundu,
Canal Zone
Cable: ELECTRON Panama City

PARAGUAY
Z.T. Melamed S.R.L.
Division: Aparatos y Equipos
Medicos
Salon de Exposicion y Escritorio:
Chile 482
Edificio Victoria—Planta Baja
Asuncion, Paraguay
Tel: 4-5069, 4-6272
Cable: RAMEL

URUGUAY
Pablo Ferrando S.A.
Comercial e Industrial
Avenida Italia 2877
Casilla de Correo 370
Montevideo
Tel: 40-3102
Cable: RADIUM Montevideo

VENEZUELA
Hewlett-Packard De Venezuela
C.A.
Apartado 50933
Caracas
Tel: 71.88.05, 71.88.69, 71.99.30
Cable: HEWPACK Caracas
Telex: 21146 HEWPACK

PERU
Compañía Electro Medica S.A.
Ave. Enrique Canaval 312
San Isidro
Casilla 1030
Lima
Tel: 22-3900
Cable: ELMED Lima

PUERTO RICO
San Juan Electronics, Inc.
P.O. Box 5167
Ponce de Leon 154
Pda. 3-PTA de Tierra
San Juan 00906
Tel: (809) 725-3342, 722-3342
Cable: SATRONICS San Juan
Telex: SATRON 3450 332



EUROPE

AUSTRIA
Hewlett-Packard Ges.m.b.H
Handelskai 52/3
P.O. Box 7
A-1205 Vienna
Tel: (0222) 33 66 06 to 09
Cable: HEWPAK Vienna
Telex: 75923 hewpak a

BELGIUM
Hewlett-Packard Benelux
S.A./N.V.
Avenue du Col-Vert, 1
B-1170 Brussels
Tel: (02) 72 22 40
Cable: PALOBN Brussels
Telex: 23 494

DENMARK
Hewlett-Packard A/S
Datavej 38
DK-3460 Birkerød
Tel: (01) 81 66 40
Cable: HEWPACK AS
Telex: 16640 hp as

Hewlett-Packard A/S
Torvet 9
DK-8600 Silkeborg
Tel: (06) 82-71-66
Telex: 16640 hp as
Cable: HEWPACKAS

FINLAND
Hewlett-Packard Oy
Bulevardi 26
P.O. Box 12185
SF-00120 Helsinki 12
Tel: (90) 13730
Cable: HEWPACKOY-Helsinki
Telex: 17-1563 hel

FRANCE
Hewlett-Packard France
Quartier de Courtabouet
Boite Postale No. 6
F-91401 Orsay
Tel: (1) 907 78 25
Cable: HEWPACK Orsay
Telex: 60048

Hewlett-Packard France
4 Quai des Etoiles
F-69321 Lyon Cedex 1
Tel: (78) 42 63 45
Cable: HEWPACK Lyon
Telex: 31617

Hewlett-Packard France
29 rue de la Gare
F-31700 Blagnac
Tel: (61) 85 62 29
Telex: 51957

**GERMAN FEDERAL
REPUBLIC**
Hewlett-Packard Vertriebs-GmbH
Berliner Strasse 117
Postfach 560 140
O-6 Nieder-Eschbach/Ffm 56
Tel: (0611) 50-04 1
Cable: HEWPACKSA Frankfurt
Telex: 41 32 49 FRA

Hewlett-Packard Vertriebs-GmbH
Herrenbergerstrasse 110
D-7030 Boblingen, Württemberg
Tel: (07031) 66 72 87
Cable: HEPAK Boblingen
Telex: 72 65 739 bbn

Hewlett-Packard Vertriebs-GmbH
D-4 Büsselfeld
Tel: (0211) 63 80 31/35
Telex: 85/86 533 hpdd d

Hewlett-Packard Vertriebs-GmbH
Wendenstr. 23
D-2 Hamburg 1
Tel: (0411) 24 05 51/52
Cable: HEWPACKSA Hamburg
Telex: 21 53 032 hphh d

Hewlett-Packard Vertriebs-GmbH
Unterhachinger Strasse 28
ISAR Center
D-8012 Ottobrunn
Tel: (0811) 601 30 61/7
Telex: 52 49 85
Cable: HEWPACKSA München

(West Berlin)
Hewlett-Packard Vertriebs-GmbH
Wilmsdorfer Strasse 113/114
D-1000 Berlin W. 12
Tel: (0311) 3137046
Telex: 18 34 05 hpolm d

GREECE
Kostas Karayannis
18, Ermou Street
Athens 126
Tel: 3230-303
Cable: RAKAR Athens
Telex: 21 59 62 rkar gr

IRELAND
Hewlett-Packard Ltd.
224 Bath Road
Slough, SL1 4 DS, Bucks
Tel: Slough (0753) 33341
Cable: HEWPIE Slough
Telex: 84413

Hewlett-Packard Ltd.
The Grifflons
Slamford New Road
Altrincham, Cheshire, England
Tel: (061) 928-8625
Telex: 668068

ITALY
Hewlett-Packard Italiana S.p.A.
Via Amerigo Vespucci 2
I-20124 Milan
Tel: (2) 6251 (10 lines)
Cable: HEWPACKIT Milan
Telex: 32046

Hewlett-Packard Italiana S.p.A.
Piazza Marconi
I-00144 Rome - Eur
Tel: (6) 5912544/5, 5915947
Cable: HEWPACKIT Rome
Telex: 63154

Hewlett-Packard Italiana S.p.A.
Vicolo Pastori, 3
I-35100 Padova
Tel: (49) 66 40 62
Telex: 32046 via Milan

Hewlett-Packard Italiana S.p.A.
Via Colli, 24
I-10129 Turin
Tel: (11) 53 62 64
Telex: 32046 via Milan

LUXEMBURG
Hewlett-Packard Benelux
S.A./N.V.
Avenue du Col-Vert, 1
B-1170 Brussels
Tel: (03/02) 72 22 40
Cable: PALOBN Brussels
Telex: 23 494

NETHERLANDS
Hewlett-Packard Benelux, N.V.
Weerdestein 117
P.O. Box 7825
Amsterdam, Z 11
Tel: 020-42 77 77
Cable: PALOBN Amsterdam
Telex: 13 216 hepa nl

NORWAY
Hewlett-Packard Norge A/S
Box 149
Hesviken 13
N-1344 Haslum
Tel: (02)-53 83 60
Cable: 16621 hpnas n

PORTUGAL
Electra-Empresa Tecnica de
Equipamentos
Electricos S.a.r.l.
Rua Rodrigo da Fonseca 103
P.O. Box 2531
P-Lisbon 1
Tel: (19) 68 60 72
Cable: ELECTRA Lisbon
Telex: 1598

SPAIN
Hewlett-Packard Española, S.A.
Jerez No 8
Madrid 16
Tel: 458 26 00
Telex: 23515 hpe

Hewlett-Packard Española, S.A.
Milanesado, 21-23
E-Barcelona 17
Tel: (3) 203 62 00
Telex: 52603 hobe e

SWEDEN
Hewlett-Packard Sverige AB
Enighetsvägen 1-3
Fack
S-161 20 Bromma 20
Tel: (08) 98 12 50
Cable: MEASUREMENTS
Stockholm
Telex: 10721

Hewlett-Packard Sverige AB
Hagakergatan 9C
S-431 43 Mölndal
Tel: (031) 27 68 00/01
Telex: 21 312 hpmind s

SWITZERLAND
Hewlett-Packard (Schweiz) AG
Zürcherstrasse 20
P.O. Box 64
CH-8952 Schlieren Zurich
Tel: (01) 98 18 21/24
Cable: HPAC CH
Telex: 53933 hpag ch

Hewlett-Packard (Schweiz) AG
Rue du Bois-du-Lan 7
P.O. Box 85
1217 Meyrin 2 Geneva
Tel: (022) 41 54 00
Cable: HEWPACKSA Geneva
Telex: 27333 hpsa ch

TURKEY
Telekom Engineering Bureau
Saglik Sok No. 15/1
Ayaspaşa-Beyoglu
P.O. Box 437 Beyoglu
Istanbul
Tel: 49 40 40
Cable: TELEMATIION Istanbul

UNITED KINGDOM
Hewlett-Packard Ltd.
224 Bath Road
Slough, SL1 4 DS, Bucks
Tel: Slough (0753) 33341
Cable: HEWPIE Slough
Telex: 84413

Hewlett-Packard Ltd.
"The Grifflons"
Slamford New Road
Altrincham, Cheshire
Tel: (061) 928-8626
Telex: 668068

**SOCIALIST COUNTRIES
PLEASE CONTACT:**
Hewlett-Packard Ges.m.b.H.
Handelskai 52/3
P.O. Box 7
A-1205 Vienna
Ph: (0222) 33 66 06 to 09
Cable: HEWPAK Vienna
Telex: 75923 hewpak a

**ALL OTHER EUROPEAN
COUNTRIES CONTACT:**
Hewlett-Packard S.A.
Rue du Bois-du-Lan 7
P.O. Box 85
CH-1217 Meyrin 2 Geneva
Switzerland
Tel: (022) 41 54 00
Cable: HEWPACKSA Geneva
Telex: 2-24-86

AFRICA, ASIA, AUSTRALIA

ANGOLA
Telectra Empresa Técnica
de Equipamentos Eléctricos
SAR
Rua de Barbosa Rodrigues
42-1°
Box 6487
Luanda
Cable: TELECTRA Luanda

AUSTRALIA
Hewlett-Packard Australia
Pty. Ltd.
22-26 Weir Street
Glen Iris, 3146
Victoria
Tel: 20-1371 (6 lines)
Cable: HEWPARD Melbourne
Telex: 31 024

Hewlett-Packard Australia
Pty. Ltd.
Corner Bridge & West Streets
Pymble, New South Wales, 2073
Tel: 469 6566
Cable: HEWPARD Sydney
Telex: 21561

Hewlett-Packard Australia
Pty. Ltd.
97 Churchhill Road
Prospect 5082
South Australia
Tel: 65-2366
Cable: HEWPARD Adelaide

Hewlett-Packard Australia
Pty. Ltd.
2nd Floor, Suite 13
Casablanca Buildings
156 Adelaide Terrace
Perth, W.A. 6000
Tel: 25 6800
Cable: HEWPARD Perth

Hewlett-Packard Australia
Pty. Ltd.
10 Woolley Street
P.O. Box 191
Dickson A.C.T. 2602
Tel: 49-8194
Cable: HEWPARD Canberra ACT

Hewlett-Packard Australia
Pty. Ltd.
6 Harvard Street
P.O. Box 135
Kenmore 4069 Queensland
Tel: 70-4050

CEYLON
United Electricals Ltd.
P.O. Box 681
Yahala Building
Staples Street
Colombo 2
Tel: 26696
Cable: HOTPOINT Colombo

CYPRUS
Kypronics
19 Gregorios & Xenopoulos Road
P.O. Box 1152
Nicosia
Tel: 45628/29
Cable: Kypronics Paphos

ETHIOPIA
African Salespower & Agency
Private Ltd., Co.
P. O. Box 718
58/59 Cunningham St.
Addis Ababa
Tel: 12285
Cable: ASACO Addisababa

HONG KONG
Schmidt & Co. (Hong Kong) Ltd.
P.O. Box 297
1511 Prince's Building 15th Floor
10, Chater Road
Hong Kong
Tel: 240168, 232735
Cable: SCHMIDTCO Hong Kong

INDIA
Blue Star Ltd.
Kasturi Buildings
Jamshedji Tata Rd.
Bombay 20BR, India
Tel: 29 50 21
Telex: 3751
Cable: BLUEFROST

Blue Star Ltd.
Band Box House
Prabhadevi
Bombay 250D, India
Tel: 45 73 01
Telex: 3751
Cable: BLUESTAR

Blue Star Ltd.
14/40 Civil Lines
Kanpur, India
Tel: 6 88 82
Cable: BLUESTAR

Blue Star, Ltd.
7 Hare Street
P.O. Box 506
Calcutta 1, India
Tel: 23-0131
Telex: 655
Cable: BLUESTAR

Blue Star Ltd.
Blue Star House,
34 Ring Road
Lajpat Nagar
New Delhi 24, India
Tel: 62 32 76
Telex: 463
Cable: BLUESTAR

Blue Star, Ltd.
Blue Star House
11/11A Magarath Road
Bangalore, 25
Tel: 51473
Telex: 430
Cable: BLUESTAR

Blue Star, Ltd.
1-1-117/1
Sarojini Devi Road
Secunderabad 3
Tel: 7 63 91, 7 73 93
Cable: BLUEFROST

Blue Star, Ltd.
23/24 Second Line Beach
Madras 1, India
Tel: 2 39 55
Telex: 379
Cable: BLUESTAR

Blue Star, Ltd.
18 Kaiser Bungalow
Dindli Road
Jamshedpur, India
Tel: 38 04
Cable: BLUESTAR

IRAN
Multicorp International Ltd.
Avenue Soraya 130
P.O. Box 1212
Tehran
Tel: 83 10 35-39
Cable: MULTICORP Tehran
Telex: 2893 mci tn

ISRAEL
Electronics & Engineering
Div. of Motorola Israel Ltd.
17 Aminadav Street
Tel-Aviv
Tel: 36941 (3 lines)
Cable: BASTEL Tel-Aviv
Telex: MOTIL IL

JAPAN
Yokogawa-Hewlett-Packard Ltd.
Ohashi Building
1-59-1 Toyokaji
Shibuya-ku, Tokyo
Tel: 03-370-2281/92
Telex: 232-2024YHP
Cable: YHPMARKET TOK 23-724

Yokogawa-Hewlett-Packard Ltd.
Nisei Ibaragi Bldg.
2-2-8 Kasuga
Ibaragi-Shi
Osaka
Tel: (0726) 23-1641
Telex: 5332 385 YHP OSAKA

Yokogawa-Hewlett-Packard Ltd.
Ito Building
No. 59, Kotori-cho
Nakamura-ku, Nagoya City
Tel: (052) 551-0215

Yokogawa-Hewlett-Packard Ltd.
Nitto Bldg.
2-4-2 Shinohara-Kita
KoHoku-ku
Yokohama 222
Tel: 045-432-1504
Telex: 382-3204 YHP YOK

Yokogawa-Hewlett-Packard Ltd.
Chuo Bldg.
Rm. 603 3,
2-Chome
IZUMI-CHO,
Mito, 310
Tel: 0292-25-7470

KENYA
Kenya Kinetics
P.O. Box 18311
Nairobi, Kenya
Tel: 57226
Cable: PROTON

KOREA
Amtraco Corporation
Industrial Products Div.
Seoul P.O. Box 1103
8th floor, Daekyung Bldg.
107 Sejong Ro
Chongro-Ku, Seoul
Tel: 73-8924-7
Cable: AMTRACO Seoul

LEBANON
Constantin E. Macridis
P.O. Box 7213
Beirut
Tel: 220846
Cable: ELECTRONUCLEAR Beirut

MALAYSIA
MECOMB Malaysia Ltd.
2 Lorong 13/6A
Section 13
Petaling Jaya, Selangor
Cable: MECOMB Kuala Lumpur

MOZAMBIQUE
A. N. Goncalves, LDA.
4.1 Apt. 14 Av. D. Luis
P.O. Box 107
Lourenco Marques
Cable: NEGON

NEW ZEALAND
Hewlett-Packard (N.Z.) Ltd.
94-96 Dixon St.
P.O. Box 9443
Courtenay Place
Wellington, N.Z.
Tel: 56-559
Cable: HEWPACK Wellington

Hewlett-Packard (N.Z.) Ltd.
Box 51092
Pukuranga
Tel: 56-9837
Cable: HEWPACK, Auckland

PAKISTAN
Mushko & Company, Ltd.
Osman Chambers
Abdullah Haroon Road
Karachi 3
Tel: 511027, 512927
Cable: COOPERATOR Karachi

Mushko & Company, Ltd.
38B, Satellite Town
Rawalpindi
Tel: 41924
Cable: FEMUS Rawalpindi

PHILIPPINES
Electromex Inc.
5th Floor, Architects
Center Bldg.
Ayala Ave., Makati, Rizal
C.C.P.O. Box 1028
Makati, Rizal
Tel: 86-18 87, 87-76-77
Cable: ELEMEX Manila

SINGAPORE
Mechanical and Combustion
Engineering Company Ltd.
9, Jalan Kilang
Red Hill Industrial Estate
Singapore, 3
Tel: 642361-3, 632611
Cable: MECOMB Singapore

Hewlett-Packard Far East
Area Office
P.O. Box 87
Alexandra Post Office
Singapore 3
Tel: 633022
Cable: HEWPACK SINGAPORE

SOUTH AFRICA
Hewlett-Packard South Africa
(Pty.), Ltd.
P.O. Box 31716
Braamfontein Transvaal
Milnerlon
30 De Beer Street
Johannesburg
Tel: 725-2080, 725-2030
Telex: 0226 JH
Cable: HEWPACK Johannesburg

Hewlett-Packard South Africa
(Pty.), Ltd.
Breechle House
Bree Street

Cape Town
Tel: 3-6D19, 3-6545
Cable: HEWPACK Cape Town
Telex: 5-0006

Hewlett-Packard South Africa
(Pty.), Ltd.
641 Ridge Road, Ourban
P.O. Box 99
Overport, Natal
Tel: 88-6102
Telex: 567954
Cable: HEWPACK

TAIWAN
Hewlett-Packard Taiwan
39 Chung Shiao West Road
Sec. 1
Overseas Insurance
Corp. Bldg. 7th Floor
Taipei
Tel: 389160, 1, 2, 375121,
Ext: 240-249
Telex: TP824 HEWPACK
Cable: HEWPACK Taipei

THAILAND
UNIMESA Co., Ltd.
Chongkolnee Building
56 Suriwongse Road
Bangkok
Tel: 37956, 31300, 31307,
37540
Cable: UNIMESA Bangkok

UGANDA
Uganda Tele Electric Co., Ltd.
P.O. Box 4449
Kampala
Tel: 57279
Cable: COMCO Kampala

VIETNAM
Peninsular Trading Inc.
P.O. Box H-3
216 Hien-Vuong
Saigon
Tel: 20-805, 93398
Cable: PENTRA, SAIGON 242

ZAMBIA
R. J. Tilbury (Zambia) Ltd.
P.O. Box 2792
Lusaka
Zambia, Central Africa
Tel: 73793
Cable: ARIAYTEE, Lusaka

**MEDITERRANEAN AND
MIDDLE EAST COUNTRIES
NOT SHOWN PLEASE
CONTACT:**
Hewlett-Packard
Co-ordination Office for
Mediterranean and Middle
East Operations
Via Marocco, 7
I-00144 Rome-Eur, Italy
Tel: (6) 59 40 29
Cable: HEWPACKIT Rome
Telex: 61514

**OTHER AREAS NOT
LISTED, CONTACT:**
Hewlett-Packard
INTERCONTINENTAL
3200 Hillview Ave.
Palo Alto, California 94304
Tel: (415) 326-7000
(Feb. 71 493-1501)
TWX: 910-373-1267
Cable: HEWPACK Palo Alto
Telex: 034-8300, 034-8493

Operating Information

t Table

D.F.	90%	95%	98%	99%
1	6.31	12.7	31.8	63.7
2	2.92	4.31	6.96	9.92
3	2.35	3.18	4.54	5.84
4	2.13	2.78	3.75	4.60
5	2.02	2.57	3.36	4.03
6	1.94	2.45	3.14	3.71
7	1.90	2.36	3.00	3.50
8	1.86	2.31	2.90	3.36
9	1.83	2.26	2.82	3.25
10	1.81	2.23	2.76	3.17
12	1.78	2.18	2.68	3.06
14	1.76	2.14	2.62	2.98
16	1.75	2.12	2.58	2.92
18	1.73	2.10	2.55	2.88
20	1.72	2.09	2.53	2.84

Notation & Formulas

Notation:

y_i = Dependent or response variable

x_i = Independent or predictor variable

n = Number of (x_i, y_i) pairs, $i=1, 2, \dots, n$

\bar{x} = Mean of the independent variable

\bar{y} = Mean of the dependent variable

Mean and Standard Deviation:

$$\bar{x} = \frac{1}{n} \sum_{i=1}^n x_i$$

$$\Delta x = \sqrt{\frac{1}{n-1} U_x}$$

$$\bar{y} = \frac{1}{n} \sum_{i=1}^n y_i$$

$$\Delta y = \sqrt{\frac{1}{n-1} U_y}$$

Linear Regression:

A = Intercept

B = Slope

$$= \frac{1}{n} \left[\sum_{i=1}^n y_i - B \sum_{i=1}^n x_i \right] = \frac{U_{xy}}{U_x}$$

r^2 = Square of the correlation coefficient

$$= \frac{(U_{xy})^2}{U_x U_y}$$

Parabolic Regression:

A = Intercept

B = Linear coefficient

$$= \frac{1}{n} \left[\sum_{i=1}^n y_i - C x_i^2 - B \sum_{i=1}^n x_i \right] = \frac{U_{xy} - C U_{xx^2}}{U_x}$$

(continued)

$$C = \text{Quadratic coefficient} \quad \frac{U_x U_x^2 y - U_x x^2 U_{xy}}{U_x U_x^2 - (U_x x^2)^2}$$

$$r^2 = \text{Square of the multiple correlation coefficient} \quad \frac{B U_{xy} + C U_x^2 y}{U_y}$$

Two-Sample t:

$$t = \frac{\bar{x} - \bar{y}}{\sqrt{\frac{(n_1 - 1) \Delta_1^2 + (n_2 - 1) \Delta_2^2}{n_1 + n_2 - 2} \left(\frac{1}{n_1} + \frac{1}{n_2} \right)}}$$

$$\text{Degrees of Freedom} = n_1 + n_2 - 2$$

Paired t:

$$t = \frac{\bar{d}}{\sqrt{\frac{\Delta_d^2}{n}}} \quad d_i = (x_i - y_i)$$

$$\text{Degrees of Freedom} = n - 1$$

$n = \#$ of pairs of observations

$\Delta_d =$ standard deviation of the differences between pairs of observations.

Intermediate Equations

$$U_x = \sum_{i=1}^n (x_i - \bar{x})^2$$

$$U_y = \sum_{i=1}^n (y_i - \bar{y})^2$$

$$U_x^2 = \sum_{i=1}^n (x_i^2 - \bar{x}^2)^2$$

$$U_{xx^2} = \sum_{i=1}^n (x_i - \bar{x})(x_i^2 - \bar{x}^2)$$

$$U_{xy} = \sum_{i=1}^n (x_i - \bar{x})(y_i - \bar{y})$$

$$U_x^2 y = \sum_{i=1}^n (x_i^2 - \bar{x}^2)(y_i - \bar{y})$$

Glossary

Analysis of Variance*

Analysis of variance is the method statistician's use to split the total variation in data into its various sources. For example, when using the regression $y = A + Bx + B_1 x + \dots$, you can split the total variation of y about \bar{y} into two parts (the variation explained by regression and the unexplained variation). Then, you can use certain ratios of the variations to test the addition of new variables to the fit or to test the significance of the fit.

Average

Average is synonymous with *Mean* and is defined as $1/n (x_1 + x_2 + \dots + x_n)$. It is symbolized as \bar{x} (pronounced 'x bar').

Coefficient of Determination (r^2)

The coefficient of determination is a measure of the goodness of fit in a regression. It is the square of the *Correlation Coefficient* (R).

Coefficients of Regression

In the regression equation $y = A + B_1 x + B_2 x + \dots$, the constants A , B_1 , B_2 , . . . are called the coefficients of the regression equation.

Confidence Statements

Confidence statements are predictions made on the basis of the regression equation. For example, with a confidence level of 95%, you are saying that the true value of a predicted y lies somewhere between 90 and 96.

*These Functions are available with the Expanded Stat Programs Block.

Correlation

The degree of interdependence between two variables is called the correlation. Correlation tells the amount of association between two variables; regression describes the relationship between the variables.

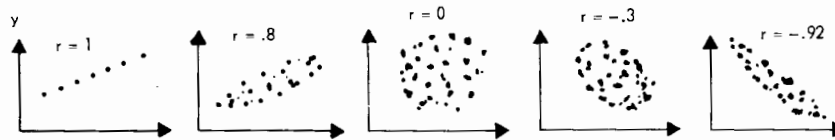

Correlation Coefficient (R)

This is the measure of association between two variables. (See Correlation.)

Curve Fitting

Curve fitting, usually synonymous with regression, is the process of finding the best equation to relate variables.

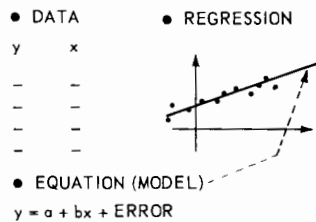

Degrees of Freedom

Degrees of freedom measures the number of independent contributions in deriving estimates.

Dependent Variable

In the equation $y = A + Bx$, y is usually termed the dependent variable while x is the independent variable.

Distribution

There are several classic patterns or distributions of data. These are shown by the drawings at the right.

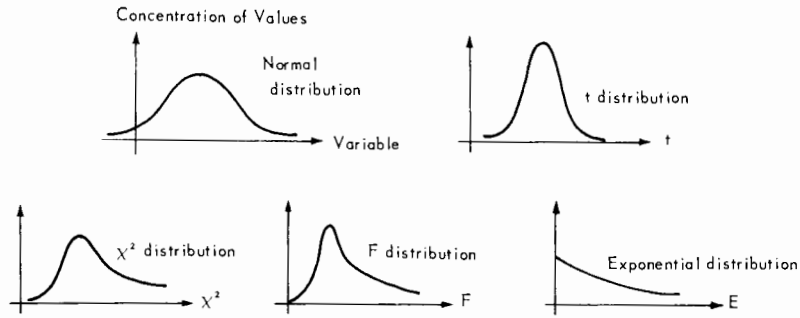

Exponential Curve Fit*

An equation of the form $y = Ae^{Bx}$.

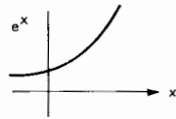

Goodness of Fit

A regression is measured by how close the equation fits the data. The coefficient of determination is one such measure of the goodness of fit.

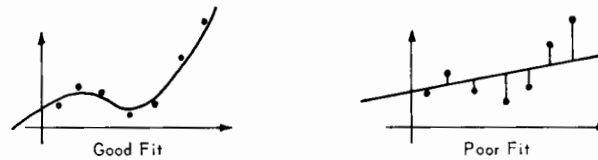

Histogram

A diagram illustrating the distribution of the frequency of occurrence of observations from some population or sample of data points.

Least Squares

Least squares is a mathematical method for finding the best possible equation relating x 's and y . It is the method used by the Model 9805 to derive all regression coefficients.

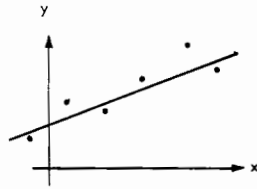

Linear Curve Fit

An equation of the form $y = A + Bx$. The graph of this equation is a straight line.

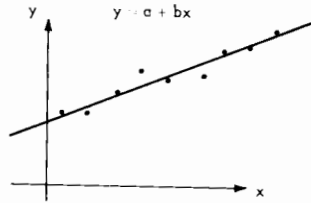

Logarithmic Curve Fit*

An equation of the form: $y = A + B \ln x$.

Mean — see Average

Model

The general form of the equation is termed the model. For example, $y = A + Bx$ is a linear model.

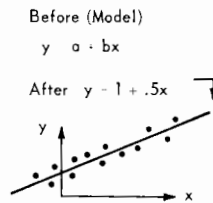

Normal Distribution

One of the classic patterns of data, normal distribution produces a symmetric bell-shaped curve and is prevalent in nature. For example, the heights of men are normally distributed. (See *Distribution*.)

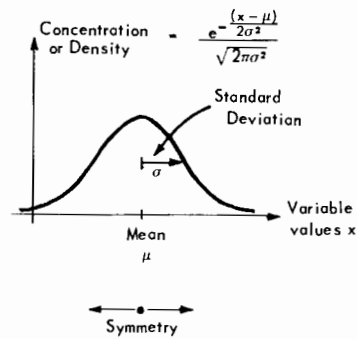

Normal Curve Overlay*

A plot based on the sample *Mean* and *Standard Deviation* of histogrammed data.

Parabolic Curve Fit

An equation of the form $y = A + Bx + Cx^2$.

Power Curve Fit*

An equation of the form $y = Ax^B$

Regression – see Curve Fitting

Residual

The residual is the difference between the actual value of y and the estimate found from the curve fit.

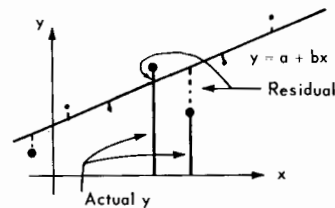

r^2 – see Coefficient of Determination

Slope

The slope is the change in y for a unit increase in x . In the equation $y = A + Bx$, the slope is B .

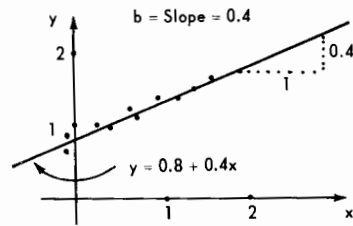

Standard Deviation

Standard deviation measures the scattering of the points about the curve fit. The 9805 calculates the sample standard deviation.

t-Paired

The 9805 calculates t-paired on the differences between pairs of observations. This is a more sensitive test than the two-sample t test. The statistic calculated follows a t distribution with $n-1$ degrees of freedom.

Two-Sample t

This is a hypothesis test to determine the difference, if any, between two populations means. The assumption is that the variances of the two populations are equal. The statistic calculated follows the t distribution with $n_1 + n_2 - 2$ degrees of freedom if the null hypothesis is true.

Variance

Another statistical measure of the scattering of data around the average. It is equal to the square of the *Standard Deviation*.

Operating Notes

- N O T E 00 Internal Program encountered an error - see instructions on restarting the program
- N O T E 04 Too many () keys pressed - parentheses can be nested 5 levels deep
- N O T E 05 Too many) keys pressed
- N O T E 09 Attempt to find the \log_{10} or Ln value of a negative number
- 9.999999999 99R
N O T E 11 RANGE OF CALCULATION EXCEEDED - Also check the current result of the accumulator
- N O T E 12 Attempt to find \log_{10} or Ln of '0'
- N O T E 15 Attempt to raise '0' to a negative power
- N O T E 16 Attempt to divide by '0'
- N O T E 20 Internal Program encountered an error - see instructions on restarting the program
- N O T E 21 Internal Program encountered an error - check peripheral device and interconnecting cables
- N O T E 22) pressed before a number entry - enter number and continue
- N O T E 24 Not enough) keys pressed.

