



HP 9153B and HP 9154B Service Manual Insert

For use in the 3 1/2-Inch Winchester Service Manual

(Part Number 5958-4122)



Hewlett-Packard Company
700 1st Avenue
Greeley, Colorado 80634

Manual Insert Part Number
5958-4162

First Printing: October 1986
Printed in USA

PRINTING HISTORY

New editions are complete revisions of the manual. Update packages, which are issued between editions, contain additional and replacement pages to be merged into the manual by the customer. The date on the title page of the manual changes only when a new edition is published. When an edition is reprinted, all the prior updates to the edition are incorporated. No information is incorporated into a reprinting unless it appears as a prior update. The edition does not change.

Many product updates and fixes do not require manual changes, and conversely, manual corrections may be done without accompanying product changes. Therefore, do not expect a one to one correspondence between product updates and manual updates.

First Edition.....October 1986

The information contained in this document is subject to change without notice.

HEWLETT-PACKARD MAKES NO WARRANTY OF ANY KIND WITH REGARD TO THIS MATERIAL, INCLUDING, BUT NOT LIMITED TO, THE IMPLIED WARRANTIES OF MERCHANTABILITY AND FITNESS FOR A PARTICULAR PURPOSE. Hewlett-Packard shall not be liable for errors contained herein or for incidental or consequential damages in connection with the furnishing, performance, or use of this material.

HP Computer Museum
www.hpmuseum.net

For research and education purposes only.

SAFETY CONSIDERATIONS

SAFETY SYMBOLS



Indicates hazardous voltages.



Indicates earth (ground) terminal.



WARNING

WARNING calls attention to a procedure or practice which, if not correctly performed or adhered to, could result in personal injury. Do not proceed beyond a **WARNING** sign until the indicated conditions are fully understood and met.

CAUTION

CAUTION calls attention to an operating procedure or practice which, if not correctly performed or adhered to, could result in damage to the product or tape medium. Do not proceed beyond a **CAUTION** sign until the indicated conditions are fully understood and met.

SAFETY EARTH GROUND - This is a safety class I product and is provided with a protective earthing terminal. An uninterruptible safety earth ground must be provided from the main power source to the product input wiring terminals, power cord, or supplied power cord set. Whenever it is likely that the protection has been impaired, the product must be made inoperative and be secured against any unintended operation.

BEFORE APPLYING POWER - Verify that the product is configured to match the available main power source. If this product is to be operated with an autotransformer make sure that the common terminal is connected to the earth terminal of the main power source.

PREFACE

This manual provides field service information for the HP 9153B and HP 9154B products.

The information contained in this document enables repair to the printed circuit board level. Information is not supplied for electrical component repair or drive mechanism repair of the 3 1/2-inch Winchester Disc Drive or the other drives which comprise a product.

Each chapter of this document treats a specific service subject. The discussion of this subject for each product (or group of nearly-identical products) is found in a physically separate portion of the chapter denoted by a tab printed on the edge of the paper. A product (or group of products) is found by consulting the first page of the chapter which contains a "pointer" directory.

The contents of this manual are organized in 12 chapters as follows:

- Chapter 1 - Product Description -

• Gives a brief description of the mass memory products using the 3 1/2-inch Winchester disc drive. Specifications, supported options, accessories, and serial number information is included.

Support strategy, as it applies to replaceable parts is described.

- Chapter 2 - Site Preparation and Requirements -

Explains the environmental limits that apply to the drives and any necessary site preparation.

- Chapter 3 - Installation and Configuration -

Describes the installation of the units within the user's system. Pre-installation, installation, configuration, post-installation, and functional verification procedures are described.

- Chapter 4 - Preventive Maintenance -

Describes the procedures necessary to keep the product in an operational state. Explains Hewlett-Packard's preventive maintenance philosophy for specific equipment and any maintenance procedures normally provided by the customer.

- Chapter 5 - Functional Description -

Describes the theory of operation of major functional areas.

- Chapter 6 - Removal and Replacement -

Provides disassembly and assembly information. An exploded view of the unit is also provided which references part numbers that are listed in the replaceable parts section.

PREFACE (continued)

- Chapter 7 - Adjustments -

Describes the setup necessary to perform any adjustments and what conditions may cause the need for these adjustments.

- Chapter 8 - Troubleshooting and Diagnostics -

Defines the available selftest capabilities of the products, the results of running the individual on-board tests, and the order in which on-board tests must be run.

- Chapter 9 - Replaceable Parts -

Lists all orderable parts.

Orderable parts, in reference to the products in this chapter, means field-replaceable assemblies. In addition, a listing of component parts of these field replaceable assemblies is also provided.

- Chapter 10 - Reference -

Lists all documentation material needed to support this manual. This includes non-HP host documentation that is involved in the troubleshooting and configuration of these drives.

- Chapter 12 - Diagrams -

No additional diagrams are needed for service.

CONTENTS

	Page
Printing History	i
Safety Considerations	ii
Preface	iii
Contents	v
Illustrations	viii

PRODUCTS

- HP 9153B
- HP 9154B

CHAPTER 1 PRODUCT INFORMATION

[1] PRODUCT DESCRIPTION	1-3
[2] EQUIPMENT SUPPLIED	1-3
[3] SPECIFICATIONS	
Interface	1-4
Performance Characteristics	1-4
[4] SERIAL NUMBER INFORMATION	1-5
[5] TEST EQUIPMENT AND SPECIAL TOOLS	1-5
[6] SUPPORT STRATEGY	1-6

CHAPTER 2 SITE PREPARATION AND REQUIREMENTS

[1] SITE PREPARATION	2-3
[2] ENVIRONMENTAL REQUIREMENTS	
Environmental Ranges	2-3
Physical Characteristics	2-4
Power Requirements	2-4
[3] RESTRICTIONS	
HP-IB Interface Restrictions	2-4

CHAPTER 3 INSTALLATION AND CONFIGURATION

[1] INSTALLATION	
Voltage Selection and Fusing	3-3
[2] CONFIGURATION OF STANDARD DRIVE UNIT	
Configuration Switches	3-4
HP-IB Address Switches	3-5
Selecting the HP-IB Address	3-6
Volume Configuration Switch	3-6

CONTENTS (continued)



	Page
[3] SELFTESTS DURING POWER-UP	3-7
[4] USER INFORMATION AND OPERATION	
Write Protect Error On Initialization (HP 9153B)	3-7
Disc Compatibility (HP 9153B)	3-7
System Support	3-8
CHAPTER 4 PREVENTIVE MAINTENANCE	
[1] PREVENTIVE MAINTENANCE PROCEDURES	4-3
CHAPTER 5 FUNCTIONAL DESCRIPTION	
[1] INTRODUCTION	5-3
[2] BLOCK DIAGRAM	
HP-IB Interface.	5-3
Clocks and Resets.	5-3
Microcontroller	5-4
Input and Output Ports	5-4
PLL's and Drive Interface	5-9
CHAPTER 6 REMOVAL AND REPLACEMENT	
[1] INTRODUCTION	6-3
[2] TOP COVER REMOVAL.	6-3
[3] CONTROLLER PCA REMOVAL.	6-3
[4] POWER SUPPLY REMOVAL.	6-4
[5] DRIVE REMOVAL	6-4
CHAPTER 7 ADJUSTMENTS.	7-1
CHAPTER 8 TROUBLESHOOTING AND DIAGNOSTICS	
[1] REPAIR PHILOSOPHY	8-3
[2] PREPARATION FOR TROUBLESHOOTING.	8-3
[3] POWER SUPPLY ASSEMBLY.	8-3
[4] SELFTESTS	
Test Performed During Power-on	8-5
Fault LED Indications During Power-on	8-6
Execution Of Service Selftests	8-7
Fault LED Indications During Execution of Service Selftests	8-8
Service Selftests Available	8-8

CONTENTS (continued)

	Page
[5] TROUBLESHOOTING PROCEDURES	
General Information	8-9
Troubleshooting Flowchart	8-10
Procedures P0 Through P4	8-11
Repair Verification	8-13
The SS/80 Exerciser	8-14
[6] CONNECTOR PIN DEFINITIONS	8-16
 CHAPTER 9 REPLACEABLE PARTS	
[1] INTRODUCTION	9-3
 CHAPTER 10 REFERENCE	
[1] MANUAL REFERENCES	10-3
 CHAPTER 11 PRODUCT HISTORY	
[1] HISTORY	11-3
 CHAPTER 12 DIAGRAMS	12-1

ILLUSTRATIONS

PRODUCTS

- HP 9153B
 - HP 9154B
-

Figure	Page
CHAPTER 1	
1-1 HP 9153B and HP 9154B (Front View)	1-3
CHAPTER 3	
3-1 HP 9153B and HP 9154B Rear Panel	3-4
3-3 Controller Configuration Switch (SW3)	3-6
3-5 Volume Configuration Switch	3-7
CHAPTER 5	
5-1 Read Port Definitions	5-5
5-2 Drive Configuration Switch Definitions.	5-6
5-3 Write Port Definitions.	5-7
5-4 HP 9153/54B Block Diagram	5-9
CHAPTER 6	
6-1 HP 9153/54B Power Supply	6-5
6-2 Controller PCA	6-6
6-3 HP 9153B/HP 9154B Drive Configuration.	6-7
CHAPTER 8	
8-1 Power Supply PCA	8-4
8-2 Front Panel Control and Indicators.	8-4
8-3 Troubleshooting Flowchart	8-10
8-4 HP 9153B/HP9154B Drive Configurations.	8-14
8-5 Cable Interconnect	8-16
8-6 Drive Configuration Switch	8-16
8-7 Rear View of HP 9153/54B	8-17
CHAPTER 9	
9-1 HP 9153B Exploded View.	9-7

CONTENTS (continued)

This page intentionally left blank.

PRODUCT INFORMATION

CHAPTER

1



This chapter gives a brief description of the mass memory products using the 3 1/2-inch Winchester disc drive. Specifications, supported options, accessories, and serial number information are included.

Support strategy, as it applies to replaceable parts is described.

Single products and groups of products that use the 3 1/2-inch Winchester drive are found by referring to the tab on the right side of the page in this chapter.



[1] PRODUCT DESCRIPTION

The HP 9153B/9154B Disc Drives (Figure 1-1) are random access data storage devices. The HP 9153B contains a single 3 1/2-inch double-sided slimline flexible disc drive providing 710 Kbytes (at 512 bytes/sector) of storage capacity and a 3 1/2-inch Winchester disc drive which provides 20 Mbytes of storage capacity. The HP9154B contains a 3 1/2-inch Winchester disc drive but not a flexible disc drive.

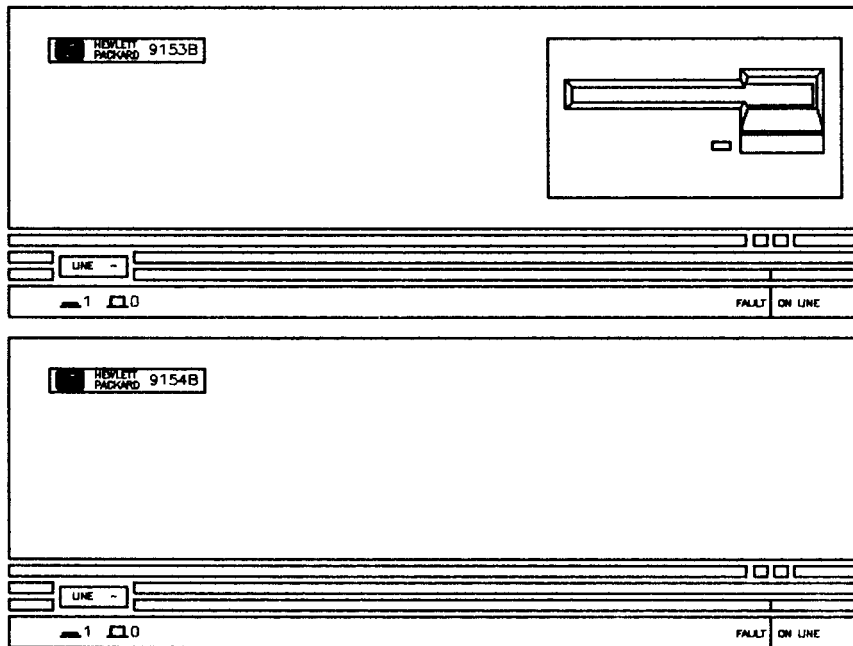

9153B
9154B

Figure 1-1. HP 9153B and HP 9154B (Front View)

[2] EQUIPMENT SUPPLIED

Description	Quantity	HP Part Number
Power cord	1	Dependent on location
Fuse	1	(Europe) 2110-0673 (1.5AMP, 250 VAC)
	1	2110-0003 (3.0AMP, 250 VAC)
Operator's Manual	1	09153-90005
Shipping Disc	1	1535-4881
Rubber Wedge	1	9223-0648

Order a package of ten flexible 3 1/2-inch discs using HP part number 92191A.

PRODUCT INFORMATION

[3] SPECIFICATIONS

INTERFACE

IEEE 488-1978 (HP-IB)

PERFORMANCE CHARACTERISTICS

3 1/2-inch Flexible Disc Drive

9153B
9154B

256 Byte Sectors

Item	Data Bytes Per	Sectors Per	Tracks Per	Heads Per
Sector	256			
Track	4096	16		
Head	315392	1232	77	
HP 9153B	630784	2464	154	2

512 Byte Sectors

	Data Bytes Per	Sectors Per	Tracks Per	Heads Per
Sector	512			
Track	4608	9		
Head	354816	693	77	
HP 9153B	709632	1386	154	2

1024 Byte Sectors

	Data Bytes Per	Sectors Per	Tracks Per	Heads Per
Sector	1024			
Track	5120	5		
Head	394240	385	77	
HP 9153B	788480	770	154	2

Single-sided Format

	Data Bytes Per	Sectors Per	Tracks Per	Heads Per
Sector	256			
Track	4096	16		
Head	270336	1056	66	
HP 9153B	270336	1056	66	1

Recording Format MFM

Max Sustained Transfer Rate* 17K Bytes/s

Average Access Time 175 ms

Rotational Speed 600 rpm

* Mainframe dependent. This is the maximum measured rate for long transfers.

3 1/2-inch Winchester Disc Drive

Item	Data Bytes Per	Sectors Per	Tracks Per	Heads Per
Sector	256			
Track	7168	28		
Head	10035200	39200	1400	
HP 9153B	20070400	78400	2800	2

9153B
9154B

Recording Format MFM

Max Sustained
Transfer Rate* 174K Bytes/s

Average Access Time 75 ms

Rotational Speed 3000 rpm

* Mainframe dependent. This is the maximum measured rate for long transfers.

[4] SERIAL NUMBER INFORMATION

This manual applies to HP 9153B units having serial numbers prefixed by 2633A and HP 9154B units having serial numbers prefixed by 2634A. Drives with later prefix numbers will be covered in manual updating supplements.

[5] TEST EQUIPMENT AND SPECIAL TOOLS

7mm Nutdriver (HP part number 8710-1217)
 #1 Pozidriv screwdriver (HP part number 8710-0899)
 #2 Pozidriv screwdriver (HP part number 8710-0900)
 Needlenose pliers
 Multimeter

HP85 Service System
 SS/80 Exerciser (HP part number 5010-0310)
 SS/80 Exerciser document (HP part number 5958-4142)
 Subset/80 Reference Manual (HP part number 5958-4129)

PRODUCT INFORMATION

[6] SUPPORT STRATEGY

The support strategy for the 9153B and 9154B is to the designated field-replaceable assembly level. Following are the replaceable assemblies:

EXCHANGE ASSEMBLIES

HP PART NUMBER

3 1/2-inch disc drive

09123-69101

Controller PCA

09153-69510

3 1/2-inch Winchester disc drive

45816-69111

NON-EXCHANGE ASSEMBLIES

Power Supply

09153-67110

9153B
9154B

SITE PREPARATION AND REQUIREMENTS

CHAPTER

2



This chapter explains the environmental limits that apply to the drives and any necessary site preparation.

Single products and groups of products that use the 3 1/2-inch Winchester drive are found by referring to the tab on the right side of the page in this chapter.

[1] SITE PREPARATION

The following information covers the requirements for proper operation of the HP 9153B/9154B disc drive. Site preparation is normally a customer responsibility.

[2] ENVIRONMENTAL REQUIREMENTS



9153B
9154B

ENVIRONMENTAL RANGES

	9153B	9154B
Temperature		
Operating	10 to 40 degrees C (50 to 104 degrees F)	0 to 40 degrees C (32 to 104 degrees F)
Non-Operating	-40 to 60 degrees C (-40 to 140 degrees F)	-40 to 60 degrees C (-40 to 140 degrees F)

Humidity (HP 9153/HP 9154)

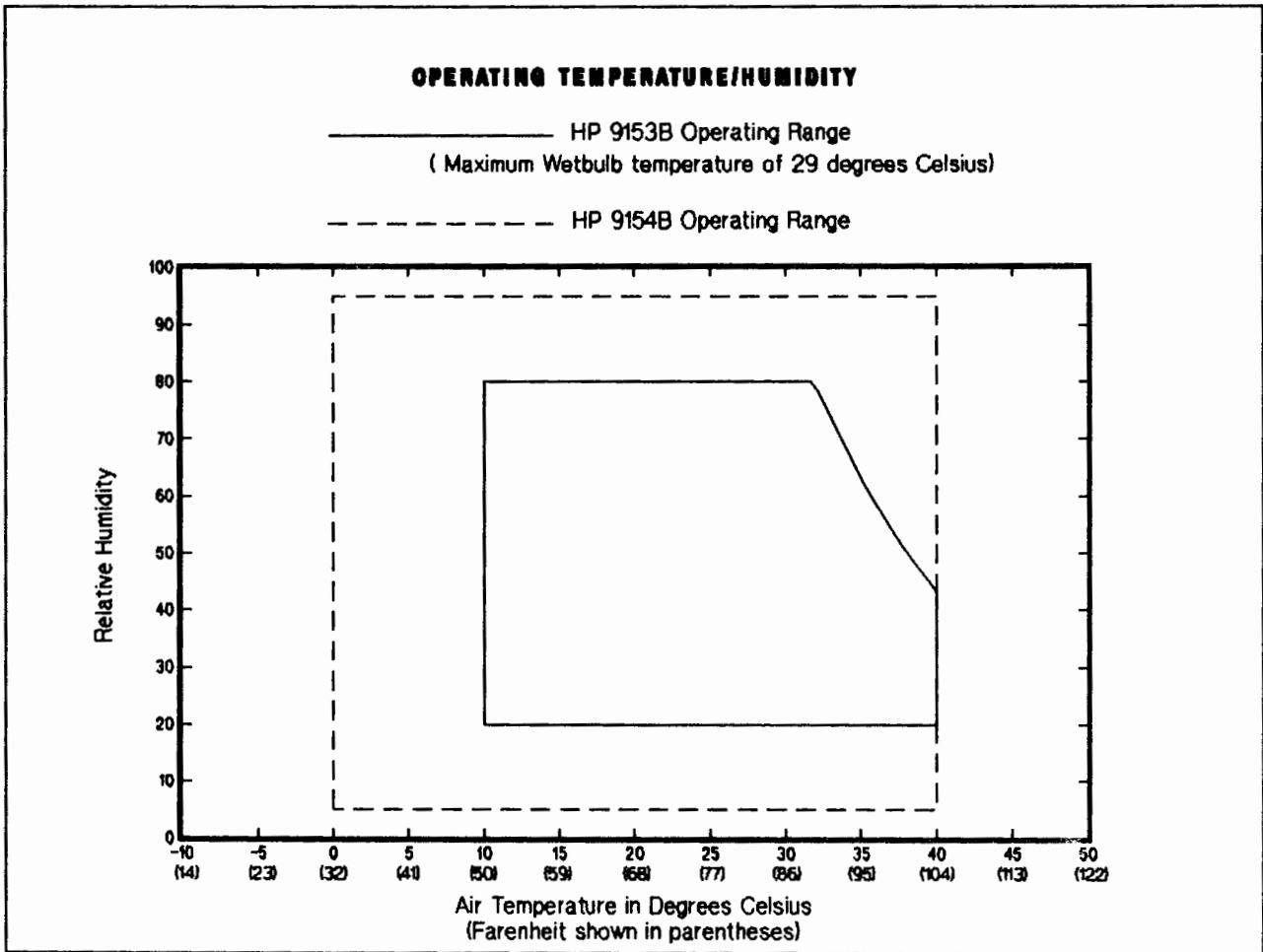

SITE PREPARATION AND REQUIREMENTS

	9153B	9154B
Altitude		
Operating	0 to 4572m (0 to 15000 ft)	0 to 4572m (0 to 15000 ft)
Non-Operating	-304 to 15240m (-1000 to 50000 ft)	-304 to 15240m (-1000 to 50000ft)

9153B
9154B

PHYSICAL CHARACTERISTICS

Size		
Height	106 mm (4.2 in)	
Width	325 mm (12.8 in)	
Depth	285 mm (11.2 in)	
Weight		
Net	7.7 kg (16.2 lbs)	6.8 kg (14.9 lbs)
Shipping	9.4 kg (20.8 lbs)	8.9 kg (19.5 lbs)

POWER REQUIREMENTS

	9153B	9154B
Voltage	86-127VAC (115V setting)	86-127VAC
(selected by rear panel switch)	195-253VAC (230V setting)	195-253VAC
Frequency	48-66 Hz	48-66Hz
Power	50W max 30W typical	50W max 30W typical

NOTE

The flexible disc drive in the HP 9153B is designed for operation in a typical office environment. Use of the equipment in an environment containing dirt, dust, or corrosive substances will cause the flexible disc and disc drive life to be drastically reduced.

[3] RESTRICTIONS

HP-IB INTERFACE RESTRICTIONS

1. All AC line switches on the disc drives and computing system must be turned "OFF" when connecting and disconnecting disc drives.
2. The total length of cable permitted in one bus system must be less than or equal to two metres times the number of devices connected together (the interface card is considered one device).
3. The total length of the cable must not exceed 20 metres. For example, a system containing six devices can be connected together with cables that have a total length less than or equal to 12 metres (six devices x 2m/device = 12 metres). The individual lengths of cable may be distributed in any manner desired as long as the total length does not exceed the allowed maximum. If more than 10 devices are to be connected together, cables shorter than two metres must be used between some of the devices to keep the total cable length less than 20 metres.
4. The maximum number of devices that can be connected together in one bus system is 15.

There are no restrictions to the way cables may be connected together; however, it is recommended that no more than four piggyback connectors be stacked together on one device. The resulting structure could exert enough force on the connector mounting to damage it.

9153B
9154B



SITE PREPARATION AND REQUIREMENTS

**9153B
9154B**



This page intentionally left blank.

INSTALLATION AND CONFIGURATION

CHAPTER

3

This chapter describes the installation of the units within the user's system. Pre-installation, installation, configuration, post-installation, and functional verification procedures are described.

Single products and groups of products that use the 3 1/2-inch Winchester drive are found by referring to the tab on the right side of the page in this chapter.



[1] INSTALLATION

VOLTAGE SELECTION AND FUSING

The voltage select switch on the rear panel must be set to the nominal line voltage for the area in which the disc drive is to be operated. Figure 3-1 shows the voltage select switch set for 115 VAC line voltage.

CAUTION

Always turn the AC power switch off or disconnect the AC line cord before changing the line voltage select switch position. Changing the line voltage select switch setting while AC power is on could damage the unit.

9153B
9154B

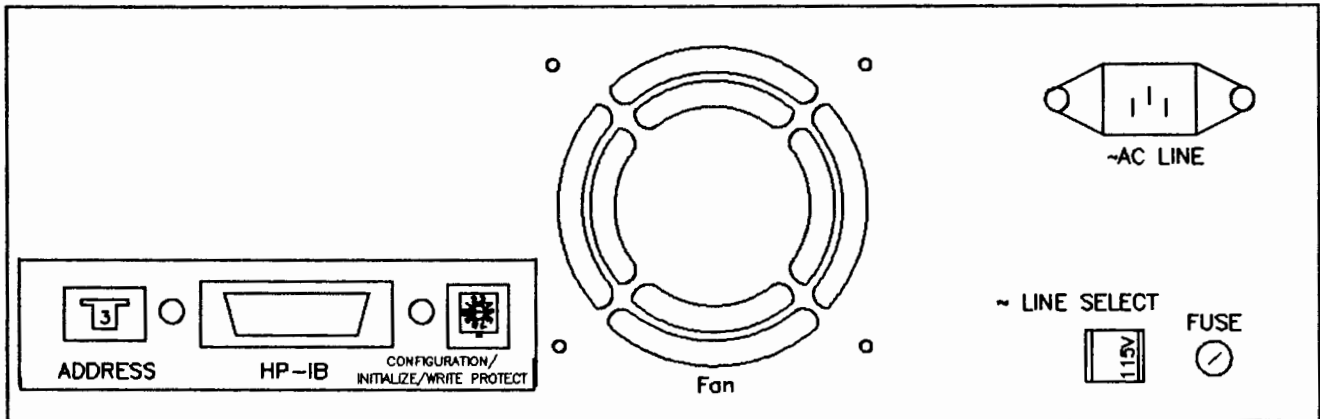

Figure 3-1. HP 9153B and HP 9154B Rear Panel.

A different fuse is required for each of the two voltage ranges of 110-120 and 220-240 VAC. Figure 3-2 gives the correct fuse ratings and part numbers. The fuse included in the HP 9153B/54B depends upon where the equipment is to be delivered.

Setting	Voltage Range	Fuse Rating	HP Part Number
115 VAC	86-127 VAC	3.0 Amp 250 vac-normal blow	2110-0003
230 VAC	195-253 VAC	1.5 Amp 250 vac-normal blow	2110-0673

Figure 3-2. Fuses.

WARNING

ALWAYS DISCONNECT THE DISC DRIVE FROM ANY AC LINE BEFORE CHANGING FUSES.

INSTALLATION AND CONFIGURATION

The 9153B/54B disc drives are connected to the computer or computing system using one of the HP-IB cables listed in Figure 3-3. Refer to the host operators manual for system-specific installation procedures.

Length	HP-IB Accessory Number
0.5 metre	10833D
1 metre	10833A
2 metres	10833B
4 metres	10833C

Figure 3-3. HP-IB Cables.

CAUTION

Flexible disc drive performance and reliability are dependent on the type of media used. Disc drive specifications can be assured only when using HP media. The use of improper media can result in premature disc failure or damage to the disc drive.

Never turn the disc drive off or remove the disc from the flexible disc drive when its ACCESS LED or when the ON LINE LED is on; doing so can cause loss of data.

[2] CONFIGURATION OF STANDARD DRIVE UNIT

CONFIGURATION SWITCHES

Switch bank SW3, located on the Controller PCA near the HP-IB connector, is used to configure the unit and initiate the selftest routines. The following figures show the location of SW3 and the different configurations available.

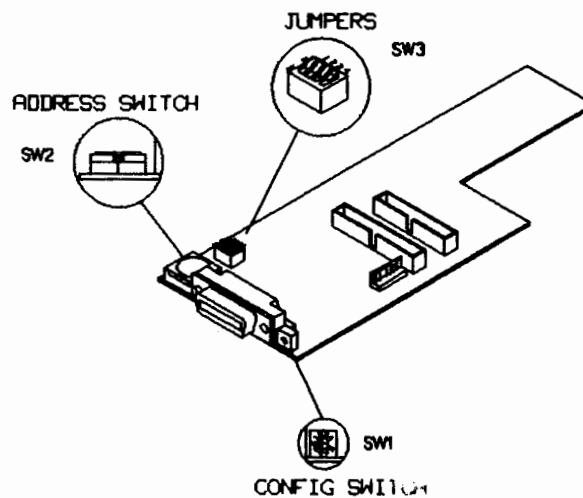

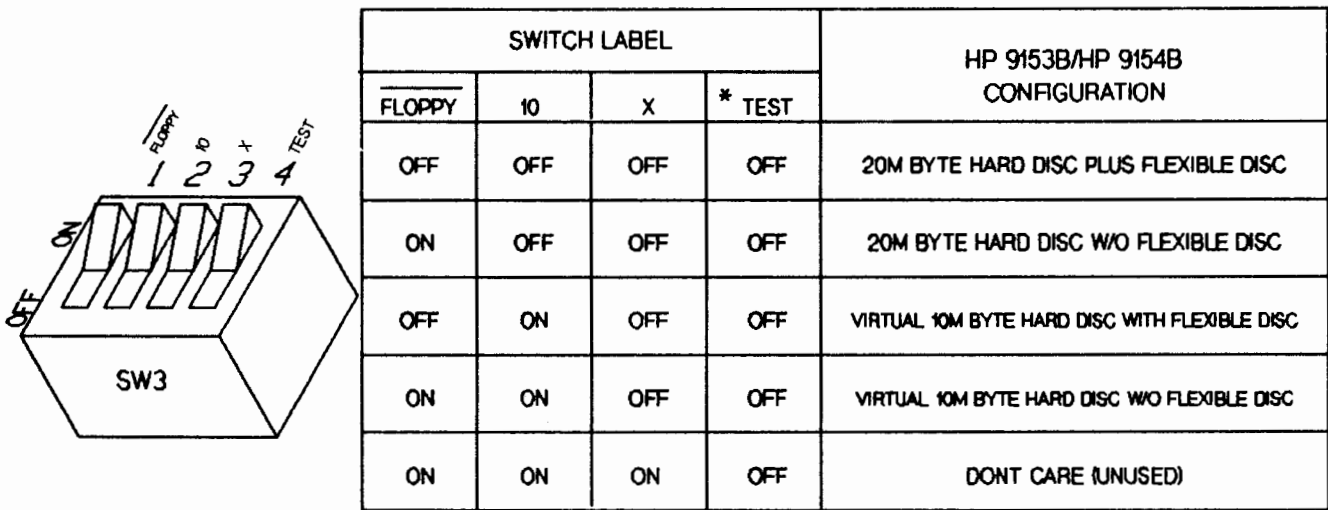

9153B
9154B

* Used to initiate service selftest routines. Refer to Chapter 8 for further information.

Figure 3-4. Controller Configuration Switch SW3.

HP-IB ADDRESS SWITCH

The HP-IB address switch (see Figure 3-1) is a rotary switch with decimal numbers. This switch setting has the following meanings:

- HP-IB switch = 0 through 7 HP-IB address of device is the same as the switch setting.
- Hard disc = unit 0
Floppy = unit 1
- HP-IB switch = 8 or 9 HP-IB address of the device is 0.
- Hard disc = unit 1
Floppy = unit 0

The HP-IB switch is being used for more than just the HP-IB address of the device. It is being used to designate whether the flexible disc drive is Unit 0 or Unit 1. Note that the actual HP-IB addresses are still numbers from 0 through 7. Addresses 8 and 9 are the same as address 0; however in these positions the 3 1/2-inch flexible disc drive is at Unit 0.

SELECTING THE HP-IB ADDRESS

To select an HP-IB address, locate the thumbwheel switch on the back of the unit (See Figure 3-1). Turn the thumbwheel switch until the address you want appears in the window. Refer to your system operator's manual for proper setting of the HP 9153B/54B address within the system.

VOLUME CONFIGURATION SWITCH

Volume selection is accomplished by switch SW1 located to the right of the HP-IB connector at the rear of the unit (see Figure 3-1). The switch allows the user to divide the Winchester disc into multiple volumes. These volumes can be formatted independently with different interleaves and can have different file systems on them. To use this feature, the host must support multiple volumes. If the host supports only a single volume, volume 0, then this feature is of no use and should be set to the one volume setting. The settings on the volume switch have the following meanings:

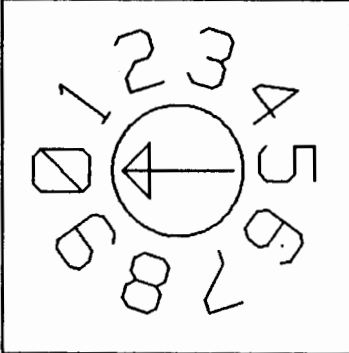

SETTING	NUMBER OF VOLUMES	VOLUME SIZES (MB/VOL)					
0	Allows re-initializing of existing volumes. At first, if you leave the switch at the factory setting of 0, the hard disc is initialized as one volume (it defaults to setting 1).						
1	One	20.12					
2	Two	10.06			10.06		
3	Three	3.01	3.01	14.1			
4	Four	5.03	5.03	5.03	5.03		
5	Two	5.03	15.09				
6	Six	3.35	3.35	3.35	3.35	3.35	3.35
7	Two	3.01	17.11				
8	Prevents writing to the first volume of the hard disc. Prevents accidental re-initializing of the hard disc.						
9	Prevents accidental re-initializing of the hard disc.						

Figure 3-5. Volume Configuration Switch.

NOTE

To change the volume switches, first turn off the power, and select the kind of divisions you want. Then turn the power back on. In order to write directories, reformat any volumes you are going to use. All old data will be lost when you format the volume.

[3] SELFTESTS DURING POWER-UP

At power-on, a sequence of selftests checks the processor, ROM, HP-IB IC, processor RAM, buffer RAM, and the drive(s). The Winchester disc test reads and writes sectors, checks the spindle speed, and checks that the ECC logic functions correctly. The FAULT LED, if it remains on after the power-on selftest, indicates a problem was encountered in the selftests.

When the HP 9153B or HP 9154B is first powered-on, the FAULT and ON LINE LED will come on. The ON LINE LED goes off and the flexible disc drive ON LINE LED comes on when testing of the flexible disc begins (9153B only). The FAULT LED remains on until the power-on selftests are complete. All tests are performed in unit number order; i.e., if the address is 8 or 9, then the flexible disc drive is tested first.

9153B
9154B

If the flexible disc drive ON LINE LED goes off and the FAULT LED remains on continuously or is flashing, refer to Chapter 8, Troubleshooting and Diagnostics, for a full explanation of these error codes and what and how to correct the fault.

NOTE

If a new Winchester disc drive has just been installed, the FAULT LED will remain on until the drive has been formatted and the unit has been power cycled.

[4] USER INFORMATION AND OPERATION

WRITE PROTECT ERROR ON INITIALIZATION (HP 9153B)

A motor speed check is performed before initializing a flexible disc. If the motor speed is outside of the allowed tolerance, a Write Protect Error is generated preventing disc drive initialization. If the drive is operating properly, this indicates a defective flexible disc. Discard the disc.

DISC COMPATIBILITY (9153B)

The following table shows the recommended usage of single-sided and double-sided flexible discs with the HP 9153B. Words used in the table are defined as follows:

* "Exchange only" means that the disc should be used only for exchanging data and programs with single-sided disc drives, and should not be used on a daily basis.

* "OK" means that the disc may be used on a daily basis.

Single-sided HP disc	Exchange only
Double-sided HP media in single-sided format	OK
Double-sided HP media in double-sided format	OK
HP software	OK

INSTALLATION AND CONFIGURATION

SYSTEM SUPPORT

The following information shows the major host systems that support the HP 9153/54B drives.

HP 9000 Series 200, 300

Series 200

Boot ROM 3.0 or later
Basic 3.0 or later
Pascal 3.0 or later
HP-UX 2.0 or later

Series 300

Boot ROM Rev A or later
Basic 4.0 or later
Pascal 3.1 or later
HP-UX 5.0 or later

For more information on the 9000 system, refer to the Peripheral Installation Guide for HP 9000, Series 200/300 Computer (Part number 97005-90000).

HP Touchscreen II PC

Supported by the standard operating system.

HP 150 and HP Touchscreen PC

Upgrade Kit, part number 45849-63006, must be installed.

Instructions for using the HP 9153/54B with Series 200/300, HP Touchscreen II PC, and the HP Integral PC are provided in the "Getting Started with Your HP 9153/HP 9154 Disc Drive" operator manual (Part number 09153-90005).

PREVENTIVE MAINTENANCE

CHAPTER

4

This chapter describes the procedures necessary to keep the product in an operational state. It explains Hewlett-Packard's preventive maintenance philosophy for specific equipment and any maintenance procedures normally performed by the customer.

Single products and groups of products that use the 3 1/2-inch Winchester drive are found by referring to the tab on the right side of the page in this chapter.

[1] PREVENTIVE MAINTENANCE PROCEDURES

The Winchester disc drive in the HP 9153B/9154B does not require preventive maintenance.

The flexible disc drive in the HP 9153B also does not require preventive maintenance. However, if excessive read errors occur, the head may be cleaned using a head cleaning disc available from HP (part number 09122-89415). This disc must be used in accordance with the SS/80 Exerciser program. Do not use the head cleaning disc routinely because repetitive use of the cleaning disc may accelerate head wear. In order to clean the heads, it will be necessary to use the SS/80 Exerciser program with the HP 85 Service System.

9153B
9154B



FUNCTIONAL DESCRIPTION

CHAPTER

5

This chapter gives the theory of operation of major functional areas.

Single products and groups of products that use the 3 1/2-inch Winchester drive are found by referring to the tab on the right side of the page in this chapter.



[1] INTRODUCTION

A host computer is connected to the HP 9153B/HP 9154B via the HP-IB connector. The protocol used in communicating between the host and the HP 9153B/HP 9154B is the Subset 80 protocol. The various commands for this protocol will not be discussed here but can be found in the SS/80 Reference Manual P/N 5958-4129.

The function of the controller is to execute SS/80 commands. This includes such things as handling error detection and correction, formatting, sparing of bad areas, monitoring disc wear, and performing selftests.

9153B
9154B

[2] BLOCK DIAGRAM

The controller is built around the Disc Controller IC. Interfacing to the Disc Controller are the: HP-IB controller, Buffer RAM, Microcomputer and I/O ports, PLL and the drive mechanisms. There are two address and data busses on this product. One set is dedicated to the Microcomputer and I/O ports while the other set is dedicated to the HP-IB interface and Buffer RAM. They are separated by the disc controller.

The Disc Controller provides the flexible disc, Winchester disc and DMA controller, interfacing to the HP-IB controller and address decoding and cycle stretching for the microprocessor.

There are five major blocks on this board: the HP-IB interface including the Buffer RAM, the Microcontroller, the input and output Ports, and the Phase Locked Loops. In the following discussion, please refer to the block diagram in Figure 5-4.

HP-IB INTERFACE

The HP-IB interface is made up of the Disc Controller Interface, the HP-IB Controller and HP-IB Transceivers, and Buffer RAM sharing a common data bus.

The Disc Controller allows the Microcontroller to write commands directly to the the HP-IB Controller to set up its various control registers. IOA2-IOA0 provide the register addressing.

The Disc Controller uses the data bus; which is common between the Buffer RAM, Disc Controller and the HP-IB Controller; to provide DMA between the disc drive and RAM, the HP-IB Controller and RAM or Microcontroller and RAM. The Disc Controller provides the addressing for all of the DMA channels; therefore, the address bus is connected to the Disc Controller and Buffer RAM. The chip selects and timing signals are all provided by the Disc Controller.

CLOCKS AND RESETS

The system clock is generated by a 40MHz crystal which the disc controller divides into 8MHz for the microprocessor and 4MHz for the 3 1/2-inch Winchester mechanism.

Two reset lines have been implemented. The power supply provides a PVAL signal unasserted at power-on. During brown outs, the signal is re-asserted 100 milliseconds after the power supply output voltages become stable. This is the reset for the Disc Controller. The other reset is designed to follow PVAL when it goes low, but adds a few microseconds delay before re-asserting PVAL. This delayed reset goes to the rest of the controller board.

FUNCTIONAL DESCRIPTION

The 100ms reset is provided to enable the oscillator to stabilize before using it to clock the Disc Controller. The following 20 microsecond delay is provided to enable the Disc Controller clock outputs to stabilize before using them to clock the rest of the controller PCA logic.

MICROCONTROLLER

The Microprocessor, 32Kx8 EPROM, 16Kx8 EPROM and 8Kx8 RAM form the Microcontroller hardware. The high order address lines A15-A12 and the E and Q clocks go to the Disc Controller which performs the address decoding and generates the chip selects and timing for the EPROM, RAM and I/O Ports. The addresses are decoded then ANDed with E+Q to prevent erroneous pulses. The low address lines A1-4 also go to the Disc Controller and are used to address its internal registers.

INPUT AND OUTPUT PORTS

Address decoding begins with the EXT_RD and EXT_WR pins from the Disc Controller . These lines are active when the processor is accessing between 2000 and 2FFF. They include the appropriate timing based on the E and Q clock. U21 decodes the these lines, with A10 and A11, and uses them as buffer enables and output latch clocks for Ports 0-2.

Two buffers provide the input ports for the HP-IB address switch, Volume Configuration switch, Drive Configuration switch and flexible disc drive status. Registers provide the output ports to the flexible disc drive, 3 1/2-inch Winchester control lines and the two front panel LED's. A Read or Write to Register 0 is an access to the 3 1/2-inch Winchester drive.

Following is a brief discussion of Read Ports 0 through 2. Read Port 0 is used by the 3 1/2-inch Winchester disc drives analog-to-digital converter and no further discussion will be given on this port. Figure 5-1 and the following text explains the meaning of data bits D0 through D7 for Read Ports 1 and 2.

READ PORTS (1 and 2)								
DATA BITS								
	D7	D6	D5	D4	D3	D2	D1	D0
RP1	VOLUME CONFIGURATION SWITCH				HP-IB ADDRESS SWITCH			
RP2	FLEX DISC DRIVE DISC CHANGE 3 1/2-Inch Winch. FAULT	FLEX DISC DRIVE READY	FLEX DISC DRIVE TRACK 0	FLEX DISC DRIVE WRITE PROTECT	SELFTEST	DRIVE CONFIGURATION SWITCH SW3 (SEE FIGURE 5-2)		

Hex Address for Read Ports

- Read Port 0 (RP0) 2080-20FF, 2180-21FF, 2280-22FF, 2380-23FF
- Read Port 1 (RP1) 2400-247F
- Read Port 2 (RP2) 2800-287F, 2900-297F, 2A00-2A7F, 2B00-2B7F

Figure 5-1. Read Port definitions.

9153B
9154B

RP1 (Read Port 1)

The HP-IB address switch is a thumbwheel with settings 0-9. The value on the switch is binary encoded into the above data lines. The number is represented in negative true logic, i.e., 6 is 1001.

The Volume Configuration Switch is a dial with settings 0-9. The values are also binary encoded and represented in positive true logic.

RP2 (Read Port 2)

9153B
9154B

Disc Change - This input from the flexible disc drive is low at power-on and whenever the disc is removed from the drive. The line remains true until a disc is installed and a STEP pulse or the DISK CHANGE RESET line is low.

Ready- This input from the flexible disc drive is low when the drive is selected and a disk is inserted and the Index pulse period is stable within 100ms ± 2.5ms.

Track 0- This input from the flexible disc drive is low when the read/write head is positioned on track 0 or outside of track 0.

Write Protect - This input from the flexible disc drive is low when the write protect tab on the flexible disc indicates that the flexible disc is protected.

Selftest - Data bit 3 is a zero when the user has selected the board selftest mode by setting the rocker switch labeled TEST to the ON position.

The Drive Configuration switch bank is labeled SW3 on the controller PCA. If a switch is set to on, the bit is zero. The switch selects drive configurations based on the following codes:

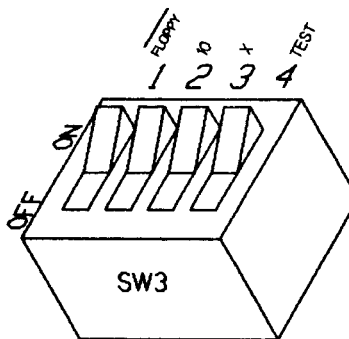

SWITCH LABEL				HP 9153B/HP 9154B CONFIGURATION
FLOPPY	10	X	* TEST	
OFF	OFF	OFF	OFF	20M BYTE HARD DISC PLUS FLEXIBLE DISC
ON	OFF	OFF	OFF	20M BYTE HARD DISC W/O FLEXIBLE DISC
OFF	ON	OFF	OFF	VIRTUAL 10M BYTE HARD DISC WITH FLEXIBLE DISC
ON	ON	OFF	OFF	VIRTUAL 10M BYTE HARD DISC W/O FLEXIBLE DISC
ON	ON	ON	OFF	DONT CARE (UNUSED)

* Used to initiate service selftest routines.

Figure 5-2. Drive configuration switch definitions.

FUNCTIONAL DESCRIPTION

In the following discussion, we will discuss the Write Ports. Write Port 0 is used for the stepper motor on the 3 1/2-inch Winchester disc drive and no further discussion will be given on this port.

Figure 5-3 and the following text will explain the meaning of data bits D0 through D7 for Write Ports 1 and 2.

WRITE PORTS (1 and 2) DATA BITS								
	D7	D6	D5	D4	D3	D2	D1	D0
WP1	3 1/2-inch WINCH ACCESS LED	Not used	3 1/2-inch WINCH FAULT LED	3 1/2-inch WINCH DRIVE SELECT	FLEX DISC DRIVE SELECT 3	FLEX DISC DRIVE SELECT 2	FLEX DISC DRIVE SELECT 1	FLEX DISC DRIVE SELECT 0
WP2	Flexible disc drive Motor On	Flexible disc drive Head Select	Flexible disc drive Head Load	FLEX DISC DRIVE STEP	FLEX DISC DRIVE DIRECTION SELECT	FLEX DISC DRIVE CHANGE RESET	NOT USED	NOT USED

Hex address for Write Ports

Write Port 0 (WP0) 2080-20FF
 Write Port 1 (WP1) 2400-247F, 2500-257F, 2600-267F, 2700-277F
 Write Port 2 (WP2) 2800-2BFF

Figure 5-3. Write Port definitions.

WP1 (Write Port 1)

- D7 Access LED - A zero on this bit illuminates the Access LED on the front panel of the flexible disc drive.
- D5 Fault LED - A zero on this bit illuminates the FAULT LED.
- D4 Drive Select NH - When this bit is a zero, it enables the Sector Signal from the 3 1/2-inch Winchester drive. This line must be enabled when using a 3 1/2-inch Winchester drive and disabled when using a flexible disc drive.
- D3 Drive Select 3 - Floppy - When this bit is zero, the flexible disc drive is being accessed.
- D0 Drive Select 0 - When this bit is a zero, it selects the 3 1/2-inch Winchester drive.

WP2 (Write Port 2)

- D7 Motor On - When the drive is selected and a negative edge occurs on this line, the Motor On signal internal to the drive is set. Likewise, when the drive is selected and a positive edge occurs, the internal status is cleared. This internal Motor-on signal does not change when the drive is not selected. If the internal signal is set, whenever a flexible disc is installed the flexible disc drive spindle motor will turn.

- D6 Head Select - This bit selects which side of the flexible disc is being accessed. A low signal on this line selects the upper (Head 1) side of the flexible disc.
- D4 Step-Floppy - When this signal is a low pulse, the flexible disc drive head is stepped one track.
- D3 Direction Select - When this bit is a zero and the drive is stepped, it will step toward the center track and vica versa.
- D2 Disc Change Reset - When this bit is taken low and then back high while a flexible disc is installed, it clears the flexible disc drive Change Signal.

9153B
9154B

PHASE-LOCK-LOOP's AND DRIVE INTERFACE

The 3 1/2-inch Winchester and flexible disc drives are interfaced to the Disc Controller through two buffers and two PLLs. The Drive Signals: Sector, Fault, Index, 4 MHz clock, Write Gate, Write NIC (Controller IC on the Winchester drive) control signal, and Write Data interface directly to the Disc Controller chip through buffers. Read Data from the flexible disc drive is first received by a Schmitt Trigger Inverter. The Schmitt Trigger helps clean up the data line before it is interpreted by the PLL. The digital PLL recovers the Read Clock from the flexible disc drive Read Data line.

The Winchester disc data is also cleaned up by a Schmitt Trigger before being passed on to an Analog PLL. The PLL separates the clock and data from the Raw Read Data. The Disc Controller controls when the PLL should provide data by using the Read Gate signal, while the PLL indicates to the Disc Controller when it is synchronized with the disc data using the In-Sync line.



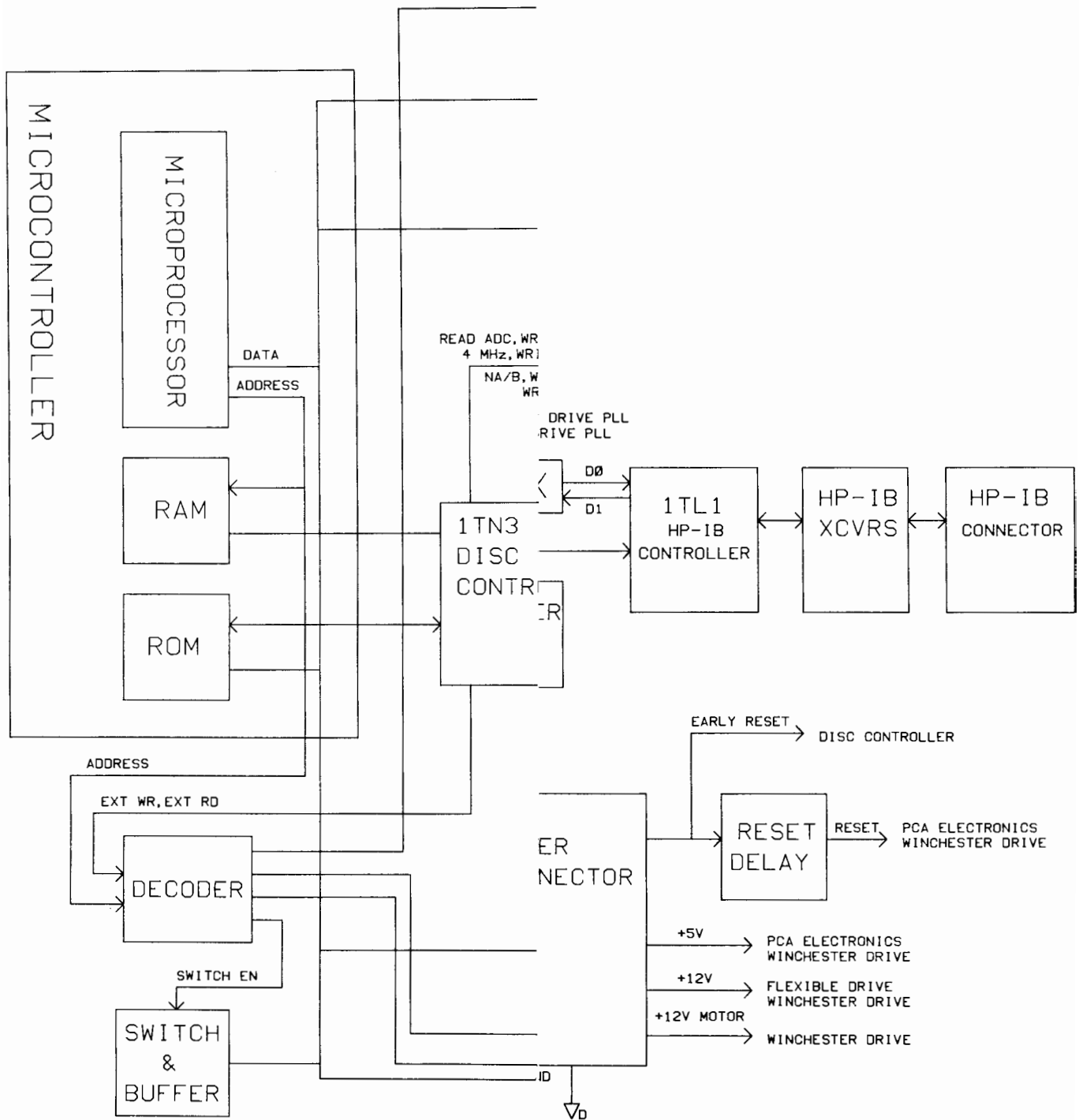

Figure 5-4.
HP 9153/54B Block diagram.

REMOVAL AND REPLACEMENT

CHAPTER

6

This chapter provides information for disassembly of the HP 9153B and HP 9154B disc drives. An exploded view of the HP 9153B, Figure 9-1 in Chapter 9, may be used for reference. This figure serves to show parts in both the HP 9153B and the HP 9154B.

Single products and groups of products that use the 3 1/2-inch Winchester drive are found by referring to the tab on the right side of the page in this chapter.

[1] INTRODUCTION

The following tools are required for disassembly and reassembly of the HP 9153B/HP 9154B.

- #1 Pozidrive screwdriver (HP part number 8710-0899)
- #2 Pozidrive screwdriver (HP part number 8710-0900)
- Needlenose pliers



9153B
9154B

Use Figure 9-1 in Chapter 9 for assembly location. Use Figure 6-1 and 6-2 for cable connector location.

[2] TOP COVER REMOVAL

WARNING

Always disconnect the the disc drive from any AC line voltage before servicing.

To access the internal assemblies, remove the top cover:

1. Remove the two screws located at the rear of the unit.
2. Remove the three screws located on the bottom of the front panel.
3. Slide the top cover forward for removal.
4. To assemble, reverse the above process.

[3] CONTROLLER PCA REMOVAL

To remove the Printed Circuit Assembly (PCA), complete the following steps:

1. Disconnect the DC power, and the drive controller connectors from the controller PCA.
2. Remove the two Pozidrive screws that secure the HP-IB plate, and controller PCA, to the chassis.
3. Slide the controller PCA out the rear of the unit.
4. To assemble, complete the following steps:
 - a. If the original controller is being reinstalled, reverse the above disassembly instructions.
 - b. If a new controller PCA is being installed, perform the following steps:
 - 1) Loosen the HP-IB hex nuts holding the HP-IB plate to the controller PCA
 - 2) Slide the assembly (HP-IB plate and controller PCA) into the chassis
 - 3) Install the two Pozidrive screws securing the HP-IB plate to the chassis
 - 4) Tighten the HP-IB hex nuts using the 7mm hex nut driver.
 - 5) Reinstall all cables to PCA.

[4] POWER SUPPLY REMOVAL

1. Remove the DC power cable and fan cable located at the front of the supply. Remove the cables from the clamp on the shield.
2. Remove the snap-on plastic power supply shield as follows:
 - a. Insert a flatblade screwdriver in the slot located in the top of the plastic shield and apply pressure (with the tip of the blade) towards the side of the chassis (THE SLOT IS USED AS A PRY POINT). This will release the single tab located on this side
 - b. To release the remaining two tabs, pull outward on the side of the shield (closest to the drive) and lift upward. Remove the shield by sliding it out towards the front of the chassis.
3. Remove the three screws that mount the supply to the unit.
4. Lift power supply out of the unit.
5. Remove the two wires on terminals N and L located at the rear of supply.
6. To assemble, reverse the above process except for 2a and 2b. To re-install the shield, do the following:

Align the shields three tabs over the appropriate notches in the power supply

Push shield onto the the power supply.

[5] DRIVE REMOVAL

Refer to Figure 6-3 for the jumper configuration of the drives.

1. Removal of the 3 1/2-inch flexible disc drive from drive mounting assembly
 - a. Remove the screw located at the rear of the drive which secures the drive mounting plate to the drive mounting assembly.
 - b. Grasp the drive mounting plate near the screw hole which secures it to the drive mounting assembly, and lift the drive mounting plate up and away from the slot in drive mounting assembly.
 - c. Remove the three screws that secure the drive to the drive mounting plate.
 - d. To assemble, reverse the above process.

2. Removal of the 3 1/2-inch Winchester disc drive from the drive mounting assembly

- a. Remove the screw located at the rear of the drive which secures the drive mounting plate to the drive mounting assembly.
- b. Slide the drive mounting plate and drive towards the back of the drive mounting assembly and lift upwards removing the assembly.
- c. Remove the three screws that secure the drive to the drive mounting plate.
- d. To assemble, reverse the above process.

9153B
9154B

NOTE

Care should be taken to ensure proper fit of the flexible disc drive front bezel into the front panel opening (9153B only).

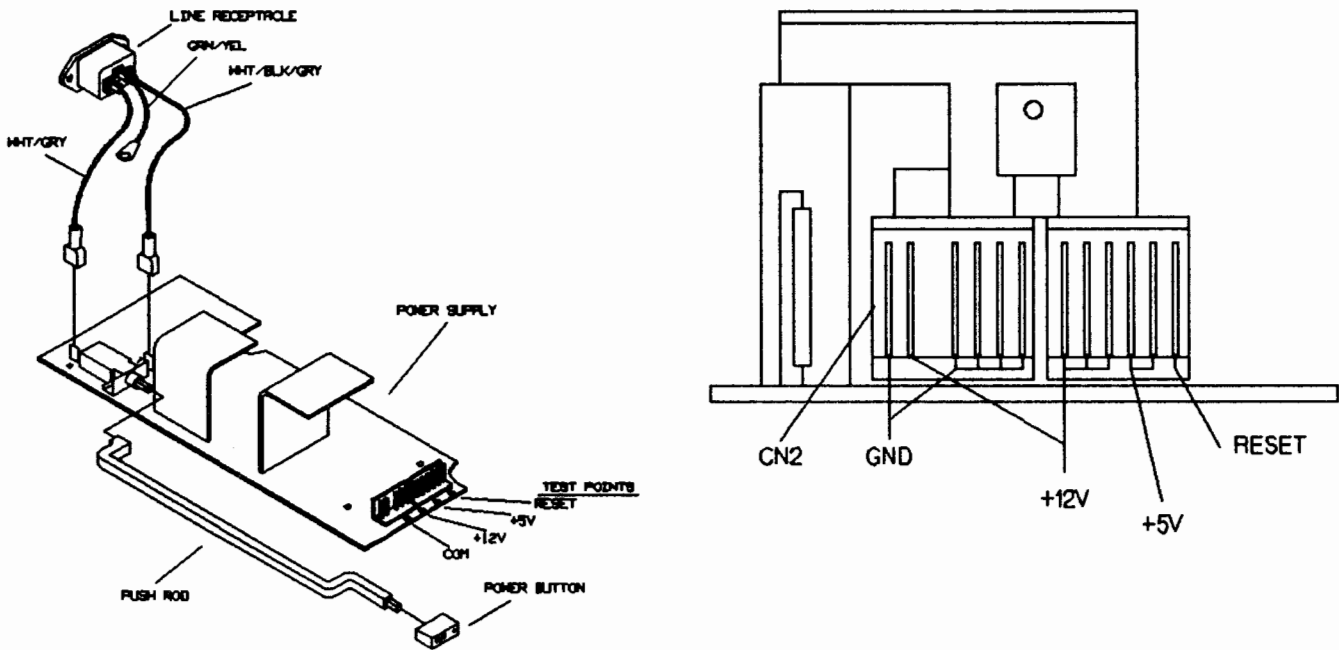

Figure 6-1. HP 9153B/HP 9153B power supply.

9153B
9154B

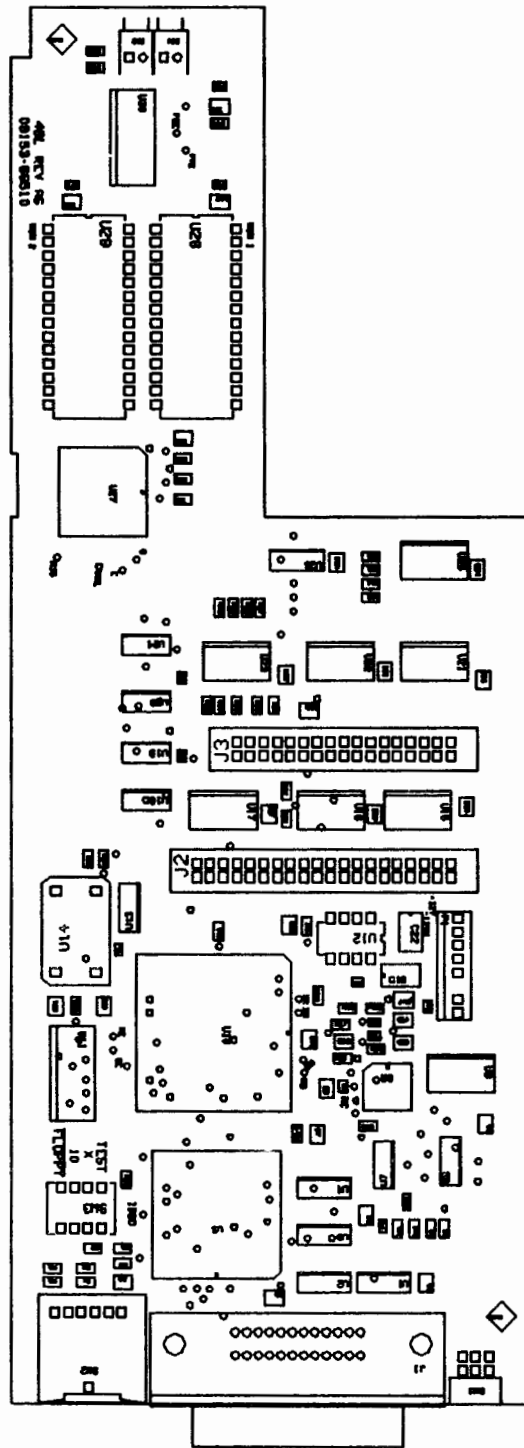

Figure 6-2. Controller PCA.

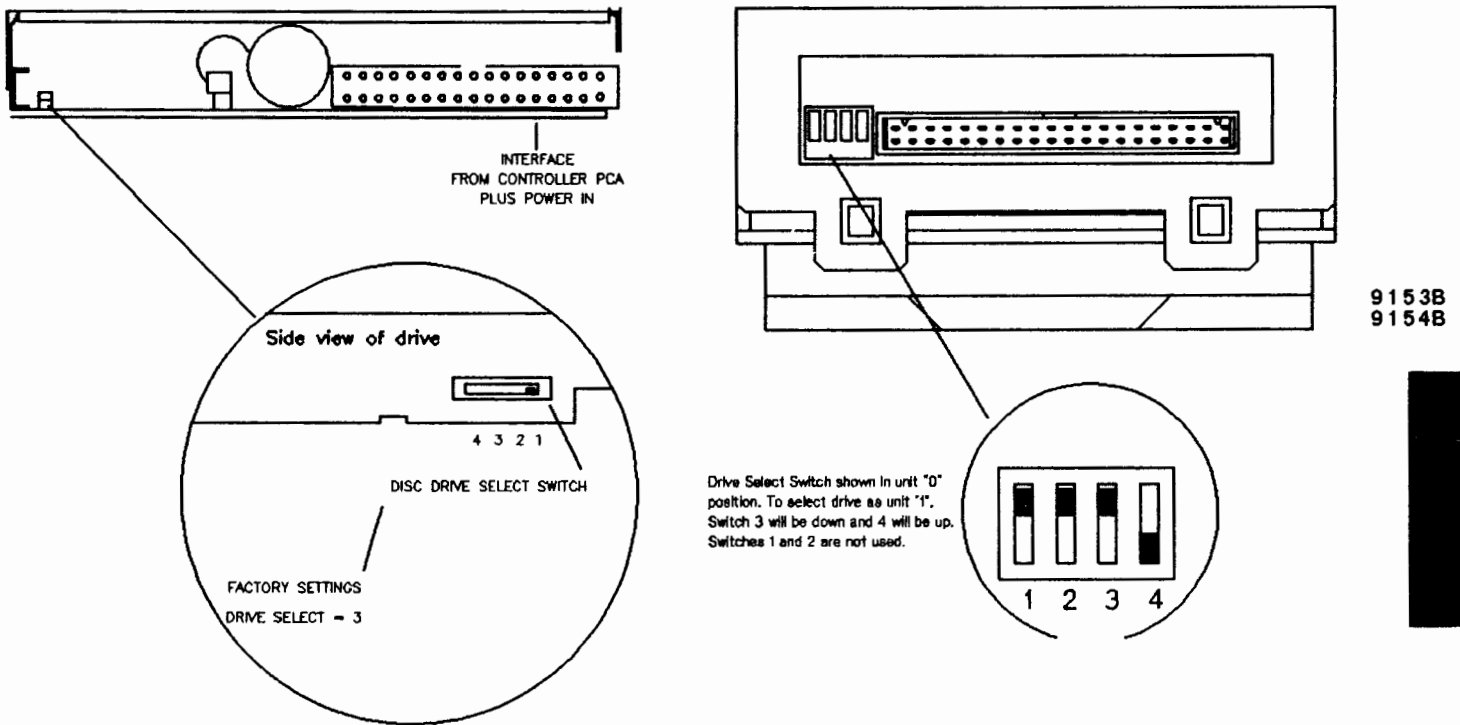

Figure 6-3. HP 9153B/HP 9154B drive configurations.

ADJUSTMENTS

CHAPTER

7

There are no adjustments for the HP 9153B/HP 9154B disc drives.

Single products and groups of products that use the 3 1/2-inch Winchester drive are found by referring to the tab on the right side of the page in this chapter.

TROUBLESHOOTING AND DIAGNOSTICS

CHAPTER

8

This chapter defines the available selftest capabilities of the products, the results of running the individual Service Selftest, and the order in which Service Selftest should be run.

Single products and groups of products that use the 3 1/2-inch Winchester drive are found by referring to the tab on the right side of the page in this chapter.

[1] REPAIR PHILOSOPHY

The HP 9153/54B are serviced by replacing major assemblies. Repair at a lower level than major assemblies is not supported.

The part numbers for the major replaceable assemblies are as follows:

3 1/2-inch Flexible Disc Drive	-- 09123-69101
Controller PCA	-- 09153-69510
3 1/2-inch Winchester	-- 45816-69111
Fan	-- 09144-68501
Power Supply	-- 09153-67110
AC Line Filter	-- 09153-68802



9153B
9154B

Defective assemblies are identified by observing a system in operation, using the power-on selftest and service tests in the firmware, and by use of the SS/80 Exerciser.

[2] PREPARATION FOR TROUBLESHOOTING

Remove the top cover as described in Chapter 6, Section 2, to provide access to the switches used in troubleshooting.

[3] POWER SUPPLY ASSEMBLY

Power supply voltages should be checked before any troubleshooting procedures are started. The following figure shows the location of power supply voltage test points. This will aid you in isolating the failure to a replaceable assembly. The power supply is not an exchange assembly.

TROUBLESHOOTING AND DIAGNOSTICS

9153B
9154B

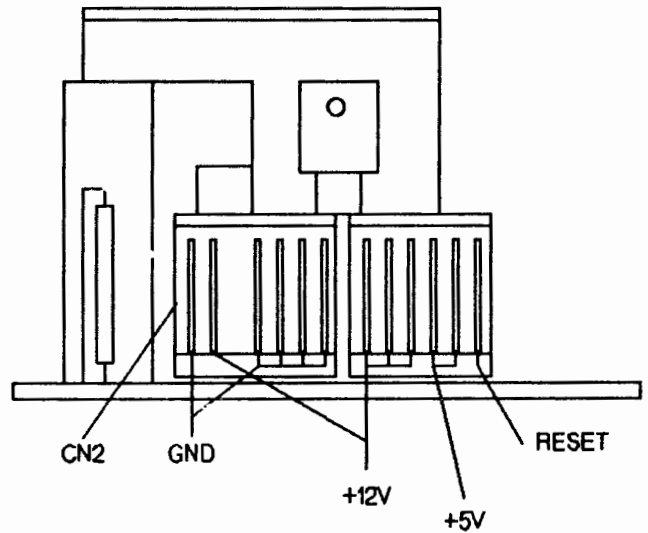
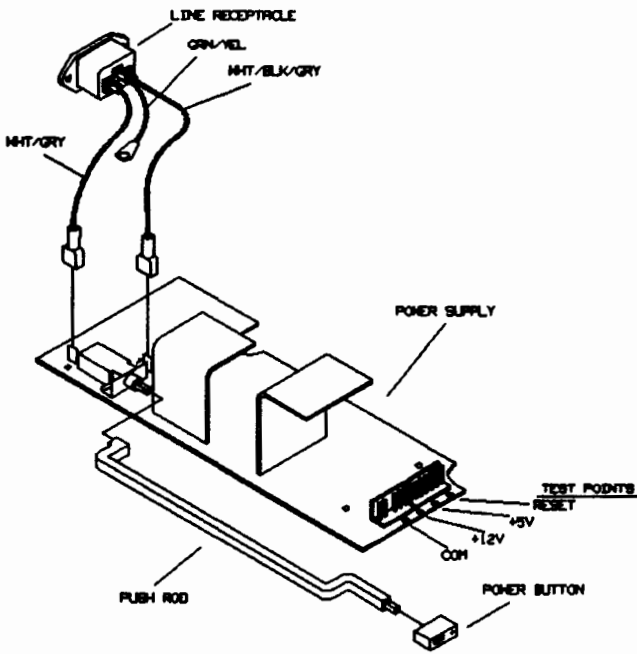

POWER SUPPLY SPECIFICATIONS

+5 Vdc	4.75 - 5.25 Vdc
+12 Vdc	11.4 - 12.6 Vdc

Figure 8-1. Power Supply PCA.

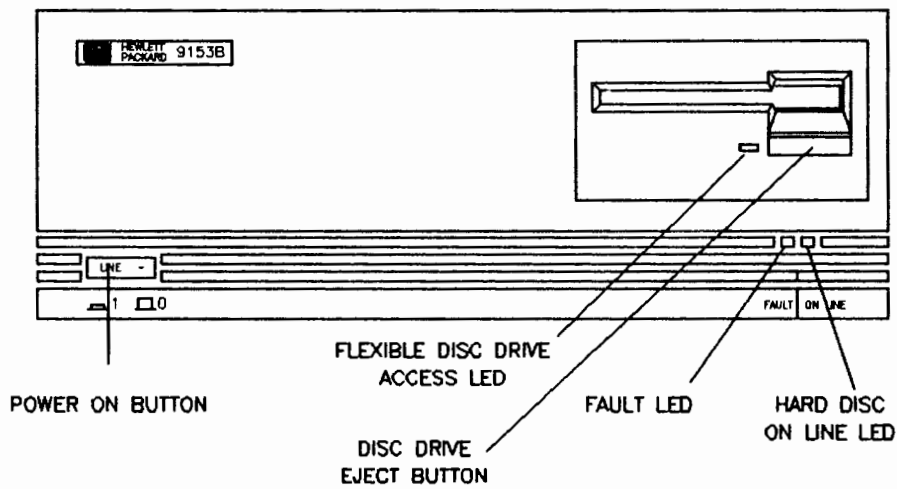

Figure 8-2. Front panel Control Indicators.

[4] SELFTESTS

Refer to Figure 8-2 for location of LEDs mentioned in the following text.

Selftest routines can be initiated in 3 different ways:

1. At power-on, a selftest of the Processor, ROM, HP-IB chip, RAM, Buffer RAM and both drives are performed. The Winchester disc drive test includes reading and writing sectors, checking the spindle speed, and checking that the error correction circuitry functions correctly by introducing errors and correcting them. The FAULT LED stays on if the power on selftest fails.
2. An "Initiate Diagnostic" may be given from the host computer. Tests normally run at power-on are done. (This is currently available only with the HP85 Service System.)
3. If the HP85 Service System is not available, setting the "TEST" switch of SW3 on the controller PCA to the TEST position, will put the unit into the Service Selftest mode. The results of a successful test are displayed by the FAULT LED blinking five times (once per second) followed by a complete power-on sequence. A failure causes the FAULT LED to stay on.

9153B
9154B

The following discussion will cover items 1 and 3 above.

TEST PERFORMED DURING POWER-ON

At power-on, a sequence of tests checks the Processor, ROM, HP-IB chip, Processor RAM, Buffer RAM, and the drive(s). The Winchester disc drive test reads and writes sectors, checks the spindle speed, and checks that the error correction circuitry is functioning.

When the HP 9153B or HP 9154B is first powered on, the ONLINE LED and the FAULT LED come on. The FAULT LED will come on as each of the tests in the power-on sequence is executed and remain on until each test is finished. In the case of a 9153B, the ONLINE LED goes off and the flexible disc drive ACCESS LED comes on when the flexible disc part of the testing begins (This assumes that the Winchester is unit "0".)

A failure of a test in the power-on sequence is displayed by the FAULT LED blinking with specific patterns as explained below.

If the FAULT LED remains on continuously after the ONLINE LED and the flexible disc drive ACCESS LED have gone off, something has failed or Winchester disc drive is not initialized.

TROUBLESHOOTING AND DIAGNOSTICS

LED INDICATIONS DURING POWER-ON

The FAULT LED will give an indication of what has failed during the power-up test as follows:

1. Both LEDs (FAULT LED and ONLINE LED) stay off. The microprocessor has failed.
2. Both LEDs stay on. The microprocessor failed power-on test or the main CPU RAM failed.
3. FAULT LED on 6 seconds, blinks off 1 time, repeats. Rom checksum is wrong.
4. FAULT LED on 6 seconds, blinks off 2 times, repeats. Processor RAM is bad.
5. FAULT LED on 6 seconds, blinks off 3 times, repeats. The buffer RAM is bad.
6. FAULT LED on 6 seconds, blinks off 4 times, repeats. The configuration switches are set to an illegal configuration.
7. FAULT LED on 6 seconds, blinks off 5 times, repeats. The HP-IB chip is bad.
8. FAULT LED on 6 seconds, blinks off 6 times, repeats microprocessor has failed.
9. FAULT LED on 7 seconds, blinks off 7 times, repeats. The Disc Controller chip is bad.
10. The drives are then tested in unit number order. Testing continues even if a failure occurs.

Following is a list of the items checked on each drive:

Winchester Disc Drive

- Check whether drive is connected.
- Initialize the seek table.
- Recal to 0.
- If the drive is initialized then
 - build the seek table
 - perform a write/read compare test on the system (no user data affected)
 - perform an ECC test.

Flexible disc drive

- A seek test is done.
- If media is in the drive, then the index period is checked.
- If the disc in the drive is single sided format, then testing is complete.
- On double sided discs, if the disc is write protected, only a Read test is performed. If the disc is not write protected, a write, read, and compare test is performed (all writing is done in non-data areas, no customer data is at risk).

If all the tests pass, the FAULT LED goes out and the HP 9153/54B is ready for use.



EXECUTION OF SERVICE SELFTESTS

There are eight selectable service selftests available. The list of tests follows this explanation of procedure and the example of running the RAM test.

The Service Selftests are enabled as follows:

1. Remove power from the unit to be tested.
2. Select the test to be executed with the HP-IB address switch. (See P.8-8 for a description of the test.)
3. Set the "TEST" section of SW3 to ON (See Figure 8-6, P.8-18)
4. Apply power to the unit.
5. The following sequence of events should occur:
 - a. The unit will go through a complete power up sequence. The ONLINE and flexible disc drive ACCESS LED will be off at the conclusion of the power-on sequence.
 - b. The FAULT LED remains on for approximately 4 seconds, blinks off, then comes on again as execution of the selected test begins.
 - c. If the selected test is successful, the FAULT LED will blink off five times, remain on for approximately four seconds, then repeat the test. Additional tests may be selected by moving the HP-IB switch to the desired test if the current test is not the RAM test (Test 0). See procedure for RAM test below.
 - d. If the test fails, the FAULT LED remains on at the completion of the test, no further testing occurs, and no other Service Selftest can be selected without power cycling the unit.

9153B
9154B

NOTE

Because the RAM test clears all parameters, some of which are needed for other tests, do not switch arbitrarily from test to test. The RAM test should be performed first or be the last test which is run. After each RAM test the unit must go through its power-on sequence.

The following is an example of running the RAM test as the first test performed.

1. Turn off the power to the unit.
2. Select the RAM test (0 on the HP-IB address switch) and set the "TEST" switch of SW3 to the TEST position.
3. Turn on power. The unit will go through a complete power-on sequence, then begins executing the RAM test. The FAULT LED remains on during the test. When the test is completed, the FAULT LED should blink 5 times. If the FAULT LED remains on continuously, the test failed.
4. Turn power off. Select the next test using the HP-IB address switch. Do NOT select the RAM test.

More tests may be selected as needed (except the RAM test) without turning the power off. There is a delay after the selection of a test until execution of the test is begun.

TROUBLESHOOTING AND DIAGNOSTICS

FAULT LED INDICATIONS DURING EXECUTION OF SERVICE SELFTESTS

The FAULT LED will go on for one second (To show that it works) at the beginning of each test. The LED will then go on, and stay on, during the length of the test. A pass indication is displayed by the FAULT LED blinking 5 times. A failure is displayed by the FAULT LED remaining on.

SERVICE SELFTESTS AVAILABLE

9153B
9154B

TEST #		TEST TIME		TEST DESCRIPTION
		Min	Sec	
0	RAM		: 2	All possible patterns are written in all locations of the microprocessor RAM
1	ROM		: 3	A checksum calculation is performed.
2	CONTROLLER		: 1	The HP-IB chip, Disc Controller chip, and buffer RAM are tested.
3	FLEXIBLE		: 3	A seek test, index period test, and a Write/Read compare on the system cylinder are performed on the flexible disc drive.
4	FLEXIBLE DISC DRIVE VERIFY		:40	All sectors in the data area of the disc are checked for CRC errors. No user data is affected.
5	FLEXIBLE DISC DRIVE FORMAT	1	:40	Formats disc.
6	WINCHESTER	7	:30	A thorough seek test, a W/R/compare on the system cylinder, and a recalibration is performed on the Winchester disc drive.
7	WINCHESTER VERIFY	2	:30	All sectors in the data area of the disc are checked for CRC errors. No user data is changed.
8	WINCHESTER CONNECTED		: 1	Checks to see if the Winchester is connected.
9	ECC			Checks the error correction portion of the Disc Controller chip.

If a Flexible disc drive test is selected on the HP 9154B, the test will fail.

[5] TROUBLESHOOTING PROCEDURES

This section is divided into General information, a troubleshooting flowchart, procedures called out in the flowchart, repair verification, and use of the SS/80 Exerciser.

GENERAL INFORMATION

9153B
9154B

- If a flexible disc is damaged by the flexible disc drive (9153B), replace the drive mechanism.
- If the fan is not operating, check that the HP 9153/54B is receiving primary power; that the voltage select switch is set correctly, and that the primary fuse is good. Also check the power supply voltages. Use Figure 8-1 for location of voltage test points.
- If possible, determine whether the customer has been using HP double-sided media. If the customer is using media from other sources, or HP single-sided media in double-sided mode, it is possible that media could be the cause of the problem.

Some media related problems that have occurred are visible wear of the disc and a high pitched sound from the drive while the disc is being accessed. These problems have occurred when single-sided HP media is being used heavily in a double-sided drive (instead of its intended use to exchange data with single sided disc drives) and with media from other vendors. Note that the head resonance problem may be found occasionally as an independent failure mode.

Additional media related problems (HP 9153B) may occur such as failure to initialize media, and intermittent failures. In some cases, media may cause an accumulation of residue on the read/write head of the disc drive. It must be removed, if possible, before the drive will work properly with HP media. Heads may be cleaned using the 09122-89415 cleaning disc and the HD_CLN routine in the SS/80 Exerciser SERVC module to exercise the disc drive during the cleaning.

CAUTION

A precaution to be taken in troubleshooting the HP 9153/54B is that the drive mechanism, 45816-69111, is also a common part used to repair the 45816A (internal 20M byte drive in Vectra PC) with serial number prefix 2552A or higher. As the drive comes into the service pipeline, it can be used to service either the 45816A (Vectra) or the 9153/54B. However, if the drive is ever formatted in the HP 9153/54B, it cannot then be used in a 45816A. In cases where there is a question whether the controller or the Winchester drive is defective, the controller should be substituted first, and then replaced with the original controller if it is not defective before replacing the Winchester disc drive.

NOTE

If a replacement Winchester is installed in the HP9153B or HP 9154B, the power-on selftests will fail when the unit is powered up. The drive must be initialized (or formatted), and the unit power cycled before the FAULT LED will go off.

TROUBLESHOOTING FLOWCHART

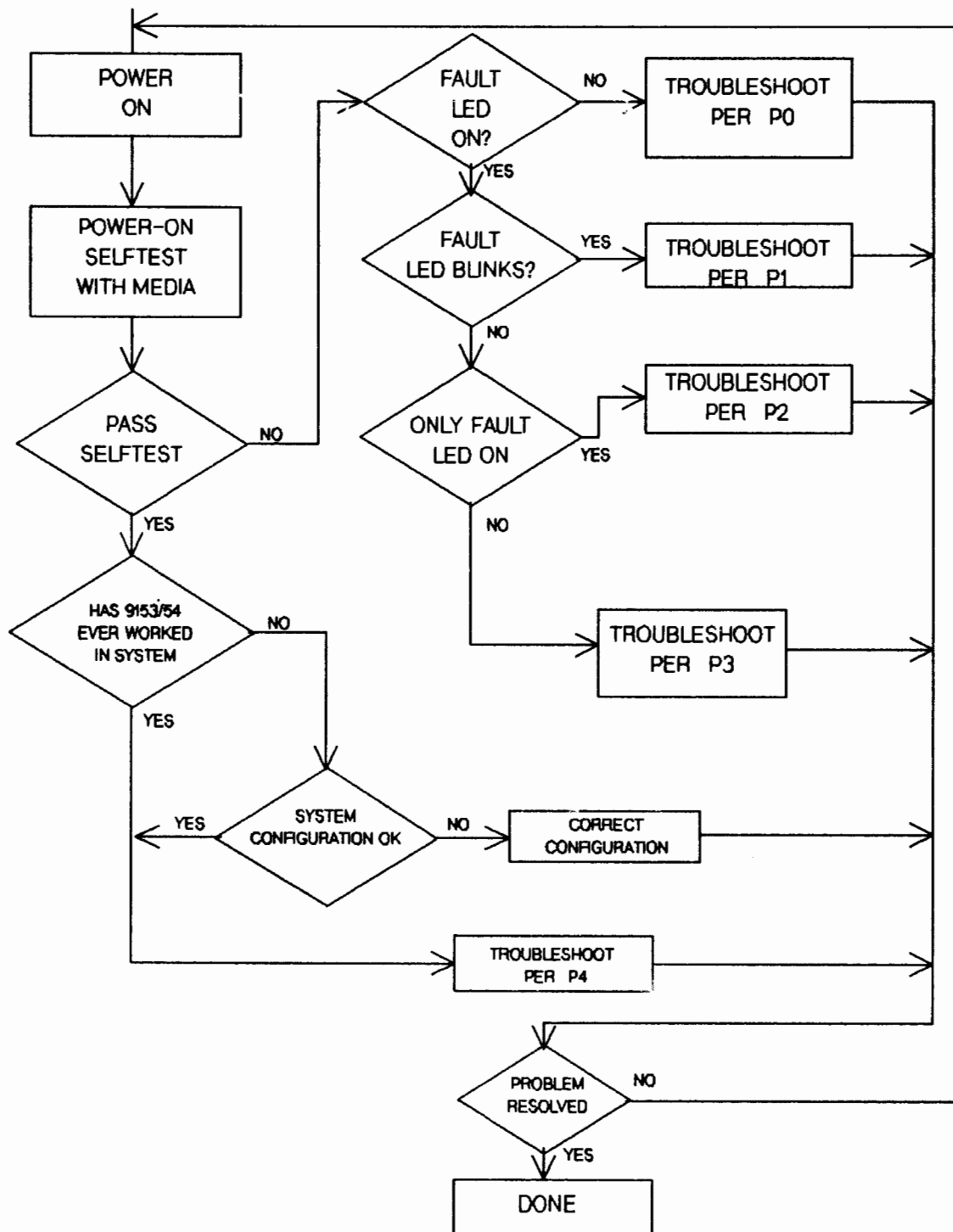

Figure 8-3. Troubleshooting Flowchart.

9153B
9154B

PROCEDURES P0 THROUGH P4**PROCEDURE P0** (LED's not on at power on)

1. Check primary fuse
2. Check setting of the primary voltage select switch (See Figure 8-7).
3. Check power supply voltages on the power supply PCA. (See Figure 8-1)
4. Check cables to power supply and drives.
5. Replace controller assembly if preceding steps do not correct problem.

9153B
9154B**PROCEDURE P1** (FAULT LED blinks)

The complete description of the power-on selftest indications is provided on page 8-6. The following information indicates the probable repairs if the FAULT LED is blinking at power on:

INDICATION	PROBLEM
FAULT LED on 6 seconds, blinks off 1 time, repeats	ROM checksum wrong. Replace ROM's or controller board
FAULT LED on 6 seconds, blinks off 4 times, repeats	Controller configuration switches set to an illegal configuration. Set switches for correct configuration for product. (See Figure 8-6, page 8-18)
All other FAULT LED blink indications	Controller fault. Replace the controller.

PROCEDURE P2 (FAULT LED on)

Drive access is indicated by the ONLINE indicator for the Winchester disc and by the ACCESS LED on the flexible disc drive front panel for the flexible disc drive. The ONLINE indicator will normally light momentarily at the time power is applied, then come on again at the time the drive begins spinning up and remain on for approximately 25 seconds during the power-on selftest. The ACCESS LED on the flexible disc drive will come on only if media is inserted in the drive, and will remain on for approximately 4 seconds.

NOTE

If the Winchester disc has just been replaced, it is necessary to format the drive and then cycle power before the product will pass the power-on selftest.

Neither drive accessed during selftest (9153B only)

1. Check power supply voltages (Figure 8-1)
2. Ensure that all cables are connected properly.
3. Ensure that configuration switch on the controller board is set correctly. (Figure 8-6)
4. Replace controller if none of the above correct the problem.

TROUBLESHOOTING AND DIAGNOSTICS

Winchester not accessed during selftest

Assure that the Winchester disc is spinning up. A very distinct audible indication occurs within the first 10 seconds after power is applied if the disc is spinning up.

1. Check power supply voltages (Figure 8-1)
2. Ensure that all cables are connected properly.
3. Ensure that configuration switch on the controller board is set correctly. (Figure 8-6)
4. Ensure that configuration switch on drive (See Figure 8-4) is set correctly.
5. Replace controller if none of the above correct the problem.
6. Replace the original controller in the product and replace drive if controller replacement does not correct problem.

9153B
9154B

Flexible disc not accessed during selftest (9153B only)

1. Ensure that a disc is installed into the flexible disc drive.
2. Check power supply voltages (Figure 8-1)
3. Ensure that all cables are connected properly.
4. Ensure that configuration switch on the controller board is set correctly. (Figure 8-6)
5. Ensure that configuration switch on drive (See Figure 8-4) is set correctly.
6. Replace controller if none of the above correct the problem.
7. Replace the original controller in the product and replace drive if controller replacement does not correct problem.

Both drives accessed during selftests (HP 9153B only)

It is possible that either a controller or drive can cause this fault. The two types of drives use some different circuits on the controller, and it is not always clear whether the controller or the drive is causing a problem related to apparent failure of a drive.

1. Place the FLOPPY section of SW3 to the ON position and repeat the power-on selftest. If the power-on selftest passes, replace the flexible disc drive. (Make sure the FLOPPY section of SW3 is returned to the proper position for the HP 9153B.)
2. If failure persists, return SW3 to the correct position and replace the controller PCA.
3. If the failure persists, replace the original controller in the HP 9153B and replace the Winchester disc drive.

PROCEDURE P3 (FAULT and ONLINE or FAULT and flex ACCESS LED's on)

Controller is the most probable defective assembly. Replace controller and re-test. If failure persists, replace the Winchester disc drive if the ONLINE LED is on, or replace the flexible disc drive if the flexible disc access light is on.

PROCEDURE P4 (Failure in system but passes power-on selftest)

Flexible disc failing

1. Determine whether HP double-sided media is being used in the system. Some media, including HP single-sided media, will not perform properly in the HP 9153B when the

flexible disc drive is used heavily. (If the disc has been used heavily with some types of media it is possible that the head may require cleaning before HP double-sided media will perform properly. The only means to do this is to use the SS/80 Exerciser on the HP 85.

2. Verify failure by using Test #4 (see page 8-8) on a customer data disc (verifies but does not change data) if read problems are occurring.
3. Check read/write performance using Test #5 on a scratch disc. (Formats the disc)

NOTE

Tests #4 and #5 will continue to loop until an error is detected, at which point the test will terminate and the FAULT LED will remain on continuously.

9153B
9154B

4. Replace drive if failure is indicated.
5. If failure persists, replace the original drive in the product and replace the controller board.

Winchester disc failing

1. Attempt to verify that failure is the Winchester disc using Test #7.
2. If Test #7 does not indicate a failure, replace the controller.
3. If failure persists, replace the original controller in the product and replace the Winchester disc drive.

Neither drive can be accessed

1. Replace controller board

REPAIR VERIFICATION

After repair of the product, the repair should be verified to ensure that the product is operating properly. If the test is on the flexible disc drive, format a disc using either a host computer which supports the product, the SS/80 Exerciser, or Service Selftest number 5. If the SS/80 Exerciser is available, the R/W_TEST module can be used to loop on a write/read test. Test number 5 formats a flexible disc, and will continue to loop on that test until the test fails, thus providing a means to exercise the product without operator intervention.

If the repair is on the Winchester disc drive and if there is no customer data on the disc, the repair can be verified by formatting the disc. If the disc has been divided into volumes, each volume must be formatted. If the customer's data must be preserved on the disc, the R/W_TEST module in the SS/80 Exerciser provides a read-only test which will not affect customer data. Test number 7 also provides a verify test which will not affect customer data, and allows the test to execute continuously until an error is detected.

If the repair is on the controller, repair can be verified by performing write and read operations on both drives.

THE SS/80 EXERCISER

The SS/80 Exerciser provides some capabilities that are not available otherwise, and also provides more information about the HP 9153/54B than is otherwise available. Specifically, the Exerciser provides the capability to transfer data and commands between a host computer and the peripheral, as well as performing certain tests which cannot be implemented in any other way.

Please refer to the SS/80 Exerciser manual, P/N 5958-4142 for an overview of the capabilities contained in the Exerciser.

9153B
9154B

Some general testing solutions which can be implemented using the Exerciser are as follows:

HP-IB channel test	The LOOPBAK test in the MANUAL module tests the capability to communicate with the product across the HP-IB.
Testing for R/W errors	The R/W_TEST module allows either a Read Only, or a Write then Read test to be performed on a single unit. This test can be set to loop up to 32,000 times and allows extensive testing to identify a problem or verify a repair.
General product evaluation	The R/W_TEST module provides capability to perform general product testing and is recommended for this use.
Flexible disc tests	The SERVC module contains special flexible disc drive tests—motor speed, Track 0, Head cleaning routine, etc.
Complete product evaluation	The OPER program provides the capability to test all units and volumes of a disc drive without manually selecting each one. An OPER program can be defined which will select each unit and volume and then perform a locate and verify, locate and read, locate and write, etc. The program will allow looping to perform extensive testing.

If the drives are removed or replaced, refer to Figure 8-4 for the proper setting of the drive select switch.

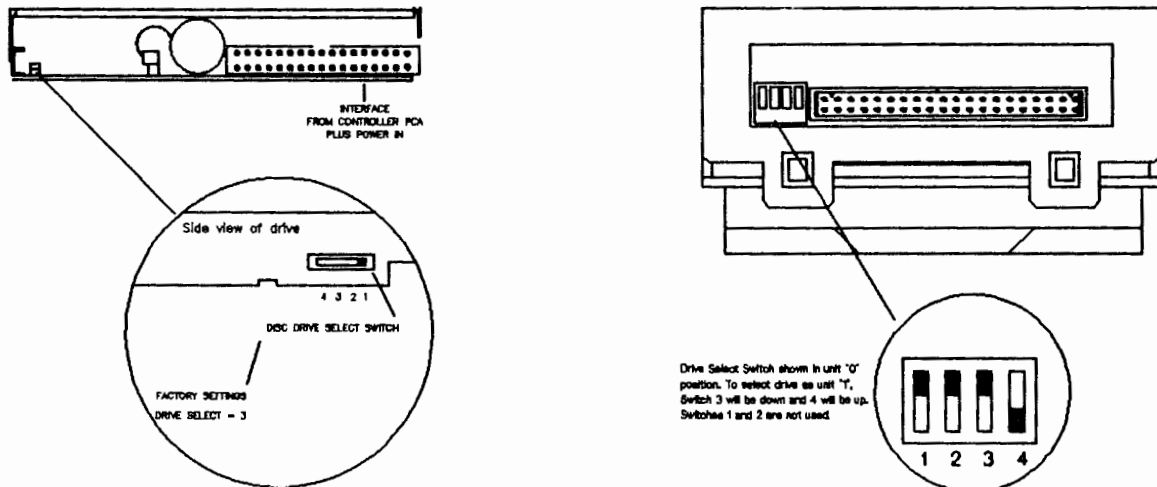

Figure 8-4. HP 9153B/HP 9154B drive configurations.

[6] CONNECTOR PIN DEFINITIONS**3 1/2-inch Winchester Disc Drive**

Pin #	Function
1	Read Data
2	Ground
3	Write Data
4	Ground
5	Write Gate
6	Ground
7	4 MHz Clock
8	Ground
9	Read A/D Converter
10	Ground
11	+5V
12	Ground
13	+5V
14	Ground
15	+12V for Motor
16	Ground for Motor
17	+12V for Motor
18	Ground for Motor
19	Drive Select 0
20	Drive Select 1
21	Drive Select 2
22	Drive Select 3
23	Write D/A Converter
24	NA/B
25	Sector Pulse
26	Index Pulse
27	Write NIC chip
28	Reset
29	+12V for Motor
30	+12V for Motor
31	Fault
32	+12V
33	Data Bus 7
34	Data Bus 0
35	Data Bus 6
36	Data Bus 1
37	Data Bus 5
38	Data Bus 2
39	Data Bus 4
40	Data Bus 3

3 1/2-inch Flexible Disc Drive

Pin #	Function
1	Disk Change Reset
2	Disk Change Indicator
3	+5V
4	In Use
5	+5V
6	Drive Select 3
7	+5V
8	Index Pulse
9	+5V
10	Drive Select 0
11	+5V
12	Drive Select 1
13	Ground
14	Drive Select 2
15	Ground
16	Motor On
17	Ground
18	Direction Select
19	Ground
20	Step
21	Ground
22	Write Data
23	Ground
24	Write Gate
25	Ground
26	Track 0 Indicator
27	Ground
28	Write Protect Indicator
29	+12V
30	Read Data
31	+12V
32	Head Select
33	+12V
34	Ready

9153B
9154B

TROUBLESHOOTING AND DIAGNOSTICS

Power Connector (Controller PCA)

Pin #	Function
1	+12V Misc
2	+12V for Nighthawk Motor
3	Ground for Nighthawk Motor
4	Ground for +12V Misc
5	PVAL signal from Power Supply
6	Mechanical Key
7	Ground for +5V
8	+5V

HP-IB Connector

Pin #	Function
1	Data Bus 1
2	Data Bus 2
3	Data Bus 3
4	Data Bus 4
5	EOI
6	Data Valid
7	Not Ready For Data
8	Not Data Accepted
9	Interface Clear
10	Service Request
11	Attention
12	Chassis Ground
13	Data Bus 5
14	Data Bus 6
15	Data Bus 7
16	Data Bus 8
17	Remote Enable
18	Ground
19	Ground
20	Ground
21	Ground
22	Ground
23	Ground
24	Ground

Figure 8-5 shows the cable interconnect for the HP 9153/54B.

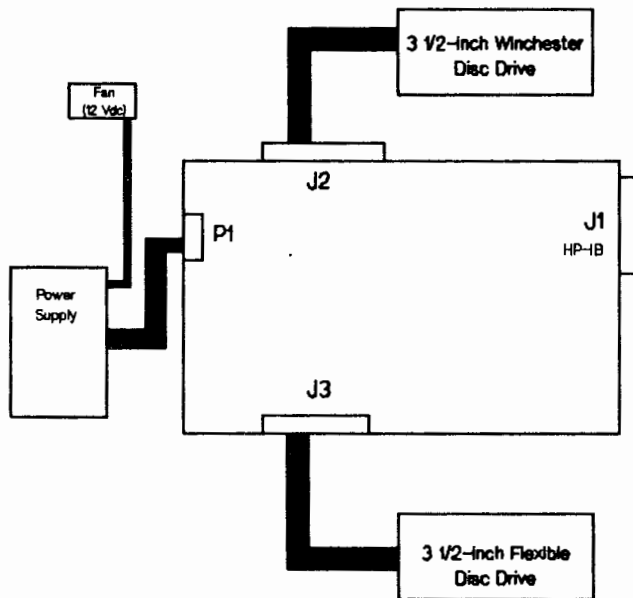
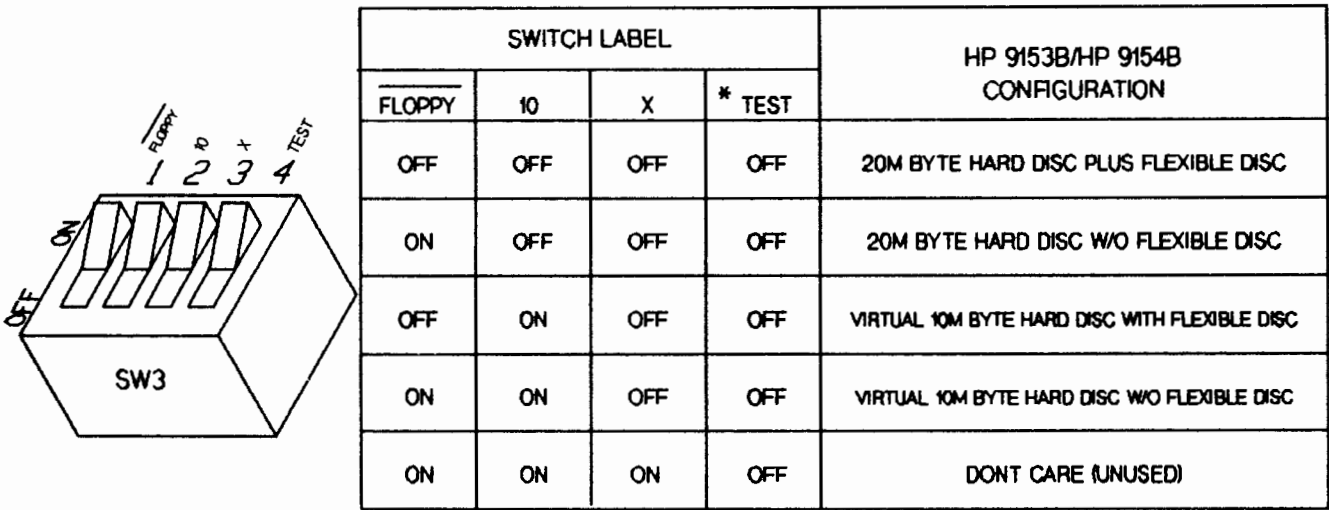

Figure 8-5. Cable Interconnect.



9153B
9154B

* Used to initiate Service Selftest routines.

Figure 8-6. Drive Configuration switch.

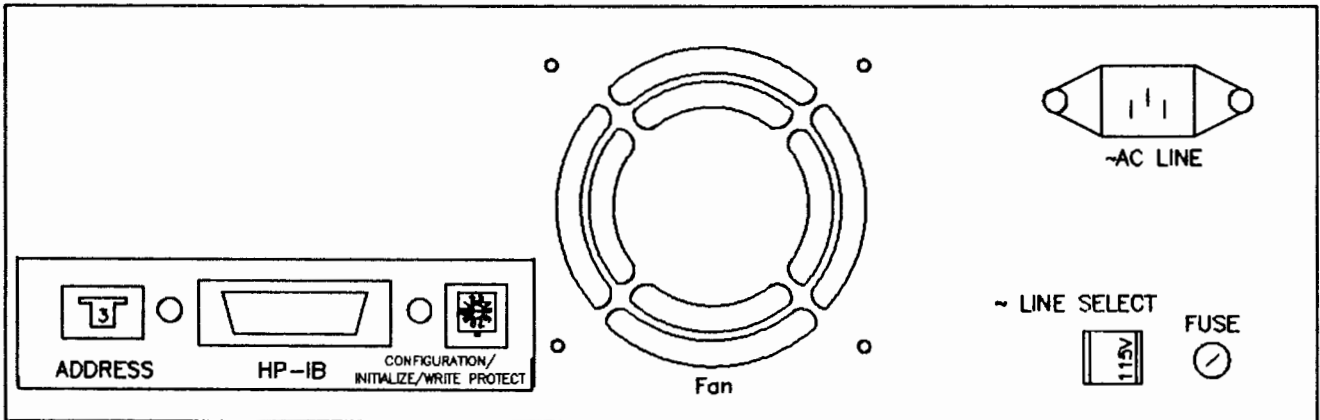

Figure 8-7. Rear View of HP 9153/54B.

REPLACEABLE PARTS

CHAPTER

9



This chapter lists all orderable parts.

Orderable parts, in reference to the products in this chapter, means field-replaceable assemblies. In addition, a listing of component parts of these field-replaceable assemblies is also provided.

Power cords and fuses needed for non-U.S. configurations are listed.

Single products and groups of products that use the 3 1/2-inch Winchester drive are found by referring to the tab on the right side of the page in this chapter.

[1] INTRODUCTION

In the following parts list, the major assemblies are designated by the number "1". All piece parts of that major assembly are designated by a decimal number ".2", and lower level parts by ".3" etc. Use Figure 9-1 for locating the major assemblies.



9153B
9154B



REPLACEABLE PARTS

LEVEL	REFERENCE DESIGNATOR	PART NUMBER	DESCRIPTION
	Use Figure 9-1 for parts location.		EXCHANGE ASSEMBLIES
1	A2	09123-69101	FLEXIBLE DISC DRIVE
9153B 9154B	1	09153-69510	CONTROLLER PCA
1	A1	45816-69111	3 1/2-inch WINCHESTER DISC DRIVE
			NON EXCHANGE ASSEMBLIES
1	A7	09153-67110	POWER SUPPLY
1	A5	09144-68501	FAN
			CASE PARTS
1	A6	09153-04100	TOP COVER
1		09153-40200	FRONT PANEL
1	A8	09153-00101	CHASSIS
1	A4	09153-04702	DRIVE MOUNTING BRACKET
1	A10	09153-40600	POWER SUPPLY SHIELD (TOP)
1	A11	09153-40601	POWER SUPPLY SHIELD (BOTTOM)
1		09153-04104	HP-IB PLATE
1		0403-0427	BUMPER FOOT
1		09121-48303	FOOT-MOLDING
1	A12	09153-04704	DRIVE MOUNTING BRACKET
1	A13	09153-04705	DRIVE MOUNTING BRACKET
			ROMs
1		09153-89101	U28
1		09153-89201	U29

REPLACEABLE PARTS

LEVEL	REFERENCE DESIGNATOR	PART NUMBER	DESCRIPTION
	USE figure 9-1 for parts location		CABLES
	7	09153-61603	FLEXIBLE DISC DRIVE
	6	09153-61604	3 1/2-inch WINCHESTER
			SCREWS
.2	1	0624-0661	
.2	2	0515-1578	
.2	3	0515-1251	
.2	4	0515-1746	
.2	5	0380-1717	
			ELECTRICAL ASSEMBLIES
1	A7	09153-67110	POWER SUPPLY
1	A3	09153-69510	CONTROLLER PCA
1	A9	09153-68802	LINE FILTER
1	A5	09144-68501	FAN

9153B
9154B



POWER CORDS

1	9153A #900	UK power cord
.2	8120-1351	power cable
.2	8120-1378	power cable
1	9153A #901	AUSTRALIAN power cord
.2	2110-0001	1A 250V fuse
.2	2110-0002	2A 250V fuse
.2	8120-1369	power cable
.2	8120-1378	power cable
1	9153A #902	EUROPEAN power cord
.2	2110-0001	1A 250V fuse
.2	2110-0002	2A 250V fuse
.2	8120-1378	power cable
.2	8120-1689	power cable
1	9153A #904	US 240V cord
.2	2110-0001	1A 250V fuse
.2	2110-0002	2A 250V fuse
.2	8120-0698	NEMA 6-15 cord
.2	8120-1378	power cable
1	9153A #905	CEE 22 power cord
.2	8120-1378	power cable
.2	8120-1575	power cable
1	9153A #906	SWISS power cord
.2	2110-0001	1A 250V fuse
.2	2110-0002	2A 250V fuse
.2	8120-1378	power cable
.2	8120-2104	power cable
1	9153A #912	DENMARK power cord
.2	2110-0001	1A 250V fuse
.2	2110-0002	2A 250V fuse
.2	5180-0001	UL label
.2	8120-1378	power cable
.2	8120-2956	cable assembly
1	9153A #917	SOUTH AFRICA power cord
.2	2110-0001	1A 250V fuse
.2	2110-0002	2A 250V fuse
.2	8120-1378	power cable
.2	8120-4211	cord set



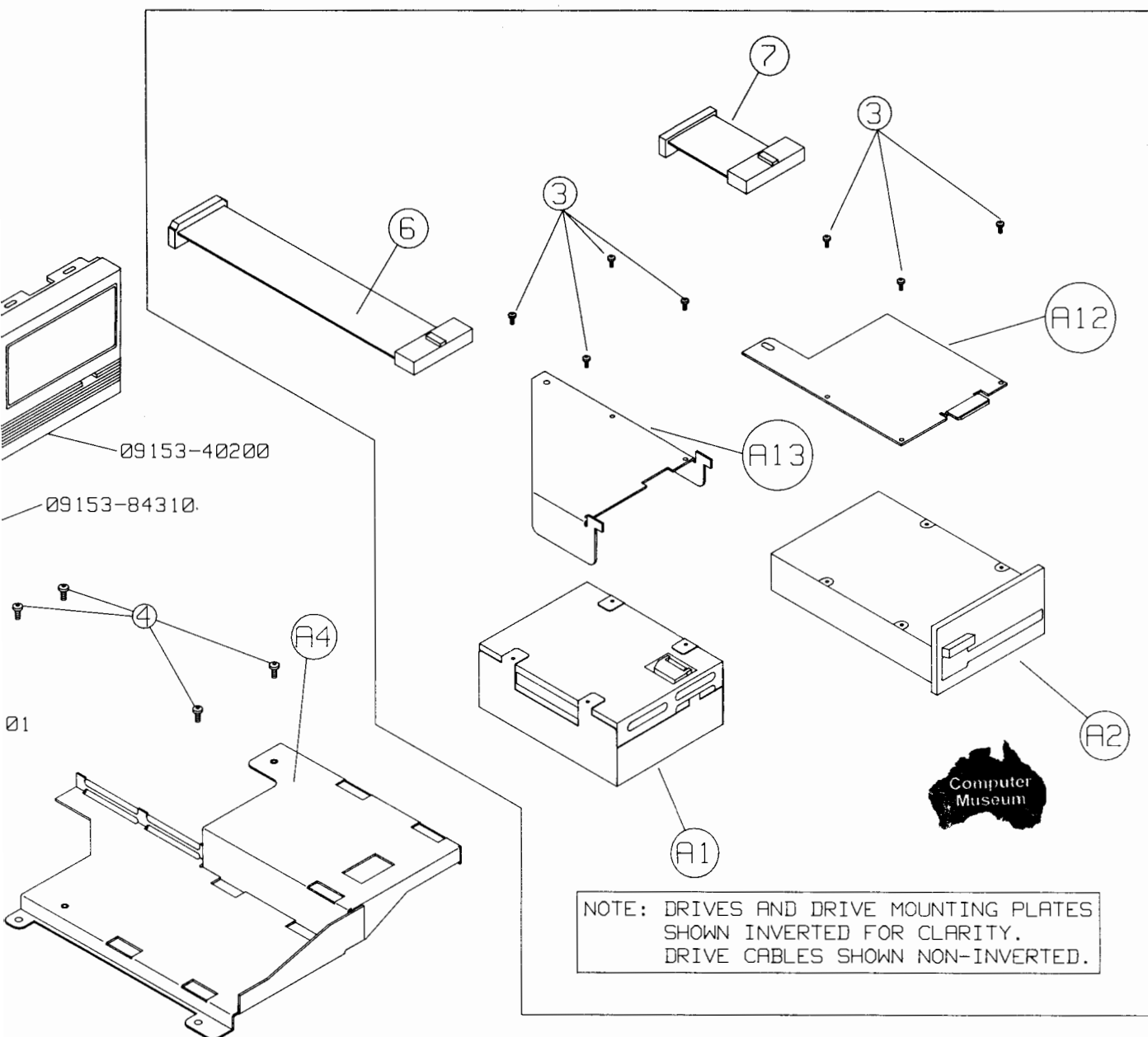

ASSEMBLIES	SCREWS	CABLES
A1 = 45816-69111	1 = 0624-0661	6 = 09153-61604
A2 = 09123-69101	2 = 0515-1578	7 = 09153-61603
A3 = 09153-69510	3 = 0515-1251	8 = 09153-61605
A4 = 09153-04702	4 = 0515-1746	
A5 = 09144-68502	5 = 0380-1717	
A6 = 09153-04100		
A7 = 09153-67110		
A8 = 09153-00101		
A9 = 09153-68802		
A10 = 09153-40600		
A11 = 09153-40601		
A12 = 09153-04704		
A13 = 09153-04705		
A14 = 1400-0650		

Figure 9-1.
HP 9153B exploded view.

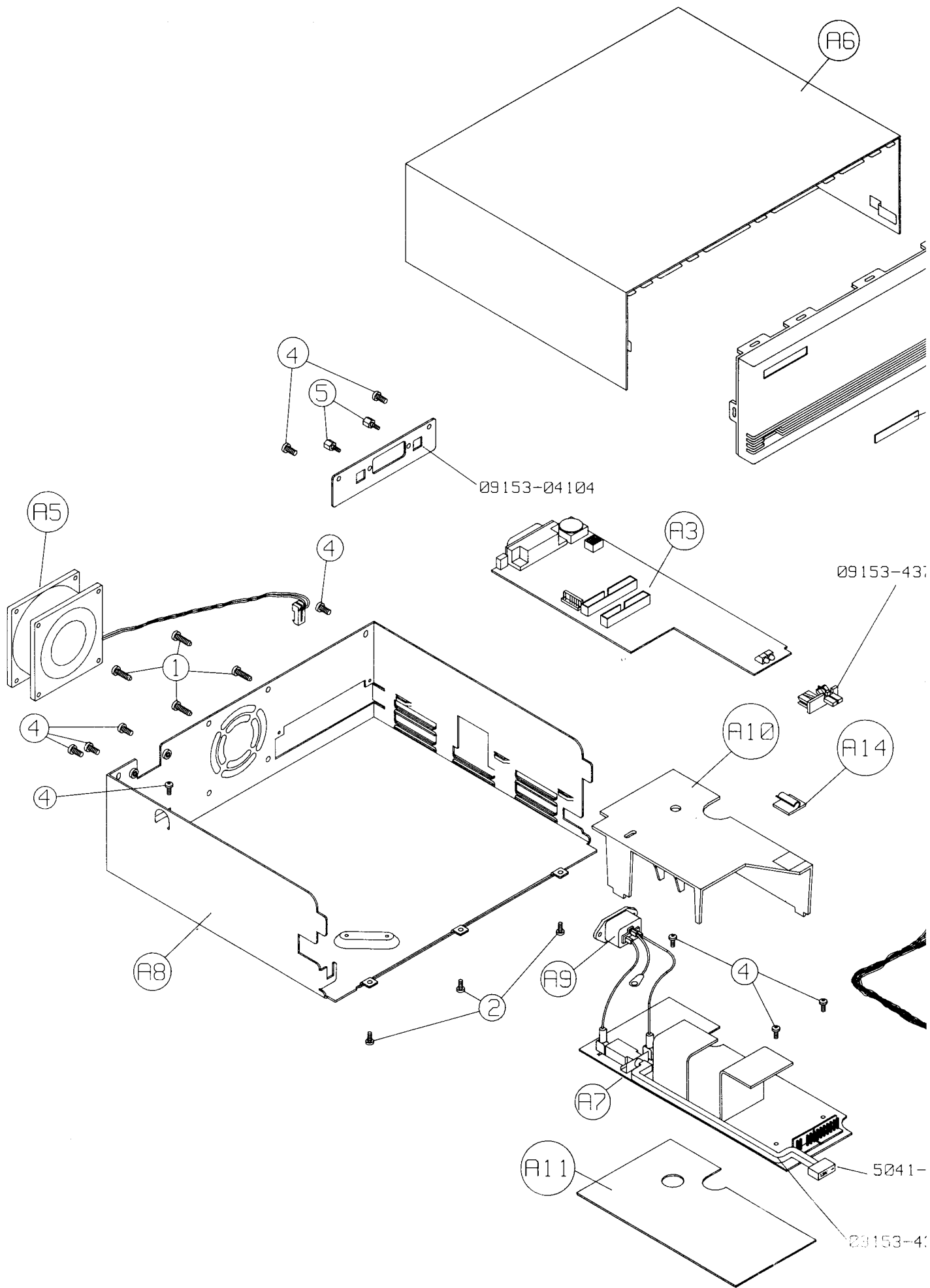

REFERENCE

CHAPTER

10

This chapter lists all material needed to support this manual. This includes non-HP host documentation that is involved in the troubleshooting and configuration of these drives.



Single products and groups of products that use the 3 1/2-inch Winchester drive are found by referring to the tab on the right side of the page in this chapter.

[1] MANUAL REFERENCES

The following documents may be used as reference material:

Subset 80 Reference Manual P/N 5958-4129 - Contains all Subset 80 commands.

SS/80 Exerciser documentation P/N 5958-4142 - Contains information on operation of the SS/80 Exerciser programs.

9153B
9154B



PRODUCT HISTORY

CHAPTER

11

This chapter records changes that are necessary to adapt this manual to an older product.



Single products and groups of products that use the 3 1/2-inch Winchester drive are found by referring to the tab on the right side of the page in this chapter.

[1] HISTORY

This is the original printing of service information for the 3 1/2-inch Winchester Disc Drive as it applies to the HP 9153B and HP 9154B products.

This section of the manual is complete and applies to all HP 9153B/HP 9154B units now in the field. Applicable serial numbers are as follows:

- HP 9153B - serial numbers prefixed by 2633A.
- HP 9153B - serial numbers prefixed by 2634A.

9153B
9154B



DIAGRAMS

CHAPTER

12

No additional diagrams are needed for service.

Single products and groups of products that use the 3 1/2-inch Winchester drive are found by referring to the tab on the right side of the page in this chapter.

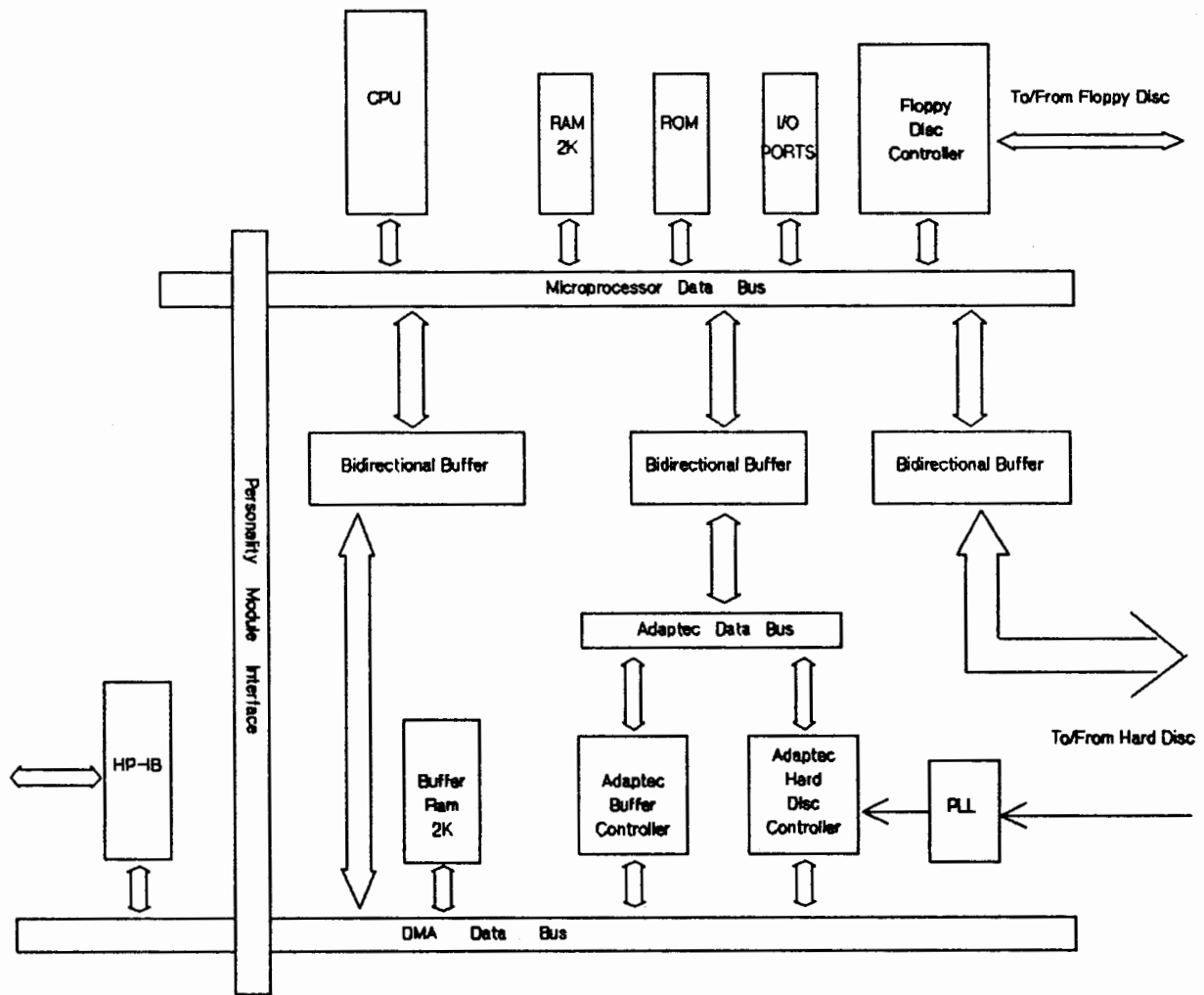
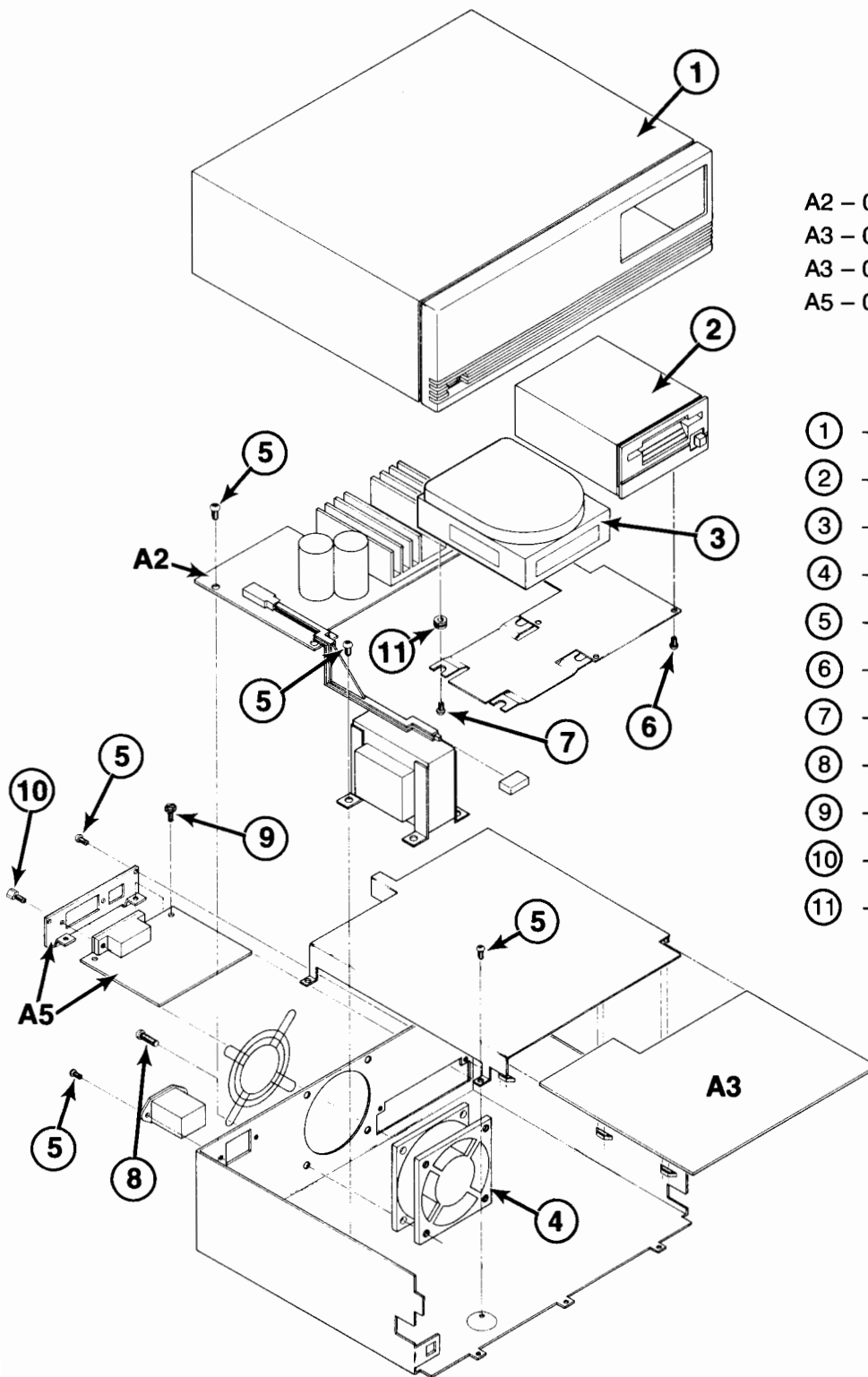

Figure 12-1. Block diagram of the HP 9153A/54A Controller Board (9153-66502) showing the HP-IB Personality Module's relation to the DMA Data Bus.



A2 - 09153-69501

A3 - 09153-69502 (9153A)

A3 - 09154-69502 (9154A)

A5 - 09153-69503

① - 09153-04100

② - 09114-69511 (9153A ONLY)

③ - 09153-69101

④ - 09125-68500

⑤ - 0515-1343

⑥ - 0515-1346

⑦ - 0515-1345

⑧ - 0624-0525

⑨ - 0624-0643

⑩ - 0380-1717

⑪ - 0400-0285

Figure 12-2. HP 9153A/54A Field-Replaceable Assemblies.

Index for HP 9153A / HP 9154A tabbed sections.

A

Adaptec Data Bus 5-3
 addressing, HP-IB controller 5-4
 adjustment, Phase-Lock Loop 7-3
 adjustment, Read Pulse Width 7-3
 adjustment, Write Pulse Width 7-3
 adjustments, flexible disc drive 7-3
 adjustments, preparation for 7-3
 adjustments, Winchester drive 7-3

B

Buffer Controller, data transfers 5-4
 Buffer Ram 5-4

C

capacity, Winchester 3-8
 cleaning flexible disc head 4-3
 configuration of standard drive unit 3-4
 configuration switches 3-6
 Controller PCA 3-6
 controller, common 5-3
 customer responsibility 2-3

D

data transfer buffering 5-4
 devices, maximum number 3-3
 diagnostic test mode, by grounding test point 8-4
 disc access LED, when removing disc 3-4
 disc care, flexible disc 4-3
 disc compatibility 3-6
 disc usage, daily basis 3-6
 disc, interleaves 3-7
 discs, recommended usage 3-6
 DMA Data Bus 5-3,5-4
 DMA transfers 5-3

Drive Select Switch 6-5
 drive, removal 6-4
 dust and dirt, reduction of disc/drive life 2-3

E

ECC check 3-8
 ECC circuitry 5-4
 environmental ranges 1-5
 equipment supplied 1-6
 excessive read errors, needs head cleaning 4-3
 exchange assemblies 1-6
 "exchange only" disc usage 3-6
 Exchange Program 8-3

F

fault indications during power-on checks 8-5
 fault LED, failure indication 8-4
 fault LED, on continuously 8-4
 fault LED, test pass indication 8-5
 Field-Replaceable Units 8-3
 flexible disc drive adjustments 7-3
 flexible disc, capacity 1-3
 flexible disc, formatted capacity 5-3
 flexible disc, sector density 5-3
 flexible disc, sector read 5-4
 Floppy Disk Controller, as interface 5-4
 Floppy Disk Controller 5-4
 Front Panel control indicators 8-8
 fuse, included 3-5
 fuses, ratings 3-5

H

handshaking, HP-IB controller 5-4
 Hard (Winchester) Disc Controller 5-4
 Hard Disc Controller, ECC circuitry 5-4
 Hard Disc Controller 5-4

INDEX

9153A
9154A

head cleaning disc	4-3
head cleaning kit	4-3
HP 9153A, front view	1-3
HP 9154A, front view	1-3
HP media	3-4
HP-IB address switch, selftest selection	8-5
HP-IB Address Switch	3-7
HP-IB address, selecting	3-7
HP-IB cables, distribution	3-3
HP-IB cables, lengths	3-3
HP-IB cables, total length	3-3
HP-IB Controller	5-4
HP-IB Interface Module	3-5

I

improper media	3-4
"Initiate Diagnostic" command.	8-4
installation.	3-3

J

J5 connector assignments	8-3
------------------------------------	-----

L

LED, fault	3-8
LED, on line (disc access).	3-8

M

manual execution of selftests	8-5
manual selftests available	8-7
Microprocessor Data Bus.	5-3
microprocessor, as bus arbiter	5-3
microprocessor, as master controller	5-3
microprocessor, external rate	5-3
microprocessor, handles movement of data	5-3
microprocessor, internal rate.	5-3
motor speed, outside tolerance	3-5

O

operating temperature range	2-3
---------------------------------------	-----

P

parallel polling, HP-IB Controller	5-4
performance characteristics	1-4
Personality Module	1-3
Personality Modules available	1-3
Phase-Lock Loop adjustment	7-3
Phase-Lock Loop	5-4
physical characteristics	1-5
piggybacking HP-IB connectors	3-3
ports	5-3
power requirements	1-5
Power Supply assembly	8-3
power supply voltages	8-3
power-on selftest	8-4
power-on test sequence	8-4
preparation for troubleshooting	8-3
preparation, site	2-3
preventive maintenance, Winchester	4-3
preventive maintenance, flexible disc	4-3
product description	1-3

R

RAM test, example for running other tests	8-6
RAM test, run first or last.	8-6
Read Pulse Width adjustment	7-5
Read/Write Pulse Width waveform	7-5
removal, Controller PCA.	6-3
removal, Power Supply PCA.	6-4
removal, RFI shield	6-5
removal, top cover	6-3
repair philosophy	8-3
ROM.	5-3

S

selecting selftest, HP-IB Address Switch.	8-5
selftests available for manual execution	8-7
selftests, problems	3-8
selftests	3-8, 8-4
serial number information.	1-6
site preparation	2-3
specifications.	1-4
Subset 80	5-3
support strategy	1-6
SW1 Switch	3-7

T

temperature, needed for adjustments 7-3
 tools, for disassembly/reassembly 6-3
 troubleshooting, preparation for 8-3

U

unit selection at power-on. 8-7

V

Voltage Select Switch, changing setting 3-4
 Voltage Select Switch 3-4
 voltage test points 8-3
 voltage, selection. 3-4
 voltages, power supply 8-3

Volume Configuration Switch 3-7
 Volume Switch, changing setting 3-8
 Volume Switch, meanings 3-7
 volume, single 3-7
 volumes, multiple 3-7

W

Winchester disc drive, capacity 1-3
 Winchester disc test 3-8
 Winchester disc, sector read 5-5
 Winchester drive, formatted capacity 5-3
 Winchester drive, sector density 5-3
 Winchester mechanism, rear view 6-5
 Write Protect Error 3-5
 Write Pulse Width adjustment. 7-5

