

# **HP 9144A 1/4-INCH CARTRIDGE TAPE DRIVE Hardware Support Manual**

Manual part number: 09144-90030

Printed: DECEMBER 1986  
Printed in U.K.

Edition 3  
E1286

## **OPTIONS COVERED**

In addition to the standard model, this manual covers the following options: 150.



HEWLETT-PACKARD  
Filton Road, Stoke Gifford, BRISTOL, U.K.

# Notice

---

The information contained in this document is subject to change without notice.

**HEWLETT-PACKARD MAKES NO WARRANTY OF ANY KIND WITH REGARD TO THIS MATERIAL, INCLUDING, BUT NOT LIMITED TO, THE IMPLIED WARRANTIES OF MERCHANTABILITY AND FITNESS FOR A PARTICULAR PURPOSE.** HEWLETT-PACKARD shall not be liable for errors contained herein or for incidental or consequential damages in connection with the furnishing, performance or use of this material.

HEWLETT-PACKARD assumes no responsibility for the use or reliability of its software on equipment that is not furnished by HEWLETT-PACKARD.

This document contains proprietary information, which is protected by copyright. All rights are reserved. No part of this document may be photocopied, reproduced or translated to another language without the prior written consent of HEWLETT-PACKARD Company.

Copyright © 1986 by HEWLETT-PACKARD LIMITED

## **FOR U.S.A. ONLY**

The Federal Communications Commission (in 47 CFR 15.838) has specified that the following notice be brought to the attention of the users of this product.

### **FEDERAL COMMUNICATIONS COMMISSION RADIO FREQUENCY INTERFERENCE STATEMENT**

Warning: This equipment generates and uses radio frequency energy and if not installed and used properly, that is, in strict accordance with the manufacturer's instructions, may cause interference to radio and television reception. It has been type tested and found to comply with the limits for a Class B computing device in accordance with the specifications in Subpart J of Part 15 of FCC Rules, which are designed to provide reasonable protection against such interference in a residential installation. However, there is no guarantee that interference will not occur in a particular installation. If this equipment does cause interference to radio or television reception, which can be determined by turning the equipment off and on, the user is encouraged to try to correct the interference by one or more of the following measures: re-orient the receiving antenna; relocate the computer with respect to the receiver; move the computer away from the receiver; plug the computer into a different branch circuit. If necessary, the user should consult the dealer or authorized field service representative for additional suggestions. The user may find the following booklet prepared by the Federal Communications Commission helpful: "How to Identify and Resolve Radio-TV Interference Problems". This booklet is available from the U.S. Government Printing Office, Washington, DC 20402. Stock No. 004-000-00345-4.

# Printing History

---

New editions are complete revisions of the manual. Update packages, which are issued between editions, contain additional and replacement pages to be merged into the manual by the customer. The dates on the title page change only when a new edition or a new update is published. No information is incorporated into a reprinting unless it appears as a prior update; the edition does not change when an update is incorporated.

A software code may be printed before the date; this indicates the version level of the software product at the time the manual or update was issued. Many product updates and fixes do not require manual changes and, conversely, manual corrections may be done without accompanying product changes. Therefore, do not expect a one-to-one correspondence between product updates and manual updates.

Edition 1.....	June 1984
Edition 2.....	March 1986
Edition 3.....	December 1986

# Safety Considerations

---

**GENERAL** - This product and related documentation must be reviewed for familiarization with safety markings and instructions before operation.

## SAFETY SYMBOLS



Instruction manual symbol: the product will be marked with this symbol when it is necessary for the user to refer to the instruction manual in order to protect the product against damage.



Indicates hazardous voltages.



Indicates earth (ground) terminal.

### **WARNING**

The **WARNING** sign denotes a hazard. It calls attention to a procedure or practice that, if not correctly performed or adhered to, could result in personal injury. Do not proceed beyond a **WARNING** sign until the indicated conditions are fully understood and met.

### **CAUTION**

The **CAUTION** sign denotes a hazard. It calls attention to an operating procedure or practice that, if not correctly performed or adhered to, could result in damage to or destruction of part or all of the product. Do not proceed beyond a **CAUTION** sign until the indicated conditions are fully understood and met.

**SAFETY EARTH GROUND** - This is a safety class I product and is provided with a protective earthing terminal. An uninterruptible safety earth ground must be provided from the main power

source to the product input wiring terminals, power cord, or supplied power cord set. Whenever it is likely that the protection has been impaired, the product must be made inoperative and be secured against any unintended operation.

**BEFORE APPLYING POWER** - Verify that the product is configured to match the available main power source according to the input power configuration instructions provided in this manual.

If this product is to be operated with an autotransformer make sure that the common terminal is connected to the earth terminal of the main power source.

## SERVICING

### **WARNING**

Any servicing, adjustment, maintenance, or repair of this product must be performed only by service-trained personnel.

Adjustments described in this manual may be performed with power supplied to the product while protective covers are removed. Energy available at many points may, if contacted, result in personal injury.

Capacitors inside this product may still be charged after the product has been disconnected from the main power source.

To avoid a fire hazard, fuses with the proper current rating and of the specified type (normal blow, time delay, etc.) must be used for replacement. To install or remove a fuse, first disconnect the power cord from the device. Then, using a small flat-bladed screw driver, turn the fuseholder cap counterclockwise until the cap releases. Install either end of a properly rated fuse into the cap. Next, insert the fuse and fuseholder cap into the fuseholder by pressing the cap inward and then turning it clockwise until it locks in place.

# Contents

---

<b>Chapter 1</b>	<b>Page</b>
<b>Product Information</b>	<b>1-1</b>
General Description .....	1-1
Options .....	1-1
Accessories Supplied .....	1-2
Accessories Available .....	1-2
Performance Specification .....	1-2
Data Capacity (formatted).....	1-2
Data Transfer Rate .....	1-2
Access Time .....	1-2
Recording Parameters .....	1-2
Hard Error Rate .....	1-2
Serial Number Information.....	1-2
Test Equipment and Special Tools.....	1-3
Host Support.....	1-3
Support Strategy .....	1-4
<b>Chapter 2</b>	<b>Page</b>
<b>Site Preparation and Requirements</b>	<b>2-1</b>
Electrical Specifications .....	2-1
Environmental Specifications.....	2-1
Physical Specifications.....	2-1
<b>Chapter 3</b>	<b>Page</b>
<b>Installation and Configuration</b>	<b>3-1</b>
Unpacking and Inspection.....	3-1
Repacking.....	3-1
Storage.....	3-3
Line Voltage and Fusing.....	3-3
Mounting Instructions .....	3-3
Interconnections.....	3-3
Switch Settings.....	3-6
User Information/Operation.....	3-7
Product Self Test Procedures.....	3-7

## Contents (continued)

---

<b>Chapter 4</b>	<b>Page</b>
<b>Preventive Maintenance</b>	4-1
Cartridge Tape Guidelines.....	4-1
Cleaning the Tape Drive.....	4-2
Cleaning Cartridge Use.....	4-3
<b>Chapter 5</b>	<b>Page</b>
<b>Functional Description</b>	5-1
System Overview.....	5-1
Host Dependent Controller Circuit.....	5-2
Device Dependent Controller Circuitry.....	5-8
Read/Write/Servo Circuitry and Mechanism.....	5-12
Power Supply Unit.....	5-16
Cartridge Tape Layout.....	5-17
<b>Chapter 6</b>	<b>Page</b>
<b>Removal and Replacement</b>	6-1
Safety Considerations.....	6-1
Electrostatic Discharge Considerations.....	6-2
Required Tools/Equipment.....	6-2
Repair Environment.....	6-2
Disassembly and Reassembly.....	6-3
Top Shroud.....	6-4
Front Panel Assembly.....	6-4
Front Panel PCA.....	6-5
Unload Button.....	6-5
LED Window.....	6-6
Front Panel Cable.....	6-6
Power Supply Unit.....	6-7
Drive Electronics PCA.....	6-7
EPROMs.....	6-8
Drive Mechanism.....	6-8
Fan.....	6-9
Capstan Motor and Tachometer.....	6-9

**Chapter 7** **Page**  
**Adjustments** 7-1

There are no adjustable parts in the HP 9144A Tape Drive

**Chapter 8** **Page**  
**Troubleshooting and Diagnostics** 8-1

Troubleshooting Strategy .....	8-1
Minimum Configuration.....	8-1
Troubleshooting Procedures.....	8-1
Error Codes.....	8-3
Initiating Diagnostics from a Host Computer .....	8-10

**Chapter 9** **Page**  
**Replaceable Parts** 9-1

Replaceable Parts Information .....	9-1
Ordering Information.....	9-1
Illustrated Parts Breakout.....	9-1
Exchange Assemblies.....	9-1
Field Replaceable Parts List .....	9-2
Coded List of Manufacturers.....	9-2
Abbreviations List .....	9-2

**Chapter 10** **Page**  
**Reference Material** 10-1

Other Manuals.....	10-1
Channel Interface.....	10-1
CS/80 Instruction Set .....	10-1
Transaction Structure.....	10-1
Real-Time Commands .....	10-1
Complementary Commands .....	10-1
General Purpose Commands.....	10-2
Diagnostic Commands .....	10-2
Transparent Messages.....	10-2
Hewlett-Packard Interface Bus.....	10-19
HP-IB Communications.....	10-22
Channel Management.....	10-23
Parallel Poll.....	10-23

**Contents (continued)**

---

Universal Device Clear ..... 10-23  
Message Structure..... 10-23

**Chapter 11** **Page**  
**Product History** 11-1

5 PCA Version.....11-1  
4 PCA Version..... 11-15  
3 PCA Version..... 11-29  
2 PCA Version..... 11-43

**Chapter 12** **Page**  
**Diagrams** 12-1

All diagrams are distributed throughout the text.



# Figures and Tables

---

Figure or Table	Page
Figure 1-1. The Serial Number Label .....	1-3
Figure 1-3. Host Support .....	1-3
Figure 3-1. The Tape Drive, as shipped .....	3-1
Figure 3-2. Interconnections to Host and to Power .....	3-3
Figure 3-3. Available Power Cords .....	3-5
Figure 3-4. The Front Panel .....	3-6
Figure 3-5. The Rear Panel .....	3-6
Figure 3-6. HP-IB Address Setting .....	3-7
Figure 4-1. Depressing the cartridge-in switch .....	4-3
Figure 4-2. Wiping the Capstan .....	4-3
Figure 4-3. Wiping the Head .....	4-4
Figure 5-1. Overview of the HP 35401A Tape Drive .....	5-1
Figure 5-2. Location of Major Electronic Assemblies .....	5-2
Figure 5-3. Cabling Diagram (sheet 1 of 2) .....	5-3
Figure 5-3. Cabling Diagram (sheet 2 of 2) .....	5-4
Figure 5-4. Host Dependent Controller Schematic .....	5-5
Figure 5-5. Device Dependent Controller Schematic .....	5-8
Figure 5-6. Servo Schematic .....	5-12
Figure 5-7. Read/Write Schematic .....	5-15
Figure 5-8. Blocks and Headers .....	5-17
Figure 5-9. Tape Head .....	5-18
Figure 5-10. Data layout on tape .....	5-18
Figure 6-1. Order of Disassembly .....	6-3
Figure 8-1. Self-Test Sequence Flowchart .....	8-2
Figure 9-1. HP 9144A Exploded View (sheet 1 of 2) .....	9-3
Figure 9-1. HP 9144A Exploded View (sheet 2 of 2) .....	9-4
Figure 10-1. Transaction Structure .....	10-20
Figure 10-2. Hewlett-Packard Interface Bus Signal Lines .....	10-21
Figure 11-1. Location of PCAs (5 PCA version) .....	11-2
Figure 11-2. The HDC PCA (5 PCA version) .....	11-3
Figure 11-3. The DDC PCAs (5 PCA version) .....	11-3
Figure 11-4. The R/W PCA (5 PCA version) .....	11-4
Figure 11-5. The Servo PCA (5 PCA version) .....	11-4
Figure 11-6. Power Cabling (5 PCA version) .....	11-5
Figure 11-7. Drive Mechanism cabling (5 PCA version) .....	11-6
Figure 11-8. Signal Cabling (5 PCA version) .....	11-7
Figure 11-9. Order of Disassembly (5 PCA Version) .....	11-8
Figure 11-10. Location of PCAs (4 PCA version) .....	11-16
Figure 11-11. The HDC PCA (4 PCA version) .....	11-17
Figure 11-12. The DDC PCA (4 PCA version) .....	11-17
Figure 11-13. The R/W PCA (4 PCA version) .....	11-18
Figure 11-14. The Servo PCA (4 PCA version) .....	11-18
Figure 11-15. Power Cabling (4 PCA version) .....	11-19
Figure 11-16. Drive Mechanism cabling (4 PCA version) .....	11-20
Figure 11-17. Signal Cabling (4 PCA version) .....	11-21
Figure 11-18. Order of Disassembly (4 PCA Version) .....	11-22

## Figures and Tables (continued)

---

Figure 11-19. Location of PCAs (3 PCA version).....	11-30
Figure 11-20. The SBCONT PCA (3 PCA version).....	11-31
Figure 11-21. The R/W PCA (3 PCA version).....	11-31
Figure 11-22. The Servo PCA (3 PCA version).....	11-32
Figure 11-23. Power Cabling (3 PCA version).....	11-33
Figure 11-24. Drive Mechanism cabling (3 PCA version).....	11-34
Figure 11-25. Signal Cabling (3 PCA version).....	11-35
Figure 11-26. Order of Disassembly (3 PCA Version).....	11-36
Figure 11-27. Location of PCAs (2 PCA version).....	11-44
Figure 11-28. The SBCONT PCA (2 PCA version).....	11-45
Figure 11-29. The RWS PCA (2 PCA version).....	11-45
Figure 11-30. Power Cabling (2 PCA version).....	11-46
Figure 11-31. Drive Mechanism cabling (2 PCA version).....	11-47
Figure 11-32. Signal Cabling (2 PCA version).....	11-48
Figure 11-33. Order of Disassembly (2 PCA Version).....	11-49
Table 2-1. Electrical Specifications: Power and Heat.....	2-2
Table 2-2. Other Electrical Specifications.....	2-3
Table 2-3. Environmental Specifications.....	2-4
Table 2-4. Physical Specifications.....	2-5
Table 3-1. HP-IB Addresses.....	3-6
Table 8-1. Power Supply Voltages.....	8-2
Table 8-2. Diagnostic/Self-Test Errors (TERRORS).....	8-4
Table 8-3. Run-Time Drive Errors (DERRORS).....	8-6
Table 9-1. Coded List of Manufacturers.....	9-2
Table 9-2. Replaceable Parts.....	9-5
Table 9-3. Abbreviations.....	9-7
Table 10-1. Device Real-Time Command Summary.....	10-3
Table 10-2. Device Complementary Command Summary.....	10-4
Table 10-3. Device General Purpose Command Summary.....	10-8
Table 10-4. Device Diagnostic Command Summary.....	10-11
Table 10-5. Tape Drive Utilities.....	10-12
Table 10-6. HP-IB Definitions.....	10-22
Table 10-7. Universal Command Formats.....	10-22
Table 11-1. Diagnostic/Self-Test Errors (TERRORS) (5 PCA).....	11-9
Table 11-2. Run-Time Drive Errors (DERRORS) (5 PCA).....	11-11
Table 11-3. Diagnostic/Self-Test Errors (TERRORS) (4 PCA).....	11-23
Table 11-4. Run-Time Drive Errors (DERRORS) (4 PCA).....	11-25
Table 11-5. Diagnostic/Self-Test Errors (TERRORS) (3 PCA).....	11-37
Table 11-6. Run-Time Drive Errors (DERRORS) (3 PCA).....	11-39
Table 11-7. Diagnostic/Self-Test Errors (TERRORS) (2 PCA).....	11-50
Table 11-8. Run-Time Drive Errors (DERRORS) (2 PCA).....	11-52

# List of Effective Pages

---

The List of Effective Pages shows the edition or update number of all pages. Within the manual, any page changed since the last edition is indicated by printing the update number on the bottom of the page. Changes are marked with a vertical bar in the margin. If an update is incorporated when an edition is reprinted, these bars are removed. No information is incorporated into a reprinting unless it appears as a prior update. To verify that your manual contains the most current information, check that the version printed at the bottom of the page matches the version listed below for that page.

Effective Pages	Version
all .....	Edition 3

This section contains general information about the HP 9144A 1/4-inch Cartridge Tape Drive, which will be known as the Tape Drive. This information consists of a general description, details of options and accessories, specifications and serial number information. Also included is information about supported equipment, any test equipment and special tools needed, and the product support strategy.

## 1-1. GENERAL DESCRIPTION

The HP 9144A is a 1/4-inch cartridge tape drive which provides backup for systems with a disc

capacity of up to 307 Mbytes. The unit is designed for connection to the Hewlett-Packard Interface Bus (HP-IB),\* and uses the CS/80 Instruction Set (see sections 10-2 to 10-9).

The HP 9144A provides read-while-write capability for data verification, as well as data recovery and auto-sparing. A media monitor is included for data protection which gives a front panel warning when a tape cartridge is nearing the end of its useful life. The data can then be copied onto a new tape and the old cartridge discarded.

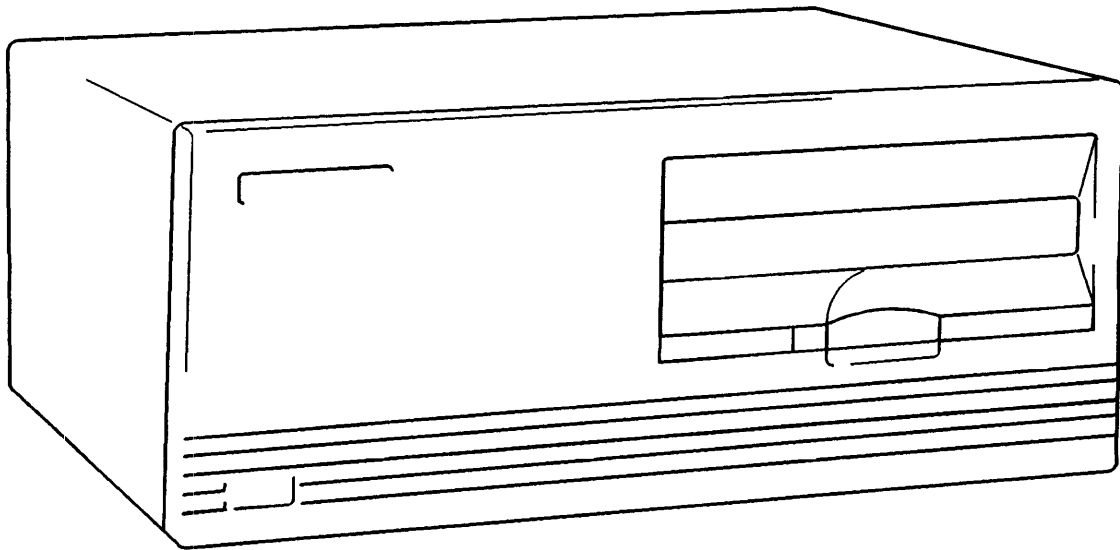

Figure 1-1. The HP 9144A Tape Drive

## 1-2. OPTIONS

In addition to the standard drive, there is an option 150. The drive itself is standard, but in addition to

the usual accessories supplied, there is an extra package. This contains a tape backup utility for the HP 150 Touchscreen and the HP 150 Touchscreen II.

DESIGNED FOR  
**HP-IB**  
SYSTEMS \* Not just IEEE-488, but the hardware, documentation and support that delivers the shortest path to a computer system.

### 1-3. ACCESSORIES SUPPLIED

When the Tape Drive is received, the shipping container should contain the following items:

**Tape Drive:** HP 9144A  
**One 67 Mbyte cartridge**  
**Power cord:** As appropriate (see section 3-6)  
**User's Manual:** 09144-90000  
**Material Safety Data Sheet:** 5957-6473  
**Publicity Material:** 5754-1173  
**2 Spare Fuses:** 2110-0003  
**Cleaning Swabs:** 9300-0767  
**Magnetic Head Cleaning Solution:** 8500-3440

In addition, for the option 150:

**"Read this First" sheet:** 09144-90014  
**Tape backup utility:** 09142-87910 (5957-8750)

### 1-4. ACCESSORIES AVAILABLE

The following accessories may be purchased separately to supplement those which are supplied.

**HP 9144A Hardware Support Manual:**  
09144-90030  
**HP 9144A Customer Engineer Handbook:**  
09144-90039  
**HP-IB Interface Cable**  
  **0.5 meter:** HP 10833D  
  **1.0 meter:** HP 10833A  
  **2.0 meter:** HP 10833B  
  **4.0 meter:** not recommended  
**Package of five 16.7 Mbyte, 150 foot tape cartridges:** HP 88140SC\*  
**Package of five 67.0 Mbyte, 600 foot tape cartridges:** HP 88140LC\*  
**Cleaning Cartridge Kit:** HP 92193E  
**Replenishment Kit for above:** HP 92193P  
**Design Plus mobile mini-rack system cabinet:** HP 92211R  
**Rail Kit for HP 92211R. Contains 4 sets of rails and module locks:** HP 92211S  
**Filler Panel Kit for HP 92211R. Contains twenty 26mm high snap-in panels to fill the space not occupied by equipment:** HP 92211T  
**19-inch Rack Mount Kit:** HP 19500B

### 1-5. PERFORMANCE SPECIFICATION

The Tape Drive has the following performance specifications.

#### 1-6. DATA CAPACITY (FORMATTED)

67.1 Mbytes per "L" cartridge (600 foot)  
16.7 Mbytes per "S" cartridge (150 foot)

#### 1-7. DATA TRANSFER RATE

**Maximum sustained:** 2 Mbytes per minute  
(SYSTEM DEPENDENT)

Maximum sustained transfer rate does not necessarily reflect system throughput which varies depending upon application, file structure and host/tape driver implementation.

**Tape Read/Write Speed:** 60 inches per second  
**Tape Search/Rewind Speed:** 90 inches per second

#### 1-8. ACCESS TIME

**Cartridge load/unload times in drive**  
**Load:** 1 minute 15 seconds (150 foot cartridge)  
          2 minutes 25 seconds (600 foot cartridge)  
**Unload:** 25 seconds (150 foot cartridge)  
          1 minute 35 seconds (600 foot cartridge)

#### 1-9. RECORDING PARAMETERS

**Encoding Technique:** MFM  
(Modified Frequency Modulation)  
**Bit Density:** 10,000 Bits/inch (bpi)

#### 1-10. HARD ERROR RATE

1 in  $10^{11}$  bits transferred

---

\*"C" denotes factory certified tapes.

### 1-11. SERIAL NUMBER INFORMATION



**Figure 1-2. The Serial Number label**

The serial number label consists of a four digit prefix, a letter, and a five digit suffix (0000 E 00000). The first four digits indicate design changes. The letter designates the country in which the unit was manufactured ("E" indicates England). The five digit suffix is a sequential number which increments with each Tape Drive shipped. This label is located below the self-test displays on the rear panel.

In addition to the serial number label on the rear panel, there is a similar label on the tape drive mechanism. The serial numbers should be quoted when ordering parts.

### 1-12. TEST EQUIPMENT AND SPECIAL TOOLS

To repair the unit, you need the Customer Engineer toolkit and a Ball Driver (8710-1570). The HP 85 Service System is required for detailed troubleshooting.

### 1-13. HOST SUPPORT

The HP 9144A Tape Drive is supported on the host systems shown in figure 1-3.

Mainframe	Op. System	Supported	Interface	Cable	Notes	
HP 9000 Series 200 & 300	Basic	Yes	98624A,	HP-IB Must order cable separately. Optional cable length available. (All)	Represents 1 HP-IB load. (All)	
	Pascal	Yes	Internal or			
Series 500	HP-UX	Yes	98625A			
	Basic	Yes	27110A 27110A			
HP 1000 M E F Series	A.85	Yes	12821A		HP-IB Must order cable separately. Optional cable length available. (All)	Does not support system Bootup
	RTE-6/VM					
A Series	RTE A.85	Yes	12009A			
HP 3000 (All)	MPE-V	Yes	30079A			
HP 150B,C/ Touchscreen & Touchscreen II	MS-DOS	Yes				Order Opt. 150

**Figure 1-3. Host Support**  
(see Peripheral Configuration Guide 5953-9472)

## **1-14. SUPPORT STRATEGY**

### **Level of Repair**

The HP 9144A is repaired to the Field Replaceable Assembly (FRA) level. A combination of both non-exchange and exchange parts from the Product Support Division (PrSD) exchange program are used to achieve this.

### **Field Repair Center Strategy**

If the HP 9144A is repaired at a Field Repair Center it should only be to the FRA level.

### **Diagnostics**

See also Section 8. It is the aim of the diagnostic firmware to determine the most suspect FRA

(MSFRA) and display this information on the rear panel. The customer can read the rear panel display and provide the Customer Engineer with information about the failure prior to his visit. This enables the Customer Engineer to take sufficient parts on-site and minimize the repair time. More than one FRA may be indicated; the most suspect FRA being displayed first. Pressing the self-test results button on the rear panel cycles through the remainder of the indicated failures.

To aid troubleshooting a module has been added to the CS/80 External Exerciser diagnostic tape. This diagnostic need only be used when the fault LEDs and the system level exerciser are not adequate to facilitate a repair. (see sections 3-11 and 8-3).

This section contains the information needed to set up a suitable site for the HP 9144A Tape Drive. It includes electrical, environmental and physical specifications, and cable restrictions.

The following paragraphs discuss the requirements for proper operation of the Tape Drive. For detailed site environmental information, refer to the HP publication *CEO Site Prep Handbook* (HP 5958-2370).

## 2-1. ELECTRICAL SPECIFICATIONS

The electrical specifications of the Tape Drive are to be found in Tables 2-1 and 2-2. The unit is a single phase, dual voltage (switch selectable) device which comes supplied with an appropriate power cord and fuse.

### SAFETY

- CSA Certified to CSA 22.2 No. 154
- Meets all applicable safety standards of IEC 380 and IEC 435
- UL listed to UL 114 and UL 478

Units shipped will meet the requirements of the country of destination.

## 2-2. ENVIRONMENTAL SPECIFICATIONS

The HP 9144A Tape Drive is designed to meet the Class B requirements of the HP Corporate Environmental Specification. However, the conditions under which the Tape Drive will operate are limited to those allowed for the media. These limitations are:

### Temperature:

**Operating:** +5°C to +40°C (41°F to 104°F)

**Non-operating:** -40°C to +45°C (-40°F to 113°F)

**Humidity:** 20% to 80% with maximum wet bulb temperature (non-condensing) not to exceed 26°C (79°F).

Tape Drive Environmental specifications are given in Table 2-3.

Cartridge Tape specifications are given in section 4-1.

## 2-3. PHYSICAL SPECIFICATIONS

Details of the Tape Drive physical specifications are given in Table 2-4.



Product: TAPE DRIVE

No. 9144A

Responsible Division: Computer Peripherals Bristol

Table 2-1. ELECTRICAL SPECIFICATIONS: POWER AND HEAT

INPUT VOLTAGE / FREQUENCY

Nominal	115V, 60Hz or 230V, 50Hz (switch selectable)
Range	90V min to 132V max. 180V min to 264V max. 47Hz to 66Hz

CURRENT, in AMPERES

PHASE A, or 1-PHASE:	Single Phase
Typical Steady-State	115V, 60Hz - 0.8A 230V, 50Hz - 0.5A
Maximum Steady-State	115V, 60Hz - 1.1A 230V, 50Hz - 0.62A

POWER USE, in VOLT-AMPS

Typical	115VA
Maximum	134VA

POWER USE, in WATTS

Typical	60W
Maximum	109W

HEAT GENERATION

Typical:	BTUs/h	204.7
	kcal/h	51.6
Maximum:	BTUs/h	246
	kcal/h	62

Product: TAPE DRIVE

No. 9144A

Table 2-2. OTHER ELECTRICAL SPECIFICATIONS

POWER LINE SUSCEPTIBILITY TO LINE TRANSIENTS

Voltage Transients

% of Nominal  $\pm 10\%$  and  $\pm 30\%$  of 240V

Duration ms 10

Frequency Transients

% of Nominal  $\pm 5\%$  and  $\pm 10\%$

Duration ms 10

Spike Transients

Amplitude volts 1500V

Rise Time 5ns

CIRCUIT BREAKER REQUIRED NO

Product: TAPE DRIVE

No. 9144A

Table 2-3. ENVIRONMENTAL SPECIFICATIONS

AMBIENT TEMPERATURE

OPERATING (media limited):

Minimum

+5°C (41°F)

Maximum

+40°C (104°F)

MEDIA NON-OPERATING:

Minimum

-40°C (-40°F)

Maximum

+45°C (113°F)

DRIVE NON-OPERATING:

Minimum

-40°C (-40°F)

Maximum

+75°C (167°F)

RELATIVE HUMIDITY

OPERATING (no media)

MAX 95% @ +40°C

NON-OPERATING

MAX 90% @ +65°C for 24hrs

ALTITUDE

OPERATING

15 000 feet 4 572m

NON-OPERATING

50 000 feet 15 240m

RADIATED EMI SUSCEPTIBILITY  
(VOLTS/METER @ 14kHz - 1GHz)

Meets FCC "CLASS A"

ESD SUSCEPTIBILITY (VOLTS)

>25kV

Product: TAPE DRIVE

No. 9144A

Table 2-4. PHYSICAL SPECIFICATIONS

CRATED DIMENSIONS AND WEIGHT

HEIGHT		WIDTH		DEPTH		WEIGHT	
mm:	286	mm:	445	mm:	483	kg:	10
in:	11.3	in:	17.5	in:	19	lb:	22

UNCRATED DIMENSIONS AND WEIGHT

HEIGHT		WIDTH		DEPTH		WEIGHT	
mm:	125	mm:	325	mm:	285	kg:	6.8
in:	4.9	in:	12.8	in:	11.2	lb:	15

POWER CABLES (LENGTH, mm - in)

STANDARD	OPTIONAL	CONNECTOR TYPE
1210mm	--x--	Male: See Figure 3-3.
48in	--x--	Female: CEE

HP-IB DEVICE LOADS

SHIPPED LOADS	OPTIONAL RANGE	INTERNAL CABLE LENGTH	HP-IB
1	--x--	--x--	

This section contains information needed for you to set up and check out the Tape Drive.

## 3-1. UNPACKING AND INSPECTION

The HP 9144A should, under normal circumstances, be unpacked by the customer and instructions are included in the User's Manual to this effect. These instructions are repeated here for the benefit of service personnel.

The Tape Drive was carefully inspected before shipment. When the shipment arrives, ensure that the container has been received as specified by the carrier's bill of lading. Inspect the shipping container immediately upon receipt for evidence of mishandling during transit. If it is damaged or water-stained, request that the carrier's agent be present when the container is unpacked.

A list of Hewlett-Packard Sales and Support Offices is provided at the back of this manual.

If the shipping container appears to be in good condition proceed to unpack the Tape Drive.

The shipping container consists of a strong cardboard box and two preformed foam blocks. These are shown in figure 3-1.

To unpack the unit, cut the self-adhesive tape which holds the top flaps of the box together. Open the flaps and remove the accessories packet which is found on top of the Tape Drive.

Lift out the unit, together with the foam packing blocks, by sliding your hands down between the box and the sides of the unit. Hold the Tape Drive under its base.

Having removed the unit from the shipping container, inspect the unit for any mechanical damage that may have occurred during shipment.

The packaging also contains the accessories supplied with the unit, in a packet on top of the Tape Drive. Ensure that the equipment supplied

complies with the Packing List and that this agrees with the Purchase Order. A list of the contents of the shipping container is given in section 1-3. Having unpacked the Tape Drive it is worth keeping the shipping container and packing materials for future use.

If any items are incorrect or missing, please accompany all enquiries with the following information:

- Original order number or unit serial number
- Receiving address

## 3-2. REPACKING

If, for any reason, the Tape Drive is to be returned to Hewlett Packard it should be sent back in its original packaging.

### REPACKING INSTRUCTIONS

- Place the tape drive in its polythene bag.
- Store the head cleaning solution bottle in the hole provided in the foam packing.
- With the unit resting on its side, place the packing foam over one side, with the cut-out section facing the top of the unit.
- Turn the unit over and put packing foam on the other side in the same way.
- Slot the tape cartridge in the cutout between the packing foam and the tape drive.
- Holding the packing foam in position on the tape drive, slide the items into the box.
- Store the accessories on top of the tape drive in the packet provided.
- Seal the box for carriage.

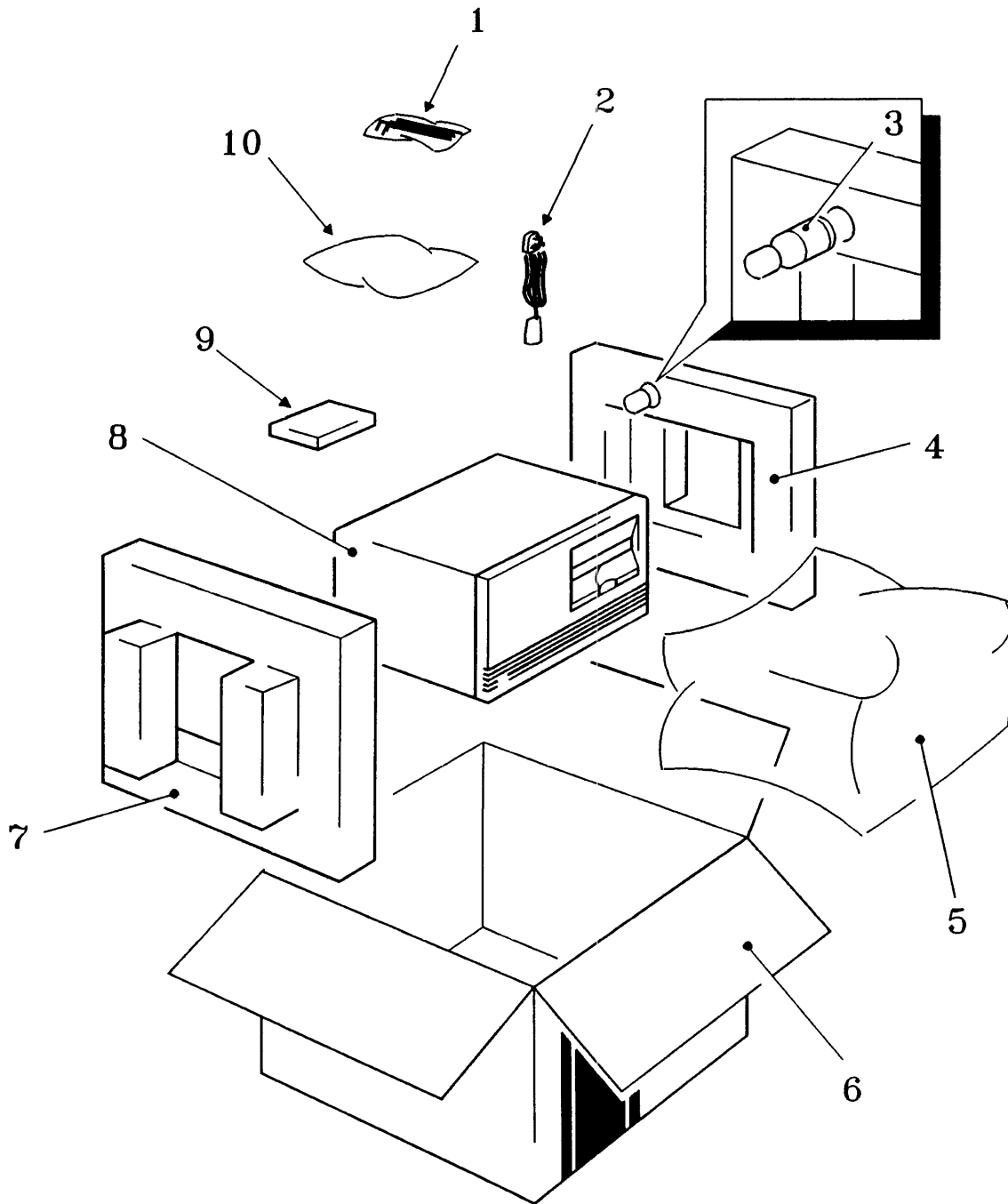

- |                           |                           |
|---------------------------|---------------------------|
| 1.....Cleaning swabs      | 6.....Packing box         |
| 2.....AC LINE Cord        | 7.....Packing foam        |
| 3.....Head Cleaning Fluid | 8.....Tape Drive          |
| 4.....Packing foam        | 9.....Tape cartridge      |
| 5.....Polythene bag       | 10.....Accessories packet |

Figure 3-1. The Tape Drive, as shipped

### 3-3. STORAGE

If the Tape Drive is not to be used for extended periods, its life will be prolonged by storing it in its shipping container in a cool dry place. Select the storage site considering the non-operating environmental limits set out in section 2-2.

### 3-4. LINE VOLTAGE AND FUSING

The voltage select switch on the rear panel must be set to the appropriate nominal line voltage for the area in which the Tape Drive is used. This switch is normally set to the appropriate voltage prior to shipping. The choice is either 115VAC or 230 VAC. Use a 3.0A fuse (normal/fast blow) for either voltage, even though you would expect a higher fuse rating for the lower voltage. The switch-mode supply should only be protected by a fuse of the given rating).

#### WARNING

**Always disconnect the Tape Drive from any AC line before changing fuses.**

The correct fuse to use is a 3.0A, 250VAC, Normal/Fast Blow. This is obtainable as HP Part Number 2110-0003. Refer to the Safety Considerations Page at the front of this manual for instructions on fuse replacement.

### 3-5. MOUNTING INSTRUCTIONS

The HP 9144A is a desktop unit which can also be mounted in a mobile mini-rack system cabinet (HP 92211R). To fit the Tape Drive into the HP 92211R cabinet a mounting rail kit (HP 92211S) is needed, in addition to a filler panel kit (HP 92211T). See section 1-4.

### 3-6. INTERCONNECTIONS

There are only two interconnections for the Tape Drive, the HP-IB connection to the host computer and a connection to the power source. A typical

setup is shown in figure 3-2, where the Tape Drive is connected to an HP 3000 Series 37 computer.

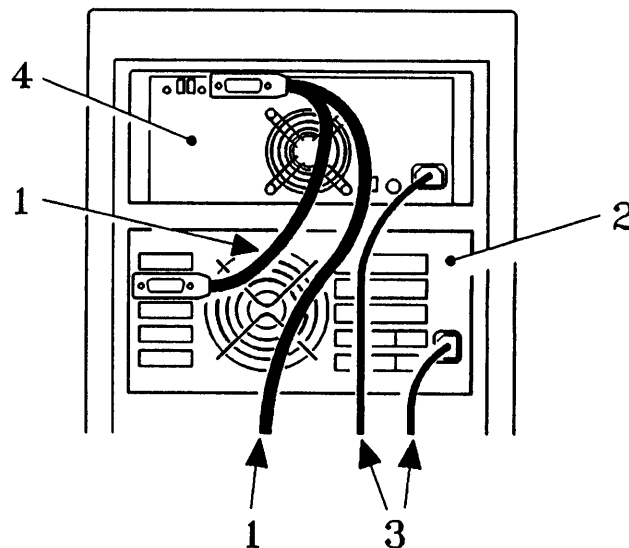

- 1.....HP-IB Cables
- 2.....HP 3000 Series 37 Computer (example)
- 3.....AC LINE Cord
- 4.....HP 9144A Tape Drive

**Figure 3-2. Interconnections to Host and to Power**

A 1 meter or longer cable may be used to connect the Tape Drive to a host computer so long as the following rules are observed:

- All the AC line switches must be turned "OFF" when connecting and disconnecting devices to the system.
- No devices on the HP-IB are to be powered-on or off while there is activity on the bus.
- All devices must be powered-on during any bus transaction with a "high transfer rate" peripheral. When the host is talking to a lower transfer rate peripheral, such as a printer, at least two-thirds of the devices connected to the HP-IB must be powered-on.
- The total length of cable permitted in one bus system must be less than or equal to two meters multiplied by the number of devices connected together.

- The total length of the cable must not exceed 15 meters. The individual cables should be connected together in a linear configuration and the total length must not exceed 15 meters.
- The maximum number of devices that can be interconnected in one bus system is eight.
- Do not stack more than 3 of the connector blocks one on top of another. Large stacks can damage the connector mounting by exerting leverage on it.
- Do not use a screwdriver to tighten the lock screws on the connector blocks, they are designed for tightening by the fingers only. The screwdriver slots are provided to assist removal.

- For best results use only RFI shielded HP-IB cables. (These generally have metal bodied connectors).

The Tape Drive power cable supplied should be the correct type for the country of destination. Those available are shown in figure 3-3.

**WARNING**

**If it is necessary to replace the power cable, the replacement must have a suitable earth conductor. Otherwise an internal failure of the unit could result in a safety hazard.**



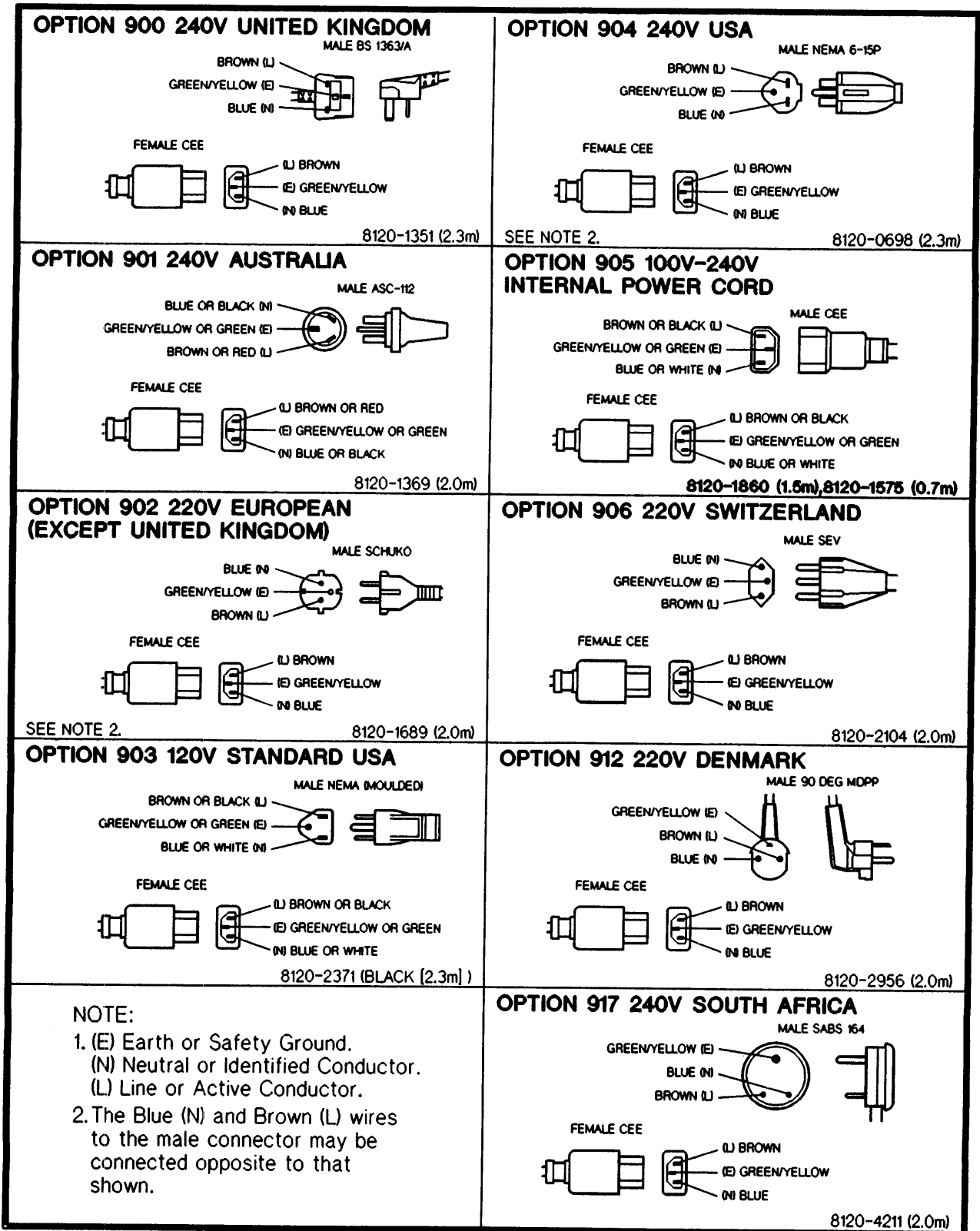
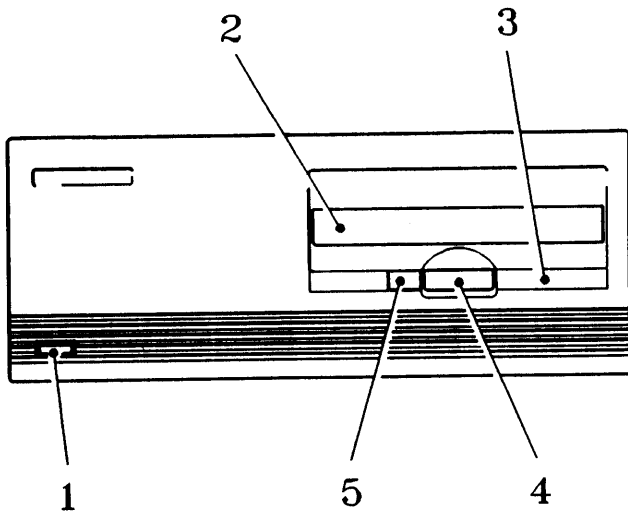

Figure 3-3. Available Power Cords

### 3-7. SWITCH SETTINGS



- 1.....AC LINE Switch
- 2.....Tape Transport
- 3.....Busy Protect Fault Lights
- 4.....EJECT Button
- 5.....Unload Button

Figure 3-4. The Front Panel

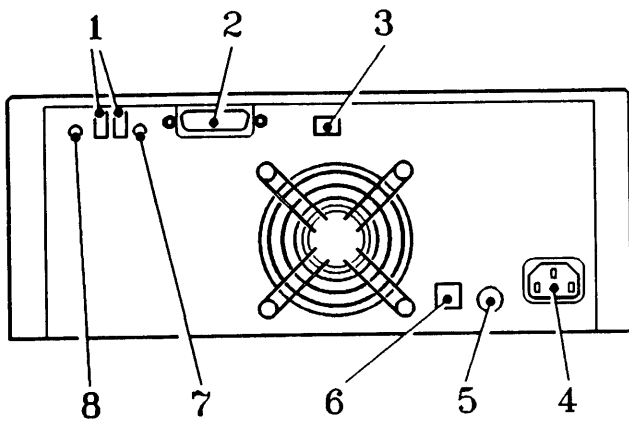

- 1.....Self-test LED displays
- 2.....HP-IB Connector
- 3.....HP-IB Address Switches
- 4.....Power Cable Socket
- 5.....Fuse
- 6.....Voltage Select Switch
- 7.....Initiate Self-test Button
- 8.....Display Self-test Results Button

Figure 3-5. The Rear Panel

The rear panel switches include the Display Results (DR) push-button, Initiate Self-Test push-button, HP-IB Device Address toggle switches and the Voltage Select slide-switch. These are shown in figure 3-5. The Display Results and Initiate Self-Test switches are both miniature push-buttons operated by pressing them with a fine-tipped implement such as a pen or pencil. Their operation and purpose is explained in section 3-11.

The HP-IB address switches are set to give the unit the address 3, by which the host can identify it. This address setting should only be altered if the host is also connected to another device whose address is 3. The normal switch positions for this address are shown in figure 3-6. The miniature toggle switches are operated using a fine-tipped tool, such as a pen or pencil.

The address can be set to any value between 0 and 7 according to table 3-1:

Switch Settings	HP-IB Address
X 4 2 1	
0 0 0	0
0 0 1	1
0 1 0	2
0 1 1	3
1 0 0	4
1 0 1	5
1 1 0	6
1 1 1	7

Table 3-1. HP-IB Addresses

**NOTE**

When setting the HP-IB address switches, disregard any markings on the switch body. Set the switches according to the markings on the rear panel. It does not matter which way the switch marked X is set.

To register the new address, you must either power-cycle the drive or initiate a self-test by pressing the self-test button (see figure 3-5).

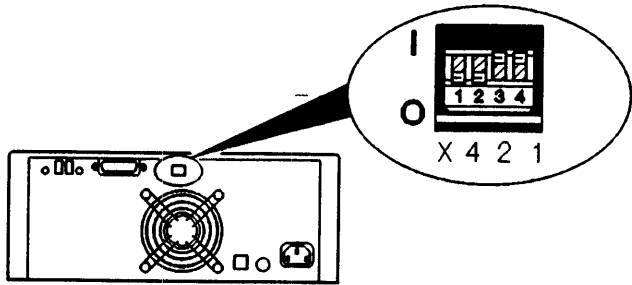

Figure 3-6. HP-IB Address Setting

**WARNING**

The Voltage Select switch should be set to the appropriate line voltage before the Tape Drive is switched on.

The choice is either a nominal 115 VAC or 230 VAC and this is preset to the appropriate voltage for the country of destination. If it is necessary to alter the voltage setting, the slide switch may be operated with a small screwdriver. The switch location is shown in figure 3-5.

**3-8. USER INFORMATION/ OPERATION**

**UNLOAD**

The Unload button () starts a sequence which allows you to remove the cartridge. The sequence takes approximately two minutes for the 600 ft (88140LC) cartridge or about one minute for the 150ft (88140SC) cartridge.

During the unload sequence the  light is on. Towards the end of the sequence the tape drive can produce a clattering sound which lasts for 2 or 3 seconds. This indicates that the read/write head has reached a resting position and has unlocked the cartridge.

After the  light goes out, the tape can be removed by pressing the  button.

**WRITE PROTECT**

is displayed continuously if the cartridge in the drive is write protected. A cartridge can be write-protected by setting its Write-Protect switch.

If  flashes at the end of an unload sequence (when the  light goes out) this means that the tape is nearing the end of its useful life. This is known as the MEDIA MONITOR WARNING.

**FAULT**

is illuminated when a self-test error occurs. Cycling the power causes the light to go out until the error is detected again. The Operator's manual tells the user that if the  light comes on and the self-test display indicates a pass condition, the most likely cause is a bad cartridge or dirty read/write head.

**EJECT**

The  push-button ejects the tape when it is unlocked. The  is always locked until the unload sequence has finished. During an abnormal unload sequence, it can stay locked even when power is shut off. If this happens, apply power again and press  to recommence the unload sequence.

**3-9. PRODUCT SELF TEST PROCEDURES**

The HP 9144A contains self-test routines which test all the major assemblies within the unit. There is a test at power-on, which checks that the major assemblies in the tape drive are working, and a more extensive self-test procedure which repeats the power-on test and performs further tests. The self-tests can be initiated in 3 ways:





- When the tape drive is powered on.
- When the initiate self-test push-button switch on the rear panel (see figure 3-5) is pressed.
- When self-test is initiated from the host controller through the HP-IB interface (see section 8-6).

The self-tests are explained fully in section 8-5.

## SELF-TEST OVERVIEW

The power-on self-test checks that the major assemblies within the tape drive are operable and displays the HP-IB address on the LED displays on the rear panel. If there is a problem, the front panel  light goes on and remains illuminated until another self-test is initiated or the unit is turned off.

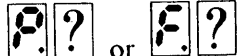
The LED display shows the following sequence during the first second of the self-test routine.

 Off  
 Indicates that the displays are working correctly  
 Indicates that the self-test is proceeding  
 Pass or Fail.  is the HP-IB address of the Tape Drive



The entire self-test takes approximately 7 seconds. After a pass  indication (provided that there is a cartridge in the drive) the load sequence begins. If the self-test was performed without a cartridge in the drive and showed a pass indication, the next step is to insert a tape cartridge.

Embedded within the load sequence is the read/write portion of the self-test. If the cartridge is write-protected, only the read portion is executed. The read and write tests are performed on a section of the tape reserved for testing. If a fault is detected, the  light is turned on and the rear panel LED display shows one of the following.

 Release Denied

Means release has not been granted from the host.

If release is granted from the host, and the test results in a Fail condition:

 Fail on address 

 may be a number from 0 to 7, indicating the device address that the unit is set to.

The next step is to:  
PRESS Display Results

The switch is to be found recessed behind the rear panel to the left of the self-test displays and is operated by pressing it with the tip of a pen or similar object.

### NOTE

While the self-test results are being displayed, communication between the Tape Drive and the host computer is disabled. Once the display returns to either Pass or Fail, communication is re-established.

For Example,  
If test 13 in the self-test routine has failed and A3 and A4 are the most suspect field replaceable assemblies (MSFRAs) in Unit 2, then:

Unit 0 has passed self-test and the display next shows  (don't worry at this stage what the numbers mean, it will become clear when you read section 8-5)

PRESS Display Results

 Unit 2 fails because the display next shows an Assembly number and not a Unit number.

PRESS Display Results

 A3 is an MSFRA

PRESS Display Results

 A4 is the next MSFRA

PRESS Display Results



 Test 13 failed

PRESS Display Results

 Return to fail display

## FAILURE DIAGNOSIS

Depending on the failure, up to two unit numbers can be displayed (as in the example). Unit 0 includes the drive mechanism and electronic assemblies. Unit 2 is the internal controller which includes the Host Dependent Controller.

For each unit that failed, up to 4 MSFRAs can be displayed by pressing the Display Results (DR) switch ( ,  in the example).

After the MSFRAs have been displayed, the failing test number is next shown (  in the example). A list and detailed explanation of these tests is given in section 8-5.

If Unit 0 has a failure the next display after the failed test number will be of the next unit number in the test sequence. If, as in the example, it is Unit 2 which has failed, the next display will revert to

the  symbol with the HP-IB address. This shows that the self-tests are finished.

## OPERATOR INITIATED SELF-TESTS

The self-test routines may be initiated by pressing the Initiate Self-Test push-button on the rear panel. This can be done at any time but the self-test does not begin until the drive has completed any current tasks. The self-test routines are exactly the same as those initiated at power-on.

## HOST INITIATED SELF-TESTS

The host initiated self-tests are carried out by issuing the CS/80 command `Initiate Diagnostic`. This method has the flexibility of initiating individual tests or executing the entire test.

Details of the individual tests and their results are given in section 8-5.

The only preventive maintenance involved with the Tape Drive is concerned with taking care of the cartridge tapes and using a head cleaning cartridge.

## 4-1. CARTRIDGE TAPE GUIDELINES

The cartridge tapes used with the HP 9144A Tape Drive provide a compact and portable storage medium. For this reason, they may be exposed to rapid changes in environmental conditions.

The guidelines given here are recommended in order that the Tape Drive should continue to perform in a highly reliable manner, and that confidence may be placed in a high standard of data integrity.

### CARTRIDGE SPECIFICATIONS

The ANSI X3.55 - 1982 specification applies to the tape cartridges used with the HP 9144A. In part, this states:

*"Temperature ... 5°C to 45°C (41°F to 113°F)  
Relative Humidity..... 20% to 80%  
(non-condensing)  
Maximum Wet Bulb Temperature ..... 26°C  
(79°F)*

*The cartridge shall be conditioned by exposure to the operating environment for a time equal to, or greater than, the time away from the operating environment (up to a maximum of 8 hours). If the user of a data cartridge knows or suspects that the cartridge has been exposed to a drop in temperature exceeding 30°F (16.7°C) since last used, it is recommended that the cartridge be rewound one complete cycle on the tape transport before it is used for data interchange."*

This specifies the normal operating limits for cartridges, but does not clarify restrictions applying to changing conditions within those limits.

Hewlett-Packard has tested cartridges in order to determine conditions for reliable data recovery after temperature changes. Stable conditions help to ensure data integrity, but where they do not occur, the following precautions are recommended.

### CARTRIDGE GUIDELINES

The following three conditions refer to changes in the ambient temperature. It is assumed that:

- the cartridges have been stabilized to the temperature of the room before the change; that is, they have been in the room long enough to reach room temperature
- the cartridge is installed in the Tape Drive
- the Tape Drive is switched on
- the temperature does not go outside the specified operating range for the HP 9144A (5°C to 40°C - 41°F to 104°F)

In each case, the ANSI specification requires up to 8 hours stabilization time after the temperature has changed and before the cartridges should be used.

HP's factory tests have explored the stabilization times necessary to ensure excellent performance, and these times are given for each condition.

#### Condition 1: Controlled Temperature Environment

The temperature varies within  $\pm 5^{\circ}\text{C}$  ( $\pm 9^{\circ}\text{F}$ ).

HP's factory tests show that no stabilization is necessary.

#### Condition 2: Moderately Varying Temperature Environment

The temperature variation is between 5°C (9°F) and 16.6°C (30°F).

HP's factory tests show that 35 minutes stabilization is sufficient.

### Condition 3: Extremely Varying Temperature Environment

The temperature varies more than  $\pm 16.6^{\circ}\text{C}$  ( $\pm 30^{\circ}\text{F}$ ) while remaining within the specified range of  $5^{\circ}\text{C}$  to  $40^{\circ}\text{C}$  ( $41^{\circ}\text{F}$  to  $104^{\circ}\text{F}$ ).

HP tests recommend stabilizing for one hour, followed by retensioning the cartridge. Retensioning is achieved by performing a load/unload sequence on the cartridge.

#### CONDITIONS TO BE AVOIDED

- Do not place the Tape Drive in or near the flow of air from a heater or air conditioner. The cycling of the heater or air conditioner can cause data recovery problems.
- Do not place the Tape Drive near a door which is used frequently, and which separates different temperature conditions. If the Tape Drive is placed near an outside door, for example, the blast of hot or cold air when the door is opened can cause data recovery problems.
- Do not leave cartridges in severe temperature conditions for any extended periods. This includes leaving the cartridges in a car standing in the cold overnight or in the sunlight during the day. If this has happened, then before the cartridge is used for data recovery, it should be stabilized for one hour and then retensioned by performing a load/unload sequence.
- Avoid transferring data (reading from or writing to a cartridge) when the temperature is varying by more than  $3^{\circ}\text{C}$  ( $5.5^{\circ}\text{F}$ ) per hour.
- Position the Tape Drive away from all sources of dust. These include frequently used doors, walkways, stacks of supplies that collect dust and smoke-filled rooms.

#### 4-2. CLEANING THE TAPE DRIVE

The read/write head requires regular cleaning. The head must be cleaned each week and after using a

new cartridge for the first time. Also, cleaning is recommended after every 3 to 5 backup operations requiring the use of the 600ft cartridges. *More importantly, the read/write head should be cleaned whenever data errors are experienced.*

The read/write head can be raised for easy cleaning. To do this, switch the unit on, reach inside the access door with a cleaning swab and use it to press the cartridge-in switch (the lower of the micro-switches located on the left side of the cartridge cavity). Depress this switch then release it, causing the read/write head to rise. It may be necessary to depress the switch several times before the read/write head is completely exposed.

If the switch is held down for approximately 4 seconds the load sequence starts. If this happens, turn the drive off to stop the load sequence then turn it back on and start again.

Clean the read/write head as shown in figures 4-1 to 4-3.

#### CLEANING PRECAUTIONS

HP ONLY supports LIQUID FREON TF\* (trichlorotrifluoroethane) for use as a tape path cleaning solvent. Freon TF cuts oil and grease, evaporates quickly, leaves no residue, and will not damage the transport. If using a vendor other than HP, make sure that the cleaning fluid is a high quality (100%) liquid Freon TF. Avoid solutions of Freon TF and other solvents.

#### CAUTION

Do not use cleaner solutions which contain lubricants. They deposit lubricant on the tape head and degrade performance.

Do not use soap and water on the tape path. Soap leaves a thick film and water may damage electronic parts.

Do not use standard hub cleaners or strong alcohol solutions. These solutions damage the tape guides and capstan.

---

\*FREON TF is a registered trademark of the Dupont Corporation.

Do not use aerosol cleaners; even if they are Freon TF. The spray is difficult to control and often contains metallic particles which damage the tape head.

Do not touch the tape. Do not attempt to clean the tape or tape guides within the cartridge.

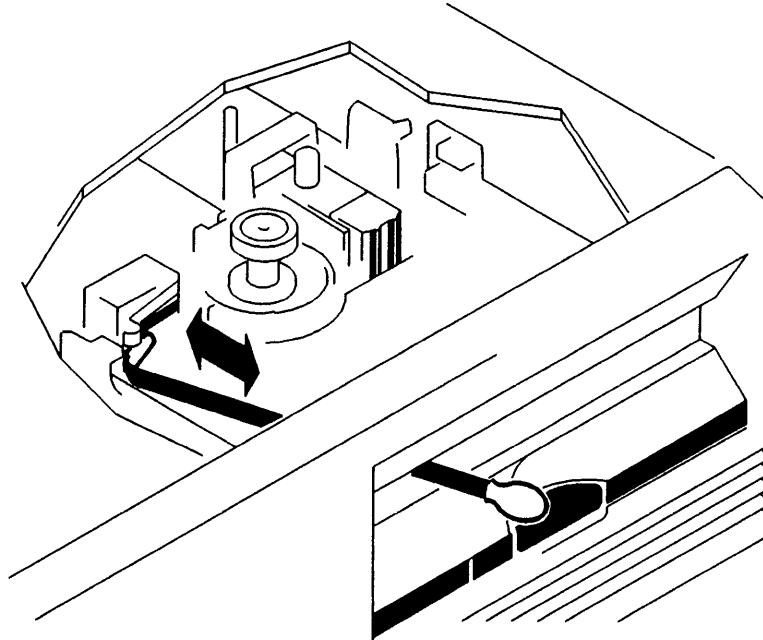

Figure 4-1. Depressing the cartridge-in switch.

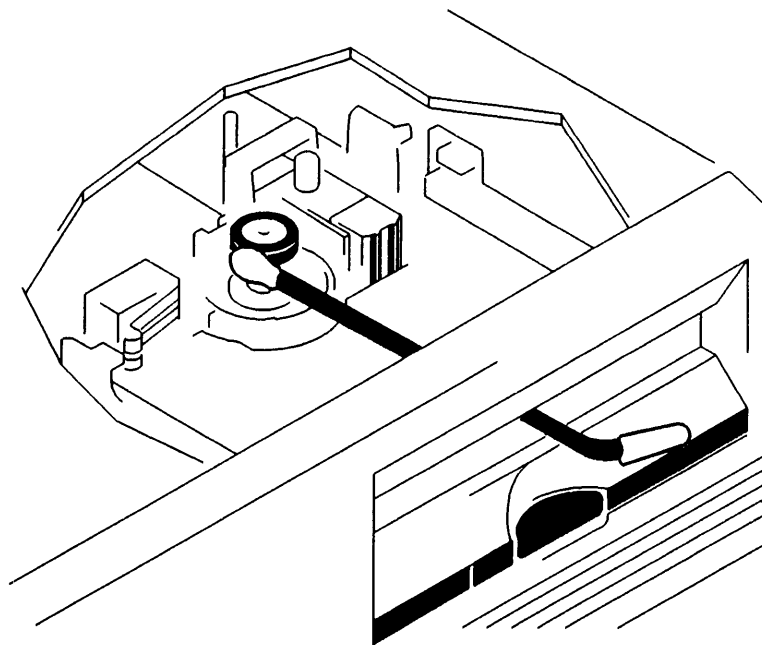

Figure 4-2. Wiping the Capstan.



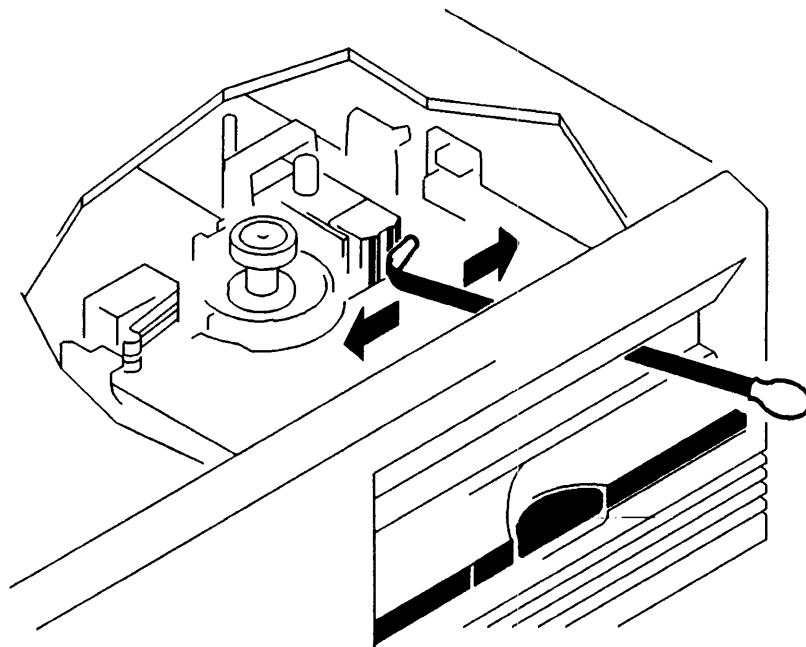

Figure 4-3. Wiping the head.

- Pour a small amount of solvent into a clean container, such as a small UNWAXED paper cup or similar container.

**NOTE**

FREON TF dissolves wax. If a waxed cup is used, the wax will be transferred to the tape path.

- Dip swabs into the container, as needed.
- Applying gentle pressure, clean the following surfaces
  - a. the read/write head (Clean from side to side, NOT up and down)
  - b. capstan (black rubber drive-wheel)

#### 4-2. CLEANING CARTRIDGE USE

Tape head cleaning has been simplified by the introduction of a head cleaning cartridge kit (HP 92193E) including a cleaning cartridge, cleaning fluid and replaceable cleaning pads. The box in which they are shipped also contains printed cleaning instructions. A replenishment kit containing pads and fluid is also available (HP 92192P).

Tape head cleaning is accomplished by moistening the cleaning pad in the cleaning cartridge with the cleaning fluid and inserting the cartridge into the tape drive.

The cleaning pad should be replaced each time the cartridge is used, as an apparently clean, used, pad can contain contaminants.

This section contains a description of the components which make up the HP 9144A Tape Drive. It begins with an overview of the whole system (Section 5-1) and then proceeds to a detailed functional description of the drive electronics and drive mechanism (sections 5-2 to 5-4). It concludes with a description of the power supply followed by a description of the cartridge tape layout (5-6).

## 5-1. SYSTEM OVERVIEW

The HP 9144A Tape Drive contains two major electronic assemblies:

- Drive Electronics PCA (DE PCA)

- Power Supply PCA (PSU PCA)

The Drive Electronics PCA has evolved from four distinct functional circuits. These are shown in the block diagram of figure 5-1 and are described as:

- The Host Dependent Controller (HDC)
- The Device Dependent Controller (DDC)
- The Read/Write Circuitry (R/W)
- The Servo Circuitry (S)

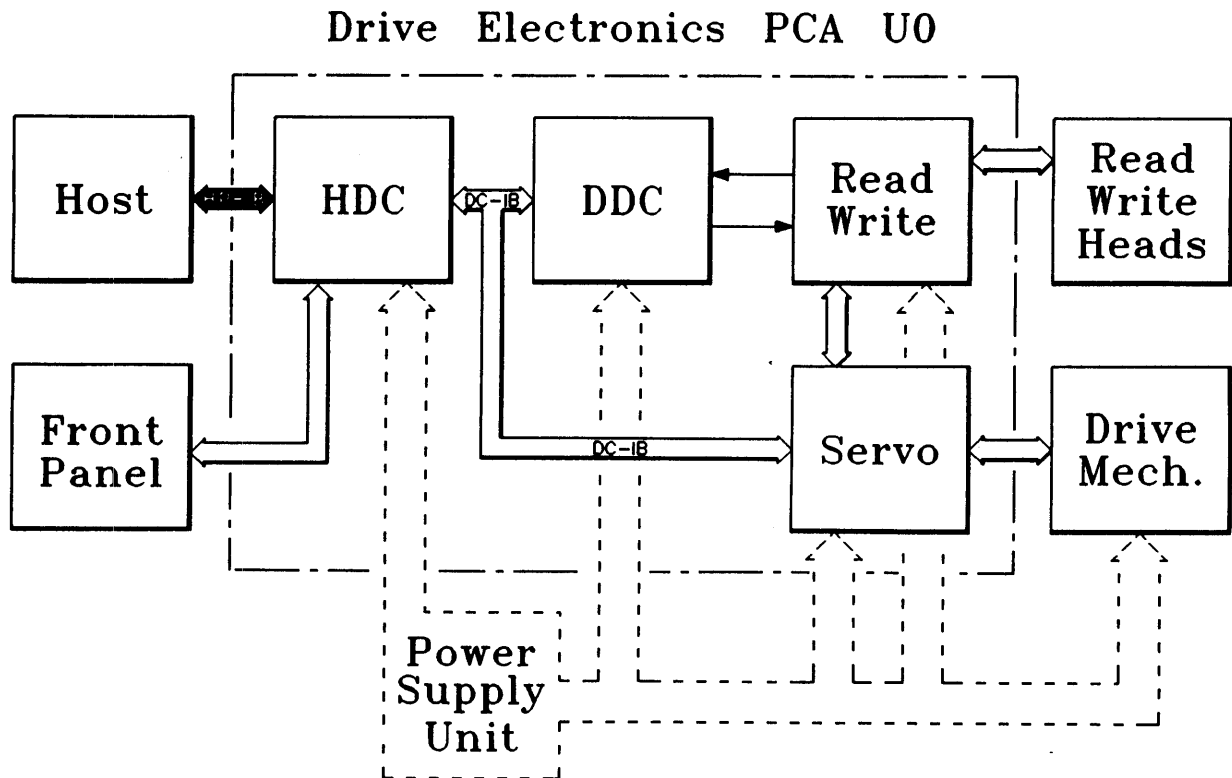

Figure 5-1. Overview of the HP 9144A Tape Drive

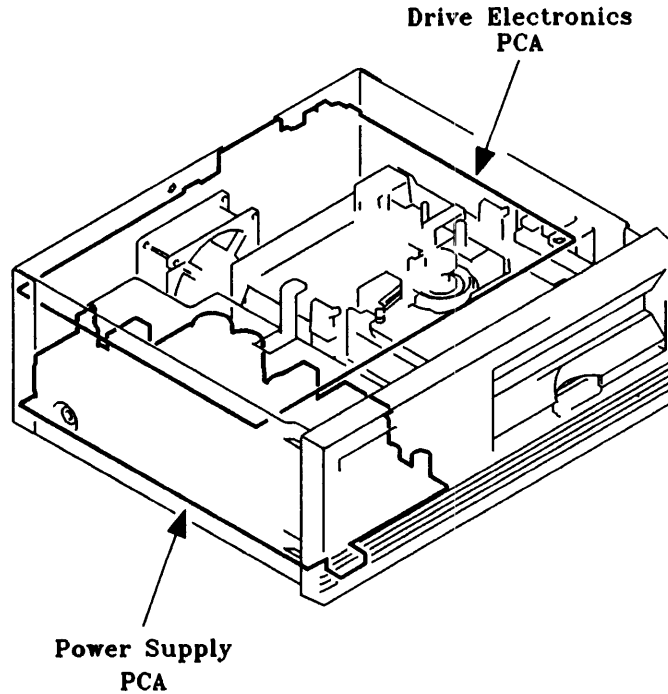

Figure 5-2. Location of Major Electronic Assemblies

The functions of the electronic circuits are outlined in the following overview:

The HDC circuitry:

- Communicates with the Host
- Separates HP-IB commands and data
- Sends data to and from DDC and Host
- Contains Executive firmware
- Contains DDC controlling firmware
- Controls self-test and diagnostics

The DDC circuitry:

- Controls Read/Write and Servo functions
  - Analyses MFM data sent from the Read/Write circuitry
- finds keys
  - checks CRCs
  - performs error correction

- Writes 1k blocks of data to Read/Write circuitry
- generates CRC
  - generates frames 5 and 6 for error correction
  - generates headers for each frame

The read/write circuitry:

- Writes and reads from selected head gaps
- selects head gaps on instruction from the servo microprocessor
  - provides write current
  - amplifies and filters read data from the head gaps
  - detects PVAL, which inhibits write during power-up

The servo circuitry:

- Controls capstan and head-stepper motors
- maintains correct capstan speed and direction

-positions head gaps on required tracks

- Generates power-on reset signal

**POWER SUPPLY UNIT**

- Develops DC operating voltages from AC line

The Front Panel PCA, Fan, Drive Electronics PCA and Power Supply Unit are interconnected according to the following cabling diagram:

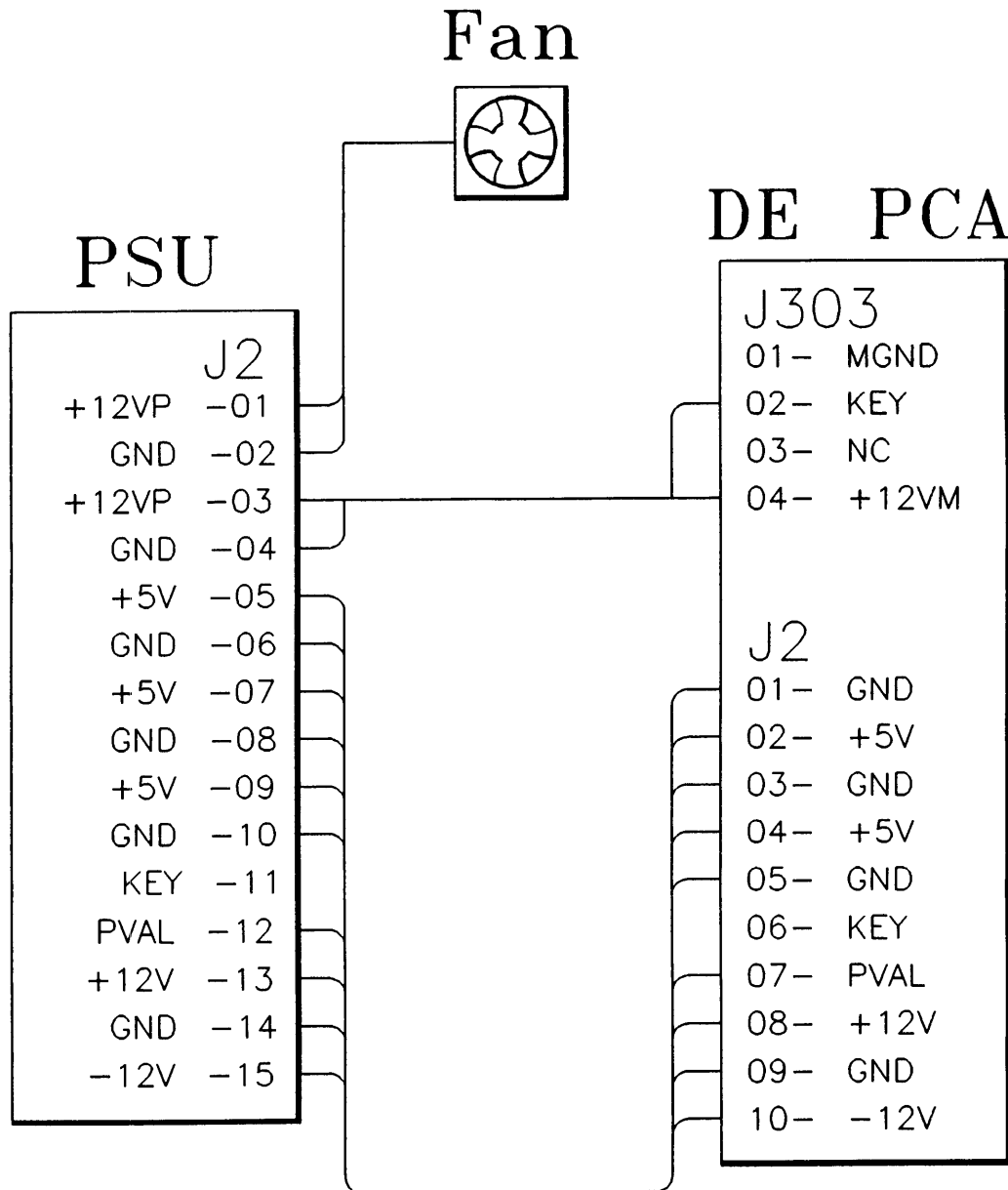

Figure 5-3. Cabling Diagram (Sheet 1 of 2)

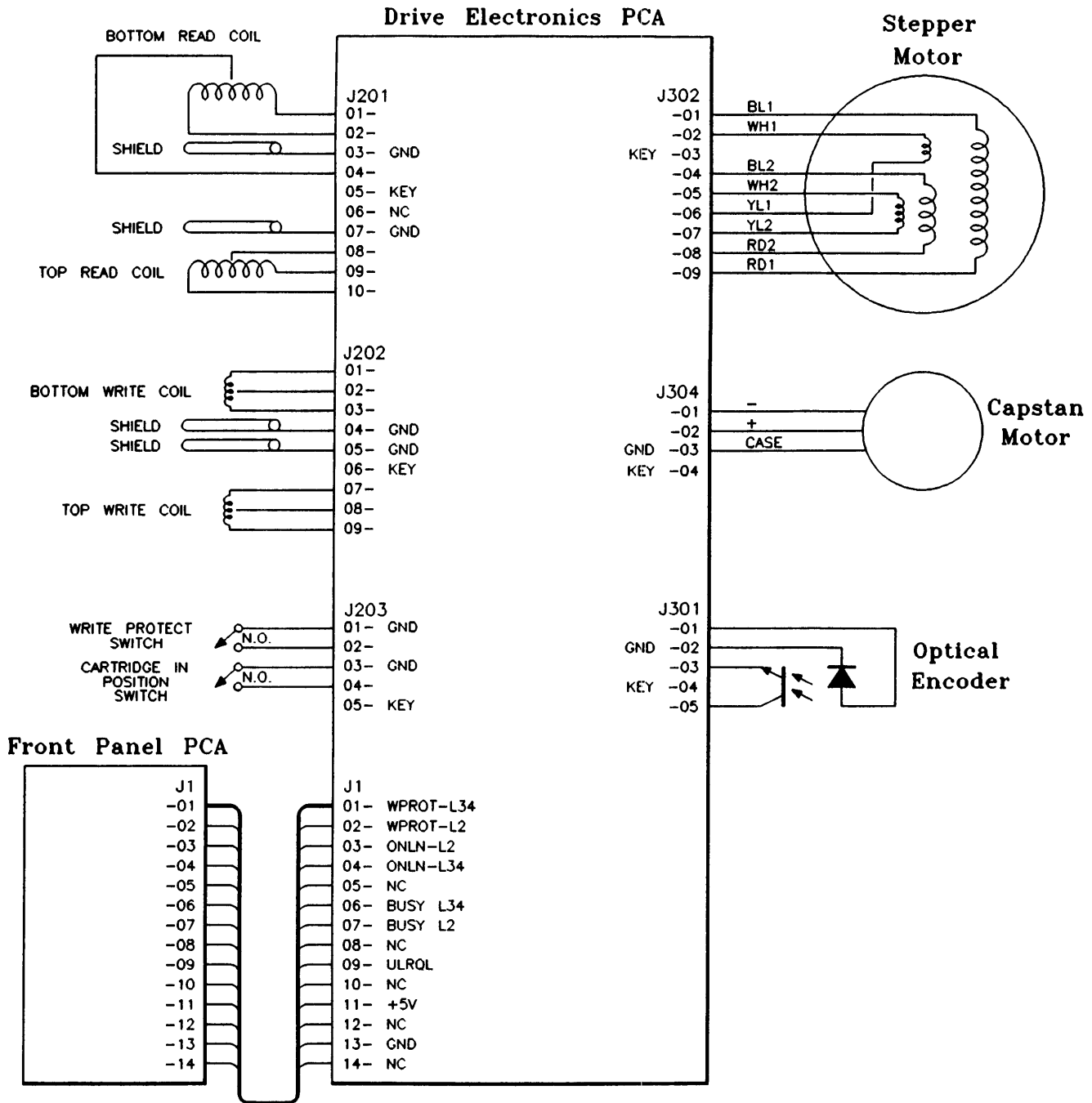

Figure 5-3. Cabling Diagram (Sheet 2 of 2)

## 5-2. HOST DEPENDENT CONTROLLER CIRCUIT

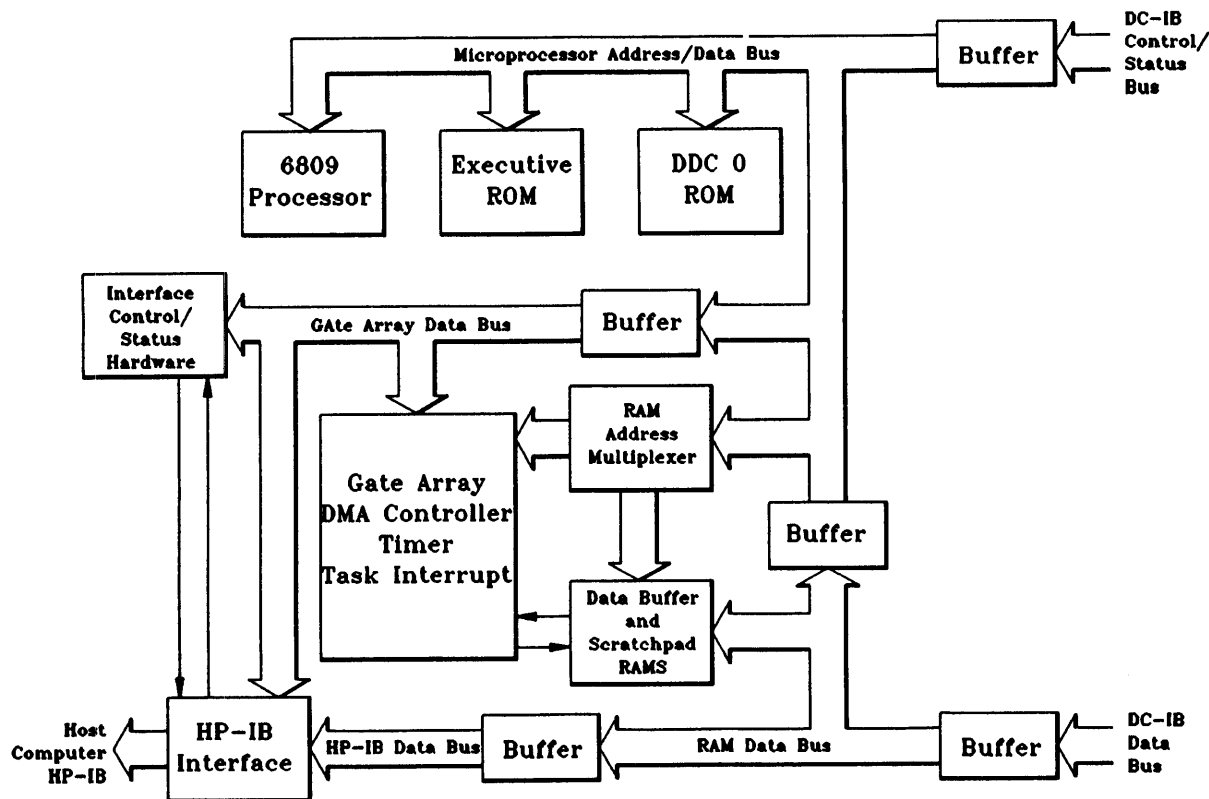

Figure 5-4. Host Dependent Controller Schematic

The Host Dependent Controller (HDC) provides an interface between the host computer and the Device Dependent Controller (DDC) of the Tape Drive. The HDC interface with the host is via the Hewlett-Packard Interface Bus (HP-IB) and with the DDC via the Data/Control Interface Bus (DC-IB).

Host Dependent Controller functions include:

- A host interface via the HP-IB with the software to interpret the commands from the host and respond with status or data.
- Direct memory access (DMA) capability.
- A random access memory (RAM) buffer for data examination for integrity, error correction, and speed matching.

- Firmware and microprocessor for execution of DDC commands and status monitoring.
- Self-test capabilities.

Circuits within the HDC include an HP-IB interface IC, a microprocessor, firmware in EPROM, RAM, a custom-designed DMA gate array IC, and self-test switches and displays.

### THE HP-IB INTERFACE

Interface between the host data channel (HP-IB) and the Tape Drive is provided by a Talker/Listener IC. The IC is accessed by the microprocessor and by the DMA gate array IC input and output processes. The microprocessor must read and write to the various registers in the HP-IB interface IC in order to prepare for data transfers

to and from the host computer. Buffers separate the HP-IB data bus from the RAM data bus.

The HP-IB interface IC implements all of the talker/listener functions of the HP-IB including data transfers, handshake protocol, talker/listener addressing, service request, and serial and parallel polling. HP-IB signals connected to the IC include HP-IB Data I/O Bus DI01-L through DI08-L, End or Identify EOI-L, Data Valid DAV-L, Not Ready for Data NRFD-L, Not Data Accepted NDAC-L, Interface Clear IFC-L, Attention ATL-L, Service Request SRQ-L, and Remote Enable REN-L.

## THE MICROPROCESSOR

The microprocessor provides overall control of all the Tape Drive functions. The HDC employs an internal 8-bit microprocessor. Firmware associated with the microprocessor is contained in two EPROMs: the EXEC EPROM and DDC EPROM. Approximately 72 kbytes of code are kept in the two EPROMs.

## EPROM FIRMWARE

The firmware on the Host Dependent Controller consists of two segments. One segment is the executive operating system (EXEC EPROM) which controls resource allocation (including the DMA gate array IC and the RAM), and the passing of messages and information between the DDC firmware and the Host interface firmware.

The other segment is the control firmware for the DDC. The microprocessor is shared between the DDC and the executive firmware by timesharing, each being accessed by the microprocessor for approximately 500 microseconds. Each set of firmware takes care of its own task, performing whatever function the host or device has requested. Self-test firmware is included in each of the segments. The DDC communicates with the HDC over the DC-IB. This bus contains an 8-bit control/status data bus with appropriate read/write strobes and associated 6-bit control/status address bus, and a completely independent 8-bit read/write data bus with associated strobes.

## RANDOM ACCESS MEMORY (RAM)

The random access memory (RAM) is a temporary storage location for all data transfers. The HDC

contains 16K of RAM on two ICs. The use of RAM is time multiplexed, so that for one half of a microprocessor clock cycle, the microprocessor has access to the RAM. On the other half cycle the DMA gate array IC has access to the RAM.

## DIRECT MEMORY ACCESS (DMA)

Direct memory access is defined as the ability to perform complete memory cycles without the intervention of the HDC microprocessor. The DMA gate array IC is a custom designed integrated circuit which controls data transfers between the host and the RAM. It also transfers self-test status information from the microprocessor to the self-test display. The DMA gate array is set up for either an input to or an output from the RAM. Once activated, the DMA gate array IC performs reads or writes to the RAM completely transparent to the microprocessor.

## SELF TEST

Two momentary contact push-button switches, accessible through openings in the rear panel of the Tape Drive, allow the operator to initiate operation of the internal self-test diagnostic routines. One switch, labeled SELF TEST, initiates the self-test routines. The other switch, labeled DISPLAY RESULTS, causes the self-test results to be displayed on the self-test display. The self-test display is visible through openings in the rear panel between the self-test switches, and comprises two seven-segment LEDs. The display is controlled by the microprocessor and provides a two-digit hexadecimal readout of self-test results, including the defective unit, field replaceable assembly (FRA), and subtest failure number. Information on how to interpret the self-test readout is contained in section 8-5.

## HDC INTERNAL BUS ARCHITECTURE

The internal bus architecture of the HDC is shown in Figure 5-4. and comprises the following buses:

- HP-IB Data Bus
- RAM Data Bus
- Microprocessor Address Bus
- Microprocessor Data Bus

- DMA Gate Array Data Bus
- Data Control Interface Bus (DC-IB)

A description of each bus is given below:

#### HP-IB DATA BUS

The HP-IB Data Bus connects the HP-IB interface IC to the microprocessor and the DMA gate array IC. The microprocessor reads and writes to the various registers in the HP-IB interface IC in order to prepare for data transfers to and from the host computer. Communication between the microprocessor, DMA IC and the HP-IB interface IC passes through the RAM and RAM Data Bus. Buffers separate the HP-IB Data Bus from the RAM Data Bus and permit speed matching between the HP-IB data rate and the DMA gate array IC data transfer rate.

#### RAM DATA BUS

The RAM Data Bus is used for all data transfers between the RAM and the microprocessor, the RAM and the DDC, and the RAM and the HP-IB. The use of the RAM is time multiplexed, so that in one half of the microprocessor clock cycle, the microprocessor has access to the RAM, and in the other half, the DMA gate array IC has access to the RAM.

#### MICROPROCESSOR ADDRESS BUS

The Microprocessor Address Bus is used to point to the next source of instructions or data.

The circuits addressed by the Microprocessor Address Bus include the HP-IB interface IC; RAM (via the address multiplexer), the DMA gate array IC, the EXEC EPROM and the DDC EPROM. The microprocessor can write directly to the DDC via a buffer and the DC-IB Control/Status Address Bus to operate the tape drive.

#### MICROPROCESSOR DATA BUS

The Microprocessor Data Bus interconnects the microprocessor, the EXEC EPROM and the DDC EPROM. The microprocessor RAM exists on a separate bus so that the RAM can be shared by the microprocessor and the DMA gate array IC. The bi-directional data on the Microprocessor Data Bus includes preprogrammed control sequences (algorithms) in EPROM and control/status information from the DDC. The Microprocessor Data Bus is connected to the DDC via a bi-directional buffer and the DC-IB Control/Status Data Bus.

#### DMA GATE ARRAY DATA BUS

The DMA Gate Array Data Bus is used when the microprocessor must read or write to registers in the DMA gate array IC, including the DMA registers and the free running timer used to sequence between Executive and DDC operations.

#### DATA CONTROL INTERFACE BUS (DC-IB)

The Data/Control Interface Bus (DC-IB) is the communication link between the HDC and the DDC. The DC-IB is buffered to both the RAM Data Bus and the Microprocessor Address/Data Bus on the HDC. The DC-IB consists of two independent data buses: a Control/Status Data Bus and a Read/Write Data Bus.

The Control/Status Bus is used to send commands to the DDC or HDC. This bus is used to initiate the transfer of information to or from the recording medium and to interrogate the status of the DDC and its drive mechanism. A Control/Status Address Bus associated with the Control/Status Data Bus provides an addressing capability.

The Read/Write Data Bus is used to pass data between the HDC and the DDC. The Read/Write Data Bus is the path taken by all the data which passes between the host computer and the DDC.



### 5-3. DEVICE DEPENDENT CONTROLLER CIRCUITRY

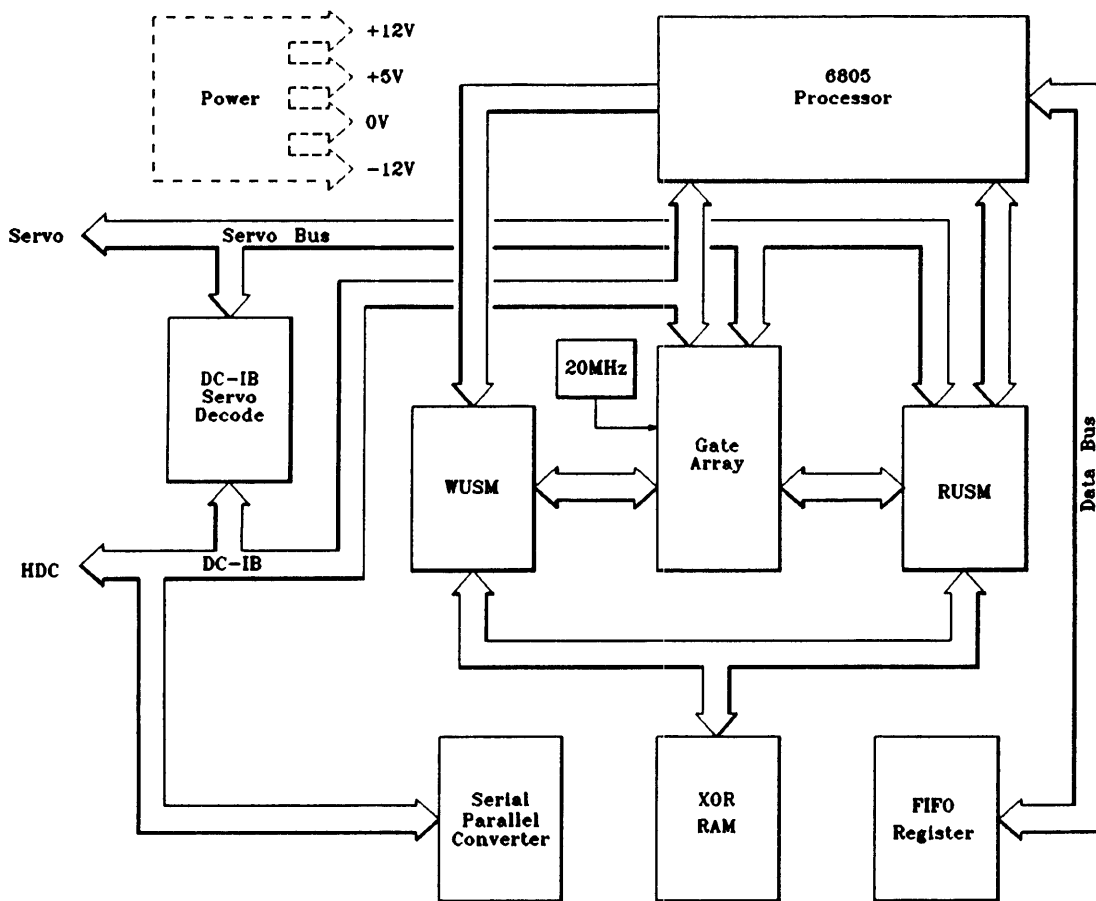

Figure 5-5. Device Dependent Controller Schematic

The Device Dependent Controller performs three main interfacing functions. It interfaces between the HDC, the write state machine and the read state machine. Interfacing is controlled by a 6805 microprocessor resident on the DDC.

#### THE MICROPROCESSOR

The microprocessor on the DDC is responsible for the following functions:

- It receives commands from and reports status to the HDC
- It issues commands to the two state machines
- It monitors status of both state machines

The microprocessor handles low level commands such as READ, WRITE and SEEK. During a write command, 1 kbyte (4 times 256) of user data is passed from the HDC to the DDC. This is a block of data. The HP 9144A handles data in this block (1 kbyte) format. Added to this block of user data are sync bits, headers, CRCs (Cyclic Redundancy Check error detection), and exclusive-OR information stored on the tape. The exclusive-OR information comprises frames 5 and 6 (256 bytes/frame). The added data items are used in data management and data recovery and are all stored on the tape. During a read operation, the DDC sends 1.5 kbytes of data to the HDC. This data is flagged with an error if the CRCs do not match. If an error is detected, the exclusive-OR frame for that data

block is used to rebuild the bad frame. All overhead and error correction are stripped from the data before it is sent back to the host computer.

The microprocessor is designed to handle overlapped commands. This allows the tape drive to function in the streaming mode, which is done in the following manner:

- The HDC tells the DDC (6805) to read a block of data
- While beginning the first read, the HDC tells the DDC to read a second block of data
- The 6805 holds the results of the two status reports providing feedback to the HDC

#### IDENTIFY REGISTER

On the HDC are mounted two replaceable EPROMS; the EXEC EPROM and the DDC EPROM. To ensure that the correct EPROM for the DDC has been inserted, the identify register on the DDC is read by the HDC during initialization and compared with information on its EPROM. An initial switch-on self test error will result if the wrong EPROM is inserted.

#### WRITE STATE MACHINE

The write state machine is responsible for the generation of the WZDATA signal. WZDATA contains a pulse for every flux transition that appears on the tape. The write state machine is under the control of the 6805 through the use of two signals; Write Go (WGO) and self-test Errors (STE).

The Write Go signal tells the state machine to begin its writing sequence. Contained inside the state machine is the definition for the tape format. The format consists of the tape gaps, headers, sync fields, data, and exclusive-OR information. Each of these format items contains a set number of bits and is stored in locations accessible to the state machine. When writing a sync field, zeros are written and a one bit is written for the sync bit. Header data is put into the FIFO (First-In, First-Out register) by the 6805 and clocked out to the tape when the state machine requires header information. User data is obtained from the HDC.

Then the state machine issues DMA requests to obtain user data. Also, exclusive-OR data is obtained from the exclusive-OR RAM for the 5th and 6th frames. All data going to the tape is serialized, precompensated, and processed through the MFM encoder. MFM encoding is accomplished by a section of EPROM resident in the DDC microprocessor.

Once processed, the WZDATA (write data) signal is generated and sent to the Read/Write circuitry. WZDATA contains a negative pulse for every flux transition or flux reversal that is to appear on the tape.

The Self-test Errors signal initiates a self-test mode. This mode checks the CRC generation and the error correction circuitry. With this circuitry operational, the state machine can detect and correct errors caused by the write process using the read-while-write process.

Both state machines use the FIFO buffer, but not at the same time. The write state machine uses the buffer for storing data to be written.

The buffer is cleared only after the read-while-write verifies that the data is correctly written onto the tape. The read state machine uses the buffer data and keys that are read.

#### WRITE PROCESS

The write process involves the use of a serializer and a multiplexer. The serializer latches in an 8-bit word from the HDC. This word is then clocked out using the read-bit clock (RBITC) a bit at a time (serial data). As the last bit is clocked out the serializer issues a DMA request to the HDC for another 8-bit word of data. This serial data becomes the user portion of the WZDATA signal that will eventually be written as frames 1 to 4 on the tape.

The serial data from the serializer is the input data to the multiplexer, exclusive-OR circuitry, and the CRC generator.

The multiplexer selects and gates the proper signals together to create the raw form of the signal WZDATA. The output of the multiplexer (WZDATA) must still be encoded and

compensated. The inputs to the multiplexer are as follows:

- Two hardwire lines:
  - One tied to +5 volts (used to write the sync bit)
  - One tied to ground (used to write the sync field and postamble)
- An input from the FIFO buffer (header information)
- The input from the serializer (frames 1 to 4)
- An input from the CRC generator (CRC field)
- Data from the exclusive-OR RAM (frames 5 and 6)

All the signals listed above are gated through the multiplexer at the proper time. The cycling and counting control comes from the write state machine control. To begin with, the sync field is generated by selecting and gating 47 zeros. This is followed by switching the input to the +5 volts line and outputting one sync bit. The header information follows, comprising 48 bits. This data is placed in the FIFO by the 6805. The next line selected by the multiplexer is the serialized user data from the serializer output (2048 bits). The multiplexer then switches to the CRC generator and writes out 16 bits of CRC data. This is followed by 4 bits of postamble (0s). The next output is the write gap which is 14 clock cycles without a pulse. This is the first frame and is repeated another three times using user data.

For the fifth and sixth frames exclusive-OR data is switched in, in the place of user data. Frame 5 is generated from user data frames 1 and 3, and frame 6 is generated from user data frames 2 and 4. See section 5-7 for tape data storage information.

The output of the multiplexer is encoded into MFM coding. This encoding is a flux transition per clock cycle for each "1" and no transition for a "0".

The data is then precompensated to avoid bit crowding. The precompensation is to one of five

values:  $\pm 12.5\%$ ,  $\pm 6.25\%$ , or  $0\%$ . This output signal (WZDATA) leaves the DDC and goes to the Read/Write circuitry.

The write state machine control is enabled by the 6805 using the WGO (Write Go) signal. This block is a series of counters and outputs to the multiplexer. Control of the multiplexer consists of sorting out when to step through the individual multiplexer inputs. All the bit counting functions are maintained in the write state machine control.

## READ STATE MACHINE

The read state machine continually monitors data read from the tape, searching for BOT and EOT patterns, keys and frames, and determining whether it has found a key or a frame. Also under the control of the 6805, the read state machine issues DMA requests for the read process. If an error condition exists, all error latches are sensed and the status is provided to the 6805.

For a read operation, data processing is the converse of the write state machine. That is, ZDATA is brought in from the Read/Write assembly and decoded. If no error conditions exist the read state machine issues DMA requests to the HDC and transfers data to the HDC. If an error does exist, the read state machine attempts to rebuild the data using the exclusive-OR data in the RAM. All data sent to the HDC is considered good data and to be of a uniform amount (256 bytes of data from each frame with a total of four frames).

If the read state machine is unable to rebuild the frame through the exclusive-OR RAM, the HDC issues retries. If these methods are unable to send good data to the HDC (determined by the HDC), the data is considered unrecoverable.

A verify operation simply checks the CRCs and reports a pass or fail check. The operation does not involve the use of the FIFO buffer. Verify does not issue DMA requests or use the exclusive-OR RAM.

## READ PROCESS

By monitoring the gaps (RGAP), the read state machine control knows the beginning of each frame. As soon as the gap goes away the data separator locks onto the sync field and begins

looking for the sync bit. Once this bit is found, the read state machine control begins the CRC checker and clocking data into the FIFO. This is a count of 48 bits of header information.

After the header comes the user data for frames 1-4 to the serial to parallel converter. User data for frames 5 and 6 is EXCLUSIVE-ORed through the exclusive-OR block to the serial to parallel converter. After counting eight bits the read-state-machine control issues a DMA request to the HDC. The HDC then reads the available 8-bit byte. After the user data the read-state-machine counts another 16 bits and latches the output of the CRC checker. This output is a zero if no error has occurred and a one if there is an error. The CRC codes have the property that given themselves as an input, the result is zero. This error status is provided to the 6805 which in turn passes it on to the HDC on completion of reading an entire block. The input data is now in the next gap and the data separator waits for the next sync field. The 6805 handles each frame independently and keeps track of which frame is being read.

Associated with both state machines is the exclusive-OR RAM. This RAM is used to generate data for the exclusive-OR frames (frame 5 and frame 6) on a write. When the write state machine receives data from the HDC, the data to be written in frames 1 and 3 is used to create exclusive-OR data for frame 5. The data for frame 6 is created from the data to be written in frames 2 and 4.

During a read operation, an entire block of data is read. The read state machine monitors for errors

and dropouts (missing data) in the entire block (frames 1 to 6). If errors are detected the user data is reconstructed as much as possible using the exclusive-OR frames 5 and 6.

#### THE INTERRUPT ARBITER

The 6805 microprocessor is interrupt driven. Because the number of different interrupt requests exceeds the number of lines into the microprocessor, a finite state machine is used as an arbiter to manage which interrupts get priority and to queue the rest. The read state machine interrupts when it has finished processing frame or key header information. The write-state-machine interrupts when it has finished using the FIFO, as when writing a frame header. This informs the 6805 that more information can be put into the FIFO for the next frame. The read-while-write function causes read interrupts during a write process. A tape read generates only read interrupts, while a write generates both write and read (verify) interrupts. This tells the 6805 what state the read or write process is in at all times.

#### CLOCKS

This assembly runs off a 20 MHz clock, which enables the precompensation circuitry to write a bit accurately at a 50 nanosecond increment. The 20 MHz clock is fed directly to the gate array IC which then generates 4 MHz clock pulses for the microprocessor. The gate array IC also generates the precompensation.

### 5-4. READ/WRITE/SERVO CIRCUITRY AND MECHANISM

The Read/Write/Servo circuitry controls all aspects of the tape drive mechanism operation.

This function is divided into two main task areas of tape mechanism control and tape data read/write control.

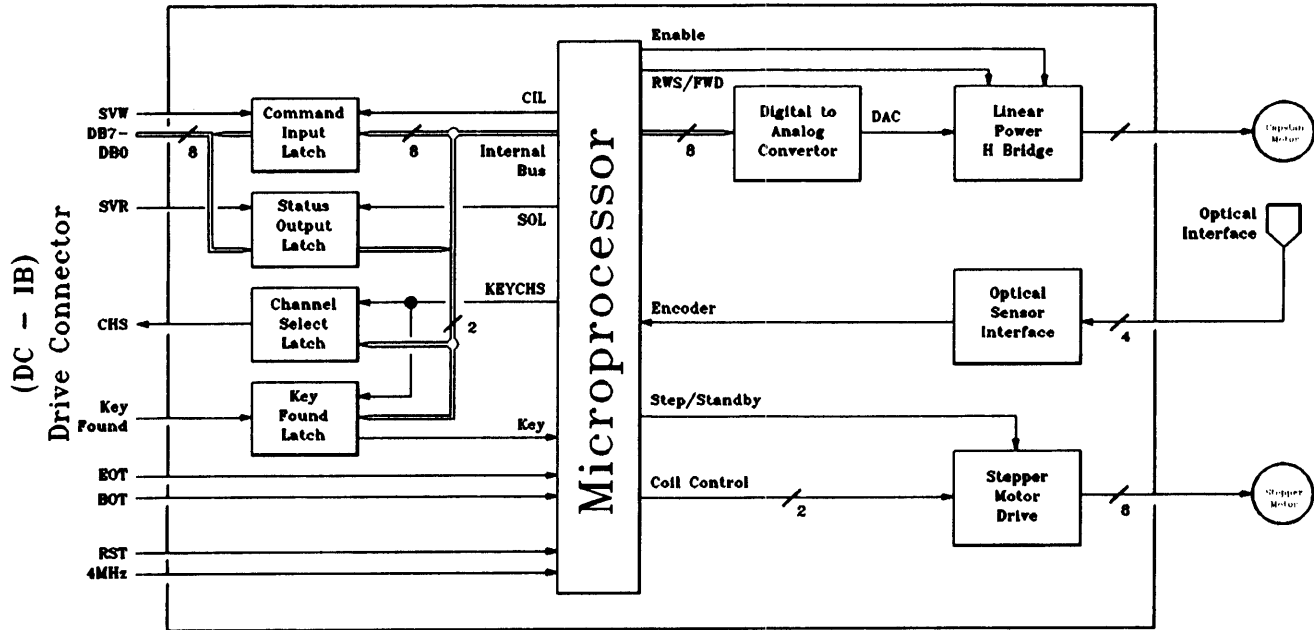

Figure 5-6. Servo Schematic

#### SERVO CONTROL

The servo control part of the assembly consists of two control systems; a tape drive system to control cartridge tape acceleration and speed, and a head positioning system to position the read/write head. These two systems are controlled by a 6805 microprocessor. The tape drive system controls a DC torque motor in a closed loop system; whereas the head positioning system uses both an open or closed loop configuration with a stepper motor. Also, the microprocessor accepts commands from and returns status to the HDC.

The servo control circuitry is also responsible for the selection of the correct gap pair on the read/write head, stopping the tape drive motor upon detection of BOT or EOT, and its diagnostics. The assembly can be divided into four main functional blocks:

- Data/Control Interface Bus (DC-IB)
- Microprocessor

- Capstan Motor and Loop Circuitry
- Head Stepper Motor and Circuitry

#### DATA BUS INTERFACE

The interface with the DC-IB consists of two 74LS374N devices. These are tri-state devices which serve as input and output data latches, being tied together to obtain bi-directional bus communication.

The input data latch receives command and handshake bytes from the HDC. Data is latched from the eight data lines DB0 through DB7 when a positive transition occurs on signal line SVW-L (Servo Write).

The output latch contains the servo status. The contents of the latch are placed onto the eight data lines, DB0 through DB7, when a negative

transition occurs on signal line SVR-L (Servo Read).

#### MICROPROCESSOR

The microprocessor (6805) consists of 112 bytes of RAM, 4 kbytes of ROM, and an 8-bit timer. The microprocessor reads the input latch, provides and expects the proper handshake sequence for receiving commands, processes the command, and updates the output latch with resulting status of the ensuing operation. The microprocessor controls the following lines and functions on the Servo Assembly:

- Enables the power driver for the capstan motor when tape motion is required.
- Provides "input" to the control loop for ramp to speed, cruise, and decelerate the capstan motor.
- Controls the control line to the sample and hold circuitry.
- Measures the output of the optical sensor interface, which is proportional to the tape speed.
- Compares this output with a reference and generates a speed error signal.
- Feeds this error signal to the DAC which causes the power bridge to drive the capstan motor at the correct speed.
- Determines when the error signal is too large (excessive load) and shuts off the capstan motor.
- Controls the control lines to the stepper drive circuitry.
- Selects the proper gap pair of the read/write head.
- Performs the diagnostics of the assembly.

#### CAPSTAN MOTOR AND LOOP CIRCUITRY

The control loop for driving the capstan motor includes the following parts:

- Capstan Motor
- Encoder Disc and Optical Sensor
- Microprocessor
- Digital to Analog Converter (DAC)
- Linear Power H-Bridge

#### Capstan Motor and Encoder

The capstan motor is a field replaceable assembly (FRA) that consists of the following items:

- Motor (bi-directional, brush type, DC motor)
- Motor bucket (mounting around the motor)
- Capstan drive (glued to the motor shaft)
- Encoder disc (200 line)
- Diode and transistor pair (infra-red sensor)

The encoder disc spins with the motor shaft. The disc interrupts the beam of the infra-red sensor which then generates current pulses. These pulses are input to the sensor interface and converted to voltage pulses. The sensor interface first amplifies the current pulses from the optical sensor. It then converts these pulses into TTL level voltage pulses which can be measured at the test point (ENC). These voltage pulses are then input to the microprocessor.

#### Microprocessor

The microprocessor measures the period of a number of encoder pulses. From this period it computes the encoder frequency. It then subtracts this frequency from a reference frequency and produces a frequency error. The error value is monitored by the microprocessor and the motor is powered-off if the error exceeds a given tolerance band.

The error signal is used as an input value for a digital filter within the microprocessor, which

forms a compensator. The output from this compensator is fed to the DAC.

In this way capstan motor speed is kept within  $\pm 0.4\%$  of the desired value.

#### Digital to Analog Converter (DAC)

The DAC is used to convert an eight bit command from the microprocessor into a unipolar, analog voltage. The output voltage of the DAC is proportional to the digital input and is used as an input to the power bridge.

#### Linear Power H-Bridge

The power bridge circuit is arranged to drive a DC brush motor in both forward and reverse directions. This is achieved by driving one or other of the upper transistors in the bridge into saturation. At the same time the corresponding lower transistor is operated in its linear region.

The bridge is controlled by the microprocessor, which selects the motor direction (REV/FWD) and when it should run (ENABLE).

### HEAD STEPPER MOTOR AND CIRCUITRY

This comprises the following elements:

- Power Switch
- Stepper Drive Circuitry
- Stepper Motor
- Microprocessor

#### Power Switch

The power switch provides power to the stepper motor. Maximum power is available when sequencing the coils. Standby power (25% power) is provided when the motor is not being stepped (to keep the head in place).

#### Stepper Drive Circuitry

This is used to select the proper motor coil and sink the coil current. Coil selection is controlled by two lines from the microprocessor. The two lines allow control of the four stepper motor coils, energizing two coils at a time.

#### Stepper Motor

The stepper motor is a four coil motor that is driven at 100 steps/second by the circuitry. Two coils are energized at a time to provide maximum stepping torque. When not stepping, 25% of the maximum stepping current is applied to the coils to hold the motor and head in place.

#### Microprocessor

The microprocessor provides the stepping sequence to the stepper motor drive and also the appropriate timing between steps. It also controls which motor coils are energized and whether the coil current should be at the stepping level or at the standby level.

The stepper motor positions the read/write head. By rotating the motor shaft clockwise or counter-clockwise the head can be moved up or down.

During the tape drive load sequence the head stepper motor is driven in a closed control loop. PREPOS and EDGE commands are sent to the microprocessor which then commands the head to move up or down until the head is over track 0. This position is then used as a reference for future open loop head positioning.

Feedback for the closed loop control comes in the form of KEYFOUND signals, generated when a read gap is over a track and a key is encountered. The PREPOS command causes the servo microprocessor to move the tape back and forth while moving the head up and down until KEYFOUND signals are detected on both channels of the read/write head.

Open loop positioning can then be used to move from track to track simply by stepping the motor a given number of steps.

## READ/WRITE CONTROL

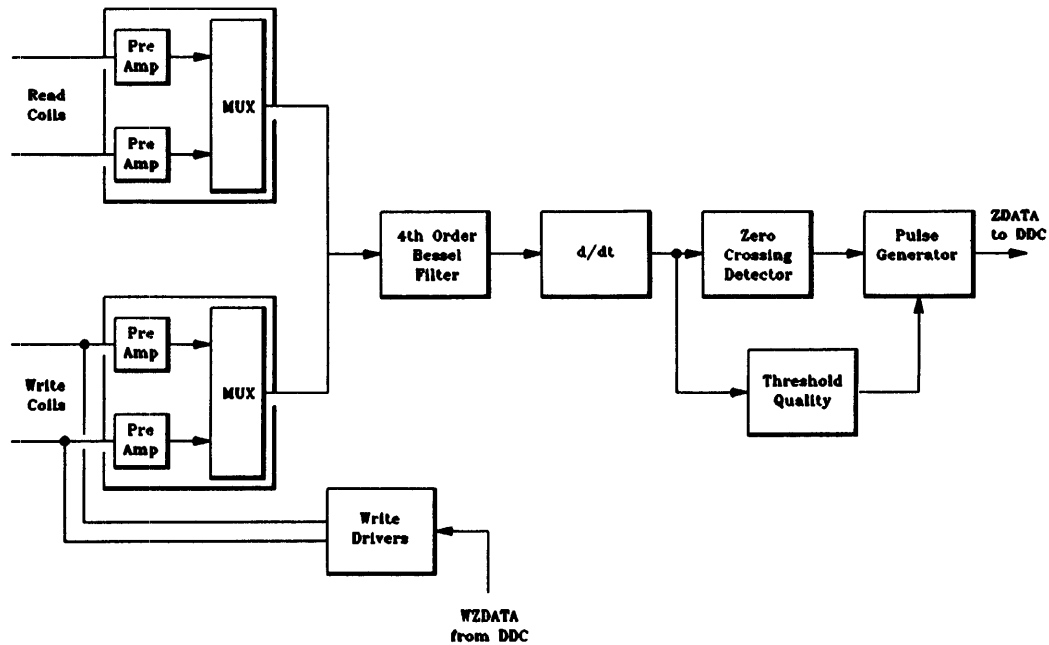

Figure 5-7. Read/Write Schematic

### WRITE CONTROL LOGIC

The write control logic is responsible for the selection of the proper set of write drivers. WRITE PROTECT and WRITE ENABLE signals are used to generate the ENABLE signal. If ENABLE is high, the write driver is able to drive the write coils. CHANNEL SELECT is used to select either the top write coil drivers or the bottom write coil drivers to be active. WZDATA toggles the drivers to actually write the data onto the tape.

### WRITE DRIVER

The write driver provides write current to the two write coils (upper and lower). There is one set of drivers for each coil and they operate by grounding each end of the write coils individually. When writing, the center tap of each write coil is connected to +12V. Thus current can pass through opposite sides of a write coil, providing flux reversals on the tape.

The Power Valid (PVAL) signal is used to disable the write driver during power-up conditions. This is to protect the tape from being written to during unstable power conditions. It operates simply by

removing the +12V from the coil center taps until the PVAL signal is asserted.

### PREAMPLIFIER

The tape head contains four coils; two read coils and two write coils. When writing, the two write coils are used; but when reading, both the read and the write coils are used. Each coil has its own preamplifier. These are SSI-117 preamplifier/multiplexer ICs set for a gain of 100 and being extremely phase-linear with a flat response. An analog switch in the input lines to each write coil preamplifier isolates the preamplifiers when the write coils are being used to write data. These analog switches are controlled by the Write Control Logic. The READ HIGH WRITE LOW (RHWL) signal is used to trigger the switches on or off.

### MULTIPLEXER SECTION

The multiplexer section is used to switch the proper head gap into the remainder of the read channel.



The multiplexers are controlled using the READ HIGH WRITE LOW and CHANNEL SELECT control lines. When one multiplexer is enabled, the other is disabled. The outputs of the multiplexers are ac-coupled and paralleled to form the input to a fourth order Bessel filter. This filter produces optimum phase linearity in the signal. The signal is then passed from the filter to a differentiator.

#### DIFFERENTIATOR

The purpose of the differentiator is to shift the phase of the signal peaks and so convert them into zero-crossings. In addition, the feedback path of the differentiator is a series resonant LCR circuit. This causes the differentiator to behave as such at data frequencies, but also to behave as a low-pass filter to higher frequencies. This means that high frequency noise is filtered out.

#### ZERO-CROSSING DETECTOR

The output of the differentiator is ac-coupled to a zero-crossing comparator, driven differentially for greatest accuracy. For each zero crossing of the input the comparator outputs change state. The outputs are used to fire two complementary monostables. The monostable outputs are ANDed together to produce ZDATA pulses which represent flux transitions on the tape.

#### THRESHOLD QUALIFY

The threshold qualify circuit is included to enhance data integrity by rejecting baseline noise. This is achieved in the following way:

Each time a tape is loaded, the tape drive firmware performs a calibration routine. One of the differentiator outputs is used to set a reference amplitude on a DAC, which relates to the peak signal amplitude of this tape/head combination. This peak value is stored for each cartridge during the load sequence. The peak value is then used as a reference. It is put into a resistive divider which produces a threshold qualification level of 24% of the peak amplitude. Two threshold comparators are then used (one for positive-going transitions and the other for negative-going transitions) to compare the data signal with this threshold qualification level. If the signal passes qualification, the comparator enables the monostable. This can then be triggered by the output of the

zero-crossing detector. If the signal does not pass qualification (a noise signal) the monostable cannot be triggered and ZDATA pulses are not produced.

### 5-5. POWER SUPPLY UNIT

The power supply is a 4 output, switching supply. It provides outputs of +5 V at 5.6 A, +12 V at 1.5 A, +12 VP (unregulated) at 4.5 A and -12 V at 0.6 A. (Output voltage tolerances are given in Table 8-1). The power-on reset signal, PVAL, is also produced by the power supply. Details of the power supply circuitry are provided in the following paragraphs.

#### INPUT CIRCUITRY

The AC line voltage is connected to the power supply PCA through an assembly mounted line cord receptacle. The front panel line switch, which is next in the circuit, controls both sides of the AC line into the power supply. The fuse is after the line switch and is in the "line side" of the AC line. The fuse value for both 115 VAC and 230 VAC is 3.0 A at 250 V. A line filter following the fuse reduces the level of line transients entering the power supply and the amount of switching noise leaving the power supply. After the filter there is a line VOLTAGE SELECTOR switch which selects nominal voltages of 115 VAC or 230 VAC. When the switch is in the 115 VAC position, a surge voltage protection device is connected across the line to protect the power supply from damage if it is inadvertently connected to 230 VAC. A blown line fuse is the only damage that can occur. A diode array and several capacitors rectify and filter the incoming AC lines. Included in this network are two thermistors that limit the initial power-on surge to approximately 25 A peak at 115 VAC or 230 VAC.

#### SWITCH-MODE SUPPLY

The rectified and filtered AC line voltage is used to power a flyback-mode DC-DC converter. This converter chops the DC input into time varying voltages, transforms them to lower levels and filters the outputs to supply the desired voltages of +5, +12 and -12 VDC. The +5 and +12 V outputs are monitored by the switching circuitry to maintain close regulation. The -12 V output is further regulated by a three terminal voltage regulator.

**CAUTION**

**POWER-ON RESET**

The power-on reset circuit is activated by the +5 V output of the power supply and produces the Power Valid signal PVAL. At power-on, PVAL remains low for at least 100 milliseconds after the +5V output reaches 4.75V or higher. Signal PVAL then goes to a high level. On power-off PVAL will go low for at least 500 microseconds prior to the +5V going below 4.75V. The power-on reset signal is connected to the Device Dependent Controller, Read/Write circuitry and Mechanism Device Controller.

No procedure for detecting bad tape sections is performed during formatting. The headers and data blocks are established for the life of the tape. Do not erase, bulk erase, degauss, or use any other methods of destroying the block sectors established by formatting.

Each header contains the timing and block information needed to allow the data blocks to be written and/or read. Each header is written twice, one the mirror image of the other, allowing it to be read from either tape direction.

**5-6. CARTRIDGE TAPE LAYOUT**

Before data can be written onto the cartridge, the cartridge must be formatted and then certified. The formatting process establishes blocks (spaces for 1024 characters) with headers throughout the tape. Certifying divides the tape width into 16 individual tracks. Each track is divided lengthways into six 256-character frames per block.

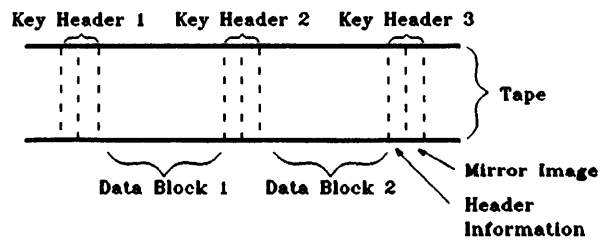

Figure 5-8. Blocks and Headers

Formatting (which prepares the tape cartridge for certifying) is done at the factory. THE HP 9144A CANNOT FORMAT A BLANK OR BULK ERASED CARTRIDGE. The Tape Drive can certify cartridges when the Initialize Media (see Table 10-3) command is sent to it. It takes approximately 40 minutes to certify a 600 foot tape and 10 minutes to certify a 150 foot tape. For this reason factory certified tapes should be used. These tapes must be initialized by the Host before they can be used.

Each data block contains the space for 1024 data characters plus 512 error correction characters.

**FORMATTING**

**CERTIFYING**

Each tape cartridge is formatted before it is sent from the factory. Formatting uses one large head that spans the entire width of the tape. Key headers and data block sections are established along the entire tape length. Manufacturing information, EOT (End Of Tape), and BOT (Beginning Of Tape) fields, which are necessary for tape access, are also written at this time.

Certifying a formatted tape cartridge divides the tape into smaller sections. The width of the tape is divided into 16 tracks and each data block length is divided into six 256-character frames.

The working area of the tape is thus divided into 16 tracks and a large number of blocks. To read and write data to the tape a tape head with two read gaps and two write gaps is used.

It is set up such that data can be read from the tape immediately after it has been written (Read-While-Write). This allows verification of the written data.

To keep from rewinding the tape after each track is read or searched the read and write gaps are repeated in reverse order. One set of gaps is positioned over the tape for writing and reading in one direction and the other pair are used in the opposite direction.

The gaps are very small and only span the width of a single track. By moving the head up and down over the width of the tape (using a head stepper motor) a pair of gaps can be positioned over any track. One pair of gaps can be positioned over eight tracks and the other pair cover the other eight.

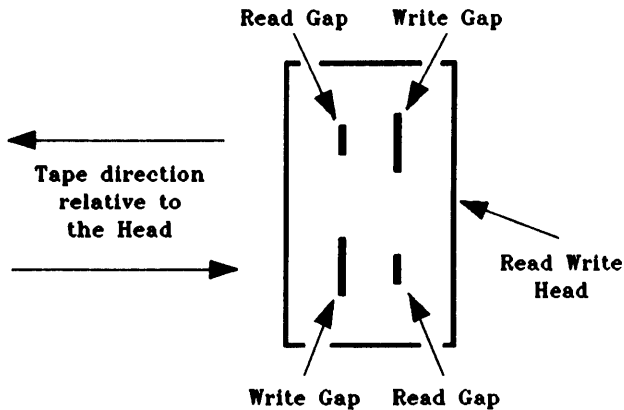

Figure 5-9. Tape head

One pair of gaps is used to write data on the tape in one direction. When the End Of Tape is reached, the tape direction is reversed and the other pair of gaps writes data on another track. In this way, data is put onto the tape in a serpentine fashion, as shown in Figure 5-10.

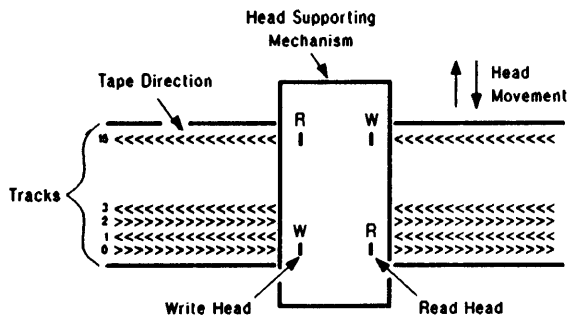

Figure 5-10. Data layout on tape

This section provides removal and replacement procedures for field replaceable assemblies (FRAs) and parts in the Tape Drive. Procedures are given in the normal order of disassembly. Each part or assembly which must be removed before access can be gained to another part or assembly is given first, followed by the next assembly which can be removed. The order of disassembly is shown in figure 6-1. The Figures in sections 6-11 and 6-14 identify the connectors on the PCAs and their mating cable assembly connectors. Figure 5-3 provides an overall cabling diagram of the Tape Drive. References are also made to figures 9-1 and 9-2, HP 9144A Exploded View, to assist in identifying and locating parts.

## 6-1. SAFETY CONSIDERATIONS

**GENERAL** - This product and related documentation must be reviewed for familiarization with safety markings and instructions before operation.

### SAFETY SYMBOLS



Instruction manual symbol: the product will be marked with this symbol when it is necessary for the user to refer to the instruction manual in order to protect the product against damage.



Indicates hazardous voltages.



Indicates earth (ground) terminal.

### WARNING

The WARNING sign denotes a hazard. It calls attention to a procedure or practice that, if not correctly performed or adhered to, could result in personal injury. Do not proceed beyond a

WARNING sign until the indicated conditions are fully understood and met.

### CAUTION

The CAUTION sign denotes a hazard. It calls attention to an operating procedure or practice that, if not correctly performed or adhered to, could result in damage to or destruction of part or all of the product. Do not proceed beyond a CAUTION sign until the indicated conditions are fully understood and met.

**SAFETY EARTH GROUND** - This is a safety class I product and is provided with a protective earthing terminal. An uninterruptible safety earth ground must be provided from the main power source to the product input wiring terminals, power cord, or supplied power cord set. Whenever it is likely that the protection has been impaired, the product must be made inoperative and be secured against any unintended operation.

**BEFORE APPLYING POWER** - Verify that the product is configured to match the available main power source according to the input power configuration instructions provided in this manual.

If this product is to be operated with an autotransformer make sure that the common terminal is connected to the earth terminal of the main power source.

### SERVICING

### WARNING

Any servicing, adjustment, maintenance, or repair of this product must be performed only by service-trained personnel.

Adjustments described in this manual may be performed with power supplied to the product while protective covers are removed. Energy available at many points may, if contacted, result in personal injury.

Capacitors inside this product may still be charged after the product has been disconnected from the main power source.

To avoid a fire hazard, fuses with the proper current rating and of the specified type (normal blow, time delay, etc.) must be used for replacement. To install or remove a fuse, first disconnect the power cord from the device. Then, using a small flat-bladed screw driver, turn the fuseholder cap counterclockwise until the cap releases. Install either end of a properly rated fuse into the cap. Next, insert the fuse and fuseholder cap into the fuseholder by pressing the cap inward and then turning it clockwise until it locks in place.

## 6-2. ELECTROSTATIC DISCHARGE CONSIDERATIONS

### **CAUTION**

The field replaceable assemblies (FRAs) in the Tape Drive contain electrostatic-sensitive devices. Take appropriate precautions when removing the FRAs from the Tape Drive. Use of an anti-static pad and wrist strap is required. (These items are contained in the anti-

static workstation, part number 9300-0749, normally found in the Customer Engineer Toolkit.)

Immediately after removal, store the FRAs in anti-static, conductive plastic bags.

## 6-3. REQUIRED TOOLS/EQUIPMENT

To repair the unit you need the Customer Engineer toolkit and the TORX kit. A ball driver (8710-1570) is also required. The HP 85 Service System is required for detailed troubleshooting.

## 6-4. REPAIR ENVIRONMENT

The Tape Drive does not need to be repaired in clean room conditions and may be disassembled in the normal operating environment. The conditions there must comply, however, with both the operational and non-operational environmental limits of the Tape Drive. These are to be found in Section 2.

Attention must also be paid to the sensitivity of the Tape Drive to electrostatic discharge and the unit should be placed upon the anti-static mat while being worked on. The wrist strap connected to this mat should also be worn.

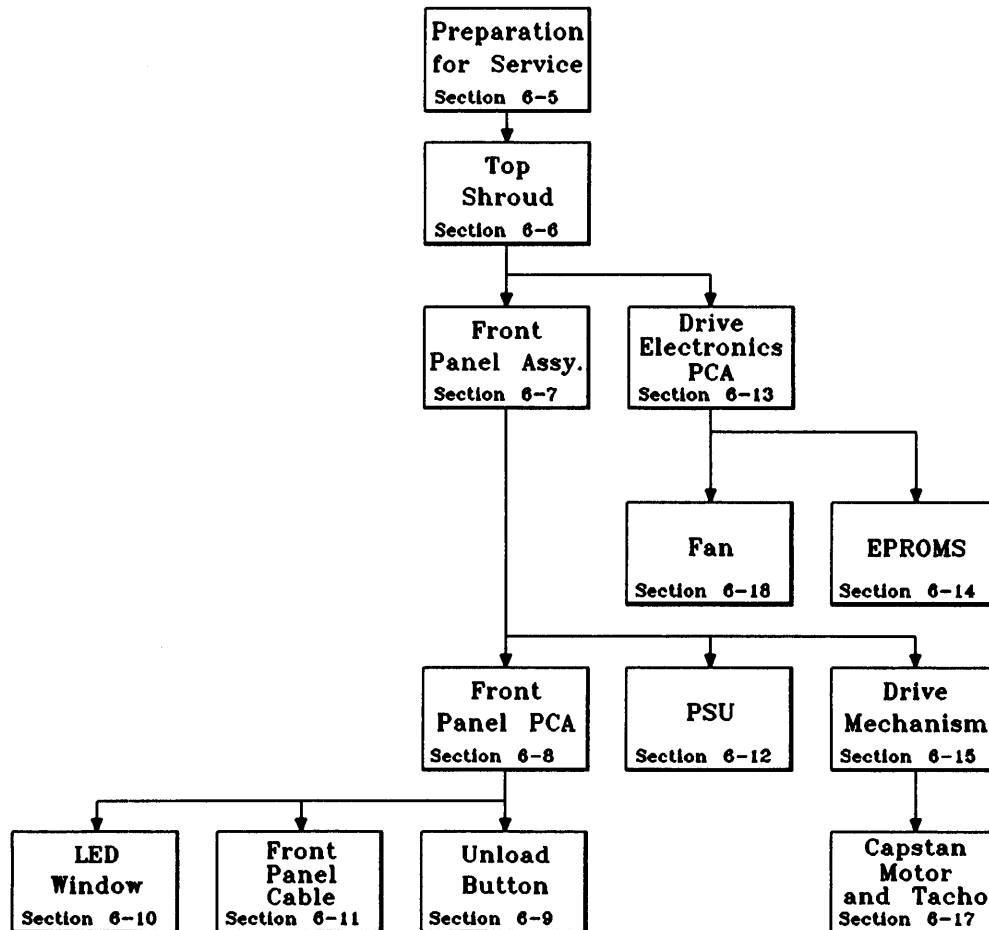

Figure 6-1. Order of Disassembly

## 6-5. DISASSEMBLY AND REASSEMBLY

### PREPARATION FOR SERVICE

Before starting any disassembly of the Tape Drive, the following steps should be taken to prepare it for service:

- 1 Set the AC LINE switch to the "off" (push-button out) position. Disconnect the power cord from the AC LINE socket on the rear of the Tape Drive.
- 2 Disconnect the HP-IB cable assembly from the connector on the rear panel.
- 3 Place the Tape Drive on the anti-static mat and connect the wrist strap to the pad. When the top shroud is removed (section 6-6),

ground the frame of the Tape Drive to the mat.

### CAUTION

Ensure that the anti-static wrist strap is attached to your wrist before removing or replacing any components in the Tape Drive.

Removal and replacement instructions for FRAs and parts in the Tape Drive are provided in the following sections. Numbers in parentheses refer to index numbers in Table 9-1 and Figure 9-1. Unless otherwise specified, replacement is the reverse of the removal procedure.

### 6-6. TOP SHROUD

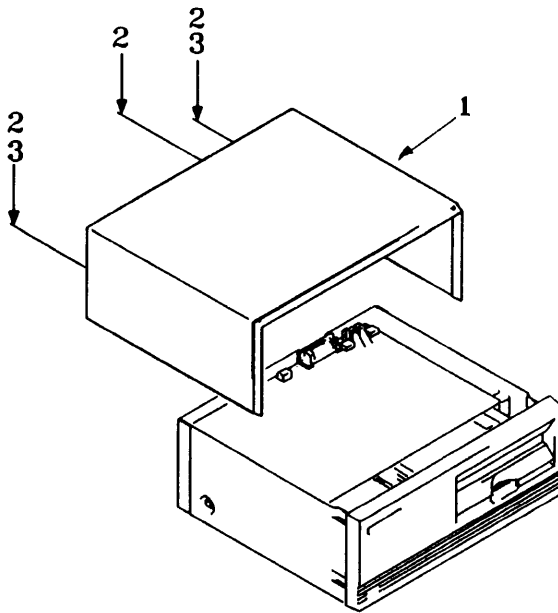

To remove the Top Shroud (1) proceed as follows:

- 1 Perform the preparation for service procedure outlined in section 6-5.
- 2 Ensure that the power cord is disconnected from the AC LINE socket on the rear panel.
- 3 Remove the three screws (2) on the rear panel, which secure the top shroud to the chassis assembly.
- 4 Carefully slide the top shroud towards the rear of the drive. When the top shroud is clear of the front panel (6), lift the shroud off the chassis.
- 5 Ground the chassis to the anti-static mat before removing any FRAs from the drive.

### 6-7. FRONT PANEL ASSEMBLY

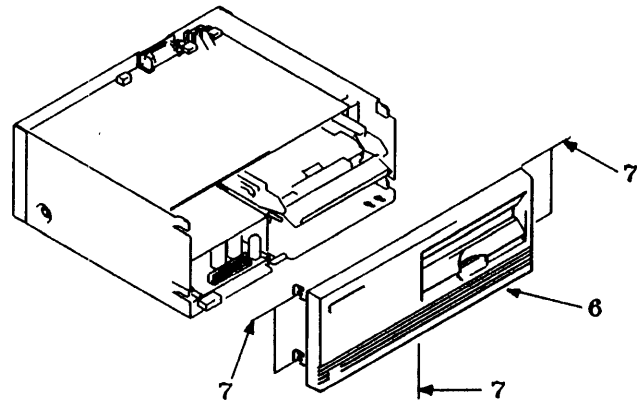

To remove the Front Panel Assembly (6) from the Tape Drive, proceed as follows:

- 1 Perform the preparation for service procedure outlined in section 6-5.
- 2 Ensure that the power cord is disconnected from the AC LINE socket on the rear panel.
- 3 Remove the Top Shroud (refer to section 6-6.)
- 4 Remove the five M3 pozidrive screws (7) with their star washers, which attach the Front Panel Assembly to the chassis.
- 5 Pull off the Front Panel Assembly far enough to allow you to unplug the cable (11) which connects the Front Panel PCA (9) to the Drive Electronics PCA (25.)

### 6-8. FRONT PANEL PCA

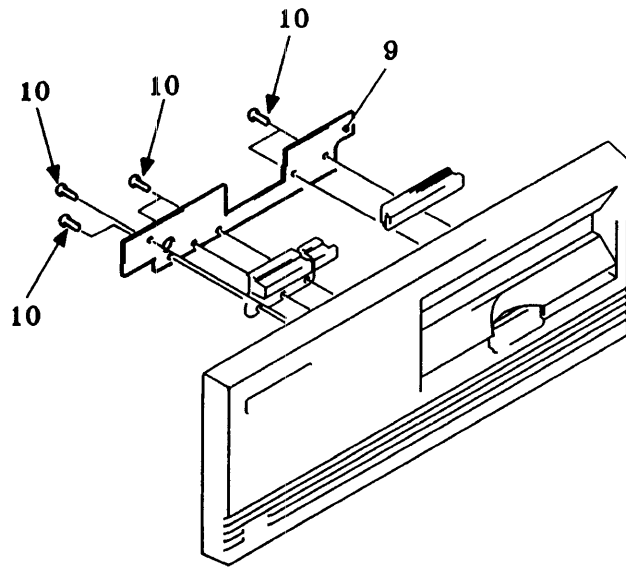

To remove the Front Panel PCA (9) from the Front Panel Assembly (6) proceed as follows.

- 1 Perform the preparation for service procedure outlined in section 6-5
- 2 Ensure that the power cord is disconnected from the AC LINE socket on the rear panel.
- 3 Remove the top shroud (refer to section 6-6).
- 4 Remove the Front Panel Assembly (refer to section 6-7).
- 5 Place the Front Panel Assembly face down on the anti-static mat.
- 6 Remove the six self-tapping screws (10) which attach the Front Panel PCA (9) to the Front Panel.
- 7 Lift off the Front Panel PCA.

### 6-9. UNLOAD BUTTON

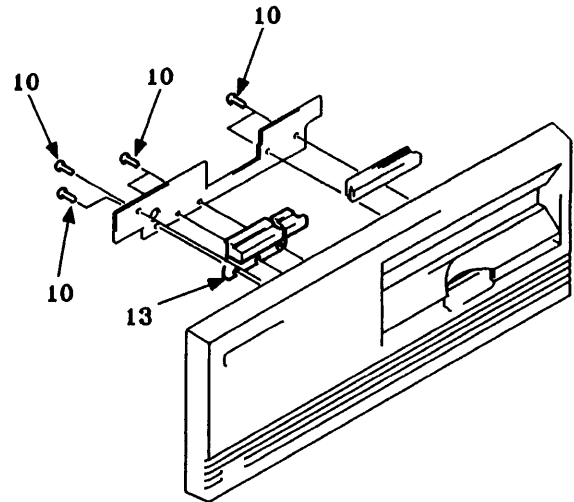

To remove the Unload Button (13) from the Front Panel Assembly (6) proceed as follows.

- 1 Perform the preparation for service procedure outlined in section 6-5
- 2 Ensure that the power cord is disconnected from the AC LINE socket on the rear panel.
- 3 Remove the top shroud (refer to section 6-6).
- 4 Remove the Front Panel Assembly (refer to section 6-7).
- 5 Remove the Front Panel PCA (refer to section 6-8).
- 6 Lift out the Unload Button (13).



### 6-10. LED WINDOW

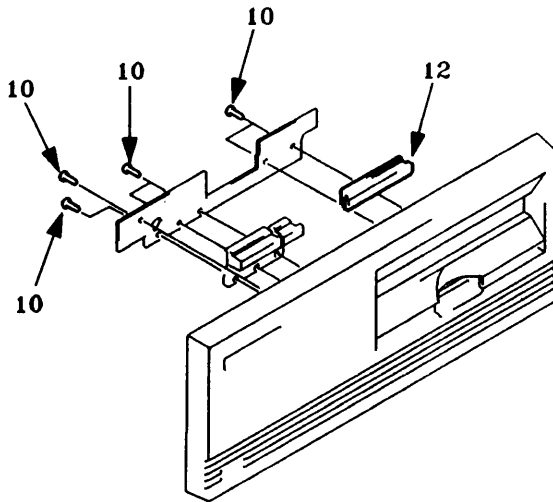

To remove the LED Window (12) from the Front Panel Assembly (6) proceed as follows.

- 1 Perform the preparation for service procedure outlined in section 6-5
- 2 Ensure that the power cord is disconnected from the AC LINE socket on the rear panel.
- 3 Remove the top shroud (refer to section 6-6).
- 4 Remove the Front Panel Assembly (refer to section 6-7).
- 5 Remove the Front Panel PCA (refer to section 6-8).
- 6 Lift out the LED Window (12).

### 6-11. FRONT PANEL CABLE

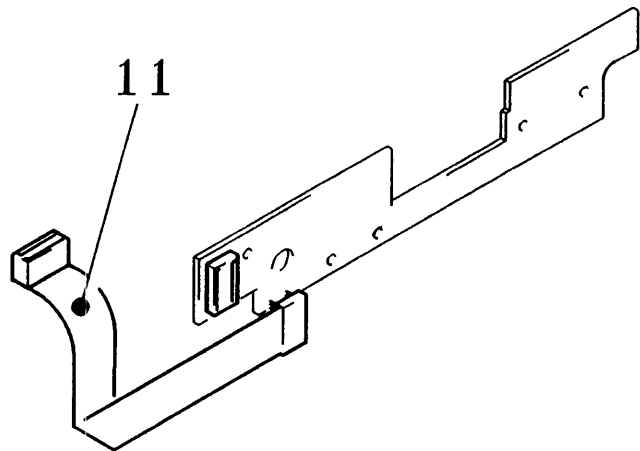

To remove the Front Panel Cable (11) from the Front Panel Assembly (6) proceed as follows.

- 1 Perform the preparation for service procedure outlined in section 6-5
- 2 Ensure that the power cord is disconnected from the AC LINE socket on the rear panel.
- 3 Remove the top shroud (refer to section 6-6).
- 4 Remove the Front Panel Assembly (refer to section 6-7).
- 5 Remove the Front Panel PCA (refer to section 6-8).
- 6 Disconnect the Front Panel Cable (11) from the Front Panel PCA.

## 6-12. POWER SUPPLY UNIT

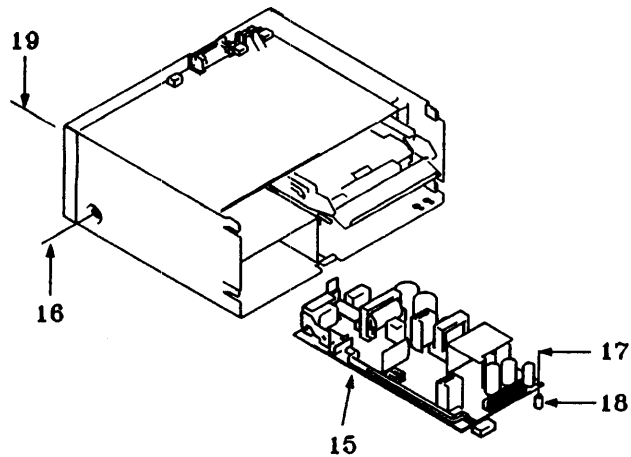

To remove the Power Supply Unit (15) from the Tape Drive, proceed as follows:

- 1 Perform the preparation for service procedure outlined in section 6-5.
- 2 Ensure that the power cord is disconnected from the AC LINE socket on the rear panel.
- 3 Remove the top shroud (refer to section 6-6).
- 4 Remove the Front Panel Assembly (refer to section 6-7).
- 5 Remove the screw (16) attaching the Earth bonding strap to the chassis.
- 6 Remove the screw (19) attaching the Power Supply Unit (15) to the rear of the chassis.
- 7 Unplug the cables which connect the power supply unit to the drive electronics PCA (25) and the fan (21).
- 8 Remove the screw (17) and spacer (18) attaching the front of the power supply to the base of the chassis.
- 9 The power supply assembly can now be removed from the front of the unit.

## 6-13. DRIVE ELECTRONICS PCA

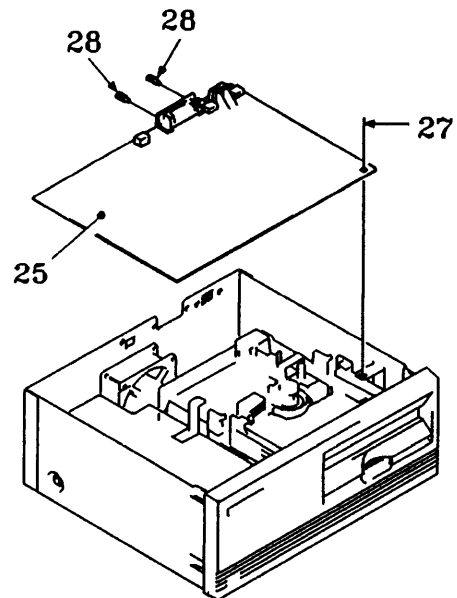

To remove the Drive Electronics PCA (25) from the Tape Drive, proceed as follows:

- 1 Perform the preparation for service procedure outlined in section 6-5.
- 2 Ensure that the power cord is disconnected from the AC LINE socket on the rear panel.
- 3 Remove the Top Shroud (refer to section 6-6).
- 4 Unplug the power cable connector (14) from the socket on the Drive Electronics PCA (25).
- 5 Remove the retaining screw (27) which attaches the front of the Drive Electronics PCA to the chassis.
- 6 Unscrew and remove the two 9/32 AF screwed spacers (28) which attach the HP-IB connector to the rear panel.
- 7 Lift the Drive Electronics PCA slightly to gain access to the component side of the board. Unplug the cables connecting it to the front panel PCA and the drive mechanism.
- 8 The Drive Electronics PCA can now be lifted clear of the chassis and stored in an anti-static bag.

## 6-14. EPROMs

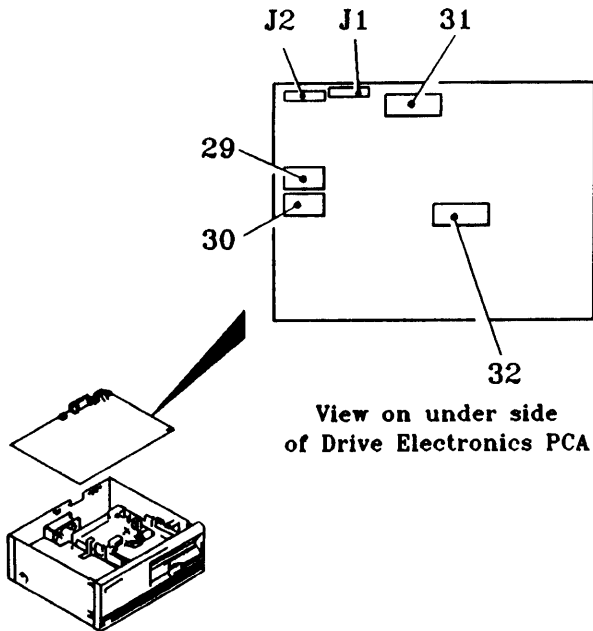

To remove the EPROMs from the Drive Electronics PCA (DE PCA), proceed as follows:

- 1 Perform the preparation for service procedure outlined in section 6-5.
- 2 Ensure that the power cord is disconnected from the AC LINE socket on the rear panel.
- 3 Remove the top shroud (refer to section 6-6).
- 4 Remove the DE PCA (see section 6-13).
- 5 Remove the EXEC EPROM (29) from the 28-pin socket U132 on the DE PCA (25).
- 6 Remove the Unit Code EPROM (30) from socket U128 on the DE PCA.
- 7 Remove the Servo Processor/ROM (32) from socket U305 on the DE PCA.
- 8 Remove the DDC Processor ROM (31) from the socket U33 on the DE PCA.
- 9 Place all the EPROMs on a piece of anti-static foam.

Replacement is the opposite of the removal procedure. Take care to ensure that the EPROMs

are replaced in the correct sockets and are the correct way round, with their indents facing the same way as the other components. Check that all IC legs are installed in the socket.

## 6-15. DRIVE MECHANISM

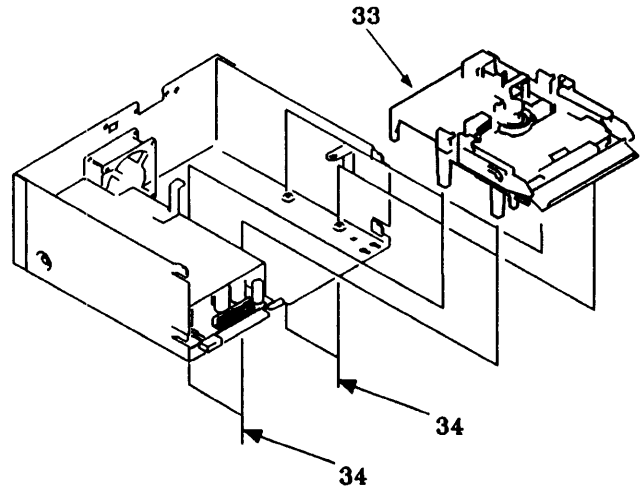

To remove the drive mechanism assembly (33) from the Tape Drive, proceed as follows:

- 1 Perform the preparation for service procedure outlined in section 6-5.
- 2 Ensure that the power cord is disconnected from the AC LINE socket on the rear panel.
- 3 Remove the Top Shroud (refer to section 6-6).
- 4 Remove the Front Panel Assembly (section 6-7)
- 5 Remove the DE PCA (see section 6-13).
- 6 Turn the unit over and rest it on one side.
- 7 Make sure that the unit remains on the anti-static mat, as this also helps to prevent damaging the surface of the table on which you are working.
- 8 Supporting the drive mechanism with one hand, remove the four screws (34) attaching it to the base.

- 9 Put the unit back on its base and lift out the drive mechanism (33).

### 6-16. FAN

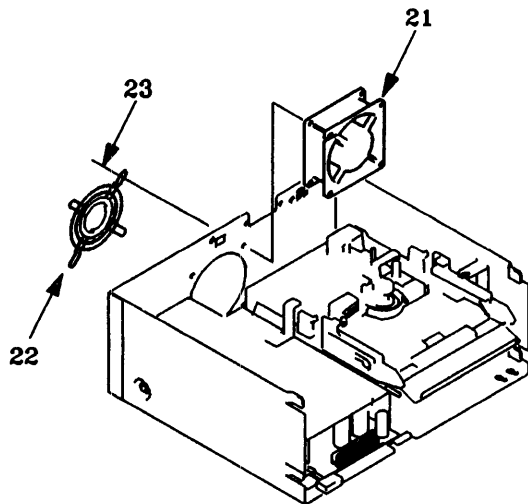

To remove the fan (21) from the unit, proceed as follows:

- 1 Perform the preparation for service procedure outlined in section 6-5.
- 2 Ensure that the power cord is disconnected from the AC LINE socket on the rear panel.
- 3 Remove the Top Shroud (refer to section 6-6).
- 4 Remove the DE PCA (see section 6-13).
- 5 Remove the Front Panel (see section 6-7).
- 6 Unclip the fan power cable from its clip on the side of the power supply housing.
- 7 Unplug the fan cable from socket J2 on the power supply PCA.
- 8 Remove the four self-tapping screws (23) attaching the fan to the rear panel.
- 9 Lift out the fan from the unit.

### 6-17. CAPSTAN MOTOR AND TACHOMETER

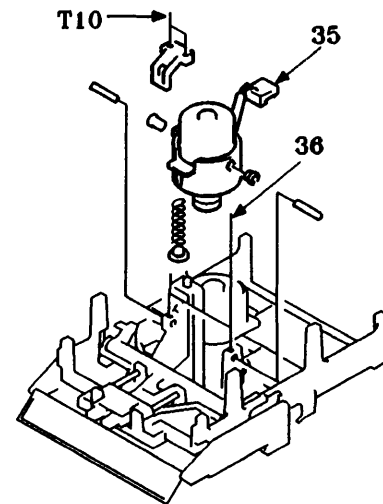

To remove the capstan motor and tachometer (35) from the unit, proceed as follows:

- 1 Perform the preparation for service procedure outlined in section 6-5.
- 2 Ensure that the power cord is disconnected from the AC LINE socket on the rear panel.
- 3 Remove the Top Shroud (refer to section 6-6).
- 4 Remove the front panel (see section 6-7).
- 5 Remove the DE PCA (see section 6-13).
- 6 Remove the drive mechanism (section 6-15).
- 7 Turn the drive mechanism upside-down and slacken the two set screws (36) securing the motor bucket swivel rods.
- 8 Remove the two T10 screws attaching the motor bucket to the eject mechanism.
- 9 Pull out the two motor bucket swivel rods enough to let you lift out the capstan motor assembly. Keep the spring which is now free from the eject mechanism, and also the three insulating bushes (black plastic). These bushes insulate the motor housing from the drive mechanism chassis and the assembly should not be put back together without them.

There are no adjustable parts in the HP 9144A Tape Drive.

This section provides service information to help you mend a faulty Tape Drive. Fault finding is quickly achieved by using the comprehensive self-test and diagnostic facilities built into the unit.

## 8-1. TROUBLESHOOTING STRATEGY

The HP 9144A is repaired to the Field Replaceable Assembly (FRA) level. A combination of exchange and non-exchange parts from the CSD exchange program are used to achieve this. The field replaceable assemblies are:

- 09144-66519 Drive Electronics PCA
- 09144-66501 Drive Mechanism
- 09144-65209 Capstan Motor/Tacho
- 09133-67120 Power Supply Unit

To aid troubleshooting, the Tape Drive has self-test capabilities and diagnostic routines which may be initiated at power-on, by the operator or through the host. These self-tests are described in detail in section 3-11. They provide an indication of the failed FRA(s), which can then be removed and replaced.

## 8-2. MINIMUM CONFIGURATION

The minimum configuration for host-initiated diagnostics comprises the Tape Drive linked to its HP 3000 or HP 9000 host for online or offline diagnostics. Alternatively, the existing host may be replaced by an HP 85 and diagnostics can then be performed using the CS/80 External Exerciser tape. If neither of these hosts are available for performing diagnostics then the Tape Drive's own internal diagnostics may be used (see section 3-11.).

## 8-3. TROUBLESHOOTING PROCEDURES

When troubleshooting the Tape Drive, the first thing to consider is whether the fault is repeatable or intermittent. This can be determined to some extent by repeating the self-test procedures several times. A repeatable fault usually causes the same self-test result to be presented each time the self-test is performed. By contrast, an intermittent fault occurring at random intervals may not always cause a self-test failure.

In the case of a repeatable fault, the self-test will identify the the failing FRA with a 95% certainty. In the event that more than one FRA is listed as the possible cause of the failure, replace the FRAs, one at a time, in the order given in the self-test display.

### NOTE

Cable faults (such as an open-circuit conductor or a loose connector) may present a multiple FRA failure message. The FRAs listed will be the FRAs at either end of the defective cable.

All cabling should therefore be checked before replacing any FRAs.

Testing circuitry with a meter or oscilloscope should be restricted to checking the operation of the power supply. All other circuits are adequately tested by the system diagnostics and self-tests.

Test points are available on the PSU PCA next to the output connector J2. (see Figure 5-3, sheet 1). These should be checked with a digital voltmeter to confirm the correct voltages compared with Table 8-1. They should then be checked with an oscilloscope to determine the peak-to-peak ripple voltage.

Table 8-1. Power Supply Voltages

Test Point	Specification	Ripple (P-P)
+5V	+5 ± 150mV	50mV
+12V	+12 ± 360mV	100mV
-12V	-12 ± 600mV	100mV
+12VP	+12 ± 1V	100mV
PVAL	3.5V min	-

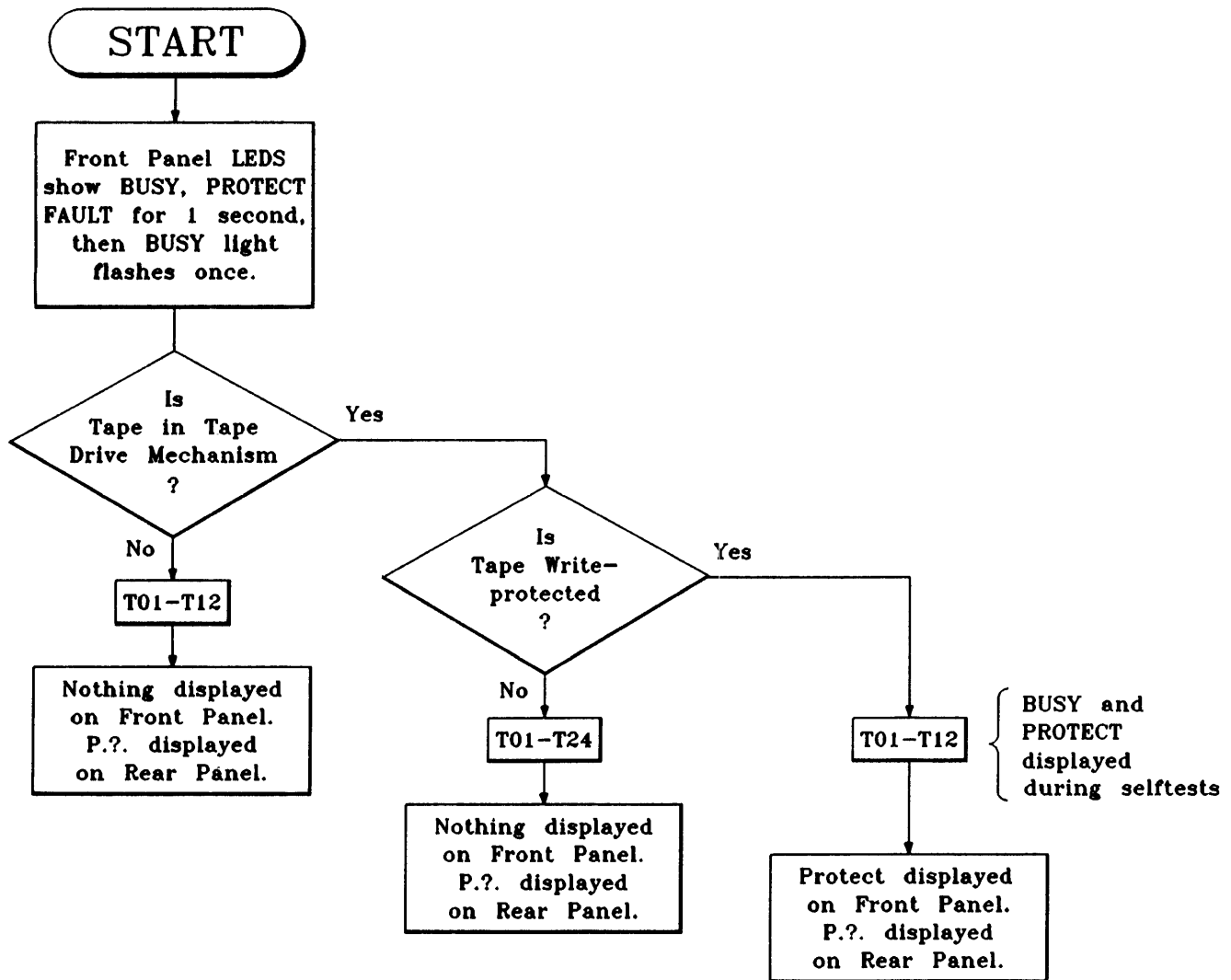

Figure 8-1. Self-Test Sequence Flowchart  
(See Table 8-2. for a description of individual tests.  
T01 - T24 are tests 1-24 in Table 8-2, TERRORS).

**NOTE**

### 8-4. ERROR CODES

As a result of self-tests the following codes may be displayed by the self-test displays on the rear panel.

The Units which may be faulty are given by the following displays:

Unit 0, the Drive Mechanism

Unit 2, the Internal Controller

For Unit 0, the Drive Mechanism, the Field Replaceable Assemblies that may be shown as faulty are:

Not Discernible - An assembly failed and the test showed that it was good

Drive Mechanism (including Capstan Motor and Head Stepper Motor)

Device Dependent Controller (DDC)

Read/Write Circuitry (R/W)

Probably a dirty tape head

Host Dependent Controller (HDC)

Servo Circuitry (S)

Head Stepper Motor (Not Replaceable)

Capstan Motor and Optical Sensor

Since the HDC, DDC, R/W and S circuitry are all contained in the Drive Electronics PCA (DE PCA), any of the codes A2, A3, A5, A7 indicate that the DE PCA is faulty.

There is no error code

The Power Supply is faulty if either of the full stops (i.e., ) are not illuminated.

If there is a Unit 2 failure, in the Internal Controller (on the HDC), the error code sequence shown on the rear panel differs from Unit 0 failure sequence (see section 3-11). The sequence is:

Fail with address "?"

Unit 2 fails. The display does not cycle through Unit 0 because the self-test routine checks the controller first. Having found a fault there, it then stops.

Host Dependent Controller circuitry. This is the only FRA that can fail when there is only a Unit 2 failure.

If the front panel display is illuminated, but the test results give a Pass Condition, it is most probable that the tape cartridge is faulty. Loading another cartridge and repeating the test would help to establish whether it was a faulty cartridge.

Next in the self-test sequence the individual failing tests may be indicated. The following tables give the test numbers with a brief description of each test and the MSFRAs.

Table 8-2 shows the test errors which may be displayed as a result of initiating a self-test. Table 8-3 shows the errors which may be displayed at any time while the Tape Drive is in use, as the result of a fault.



Table 8-2. Diagnostic/Self-Test Errors (1 ERRORS)

NUMBER		CAUSE or Test Description	SUSPECT HARDWARE
DEC	HEX		
00		Complete test of Tape Drive	
01		HDC-DDC interface. Read Servo Status	DE PCA
02		DDC Circuitry	
03		a) Microcomputer test	DE PCA
04		b) Read/Write loopback	DE PCA
05		HDC-DDC Read/Write loopback.	DE PCA
06		HDC-DDC-Servo Interface	DE PCA
07		Servo Circuitry	
08		a) Microcomputer	DE PCA
09		b) Capstan Motor Drive Circuit	DE PCA, Capstan Motor
10		c) Tachometer	DE PCA, Capstan Motor
11		d) Capstan Motor	Capstan Motor, DE PCA
12		e) Head Stepper Circuit	DE PCA and Head Stepper
13		Test the read portion of the R/W Circuitry.  Start by executing a Put Gaps on Tape command. This will assume unit works and a Key Found signal can be generated. A failure of this command will cause the test to continue through the read tests, trying to diagnose what caused the failure. If the read tests all pass, the testing will halt and the test number shown will be the failing test.	DE PCA

Table 8-2. Diagnostic/Self-Test Errors (TERRORS) continued

NUMBER		CAUSE or Test Description	SUSPECT HARDWARE
DEC	HEX		
14		With Read Gain set to minimum and Channel 0 positioned on the tape, enable Read with Read Head 0 and check for Overthreshold not being set.	DE PCA
15		With Read Gain set to minimum and Channel 0 positioned on the tape, enable Read with Write Head 0 and check for Overthreshold not being set.	DE PCA
16		With Read Gain set to a maximum and Channel 0 positioned on the tape, enable Read with Read Head 0 and check for overthreshold being set.	DE PCA
17		With Read Gain set to maximum and Channel 0 positioned on the tape, enable Read with Write Head 0 and check for Overthreshold being set.	DE PCA
18		With Read Gain set to a minimum and Channel 1 positioned on the tape, enable Read with Read Head 1 and check for Overthreshold not being set.	DE PCA
19		With Read Gain set to a minimum and Channel 1 positioned on the tape, enable Read with Write Head 1 and check for Overthreshold not being set.	DE PCA
20		With Read Gain set to a maximum and Channel 1 positioned on the tape, enable Read with Read Head 1 and check for Overthreshold being set.	DE PCA
21		With Read Gain set to maximum and Channel 1 positioned on the tape, enable Read with Write Head 1 and check for Overthreshold being set.	DE PCA
22		Test the Write portion of the R/W Circuitry.	DE PCA
23		After the edge of tape has been found and the tape wound to BOT, execute a Locate and Write to track 0, Key 4 with Channel 0. Read back the written data and verify it is the same data that was written. If not, return an error.	DE PCA, Drive Mechanism
24		Execute a Locate and Write to track 7, Key 5 with Channel 1. Read back the written data and verify it is the same data that was written. If not, return an error.	DE PCA, Drive Mechanism

Table 8-3. Run-Time Drive Errors (DERRORS).

NUMBER		CAUSE or Test Description	SUSPECT HARDWARE
DEC	HEX		
177	B1	<p>Recoverable dual errors (one byte)</p> <p>Two frames were bad (CRC error or missing) which were recoverable through XOR circuitry. (Marginal or recoverable)</p>	None
178	B2	<p>Single frame error (one byte)</p> <p>Only one frame with bad CRC or missing. (Marginal or recoverable)</p>	None
179	B3	<p>Unrecoverable data (one byte)</p> <p>Combination of frame CRC errors or missing frames such that data could not be recovered through XOR circuitry. (Marginal, recoverable or unrecoverable)</p>	None
180	B4	<p>DMA handshake error (one byte)</p> <p>Overflow or underflow has occurred between HDC and DDC. (Marginal, recoverable or unrecoverable)</p>	DE PCA
181	B5	<p>DMA failure (one byte)</p> <p>Not enough frames detected during read or read-while-write. (Marginal recoverable, or unrecoverable)</p>	DE PCA
185	B9	<p>Key error (one byte)</p> <p>One key past target, keys past target, bad key CRC, time-out of key sync, wrong key sent or verify failed. This error occurs during transfer, not seek to target or seek to perform retries. (Marginal, recoverable, unrecoverable, or latency induced)</p>	DE PCA
186	BA	<p>Seek error (one byte)</p> <p>Seek to target required retries or failed because of time-out or keys past target. (Unit fault)</p>	DE PCA

Table 8-3. Run-Time Drive Errors (DERRORS) continued.

NUMBER		CAUSE or Test Description	SUSPECT HARDWARE
DEC	HEX		
187	BB	Seek to a jump spare (one byte)  A latency was induced due to seeking to a jump spare during transaction (Latency induced)	DE PCA
190	BE	Reposition failure (one byte)  Reposition of tape to next target address after tape access command required retries or failed. (Unit fault)	DE PCA
193	C1	Log overflow (two bytes)  Log indicated in postbyte overflowed. (Possible loss of entries)  0 = Manufacturer's block 1 = Sparing table 2 = Error rate test log 3 = Runtime error log 4 = Use log (Maintenance track overflow)	Tape Drive Subsystem: DE PCA Drive Mechanism
194	C2	Unable to read log (two bytes)  Log indicated in postbyte could not be read in multiple retries. (For sparing table, this could mean that it was never written or errors preclude it from being written. For other logs, if log was never written this error will not occur. Log will be returned as empty.) Postbyte log codes are defined above. (Unrecoverable data, uninitialized media, unit fault)	Uninitialized cartridge, Tape Drive Subsystem: DE PCA Drive Mechanism
195	C3	Unable to write log (two bytes)  Log indicated in postbyte could not be written on any track in multiple retries. Postbyte log codes are defined above. (Unrecoverable data)	
196	C4	Log only written on one track (two bytes)  Log indicated in postbyte could only be written on one track rather than the usual two. Postbyte log codes are defined above. (Unrecoverable data)	

Table 8-3. Run-Time Drive Errors (DERRORS) continued.

NUMBER		CAUSE or Test Description	SUSPECT HARDWARE
DEC	HEX		
200	C8	<p>Servo error (two bytes)</p> <p>Command to servo processor was not successfully executed. Postbyte contains status returned by servo processor:</p> <p>00H = Power on state (servo processor is reset)            FFH = Busy/Active            1(T)H = Rewind/T = track            2(T)H = Forward/T = track            3(T)H = Stopped/T = track            40H = Invalid command            41H = Loss of speed control            44H = Cannot find edge of tape            48H = Pre-pos gaps, no keys            50H = Cannot calibrate speed            61H = Unspool likely, no keys found            64H = EOT active            68H = BOT active            (Unit fault)</p>	
206	CE	<p>Load error (two bytes)</p> <p>This cartridge failed the load sequence. Failure is recorded in postbyte:</p> <p>1 = Load diagnostics failed            2 = Seek to EOT failed            3 = Speed calibration failed            4 = Gain set failed            5 = Seek to BOT failed            6 = Edge find failed            (Unit fault)</p>	
207	CF	<p>Unload error (two bytes)</p> <p>This cartridge did not successfully complete the normal unload sequence (logs may not have been updated). Failure is recorded in postbyte:</p> <p>1 = Diagnostic result indicated a hardware failure so normal unload was not attempted.</p> <p>2 = Seek to EOT failed            (Unit fault)</p>	

Table 8-3. Run-Time Drive Errors (DERRORS) continued.

NUMBER		CAUSE or Test Description	SUSPECT HARDWARE
DEC	HEX		
209	D1	<p>Not certified</p> <p>This cartridge is not certified. (Uninitialized media)</p>	None
210	D2	<p>Certify command failed</p> <p>Attempt to certify a cartridge failed. Possible reasons are:</p> <p>1 Requires &gt;80% of the spares to be used up. 2 Can't write spares table to tape. 3 Error rate test failed due to log overflow or seek failure. 4 Transfer canceled 5 Certify specified with 0 loops.</p> <p>(Uninitialized media)</p>	
216	D8	<p>Hardware fail (one byte)</p> <p>Attempt to access the tape (with a non-diagnostic command) when previous diagnostic command, power-on or load diagnostics indicated a hardware failure. (Unit fault)</p>	
217	D9	<p>Write circuit failure (one byte)</p> <p>Attempt to perform a write command when write circuitry has failed power-on or load diagnostics or has failed a diagnostic command. (Unit fault)</p>	
223	DF	<p>No buffers in system (one byte)</p> <p>No buffers are available to complete transaction. (Controller fault)</p>	

## **8-5. INITIATING DIAGNOSTICS FROM A HOST COMPUTER**

The test philosophy is that the Host executes a Transparent Loopback test (Read and Write) to verify functionality of the HP-IB interface and a large portion of the HDC board. If this test is unsuccessful, the host computer knows that the Most Suspected Field Replaceable Assembly (MSFRA) is the HDC circuitry.

Having completed the Loopback test, the host computer instructs the HDC to Initiate Diagnostics. The parameters passed with the command tells the HDC whether to start the diagnostic at the top of the hierarchical chart, or at some lower level, and the number of times to repeat the test.

The HDC controls all levels of Diagnostic Testing. This means that the diagnostic code residing on the HDC is sent memos to execute diagnostic commands. The diagnostic code then instructs the DDC to execute its diagnostics. The diagnostic code then instructs the Servo circuitry to execute its diagnostics. Then, by using both the DDC and the Servo, the diagnostic code executes a test of the Read/Write circuitry. This must be done since there is no self-test hardware on the R/W circuitry.

If the command is to test from the beginning, the diagnostic code issues commands in a sequential order until either the test is completed or a failure is discovered. The diagnostic code then terminates the testing and updates the MSFRA and the failing test number which are located in the Request Status summary and the back panel displays.

If the command is to execute a specific test, the diagnostic code sends the appropriate processor (e.g., DDC or RWS assembly) the command to execute the specific test. The HDC does not fail to send the message because it thinks that there is a failure higher up than the unit to be tested. For example, the diagnostic code sends a command to the DDC which tests the Read/Write circuitry even if the DDC appears to be bad.

### **TEST DESCRIPTIONS**

#### **HDC/DDC INTERFACE**

The HDC/DDC Interface test consists of a loopback test. The diagnostic code sends the DDC a Loopback Command with an accompanying 4-bits (nibble). The DDC reads this nibble, inverts it (ones complement), duplicates it into an upper nibble, and sends it back to the diagnostic code. This is done for 8 bytes. The diagnostic code decides if the correct data (the entire byte) is received and if not, declares that the DDC is faulty, with the HDC as the alternate MSFRA.

#### **DEVICE-DEPENDENT CONTROLLER**

The testing for the DDC is the self-test that is executed after every power-on. This tests >95% of the circuitry on the DDC and the results are completely independent from other circuitry, with the exception of the HDC and power supply.

This test includes testing out the microcomputer and the write and read circuitry, via internal loopback. The test stops short of sending signals to or receiving signals from the Read/Write circuitry. If self-test fails, the DDC sends a Failing Response to the diagnostic code which causes the MSFRA to be the DDC.

If the DDC passes the self-test, it sends a Passing Response to the diagnostic code.

#### **HDC/DDC/SERVO INTERFACE**

The HDC/DDC/Servo Interface test consists of a loopback test. The diagnostic code sends the Servo a Loopback Command with an accompanying byte. The Servo reads this byte, inverts it (ones complement), and sends it back to the diagnostic code. This is done for 14 bytes. The diagnostic code decides if the correct data is received and if not, declares that the Servo is faulty, with the DDC and HDC as the alternate MSFRAs.

#### **SERVO CIRCUITRY**

The testing of the Servo circuitry tests >95% of the circuitry. The microcomputer and associated digital circuitry is tested.

The capstan motor electronics and optical sensor electronics are tested for functionality. The motor and optical sensor are then tested for functionality.

The testing for the head stepper is to determine if voltage is being sent to the motor. If there is voltage, the Servo assumes the motor works.

**NOTE**

Other testing (i.e., determining if a signal from the head disappears when the gap moves off the tape) is needed to verify that the head does indeed move because the head is run open loop.

**READ/WRITE CIRCUITRY**

The testing of the Read/Write circuitry depends on the Servo circuitry being functional. The test first tests out the read channel. It accomplishes this using the adjustable gain of the read amplifier and the Overthreshold circuitry. This checks out

the functionality of the heads, pre-amps, multiplexer, and part of the secondary amplifier. A failure on one of these, but not all, is probably indicative of a damaged or dirty Head. Otherwise the failure is on the Read/Write circuitry.

If the read channel is operational, the write channel is checked. This is done by creating one block of random data, writing the data to a scratch block of the tape, reading it back, and verifying that the read data was identical to the written data. In the event of a failure this is done repetitively on different tracks to ensure that the tape is not at fault. This is done using both head channels.

**AVAILABLE TESTS**

The discrete unit tests are accessible to the Host via CS/80 Commands. These tests are defined as shown in Table 8-2.



This section provides listings of all field-replaceable parts and an illustrated parts breakdown for the Tape Drive, as well as replaceable parts ordering information.

## 9-1. REPLACEABLE PARTS INFORMATION

Replaceable parts for the Tape Drive are listed in disassembly order in table 9-2 and illustrated in figure 9-1. In the table, attaching parts are listed immediately after the item they attach. Items in the DESCRIPTION column are indented to indicate relationship to the next higher assembly. In addition, the symbol "---X---" follows the last attaching part for that item. Indentation of the items in the tables is as follows:

- Major Assembly
- \*Replaceable Assembly
- \*Attaching Parts for Replaceable Assembly
- \*\*Subassembly or Component Part
- \*\*Attaching parts for Subassembly or Component Part

The replaceable parts listings provide the following information for each part:

- FIG. & INDEX NO. The figure and index number which indicates where the replaceable part is illustrated.
- HP PART NO. The Hewlett-Packard part number for each replaceable part.
- DESCRIPTION. A description of each replaceable part. Refer to table 9-5 for an explanation of abbreviations used in the description column.
- MFR CODE. The 5-digit code that denotes a typical manufacturer of a part. Refer to table 9-1 for a list of manufacturers who correspond to the codes.
- MFR PART NO. The manufacturer's part number of each replaceable part.

- UNITS PER ASSY. The total quantity of each part used in the major assembly.

The MFR CODE and MFR PART NO. for common hardware items are listed as 00000 and OBD (order by description) respectively, because these items can usually be purchased locally.

## 9-2. ORDERING INFORMATION

To order replaceable parts for the Tape Drive, address the order to your local Hewlett-Packard Sales and Support Office. Sales and Support Offices are listed at the back of this manual. Specify the following information for each part ordered:

- Model and full serial number.
- Hewlett-Packard part number.
- Complete description for each part as provided in the replaceable parts listings. Refer to the appropriate part of section 11 if you can't find the part listed in Table 9-1.

## 9-3. ILLUSTRATED PARTS BREAKOUT

See Figure 9-1 for an exploded view of the HP 9144A Tape Drive.

## 9-4. EXCHANGE ASSEMBLIES

The following assemblies are included in the current exchange program:

- 09144-69501 DRIVE MECHANISM
- 09144-69519 DRIVE ELECTRONICS PCA

**9-5. FIELD REPLACEABLE PARTS LIST**

A list of Field Replaceable Parts is given in Table 9-2.

**9-6. CODED LIST OF MANUFACTURERS**

A list of manufacturers is given in table 9-1.

**Table 9-1. Coded List of Manufacturers**

Code No.	Manufacturer	Address
28480	Hewlett-Packard Co. ....	Palo Alto, CA

These code numbers are taken from the Federal Supply Code for Manufacturers Cataloging Handbooks H4-1, and H4-2, and their supplements.

**9-7. ABBREVIATIONS LIST**

A list of abbreviations is given in Table 9-3.

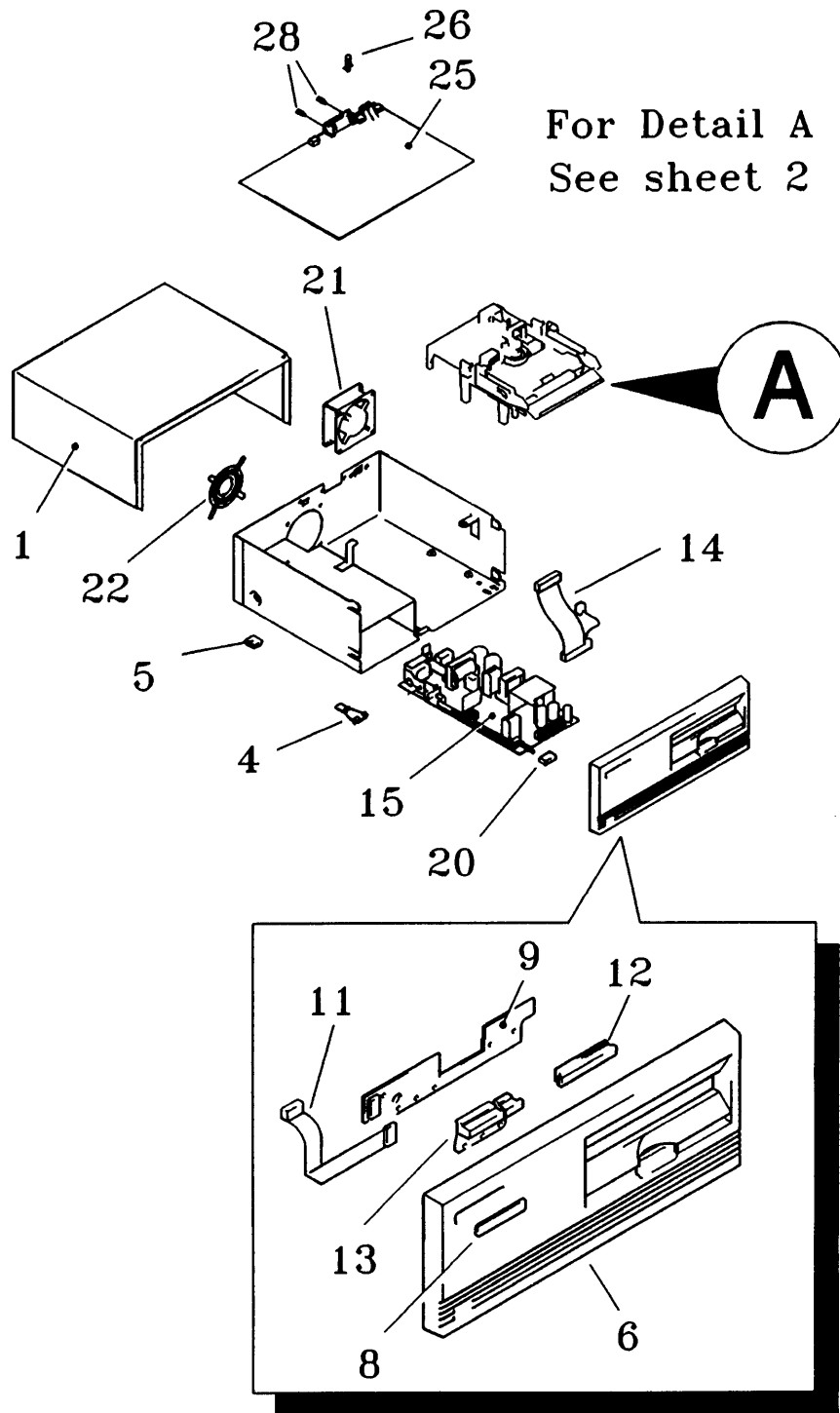
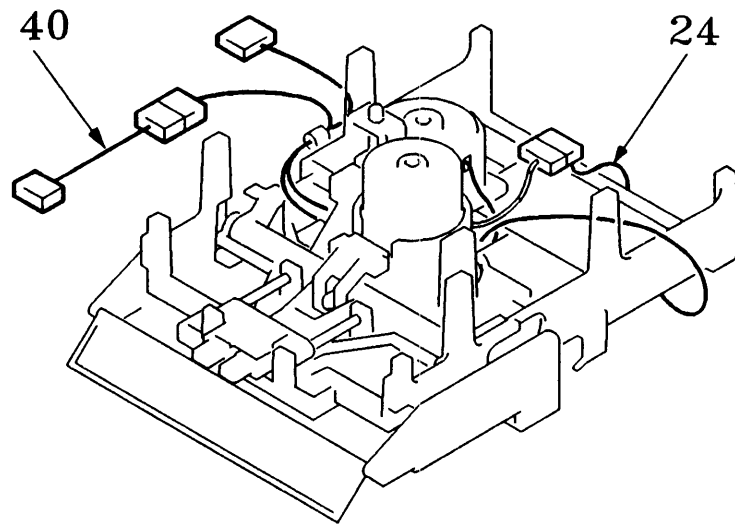
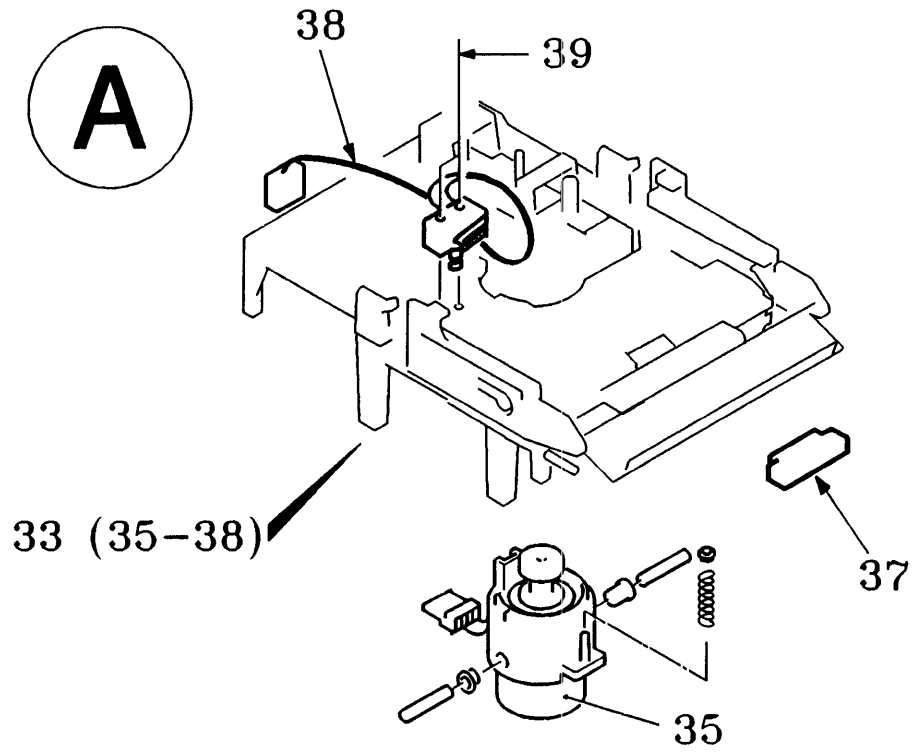

Figure 9-1. HP 9144A Exploded View (sheet 1 of 2)



### View from underside

Figure 9-1. HP 9144A Exploded View (sheet 2 of 2)

Table 9-2. Replaceable Parts

FIG. & INDEX NO.	HP PART NO.	DESCRIPTION	MFR CODE	MFR PART NO.	UNITS PER ASSY
REF	9144A	1/4-inch CARTRIDGE TAPE DRIVE	28480	9144A	REF
1.	09144-88865	*TOP SHROUD ASSEMBLY (Attaching Parts)	28480	09144-88865	1
2.	0515-1079	*SCREW, machine, pnh, pozi, M3.0 by 0.5, 8mm long w/star washer.	00000	OBD	3
3.	3050-0891	*Plain Washer - - - X - - -	00000	OBD	2
4.	09121-48303	**FRONT FOOT	28480	09121-48303	2
5.	0403-0427	**BUMPER FOOT	28480	0403-0427	2
6.	09144-66506	*FRONT PANEL ASSEMBLY (Attaching Parts)	28480	09144-66506	1
7.	0515-1079	*SCREW, machine, pnh, pozi, M3.0 by 0.5, 8mm long w/star washer - - - X - - -	00000	OBD	4
8.	09144-84305	**FRONT PANEL LABEL	28480	09144-84305	1
9.	09144-66506	**FRONT PANEL PCA (Attaching Parts)	28480	09144-66506	1
10.	0524-0314	*SCREW, tapping, pnh, pozi, 4-20 - - - X - - -	00000	OBD	6
11.	09144-61612	**FRONT PANEL CABLE	28480	09144-61612	1
12.	09144-48101	**LED WINDOW	28480	09144-48101	1
13.	09144-47404	**UNLOAD BUTTON	28480	09144-47404	1
14.	09144-61610	*POWER CABLE	28480	09144-61610	1
15.	09133-67120	*POWER SUPPLY UNIT A10 (Attaching Parts)	28480	09133-67120	1
16.	0515-0780	*SCREW (side), machine, pnh, pozi, M4.0 by 8mm long w/star washer	00000	OBD	1
17.	0515-0105	*SCREW (front), machine, pnh, pozi, M3.0 by 15mm long	00000	OBD	1
18.	0380-1724	*SPACER (front) round, .281" long	28480	0380-1724	1
19.	0515-0780	*SCREW (back), machine, pnh, pozi, M4.0 by 0.5, 12mm long - - - X - - -	00000	OBD	1
20.	5041-1203	**KEY CAP, WHITE (for AC line switch)	28480	5041-1203	1
21.	09144-68502	*FAN ASSEMBLY	28480	09144-68502	1
22.	07941-00026	**FAN GRILLE (Attaching Parts)	28480	07941-00026	1
23.	0624-0525	*SCREW tapping, pnh, pozi, 10-14, 16mm long - - - X - - -	00000	OBD	4
24.	09144-61615	*DRIVE MOTOR EXTENDER CABLE	28480	09144-61615	1
25.	09144-69519	*DRIVE ELECTRONICS PCA (Attaching Parts)	28480	09144-69519	1
26.	0380-1656	*STAND OFF SPACER (Plastic)	28480	0380-1656	1
27.	0515-1079	*SCREW, machine, pnh, pozi, M3.0 by 0.5, 8mm long w/star washer.	00000	OBD	1
28.	0380-0643	*STAND-OFF, HEX, 6-32, 0.255in long.	00000	OBD	2
28a.	2190-0017	*WASHER, split lock - - - X - - -	00000	OBD	2
29.	07940-890X0	*EXEC EPROM U132	28480	07940-890X0	1

ReplaceableParts  
9144A

FIG.& INDEX NO.	HP PART NO.	DESCRIPTION	MFR CODE	MFR PART NO.	UNITS PER ASSY
30.	09144-8922X	*UNIT CODE EPROM U18	28480	09144-8922X	1
31.	09144-8981X	*DDC PROCESSOR/ROM U33	28480	09144-8981X	1
32.	09144-8911X	*SERVO PROCESSOR/ROM U305	28480	09144-8911X	1
33.	09144-6950	*DRIVE MECHANISM (Attaching Parts)	28480	09144-6950	1
34.	0515-1079	*SCREW, machine, pnh, pozi, M3.0 by 0.5, 8mm long w/star washer. - - - X - - -	00000	OBD	4
35.	09144-65209	**CAPSTAN MOTOR/TACHO ASSEMBLY (Attaching Parts)	28480	09144-65209	1
36.	0515-0154	**SCREW, set, cup point, M3.0 by 0.5 3mm long - - - X - - -	00000	OBD	2
37.	09144-47402	**EJECT KEY CAP	28480	09144-47402	1
38.	09144-61607	**MICROSWITCHES AND CABLE (Attaching Parts)	28480	09144-61607	1
39.	0515-0334	**SCREW, machine, pnh, pozi, M2.0 by 0.4, 18mm long. - - - X - - -	00000	OBD	2
40.	09144-61616	**HEAD EXTENDER CABLE	28480	09144-61616	1

Table 9-3. Abbreviations

A	= ampere(s)	ID	= inside diameter	qty	= quantity
AC	= alternating current	in.	= inch, inches	rdh	= round head
AR	= as required	incand	= incandescent	rect	= rectifier
assy	= assembly	incl	= include(s)	ref	= reference
brkt	= bracket	intl	= internal	rf	= radio frequency
c	= centi ( $10^{-2}$ )	I/O	= input/output	rfi	= radio frequency interference
C	= Celsius, centigrade	k	= kilo ( $10^3$ ), kilohm	rh	= right hand
cer	= ceramic	kg	= kilogram	rpm	= revolutions per minute
cm	= centimeter	lb	= pound	rwv	= reverse working voltage
comp	= composition	LED	= light-emitting diode	sb	= slow blow
conn	= connector	lh	= left hand	SCR	= semiconductor-controlled rectifier
d	= deci ( $10^{-1}$ )	M	= mega ( $10^6$ ), megohm	scw	= square cone washer
DC	= direct current	m	= milli ( $10^{-3}$ )	Se	= selenium
deg	= degree(s)	mach	= machine	Si	= silicon
dia	= diameter	mb	= medium blow	slftpg	= self-tapping
dpdt	= double-pole, double-throw	met oxd	= metal oxide	spdt	= single-pole, double throw
dpst	= double-pole, single throw	mfr	= manufacturer	spst	= single pole, single throw
elctlt	= electrolytic	misc	= miscellaneous	sst	= stainless steel
encap	= encapsulated	mm	= millimeter	stl	= steel
ext	= external	mtg	= mounting	sw	= switch
F	= Fahrenheit, farad	My	= Mylar	T	= TORX <sup>(R)</sup> screw
fb	= fast blow	n	= nano ( $10^{-9}$ )	Ta	= tantalum
fh	= flat head	n.c.	= normally closed	tgl	= toggle
fig.	= figure	no.	= number	thd	= thread
filh	= fillister head	NSR	= not separately replaceable	Ti	= titanium
flm	= film	ntd	= no time delay	tol	= tolerance
fw	= full wave	OBD	= order by description	U ( $\mu$ )	= micro ( $10^{-6}$ )
fxd	= fixed	OD	= outside diameter	V	= volt(s)
G	= giga ( $10^9$ )	ovh	= oval head	var	= variable
Ge	= germanium	oxd	= oxide	Vdcw	= direct current working volts
H	= Henry, Henries	p	= pico ( $10^{-12}$ )	W	= watt(s)
hd	= head	PCA	= printed-circuit assembly	w/	= with
hex	= hexagon, hexagonal	phh	= phillips head	WIV	= inverse working volts
hlcl	= helical	pnh	= pan head	ww	= wire-wound
Hz	= Hertz	P/O	= part of		
		pot	= potentiometer		
		pozi	= Pozidriv		

TORX<sup>(R)</sup> is a registered trademark of the Camcar Division of Textron, Inc.

This section provides useful reference material including miscellaneous technical data which has been referred to in earlier sections.

## 10-1. OTHER MANUALS

There are a number of manuals written specifically for the HP 9144A Tape Drive. These are as follows:

- 09144-90000 Operators's Manual
- 09144-90012 Operators Manual supplement and Update to the supplement
- 09144-90014 Read this First
- 09144-90030 Hardware Support Manual
- 09144-90039 CE Handbook
- 19500-90902 Rack Mounting Kit Installation Instructions

## 10-2. CHANNEL INTERFACE

Interface to the Tape Drive is accomplished through the Hewlett-Packard Interface Bus (HP-IB) hardware and the CS/80 Instruction Set, a set of commands formulated for mass storage devices. The following paragraphs discuss the types of CS/80 commands. Also provided is an overview of HP-IB. For full details of CS/80, refer to the *CS/80 Instruction Set Programming Manual*, part no. 5955-3442.

## 10-3. CS/80 INSTRUCTION SET

The increase in capabilities of both host computers and mass storage devices has emphasized the need for efficient channel communication. The CS/80 Instruction Set increases the efficiency and speed of channel operations between tape memories and their associated host computers. Tables 10-1 to 10-4, Device Command Summary, provides a summary of all CS/80 instructions. The CS/80 Instruction Set allows a host computer to access special utilities within the Tape Drive. Utilities are routines stored in firmware which allow error rate tests to be performed and the results of such tests to be examined or logged. Utilities are listed in

table 10-5, Tape Drive Utilities. Refer to the *External Exerciser Reference Manual*, part no. 5955-3462, for full details.

## 10-4. TRANSACTION STRUCTURE

A transaction is a logically complete operation between a system host computer and a peripheral device (the Tape Drive) over a given channel (HP-IB). Three phases may occur during each transaction: command, execute, and report. A transaction begins when a command is received by the Tape Drive, and ends when a reporting message indicating the status of the transaction is accepted by the host. Figure 10-1 illustrates the transaction structure, and shows the relationship between the Tape Drive operating states and the channel activity relative to each phase.

A unit is a separately addressable entity within a device (Tape Drive). A volume is a separately addressable portion of the storage media within a given unit.

## 10-5. REAL-TIME COMMANDS

Real-time commands are optimized for execution time. These commands are used most often in host/device transactions. One or more complementary commands may precede a real-time command in order to modify the operation of that command. Real-time commands include: Locate and Read, Cold Load Read, Locate and Write, and Write File Mark.

## 10-6. COMPLEMENTARY COMMANDS

Complementary commands are used to set or update programmable states in the Tape Drive. The programmable states define characteristics such as: set unit, set address, set block displacement, set return addressing mode, set length, set burst mode, set release, set status mask, set volume, set retry time, no op and set device specific options. These



commands may be included within Real-Time, General Purpose, or Diagnostic command messages, or they may stand alone. When a complementary command (or commands) is (are) embedded within another command, the parameters or conditions established by that complementary command(s) are altered only for the duration of the current command. A stand-alone complementary command, however, sets the parameters or conditions until the same stand-alone complementary command alters the set value or until power-on occurs. Power-on resets all complementary commands to their default values. Therefore, at power-on, length is defaulted to equal the entire tape, if one is loaded. A stand-alone Set Length command may give it a "set" value of 1 kbyte to be used for an entire sequence of transactions, although some special case commands could temporarily override this value with an embedded complementary command to set a "current" value of 256 bytes (for 1 frame).

#### **10-7. GENERAL PURPOSE COMMANDS**

This command group includes commands which allow the host to determine device type and operating characteristics or to ascertain storage media integrity. These commands are not considered "real-time" commands and therefore should not be is-

sued by the host unless it is willing to relinquish control of the drive for a varying period of time. General purpose commands are: Locate and Verify, Spare Block, Release, Release Denied, Describe, Initialize Media and Unload.

#### **10-8. DIAGNOSTIC COMMANDS**

Diagnostic commands are intended to assist the host in isolating problems in the device to the replaceable assembly level. Some commands allow protected access to variables or data maintained by the device (such as error information), while others cause tests to be performed within the device, or on a specific area of the storage media. Diagnostic commands may be modified by complementary commands. Initiate Diagnostic, Initiate Utility, and Request Status are all diagnostic commands.

#### **10-9. TRANSPARENT MESSAGES**

Transparent commands compensate for different types of channels and differences in operating environments. Transparent commands are intercepted by the device firmware and modify the normal command-execution-reporting transaction sequence. Transparent commands are explained in the *CS/80 Instruction Set Programming Manual*, part no. 5955-3442.

Table 10-1. Device Real-Time Command Summary

## LOCATE AND READ

**FUNCTION:** Locates the data indicated by the target address and transmits the data to the host.

**OPCODE:**  $0_{10}$  00000000<sub>2</sub> 000<sub>8</sub> 00<sub>16</sub>

**FORMAT:** No variables or parameters

## COLD LOAD READ

**FUNCTION:** Used by the host to bootstrap itself into a higher operating environment from a more primitive state.

**OPCODE:**  $10_{10}$  00001010<sub>2</sub> 012<sub>8</sub> 0A<sub>16</sub>

**FORMAT:** No variables or parameters

## LOCATE AND WRITE

**FUNCTION:** Transfers data from the host for storage beginning at the address specified by the target address.

**OPCODE:**  $2_{10}$  00000010<sub>2</sub> 002<sub>8</sub> 02<sub>16</sub>

**FORMAT:** No variables or parameters

## WRITE FILE MARK

**FUNCTION:** Causes a file mark to be written at the current tape position or any position selected through the use of the Set Address command.

**OPCODE:**  $73_{10}$  01001001<sub>2</sub> 111<sub>8</sub> 49<sub>16</sub>

**FORMAT:** No variables or parameters

Table 10-2. Device Complementary Command Summary

## SET UNIT

**FUNCTION:** Used to specify a specific unit within the device.

**OPCODE:**  $32_{10}$  00100000<sub>2</sub> 040<sub>8</sub> 20<sub>16</sub> unit 0  
 $47_{10}$  00101111<sub>2</sub> 057<sub>8</sub> 2F<sub>16</sub> unit 15 (controller)

**FORMAT:** <0010YYYY>

YYYY = unit number (1111 = device controller)

## SET BLOCK ADDRESS

**FUNCTION:** Used to set the value of the target address and to define the addressing mode.

**OPCODE:**  $16_{10}$  00010000<sub>2</sub> 020<sub>8</sub> 10<sub>16</sub>  
 $17_{10}$  00010001<sub>2</sub> 021<sub>8</sub> 11<sub>16</sub>

**FORMAT:** <0001000T> < P1 > - - - - < P6 >

T = address mode (0 = single vector)  
Single vector format: 6-byte binary number

## SET BLOCK DISPLACEMENT

**FUNCTION:** Adjusts the target address by the number of blocks indicated by the parameter field.

**OPCODE:**  $18_{10}$  00010010<sub>2</sub> 022<sub>8</sub> 12<sub>16</sub>

**FORMAT:** <00010010> < P1 > - - - - < P6 >

Parameter format: 6-byte, signed, two's complement,  
binary number

Table 10-2. Device Complementary Command Summary (continued)

## SET RETURN ADDRESSING MODE

**FUNCTION:** Specifies the address format (single or 3-vector) returned in the parameter field of the status message.

**OPCODE:**  $72_{10}$   $01001000_2$   $110_8$   $48_{16}$

**FORMAT:**  $\langle 01001000 \rangle \langle 00000TTT \rangle$

TTT = addressing mode

000 = single-vector

001 = 3-vector (this is ignored since the addressing mode is single-vector, and single-vector behavior is maintained).

## SET LENGTH

**FUNCTION:** Defines the number of bytes in a data transfer.

**OPCODE:**  $24_{10}$   $00011000_2$   $030_8$   $18_{16}$

**FORMAT:**  $\langle 00011000 \rangle \langle P1 \rangle \text{-----} \langle P4 \rangle$

Parameter format: 4-byte, unsigned, binary number

## SET BURST MODE

**FUNCTION:** Activates and deactivates burst mode.

**OPCODE:**  $60_{10}$   $00111100_2$   $074_8$   $3C_{16}$   
 $61_{10}$   $00111101_2$   $075_8$   $3D_{16}$

**FORMAT:**  $\langle 0011110T \rangle \langle P1 \rangle$

T = 0 Only the last burst is tagged with the message terminator (EOI on HP-IB)

T = 1 All bursts are tagged with the message terminator

P1 = Number of 256-byte segments in each burst (If P1=0, burst mode is deactivated.)

\*

Table 10-2. Device Complementary Command Summary (continued)

## SET RELEASE

**FUNCTION:** Defines how a device will respond to an internal release request.

**OPCODE:**  $59_{10}$   $00111011_2$   $073_8$   $3B_{16}$

**FORMAT:** <00111011> <TZ000000>

T = 1 Suppress release timeout

Z = 1 Release automatically during idle time

## SET STATUS MASK

**FUNCTION:** Provides selective masking of error conditions reported in the status message.

**OPCODE:**  $62_{10}$   $00111110_2$   $076_8$   $3E_{16}$

**FORMAT:** <00111110> <P1> ----- <P8>

The bit positions in the parameter bytes (P1-P8) correspond to the bit positions in the status message. Refer to paragraph 2-45 in the CS/80 Programming Manual.

1 = masked error

## SET VOLUME

**FUNCTION:** Selects a specific volume on the currently selected unit.

**OPCODE:**  $64_{10}$   $01000000_2$   $100_8$   $40_{16}$

**FORMAT:** <01000YYY>

YYY = volume number (volume 0 only)

## NO OP

**FUNCTION:** Causes the device to disregard the message byte.

**OPCODE:**  $52_{10}$   $00110100_2$   $064_8$   $34_{16}$

**FORMAT:** No variables or parameters

Table 10-2. Device Complementary Command Summary (continued)

**SET RETRY TIME****FUNCTION:** Sets amount of time available for read and seek retries.**OPCODE:**  $58_{10}$   $00111010_2$   $072_8$   $3A_{16}$ **FORMAT:**  $\langle 00111010 \rangle \langle P1 \rangle \langle P2 \rangle$ 

P1-P2 = retry time in tens of milliseconds (16-bit binary number)

**SET DEVICE SPECIFIC OPTIONS****FUNCTION:** The command can perform five tasks:

1. In sequential mode it can either load the next tape when one is unloaded, or it can enable a complete media unload.
2. It can enable or disable the tape drive's character count capability. This enables the drive to skip to the next data block when all user data in a given block has been sent.
3. It can enable or disable Auto Sparing.
4. It can choose either Jump or Skip Sparing.
5. It can enable tape streaming operation.

**OPCODE:**  $56_{10}$   $00111000_2$   $070_8$   $38_{16}$ **FORMAT:**  $\langle 00111000 \rangle \langle M0001ASC \rangle$ 

M = 0: Cartridge unload mode (Sequential mode)

M = 1: Media unload mode (Sequential mode)

C = 0: Disable character count capability

C = 1: Enable character count capability

A = 0: Auto sparing disabled

A = 1: Auto sparing enabled

S = 0: Auto spare invokes Jump sparing

S = 1: Auto spare invokes Skip sparing

I = 0: Disable immediate report/command queueing

I = 1: Enable immediate report/command queueing.

The power-up and default value for the options byte is  $00000000_2$ , that is all bits reset.

Table 10-3. Device General Purpose Command Summary

## LOCATE AND VERIFY

**FUNCTION:** Instructs the device to perform an internal verification of a section of data to ensure that it can be read.

**OPCODE:**  $4_{10}$  00000100<sub>2</sub> 004<sub>8</sub> 04<sub>16</sub>

**FORMAT:** No variables or parameters

## SPARE BLOCK

**FUNCTION:** Gives the device permission to become temporarily busy while sparing the block indicated by the target address.

**OPCODE:**  $6_{10}$  00000110<sub>2</sub> 006<sub>8</sub> 06<sub>16</sub>

**FORMAT:** <00000110> <00000S0T><sub>p1</sub>

P1 = sparing mode byte

S = 0 skip spare      S = 1 jump spare

T = 0 retain data      T = 1 do not retain data

T must equal 1 for tape operation

S must equal 0 for tape operation

## RELEASE

**FUNCTION:** Releases the device.

**OPCODE:**  $14_{10}$  00001110<sub>2</sub> 016<sub>8</sub> 0E<sub>16</sub>

**FORMAT:** No variables or parameters

## RELEASE DENIED

**FUNCTION:** Prohibits the device from releasing itself.

**OPCODE:**  $15_{10}$  00001111<sub>2</sub> 017<sub>8</sub> 0F<sub>16</sub>

**FORMAT:** No variables or parameters

Table 10-3. Device General Purpose Command Summary (continued)

**DESCRIBE**

**FUNCTION:** Directs the device to return information about the currently loaded cartridge. It gives a controller description, unit description and a volume description.

**OPCODE:** 53<sub>10</sub> 00110101<sub>2</sub> 065<sub>8</sub> 35<sub>16</sub>

**FORMAT:** All individual fields are 8-bit binary. Numbers are given in hexadecimal unless otherwise stated.

## Controller Description Field (5 bytes)

C1, C2 = 80, 01 (Installed unit type: U0, U15)  
 C3, C4 = 03, E8 (max transfer rate is 1Mbyte per second)  
 C5 = 00

## Unit Description Field (19 bytes)

U1 = 02 (Tape Drive)  
 U2 - U4 = 35, 40, 10 (Model No is 9144A)  
 U5, U6 = 04, 00 (1024 bytes per block)  
 U7 = 0A (10 blocks can be buffered - can vary)  
 U8 = 00 (burst mode not recommended)  
 U9, U10 = 75, 30 (30 000 microseconds block to block)  
 U11, U12 = 00, 23 (35 000 bytes per second ave. transfer rate)  
 U13, U14 = 00, 0A (100 milliseconds is the optimal retry time)  
 U15, U16 = 5D, C0 (24 000 milliseconds)  
 U17 = 00 (maximum interleave factor)  
 U18 = 00 (no fixed volumes)  
 U19 = 01 (removable volumes)

## Volume Description Field (13 bytes)

V1 - V6 = all 00 (the tape drive does not support 3 vector addressing)  
 V7 - V12 = 00, 00, 00, 00, nn, nn Maximum block address (nn, nn) is either:

FF, FF (65535 - 600foot tape, no spares)  
 FF, 7F (65407 - 600foot tape with spares)

3F, FF (16383 - 150foot tape, no spares)  
 3F, DF (16351 - 150foot tape with spares)

00, 00 (no tape loaded in drive)

V13 = 00 (current interleave is 0)



Table 10-3. Device General Purpose Command Summary (continued)

## INITIALIZE MEDIA

**FUNCTION:** Initializes all the data fields of the currently selected unit.

**OPCODE:**  $55_{10}$   $00110111_2$   $067_8$   $37_{16}$

**FORMAT:**  $\langle 00110111 \rangle \langle 00000CWZ \rangle_{p1} \langle P2 \rangle$

P1 = initiate options byte

Options for tape media:

CWZ = 000 Retain both factory (primary) and field  
(secondary) spares

CWZ = 001 Retain factory spares only

CWZ = 010 Retain no spares (for CE use only)

P2 = Block interleave byte

## UNLOAD

**FUNCTION:** Causes the drive mechanism to perform an unload sequence.

**OPCODE:**  $74_{10}$   $01001010_2$   $112_8$   $4A_{16}$

**FORMAT:** No variables or parameters

Table 10-4. Device Diagnostic Command Summary

## INITIATE DIAGNOSTIC

**FUNCTION:** Directs the device to perform one internally defined diagnostic routine.

**OPCODE:**  $51_{10}$   $00110011_2$   $063_8$   $33_{16}$

**FORMAT:**  $\langle 00110011 \rangle \langle P1 \rangle \langle P2 \rangle \langle P3 \rangle$

P1-P2 = loop parameter  
P3 = diagnostic section number

## INITIATE UTILITY

**FUNCTION:** Directs the device to perform one utility routine.

**OPCODE:**  $48_{10}$   $00110000_2$   $060_8$   $30_{16}$   
 $49_{10}$   $00110001_2$   $061_8$   $31_{16}$   
 $50_{10}$   $00110010_2$   $062_8$   $32_{16}$

**FORMAT:**  $\langle 001100XX \rangle \langle P1 \rangle \langle n \text{ parameter bytes} \rangle$

XX = execution message qualifier  
 00 = no execution message  
 01 = device will receive execution message  
 10 = device will send execution message

P1 = utility number (device specific)

There can be up to 8 bytes in the parameter field. The number and content of these bytes is determined by P1.

Information about the individual Tape Drive Utilities is found in Table 10-5.

## REQUEST STATUS

**FUNCTION:** Instructs the device to return (in an execution message) the status report.

**OPCODE:**  $13_{10}$   $00001101_2$   $015_8$   $0D_{16}$

**FORMAT:** No variables or parameters

Table 10-5. Tape Drive Utilities

## Pattern Error Rate Test <C8> Hex

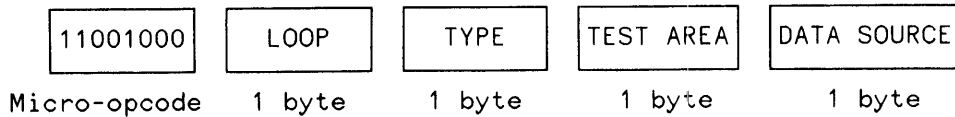

### Parameter Definition:

LOOP → 0-255 = Loop Count

TYPE → 00 = Read Only ERT  
 01 = Write/Read ERT  
 02 = Certification (Read-after-write with bad blocks spared after test done)

TEST AREA → 00 = Use Current Address & Current Length (Logical)

X1 = Use Current and Next Track Test is performed starting on first block of track X and continues for the length of 2 tracks. If track 15 (F) is specified, test will be done on tracks 14 and 15. All blocks on two tracks are tested.

02 = Entire Tape (Physical)

DATA SOURCE → 0-255 Defines data source

00 = Use Internal Pattern Table (8 patterns corresponding to loop number modulo 8)

01 = Use User Defined Pattern (patterns received via the Receive User Pattern Utility)

02 = Use Random Data

The internal patterns, in order, are:

<u>Pattern</u>	<u>Function</u>
B6 6D DB	MFM DC offset
7F	Standing wave
77	Standing wave
55 49 3F	Frequency sweep
FF	Produces 2F in one phase
00	Produces 2F in other phase
55	Produces 1F in one phase
AA	Produces 1F in other phase

Table 10-5. Tape Drive Utilities (continued)

## Read Error Summary <C1> Hex

The Tape Drive returns 64 bytes of 0s in response to this command because the drive mechanism does not support Error Summary Usage due to its comprehensive diagnostic capabilities.

## Read Revisions Number <C3> Hex

This utility returns the firmware revision number to the Host. Four bytes of data are returned. The first byte is always 3, indicating that there are three bytes of data following. The second byte holds the revision number for the Executive ROM. The third byte holds the revision number for the Tape Drive Unit code and the fourth byte holds the number for the Drive Mechanism Unit code.

Bytes 2 and 3 are simple 8 bit numbers.

Byte 4 is of the form:

```
bits 7-4 =Revision number
      3-0 =Rework number
```

## Read Drive Tables <C4> Hex

One of three drive tables is returned to the Host based on the micro-opcode which follows the utility opcode.

### a. Manufacturer's block <0A> Hex

This table is written by 3M when the tape is formatted. It contains manufacturer's information about the tape. Unlike the other blocks on the tape it is written in the same direction on all tracks (moving towards EOT) between keys zero and one.

The format of the table is:

```
<cr><lf>DC6xxHC      xx = 00 for the long tape
                      15 for the short tape
<cr><lf>1024
<cr><lf>FORMAT () 1980, MINN. MINING & MFG.CO.
<cr><lf>xxxxxxxxnnnnnnnn
<cr><lf><esc>
```

<cr> represents a carriage return character

<lf> Line Feed

<esc> Escape

xxxxxx is the manufacturers control code

nnnnnnnnnn is the Date code

The cartridge identification code (xxxxxxxxnnnnnnnn) contains both numeric and alphabetic characters and is unique for each cartridge.

Table 10-5. Tape Drive Utilities (continued)

### **b. Spares Table <08> Hex**

The blocks which have been spared either by Certification, Autosparing or by the Host issuing a Spare Block command are returned. The format of the data is as follows :

Number of entries ..... 1 byte  
Table record  
  Key number ..... 2 bytes  
  Track ..... 1 byte  
  for each entry

Note that the table returned in response to this utility shows only bad blocks that have been spared out. It does not show blocks that have been reserved as spares.

### **c. Copy Start Address <0C> Hex**

This table is 6 bytes of zeroes. (On cartridges recorded by a single controller on 7914 Drives the starting address for multiple tape backups is returned.)

If this command is sent to the Tape Drive, illegal parameter will be set in the Request status summary.

## **Read Error Log <C5> Hex**

(also referred to as Runtime Error Log or just Runtime Log.)

This utility returns to the Host the Runtime Error Log, which is an accumulation of runtime errors detected by the drive since the last Clear Logs command. The format of the log is shown next.

Number of records ..... 1 byte  
Number of uncorrectable errors .... 1 byte  
Number of key errors ..... 1 byte  
Type of certification ..... 1 byte

- 0 - not certified
- 1 - 3M certified
- 2 - HP factory certified
- 4 - 7914 Drives certified
- 8 - Tape Drive/drive mechanism certified

Address entries - same format as the Error Rate Test Log.

Table 10-5. Tape Drive Utilities (continued)

## Read Error Rate Test Log <C6> Hex

11000110

Micro-opcode

00000000

Parameter = 0

The ERT Data Error Log is the standard log for all errors found while executing the Pattern Error Rate Test. The log is composed of a header which contains the number of blocks accessed and error counts, and records which contain relevant addresses and error qualifiers. This log contains data and key errors, and is kept separate from the Runtime Error Log so that cumulative errors are not a concern during testing. Records are kept for permanent errors (correctable and uncorrectable) and key errors.

Log Format:

### LOG HEADER

No of records ..... 1 byte  
 No of blocks accessed ..... 4 bytes  
 No of permanent errors ..... 2 bytes  
 No of transient errors ..... 2 bytes  
 No of uncorrectable errors .. 1 byte  
 No of permanent key errors .. 1 byte

Address entries - 3 bytes for each of the records. Each entry is of the form:

Logical address ..... 2 bytes (MSB,LSB)  
 Error byte ..... 1 byte  
 <7 6 5 4 3 2 1 0 >

The Error byte is a bit-map with bits 0 - 5 corresponding to Frames 1-6. A **1** in any of these positions indicates that the frame had a CRC error. Bit 6 is set if the data is uncorrectable. Bit 7 is set if there was a Key error.

## Read Use Log <C7> Hex

This utility returns the Use Log to the Host. This log is never cleared so that an accurate record of all tape usage is recorded here. Note that it is not possible to update this log if the tape is write-protected and thus all sessions may not be reflected in this log. The format of the Use Log appears next.

Number of times tape was loaded .... 2 bytes  
 Number of blocks accessed ..... 4 bytes

Also if the tape drive receives a Clear command, all the accumulated data not written to the tape is lost.

Table 10-5. Tape Drive Utilities (continued)

## Clear Logs <CD> Hex

This utility clears the logs indicated by the parameter byte.

- 0 - Clear both the Error Rate AND the Runtime Error Log
- 1 - Clear ONLY the Error Rate Log

## Preset Drive <CE> Hex

When the drive receives this utility, it updates the Runtime Error Log if it needs updating.

## Receive User Pattern <D1> Hex

This utility allows the Host to send 64 bytes of data which are replicated 16 times (1k total) per block of data written to the tape. This utility is used in conjunction with the Pattern Error Rate Test.

## Read Memory <30> Hex <Address MSB>

Returns 1024 bytes of data, to the Host, starting at memory address <MSB><00>.

## Return Servo Status <36> Hex

The unit reads the current servo status from the Servo I/O port and returns this byte. The servo status is elaborated below.

<u>Status</u>	<u>Description</u>
1XH	Going reverse on track X
2XH	Going forward on track X
3XH	Stopped on track X
40H	Illegal command
41H	Tach/encoder error
42H	Current limit
44H	Edge find fault
48H	Key fault
50H	Speed calibration fault
64H	End of tape
68H	Beginning of tape

Table 10-5. Tape Drive Utilities (continued)

**Set Amplifier gain <37> Hex**

Allows the Host to set the gain of the Read channel amplifier. The parameter byte is the gain value in hexadecimal.

**CAUTION**

THIS COMMAND MAY HAVE CATASTROPHIC RESULTS.

**Return Amplifier Gain <38> Hex**

Returns 1 byte to the Host. This byte is the gain setting of the Read Amplifier (hexadecimal). The value returned is the value obtained using the lower write gap.

**Send Servo Command <3A> <XX> Hex**

This routine passes the Servo command to the Servo microprocessor.

A listing of the Servo commands is presented below. The commands are grouped according to their command type. The command abbreviation, hexadecimal code, and a description of each command are given.

**Normal Operation Commands**

Command Abbrv.	Hex Code	Description
REV/TRK	1/T	Move tape in the reverse direction on track T
FWD/TRK	2/T	Move tape in the forward direction on track T
STOP/TRK	3/T	Stop the tape on track T
SPD60	81	Set the tape speed to 60 ips
SPD90	82	Set the tape speed to 90 ips

**Special Function Commands**

Command Abbrv.	Hex Code	Description
SPDCAL	48	Calibrate tape speed to 60 ips
PREPOS	50	Pre-position both gaps on tape, approx. track 0
EDGE	60	Find edge of tape, put bottom gaps on track 0
UNLOCK	84	Unlock cartridge
STEPSU	A/N	Step head up N steps
STEPO	B/N	Step head down N steps



Table 10-5. Tape Drive Utilities (continued)

### Transparent Commands

Command Abbrv.	Hex Code	Description
INIT	00	Exit power on state
AC600	43	Set acceleration/deceleration rate to 600 ipsps
AC800	44	Set acceleration/deceleration
ESPOOL	45	Enable unspool detection
DSPPOOL	46	Disable unspool detection

### Utilities/Diagnostic Commands

Command Abbrv.	Hex Code	Description
RNS	C1	Return number of steps to edge of tape.
SC0	C2	Select channel 0, override track based select
SC1	C3	Select channel 1, override track based select
LWH	C4.XX	Loopback diag., set status to compl. of xx
TSM	C5	Test servo motor circuit
TST	C6	Test servo tach circuit
THS	C7	Test head stepper circuit
TMP	C8	Test microprocessor (6805)

### Set Retry Mode <3B> <XX> Hex

Allows the Host to specify one of four Retry modes, where XX =

**<00> 7914 Drives compatible - the Default Mode.**

Retry blocks with two or more single permanent errors which cause the data to be unrecoverable until the data is recoverable, or the retry count expires. Retry bad keys as well. Perform auto-sparing as needed for writes based on the current options byte.

**<01> Retry all write errors.**

Retry blocks with one or more single permanent errors until the errors are no longer present or the retry count expires during writes ONLY. Retry bad keys also. Perform autosparing as needed for writes based on the current Options byte.

**<02> Retry and spare write errors.**

Retry all write errors with Auto-sparing invoked if the retry count expires.



**<03> Diagnose errors.**

Retry bad keys and any frame errors for reads AND writes until the errors go away OR the retry count expires.

## **10-10. HEWLETT-PACKARD INTERFACE BUS**

The Hewlett-Packard Interface Bus (HP-IB) provides a standardized method of connecting separate devices (see figure 10-2). The HP-IB per-

mits transfer of commands and data between the components of a system on 16 signal lines. The interface functions for each system component are performed within the component so only passive cabling is needed to connect the system. The cable connects all controllers and other devices of the system in parallel.

TRANSACTION PHASE	CHANNEL ACTIVITY	UNIT OPERATING STATE
COMMAND	<b>2</b> 	<b>1</b> Command-Ready <b>3</b> Accept and validate command Note: Logical machine goes to report state <b>12</b> if command is invalid, or if host requests reporting message.
EXECUTION	<b>6</b> Execution Message Request (if applicable) <b>7</b> 	<b>4</b> Begin execution of command <b>5</b> Request execution message (if applicable) <b>8</b> Complete execution of command (send data, receive data, or accomplish command action) <b>9</b> Compute transaction status
REPORTING	<b>11</b> Reporting Message request <b>12</b> 	<b>10</b> Request reporting message <b>13</b> Send one-byte report (QSTAT)

- (1) Logical Machine idle in command-ready state.
- (2) Host sends command message.
- (3) Logical Machine accepts and verifies command. If command is valid, Logical Machine moves to execution state. If not, Logical Machine moves to reporting state.
- (4) Unit begins execution of command.
- (5,6) If command involves data transfer, Logical Machine requests an execution message. If not, unit completes execution (6).
- (7) Execution message is established if command involves a data transfer.
- (8) Unit completes execution of command. If command involves data transfer, unit sends or receives data through channel module. If not, unit completes action called for in command message.
- (9) Logical Machine computes completion status of transaction. Pass/Fail status is set into QSTAT, complete status set into request status.
- (10,11) Logical Machine requests reporting message.
- (12) Reporting message is established.
- (13) Logical Machine sends 1-byte reporting message (QSTAT) indicating Pass/Fail status of transaction. Host must send request command for complete status report (20 bytes).

Figure 10-1. Transaction Structure

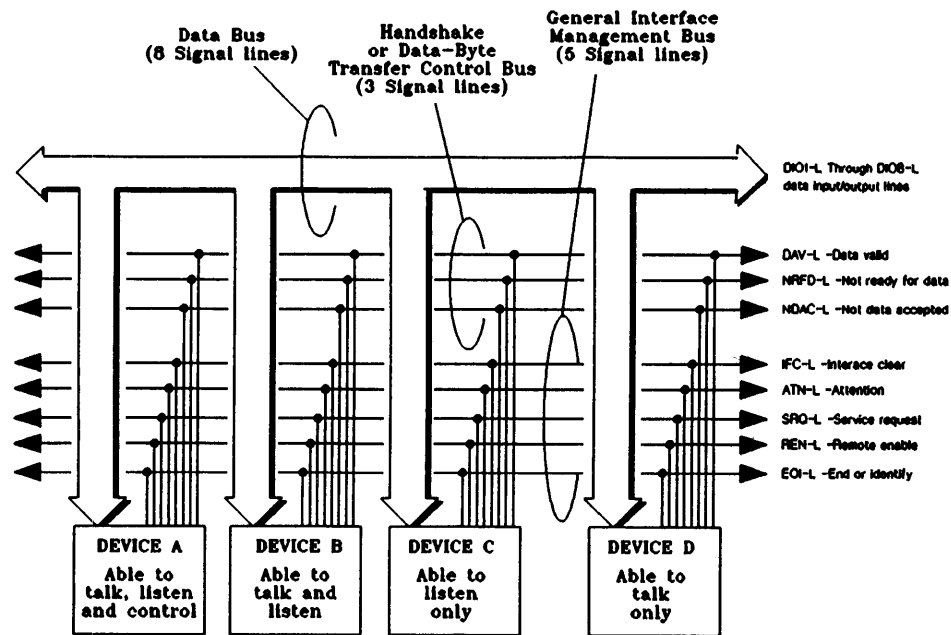

Figure 10-2. Hewlett-Packard Interface Bus Signal Lines

The Hewlett-Packard Interface Bus (HP-IB) has certain rules which must be followed for successful installation of the Tape Drive. Cabling is limited to 1 meter per HP-IB load. Typically the Central Processing Unit (CPU) is 7 equivalent loads and the Tape Drive is 1 equivalent load.

The CPU adheres to an HP standard which allows 7 meters of HP-IB cable between the CPU and the nearest device connected to it and 1 meter of cable between each additional device. The maximum configuration is eight devices (not including CPU) per HP-IB channel or a maximum of 15 meters or 15 equivalent loads.

The eight Data I/O lines are reserved for the transfer of commands, data, and other messages in a Byte-serial, bit-parallel manner. Data and message transfers are asynchronous, coordinated by three handshake lines: Data Valid (DAV-L), Not Ready For Data (NRFD-L), and Not Data Accepted (NDAC-L). The other five lines are for bus management.

Information is transmitted on the data lines under sequential control of the three handshake lines (DAV-L, NRFD-L and NDAC-L). No step in the sequence can be initiated until the previous step has been completed. Information transfer can proceed as fast as devices can respond, but no faster than allowed by the slowest device presently

addressed. This permits several devices to receive the same message byte concurrently.

Devices connected to the bus may be talkers, listeners, or controllers (refer to table 10-6). The Controller-In-Charge (CIC) dictates the role of each of the other devices by setting the Attention (ATN-L) line low and sending talk or listen addresses on the data lines. Addresses are set for each device at the time of system configuration. While the ATN-L line is low, all devices must listen to the data lines. When the ATN-L line is high, devices that have been addressed will send or receive data; all others ignore the data lines. Several listeners can be active simultaneously but only one talker can be active at a time. Whenever a talk address is put on the data lines (while ATN-L is low), all other talkers will be automatically unaddressed.

The Interface Clear (IFC-L) line places the interface system in a known quiescent state. The Remote Enable (REN-L) line is used to select between two alternate sources of device programming data such as the front panel or the HP-IB. The End Or Identify (EOI-L) line is used to indicate the end of a multiple-byte transfer sequence. In addition, when a controller-in-charge sets both the ATN-L and EOI-L lines low, each device capable of a parallel poll responds on the DIO line assigned to it.

Table 10-6. HP-IB Definitions

HP-IB Term	Definition	Considerations
<b>TALKER</b>	Any device which sends information over the HP-IB.	There can be only one TALKER sending information over the HP-IB at a time.
<b>LISTENER</b>	Any device which receives information over the HP-IB. Some devices can function as LISTENERS or TALKERS.	In a parallel poll system, there can be up to 8 LISTENERS receiving information over the HP-IB at the same time.
<b>CONTROLLER</b>	Any device that has been programmed to manage data flow between the TALKER and the LISTENER(s) in addition to being a TALKER and a LISTENER.	The CONTROLLER manages data flow by addressing one device as a TALKER and one or more devices as LISTENERS. There can be only one active CONTROLLER on the HP-IB at any time. The active CONTROLLER is called the CONTROLLER-IN-CHARGE (CIC).
<b>SYSTEM CONTROLLER</b>	Any device that functions as a CONTROLLER and is able to gain absolute control of the HP-IB with the Interface Clear (IFC) signal.	There can be only one SYSTEM CONTROLLER connected to the HP-IB.

## 10-11. HP-IB COMMUNICATIONS

This section describes the formats and sequences for the HP-IB commands, messages and transactions that occur between the Controller-In-Charge (CIC) and the Tape Drive. The following list explains the terms used in this section.

**COMMAND** • A parcel of information transmitted over the channel (HP-IB) relating to a specific operation. Channel commands (usually a single byte) are used to manage operations on the interface channel. Device commands (usually more than one byte) are used to control the operation and are contained within the text of a command message.

**UNIVERSAL COMMAND** • A channel command that causes all devices on the bus to perform a predetermined interface function. Refer to table 10-7.

**PRIMARY COMMAND** • The primary I command is a channel command that begins the message sequence. It contains the command to listen or talk and the address of a particular device. The primary II command terminates the message with an unlisten or untalk command.

Table 10-7. Universal Command Formats

Universal Command	Universal Device Clear
ATN [P001CCCC]	ATN [P00010100]
P=Parity Bit CCCC=Command Code	P=Parity Bit

**SECONDARY COMMAND** • The secondary command sets up the action required of the Tape Drive in the text of the message.

**TEXT** • The text of the message can be 1 to n bytes depending on the required action. The required action can be to receive further qualifying information or instructions (such as a device command), to receive write data, to send read or status data, or to perform a specific operation such as a CLEAR.

**MESSAGE** • A unique sequence of command and text bytes transmitted over the channel during which the communication link between the devices (for example, CIC and the Tape Drive) remains unbroken.

**COMMAND MESSAGE** • A single message containing all the information required to address a device and initiate an operation, set up a programmable parameter, or set up an operation to be executed by an execution message.

**EXECUTION MESSAGE** • A single message containing all the information required to carry out an operation previously set up by a command message.

**TRANSACTION** • A complete process or operation carried out over the channel. Some transactions are completed with only a command/report message, and some require a command, execution, and a reporting message.

## 10-12. CHANNEL MANAGEMENT

The following techniques are used by the CIC to manage the HP-IB: Parallel Poll and Universal Device Clear.

### 10-13. PARALLEL POLL

The CIC conducts a parallel poll on the HP-IB by asserting ATN-L and EOI-L simultaneously. Each device requiring service can then respond by assert-

ing the DIO line corresponding to its address. The CIC then addresses only the device requiring service. If more than one device requires service, the CIC addresses the device with the highest priority (lowest address) first. Parallel Poll Enable (PPE) and Parallel Poll Disable (PPD) are internal states of the Tape Drive controller. PPE occurs when the Tape Drive requires service from the CIC. PPD is the opposite state and occurs whenever the Tape Drive is active (for example, busy executing a command) or idle. A Parallel Poll Response (PPR) from the Tape Drive will occur if the CIC asserts both ATN-L and EOI-L and if the Tape Drive is in the PPE state.

### 10-14. UNIVERSAL DEVICE CLEAR

A universal command is a channel command that causes all devices on the HP-IB to perform a predetermined interface function. Universal Device Clear erases information stored in the Tape Drive controller and places the Tape Drive in a known reset state. The universal device clear format is shown in table 10-7.

### 10-15. MESSAGE STRUCTURE

Each message contains the following components (refer to table 10-8).

- Primary I Command  
(unidirectional from CIC to device)
- Secondary Command  
(unidirectional from CIC to device)
- Text (bi-directional)
- Primary II Command  
(unidirectional from CIC to device)

The CIC asserts ATN-L during primary and secondary commands to distinguish them from text information. The Tape Drive decodes the information contained in both the primary I and secondary commands to prepare for action specified in the text.

This section describes the differences between earlier models of the HP 9144A and the latest version documented in the main body of this manual.

There are four distinct earlier versions of the HP 9144A:

- 5 PCA (HDC, DDC1, DDC2, R/W, S)
- 4 PCA (HDC, DDC, R/W, S)
- 3 PCA (SBCONT, R/W, S)
- 2 PCA (SBCONT, RWS)

HDC - Host Dependent Controller  
DDC - Device Dependent Controller  
SBCONT - Single Board Controller  
R/W - Read Write  
S - Servo  
RWS - Read Write Servo  
PSU - Power Supply Unit

## 11-1. 5 PCA VERSION

When the Tape Drive was first released (beginning with serial prefix number 2418A) it had five PCAs as well as the power supply PCA.

It was functionally the same as the present version but used more, simpler circuitry. Some of the Read/Write and Servo circuitry used analogue techniques, which have now been replaced by digital circuits.

The replaceable parts which differ from the present version include:

07940 - 60195 HDC PCA  
09144 - 68702 Double DDC PCA  
09144 - 66513 R/W PCA  
09144 - 66517 S PCA  
09144 - 60094 PSU PCA  
09144 - 04401 Chassis  
09144 - 61601 Cable DDC - R/W - S  
09144 - 61602 Cable Power  
09144 - 61605 Cable DDC - Front Panel PCA  
09144 - 61606 Cable HDC - DDC

The layout of the major electronic assemblies is shown in figure 11-1. Figures 11-2 to 11-5 show the PCAs. Figures 11-6 to 11-8 show the interconnections between the PCAs. The connections between the two DDC PCAs are not shown, but consist of a single 100-way connector (J5).

Figure 11-9 shows the order of disassembly. When using this chart refer to section 6 for appropriate safety warnings and cautions.

Table 11-1 shows the Diagnostic/Self-Test Errors (which are displayed as a result of performing self-tests) and their interpretation. Table 11-2 shows the Run-Time Drive Errors (which may occur at any time, as the result of a fault) and their interpretation.

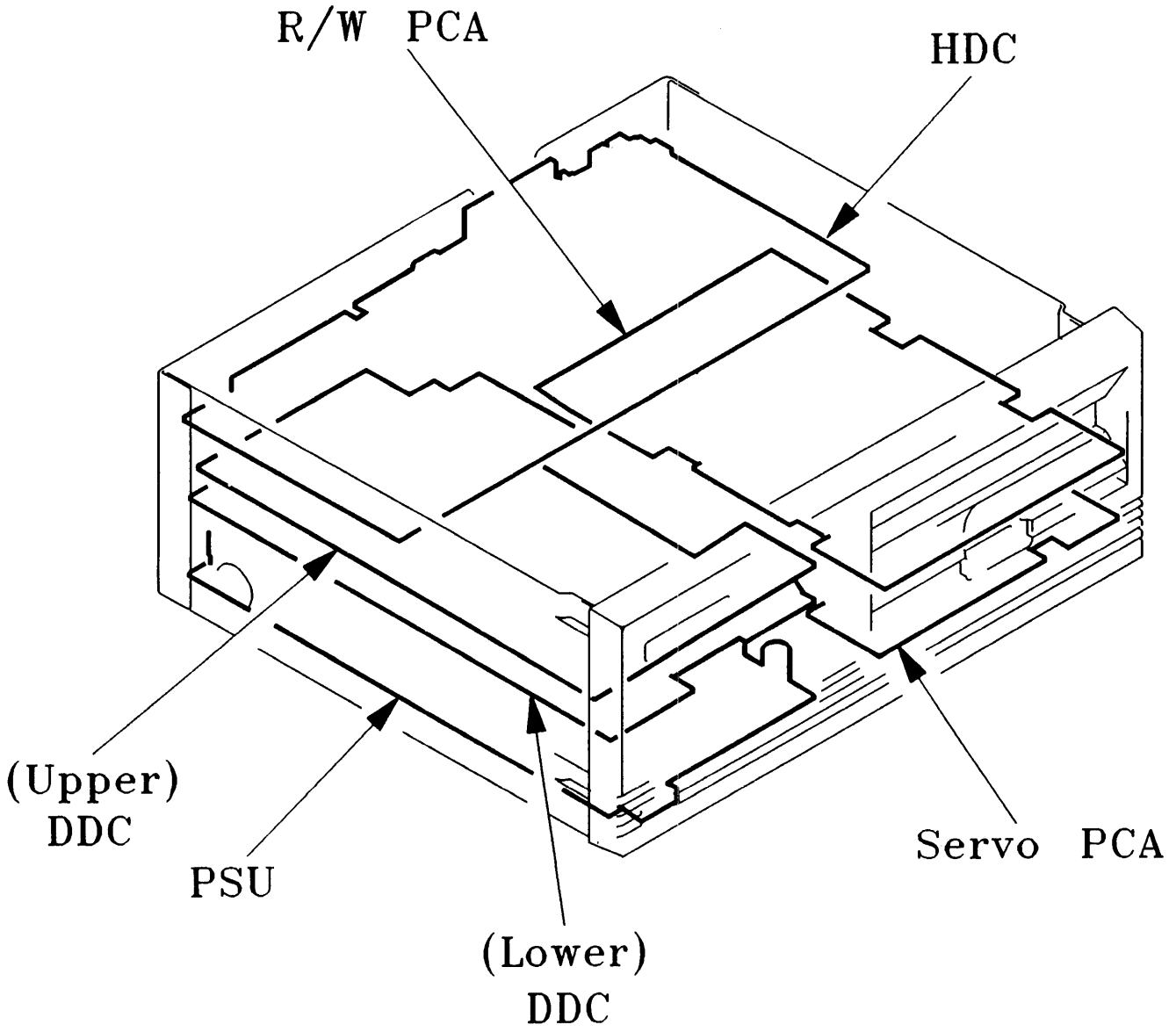

Figure 11-1. Location of PCAs (5 PCA version)



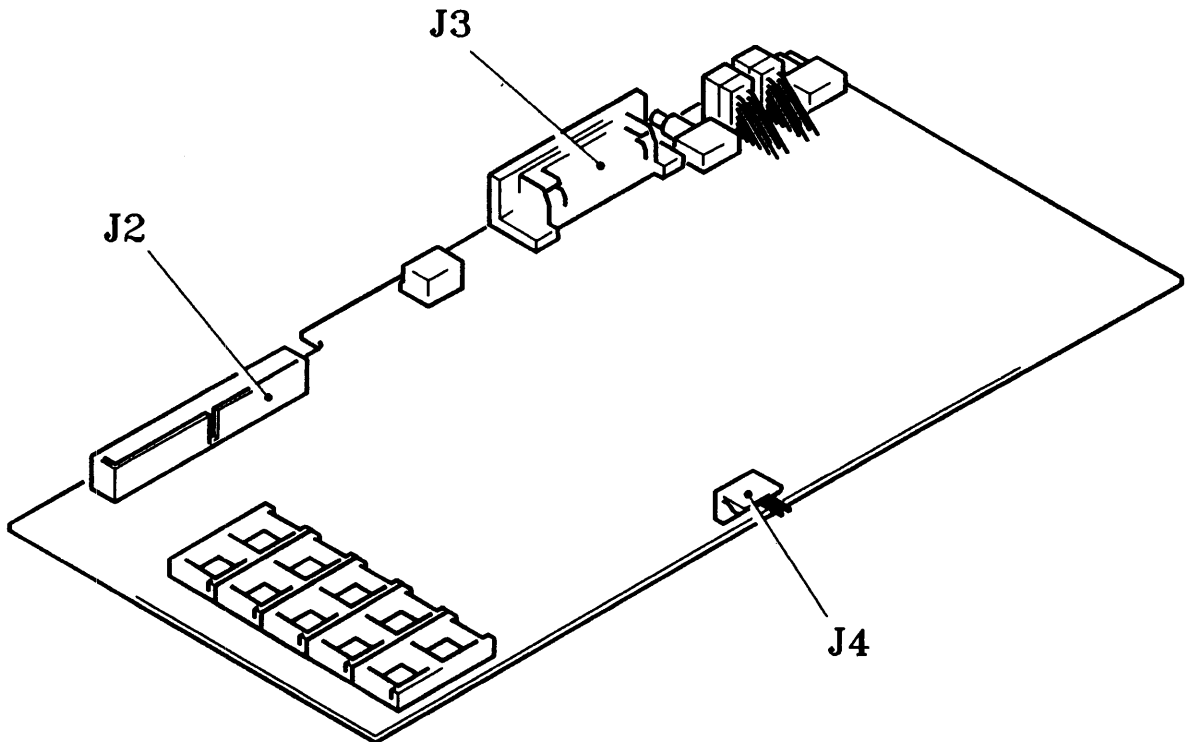

Figure 11-2. The HDC PCA (5 PCA version)

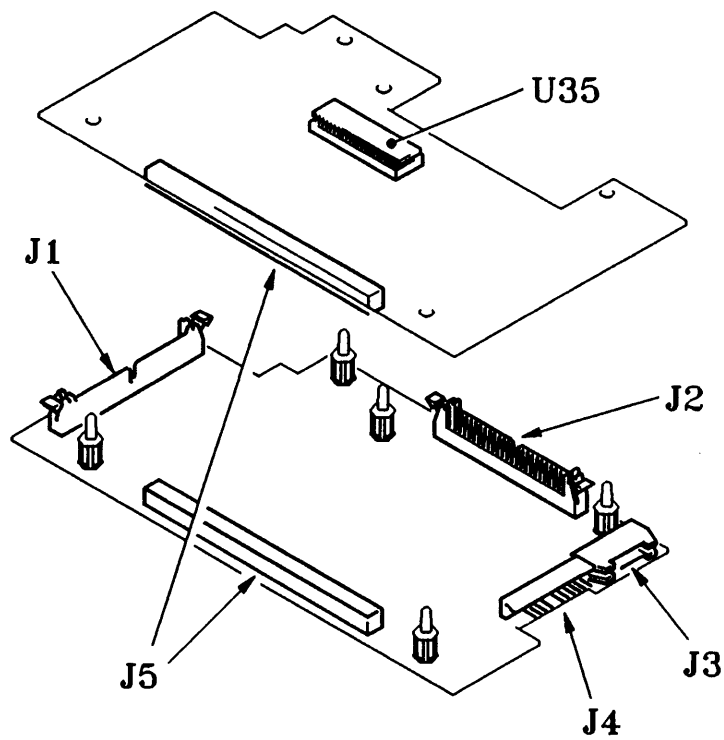

Figure 11-3. The DDC PCAs (5 PCA version)

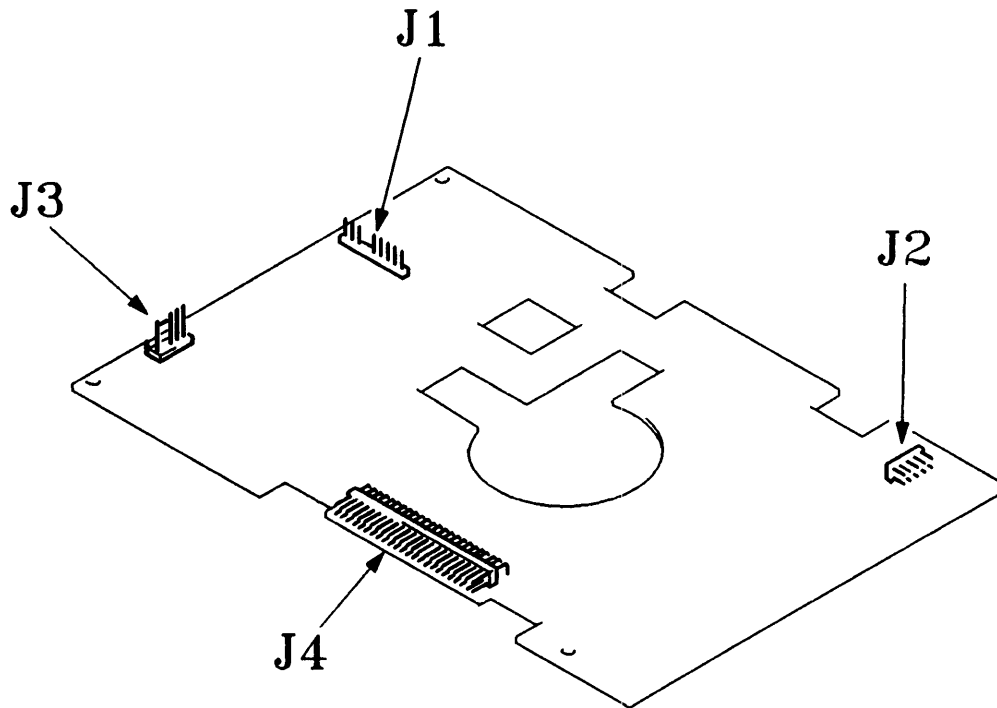

Figure 11-4. The R/W PCA (5 PCA version)

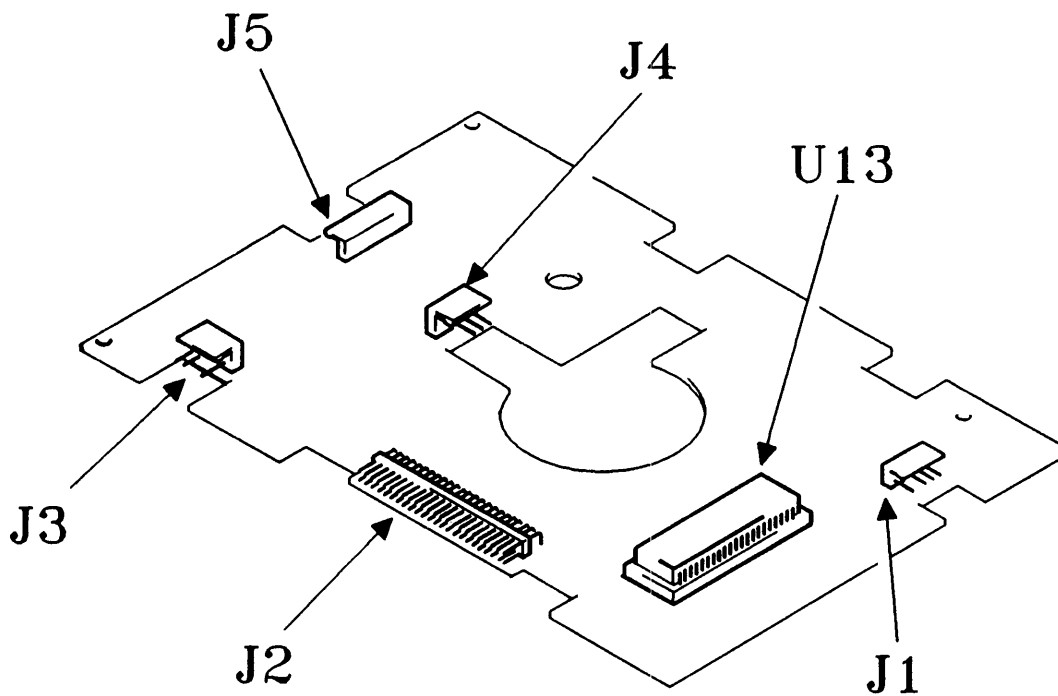

Figure 11-5. The Servo PCA (5 PCA version)

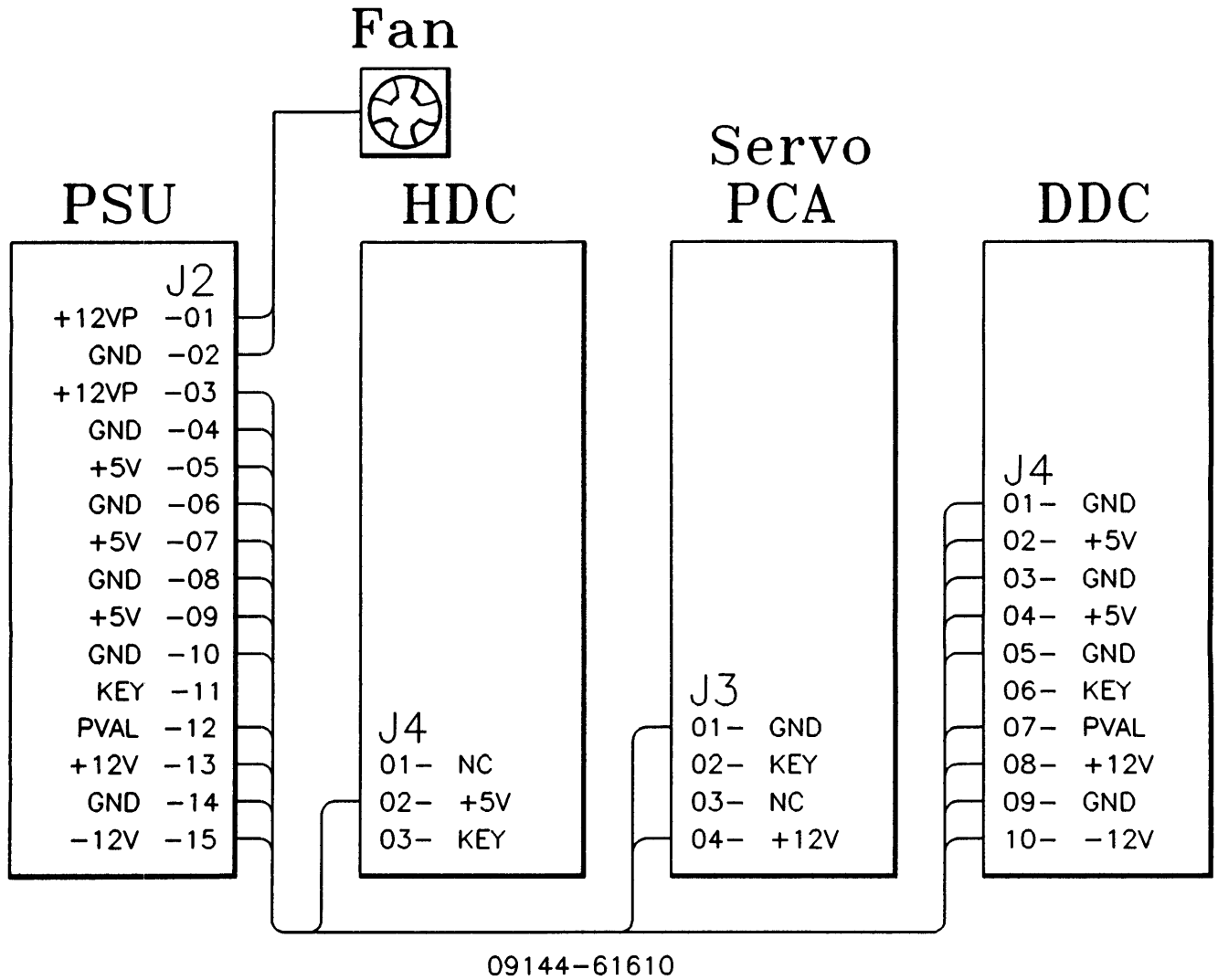

Figure 11-6. Power Cabling (5 PCA version)

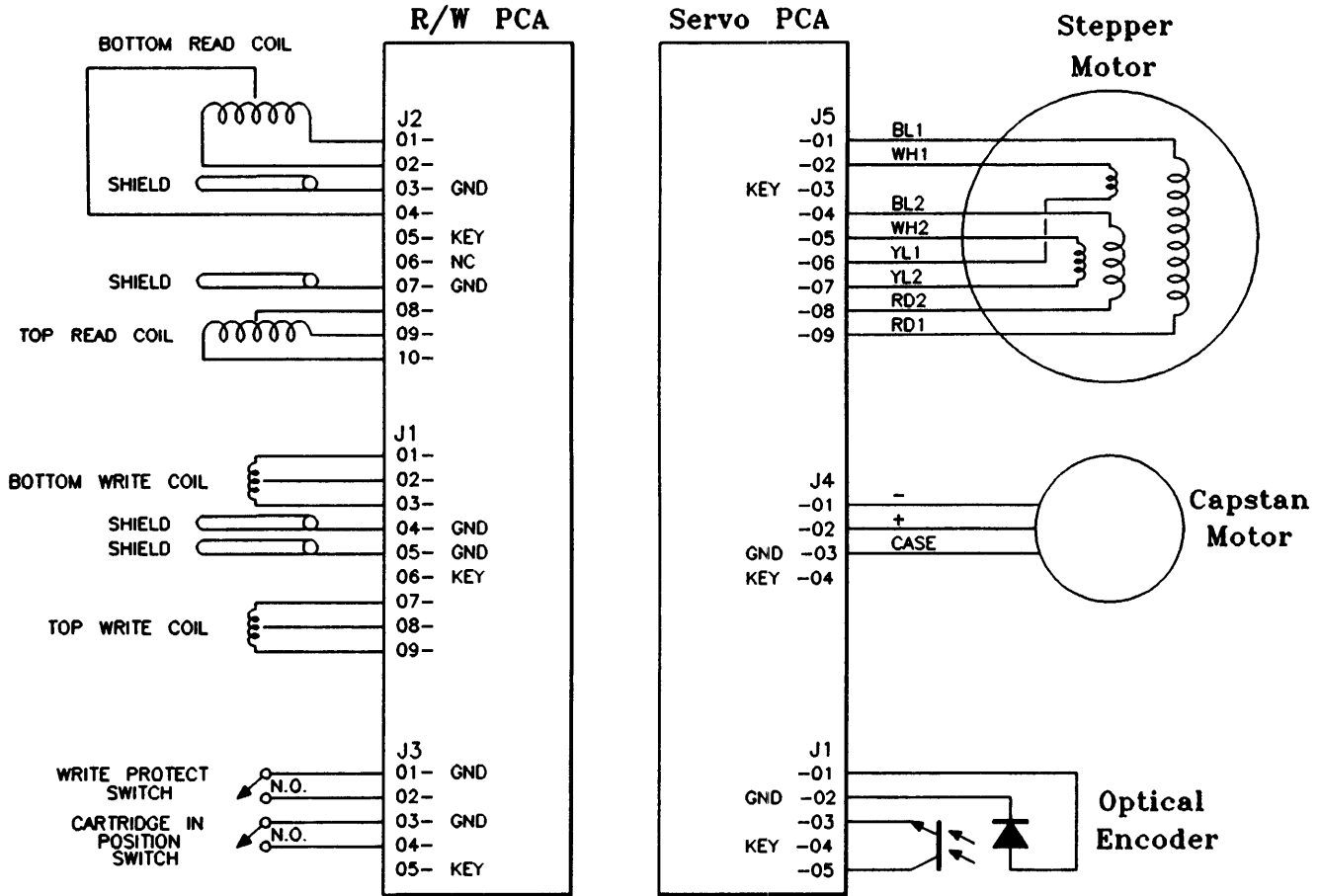

Figure 11-7. Drive Mechanism cabling (5 PCA version)

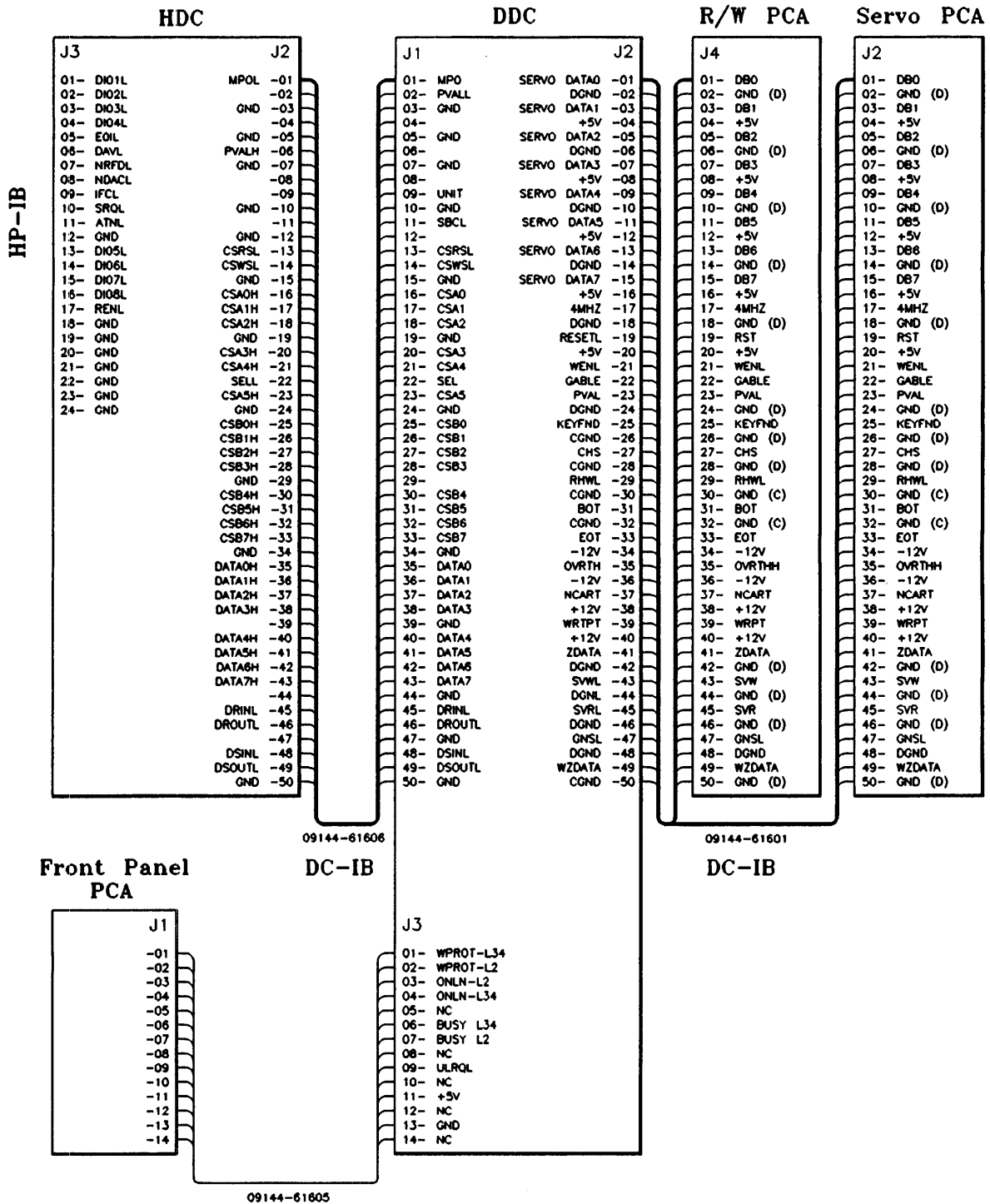

Figure 11-8. Signal Cabling (5 PCA version)

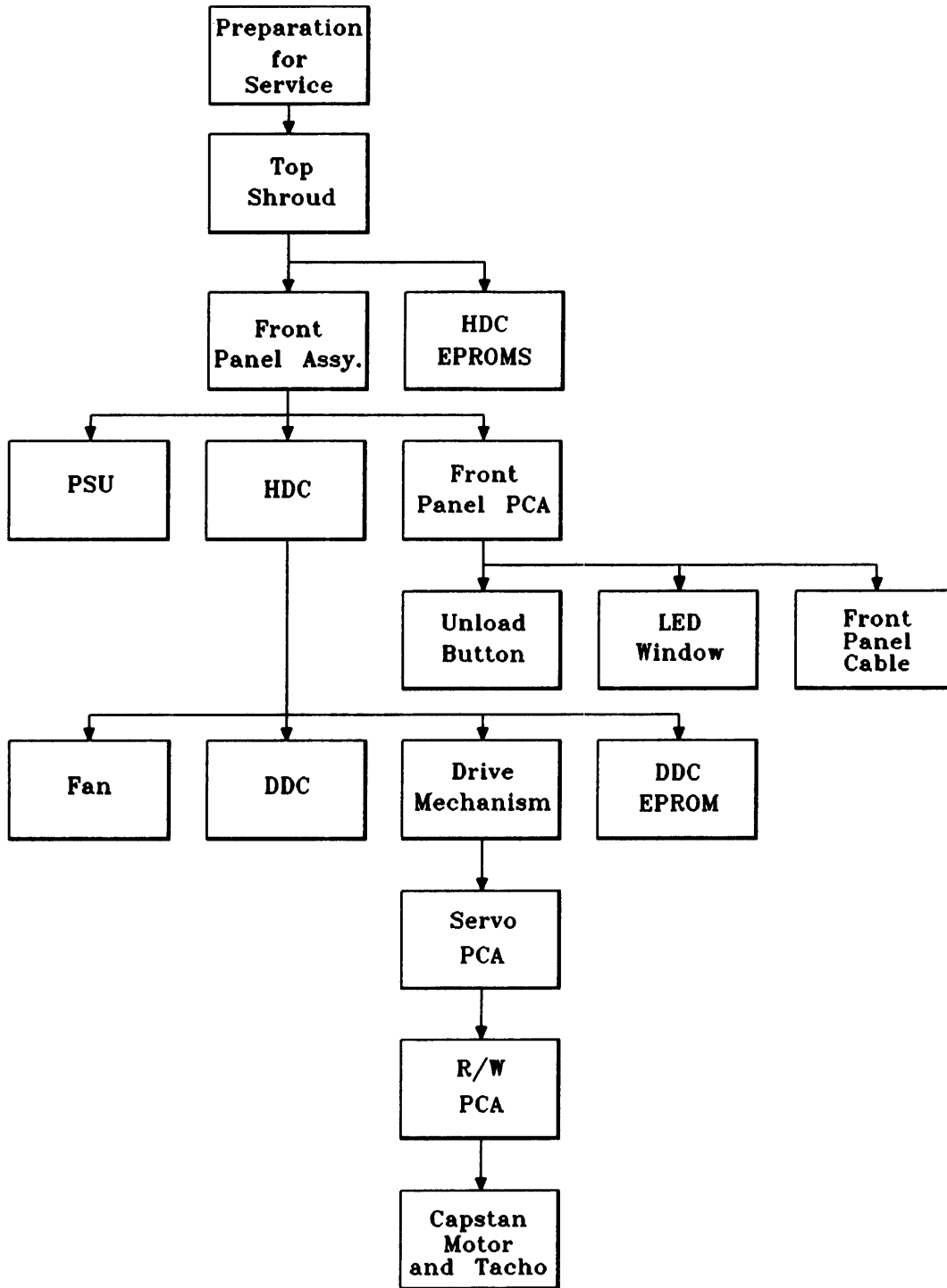

Figure 11-9. Order of Disassembly (5 PCA version)

Table 11-1. Diagnostic/Self-Test Errors (TERRORS) (5 PCA)

NUMBER		CAUSE or Test Description	SUSPECT HARDWARE
DEC	HEX		
00		Complete test of Tape Drive	
01		HDC-DDC interface. Read Servo Status	DDC, HDC
02		DDC Circuitry	
03		a) Microcomputer test	DDC
04		b) Read/Write loopback	DDC
05		HDC-DDC Read/Write loopback.	DDC, HDC
06		HDC-DDC-Servo Interface	Servo, DDC, HDC
07		Servo Circuitry	
08		a) Microcomputer	Servo
09		b) Capstan Motor Drive Circuit	Servo, Capstan Motor
10		c) Tachometer	Servo, Capstan Motor
11		d) Capstan Motor	Capstan Motor, Servo
12		e) Head Stepper Circuit	Servo and Head Stepper
13		<p>Test the read portion of the Read/Write assembly.</p> <p>Start by executing a Put Gaps on Tape command. This will assume unit works and a Key Found signal can be generated. A failure of this command will cause the test to continue through the read tests, trying to diagnose what caused the failure. If the read tests all pass, the testing will halt and this test number will be the failing test.</p>	Read/Write, DDC, Servo

Table 11-1. Diagnostic/Self-Test Errors (TERRORS) (5 PCA) continued

NUMBER		CAUSE or Test Description	SUSPECT HARDWARE
DEC	HEX		
14		With Read Gain set to minimum and Channel 0 positioned on the tape, enable Read with Read Head 0 and check for Overthreshold not being set.	Read/Write, DDC, HDC
15		With Read Gain set to minimum and Channel 0 positioned on the tape, enable Read with Write Head 0 and check for Overthreshold not being set.	Read/Write, DDC, HDC
16		With Read Gain set to a maximum and Channel 0 positioned on the tape, enable Read with Read Head 0 and check for overthreshold being set.	Read/Write, Stepper motor, DDC
17		With Read Gain set to maximum and Channel 0 positioned on the tape, enable Read with Write Head 0 and check for Overthreshold being set.	Read/Write, Servo, DDC
18		With Read Gain set to a minimum and Channel 1 positioned on the tape, enable Read with Read Head 1 and check for Overthreshold not being set.	Read/Write, DDC, HDC
19		With Read Gain set to a minimum and Channel 1 positioned on the tape, enable Read with Write Head 1 and check for Overthreshold not being set.	Read/Write, DDC, HDC
20		With Read Gain set to a maximum and Channel 1 positioned on the tape, enable Read with Read Head 1 and check for Overthreshold being set.	Read/Write, Servo, DDC
21		With Read Gain set to maximum and Channel 1 positioned on the tape, enable Read with Write Head 1 and check for Overthreshold being set.	Read/Write, Servo, DDC
22		Test the write portion of the Read/Write assembly.	Read/Write
23		After the edge of tape has been found and the tape wound to BOT, execute a Locate and Write to track 0, Key 4 with Channel 0. Read back the written data and verify it is the same data that was written. If not, return an error.	Read/Write, DDC, Drive Mechanism
24		Execute a Locate and Write to track 7, Key 5 with Channel 1. Read back the written data and verify it is the same data that was written. If not, return an error.	Read/Write, DDC, Drive Mechanism



Table 11-2. Run-Time Drive Errors (DERRORS) (5 PCA).

NUMBER		CAUSE or Test Description	SUSPECT HARDWARE
DEC	HEX		
177	B1	<p>Recoverable dual errors (one byte)</p> <p>Two frames were bad (CRC error or missing) which were recoverable through XOR circuitry. (Marginal or recoverable)</p>	None
178	B2	<p>Single frame error (one byte)</p> <p>Only one frame with bad CRC or missing. (Marginal or recoverable)</p>	None
179	B3	<p>Unrecoverable data (one byte)</p> <p>Combination of frame CRC errors or missing frames such that data could not be recovered through XOR circuitry. (Marginal, recoverable or unrecoverable)</p>	None
180	B4	<p>DMA handshake error (one byte)</p> <p>Overflow or underflow has occurred between HDC and DDC. (Marginal, recoverable or unrecoverable)</p>	HDC, DDC
181	B5	<p>DMA failure (one byte)</p> <p>Not enough frames detected during read or read-while-write. (Marginal recoverable, or unrecoverable)</p>	HDC, DDC
185	B9	<p>Key error (one byte)</p> <p>One key past target, keys past target, bad key CRC, time-out of key sync, wrong key sent or verify failed. This error occurs during transfer, not seek to target or seek to perform retries. (Marginal, recoverable, unrecoverable, or latency induced)</p>	DDC
186	BA	<p>Seek error (one byte)</p> <p>Seek to target required retries or failed because of time-out or keys past target. (Unit fault)</p>	DDC

Table 11-2. Run-Time Drive Errors (DERRORS) (5 PCA) continued.

NUMBER		CAUSE or Test Description	SUSPECT HARDWARE
DEC	HEX		
187	BB	<p>Seek to a jump spare (one byte)</p> <p>A latency was induced due to seeking to a jump spare during transaction (Latency induced)</p>	DDC
190	BE	<p>Reposition failure (one byte)</p> <p>Reposition of tape to next target address after tape access command required retries or failed. (Unit fault)</p>	DDC
193	C1	<p>Log overflow (two bytes)</p> <p>Log indicated in postbyte overflowed. (Possible loss of entries)</p> <p>0 = Manufacturer's block                      1 = Sparing table                      2 = Error rate test log                      3 = Runtime error log                      4 = Use log                      (Maintenance track overflow)</p>	Tape Drive Subsystem: DDC, R/W Drive Mechanism
194	C2	<p>Unable to read log (two bytes)</p> <p>Log indicated in postbyte could not be read in multiple retries. (For sparing table, this could mean that it was never written or errors preclude it from being written. For other logs, if log was never written this error will not occur. Log will be returned as empty.) Postbyte log codes are defined above. (Unrecoverable data, uninitialized media, unit fault)</p>	Uninitialized cartridge, Tape Drive Subsystem: DDC, R/W Drive Mechanism
195	C3	<p>Unable to write log (two bytes)</p> <p>Log indicated in postbyte could not be written on any track in multiple retries. Postbyte log codes are defined above. (Unrecoverable data)</p>	
196	C4	<p>Log only written on one track (two bytes)</p> <p>Log indicated in postbyte could only be written on one track rather than the usual two. Postbyte log codes are defined above. (Unrecoverable data)</p>	

Table 11-2. Run-Time Drive Errors (DERRORS) (5 PCA) continued.

NUMBER		CAUSE or Test Description	SUSPECT HARDWARE
DEC	HEX		
200	C8	<p>Servo error (two bytes)</p> <p>Command to servo processor was not successfully executed. Postbyte contains status returned by servo processor:</p> <p>00H = Power on state (servo processor is reset)            FFH = Busy/Active            1(T)H = Rewind/T = track            2(T)H = Forward/T = track            3(T)H = Stopped/T = track            40H = Invalid command            41H = Loss of speed control            44H = Cannot find edge of tape            48H = Pre-pos gaps, no keys            50H = Cannot calibrate speed            61H = Unspool likely, no keys found            64H = EOT active            68H = BOT active            (Unit fault)</p>	
206	CE	<p>Load error (two bytes)</p> <p>This cartridge failed the load sequence. Failure is recorded in postbyte:</p> <p>1 = Load diagnostics failed            2 = Seek to EOT failed            3 = Speed calibration failed            4 = Gain set failed            5 = Seek to BOT failed            6 = Edge find failed            (Unit fault)</p>	
207	CF	<p>Unload error (two bytes)</p> <p>This cartridge did not successfully complete the normal unload sequence (logs may not have been updated). Failure is recorded in postbyte:</p> <p>1 = Diagnostic result indicated a hardware failure so normal unload was not attempted.</p> <p>2 = Seek to EOT failed            (Unit fault)</p>	

Table 11-2. Run-Time Drive Errors (DERRORS) (5 PCA) continued.

NUMBER		CAUSE or Test Description	SUSPECT HARDWARE
DEC	HEX		
209	D1	<p>Not certified</p> <p>This cartridge is not certified. (Uninitialized media)</p>	None
210	D2	<p>Certify command failed</p> <p>Attempt to certify a cartridge failed. Possible reasons are:</p> <p>1 Requires &gt;80% of the spares to be used up. 2 Can't write spares table to tape. 3 Error rate test failed due to log overflow or seek failure. 4 Transfer canceled 5 Certify specified with 0 loops.</p> <p>(Uninitialized media)</p>	
216	D8	<p>Hardware fail (one byte)</p> <p>Attempt to access the tape (with a non-diagnostic command) when previous diagnostic command, power-on or load diagnostics indicated a hardware failure. (Unit fault)</p>	
217	D9	<p>Write circuit failure (one byte)</p> <p>Attempt to perform a write command when write circuitry has failed power-on or load diagnostics or has failed a diagnostic command. (Unit fault)</p>	
223	DF	<p>No buffers in system (one byte)</p> <p>No buffers are available to complete transaction. (Controller fault)</p>	

## 11-2. 4 PCA VERSION

The four PCA version first appeared in tape drives beginning at serial number 2440A00779 (see Service Note 9144A-1). This included a single DDC PCA which replaced the dual board DDC. By using VLSI technology the new PCA was the same size as one of the two PCAs it replaced. This single board DDC obsoleted the dual board DDC. The DDC remained functionally the same.

The replaceable parts which differ from the present version include:

07940 - 60195 HDC PCA  
09144 - 66512 DDC PCA  
09144 - 66513 R/W PCA  
09144 - 66517 S PCA  
09144 - 60094 PSU PCA

09144 - 04401 Chassis  
09144 - 61601 Cable DDC - R/W - S  
09144 - 61602 Cable Power  
09144 - 61605 Cable DDC - Front Panel PCA  
09144 - 61606 Cable HDC - DDC

The layout of the major electronic assemblies is shown in figure 11-10. Figures 11-11 to 11-14 show the PCAs. Figures 11-15 to 11-17 show the interconnections between the PCAs.

Figure 11-18 shows the order of disassembly. When using this chart refer to section 6 for appropriate safety warnings and cautions.

Table 11-3 shows the Diagnostic/Self-Test Errors (which are displayed as a result of performing self-tests) and their interpretation. Table 11-4 shows the Run-Time Drive Errors (which may occur at any time, as the result of a fault) and their interpretation.

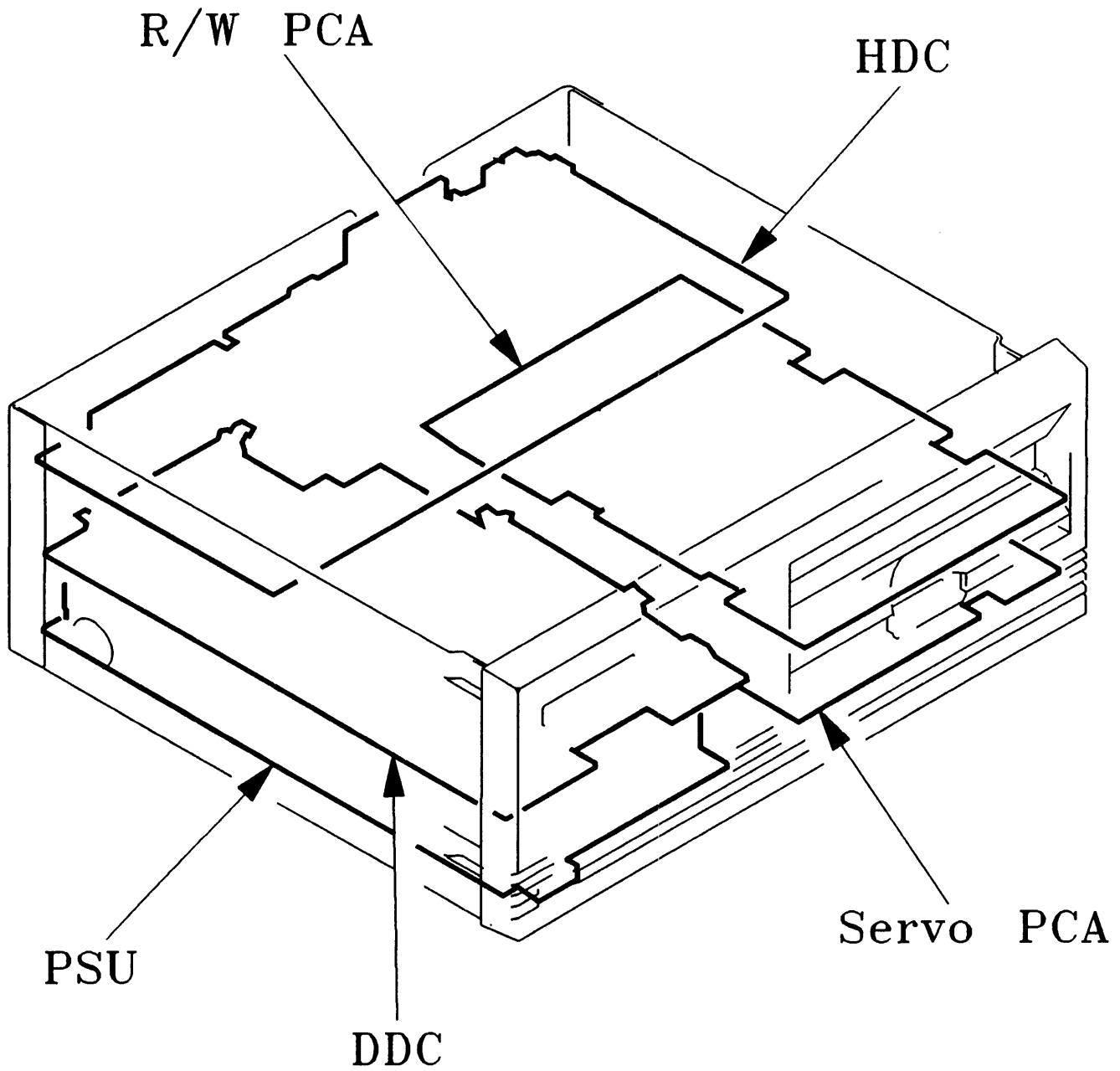

Figure 11-10. Location of PCAs (4 PCA version)

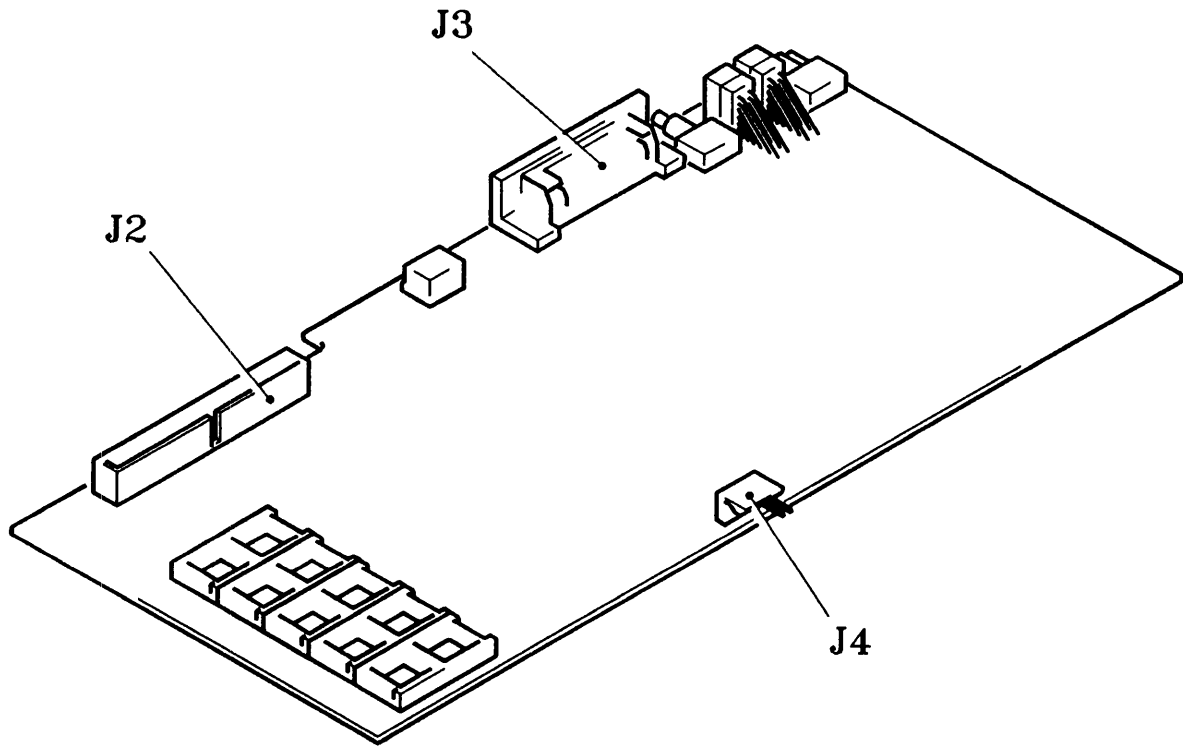

Figure 11-11. The HDC PCA (4 PCA version)

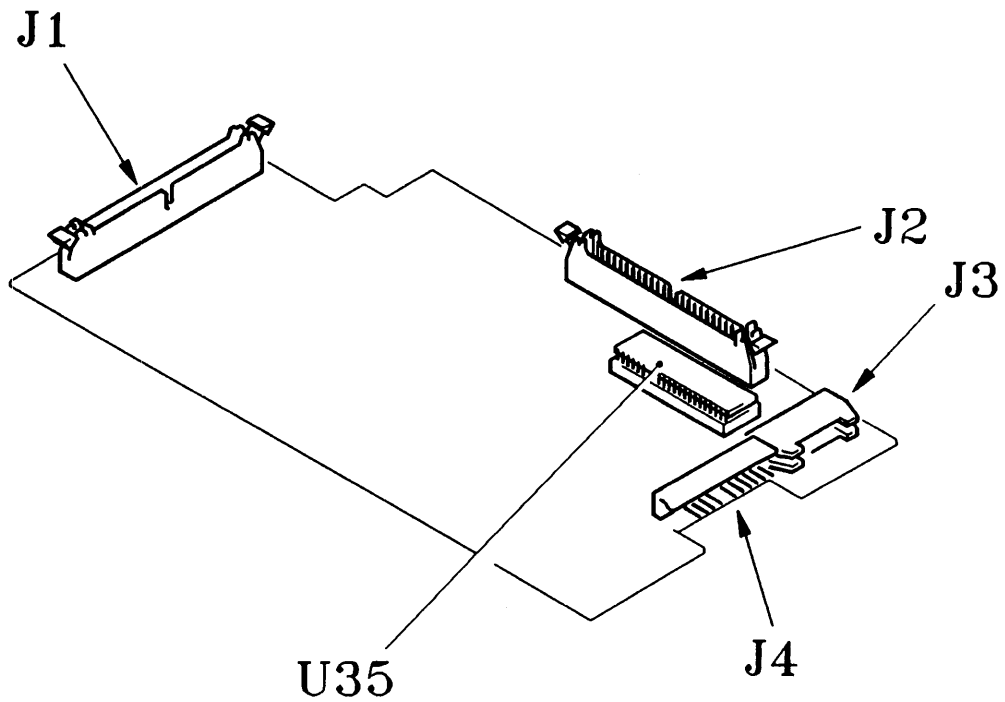

Figure 11-12. The DDC PCA (4 PCA version)

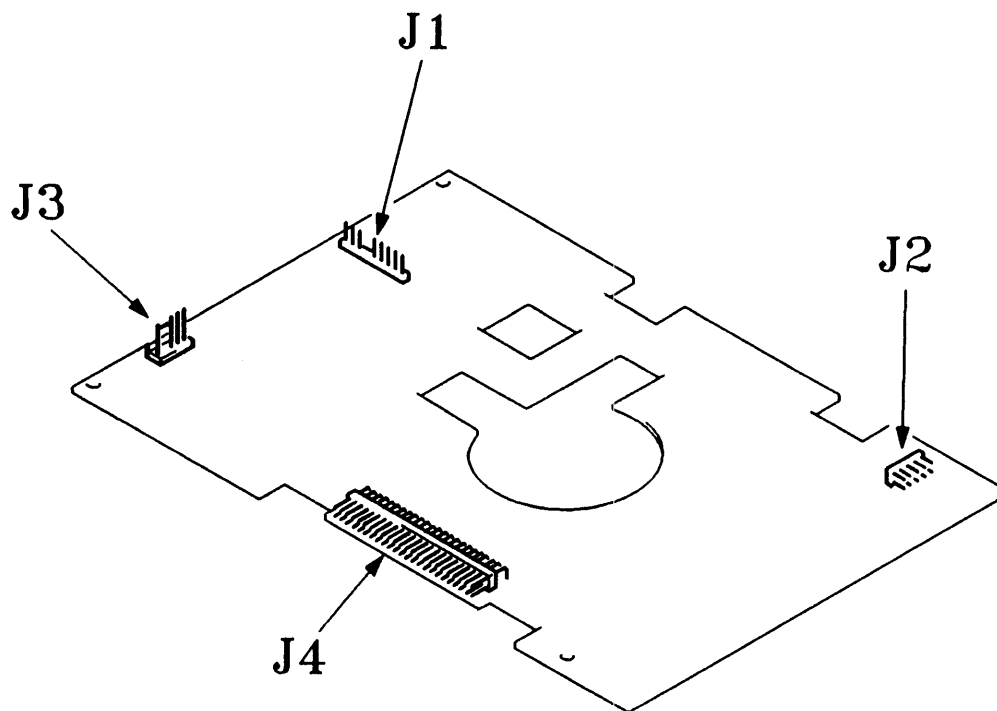

Figure 11-13. The R/W PCA (4 PCA version)

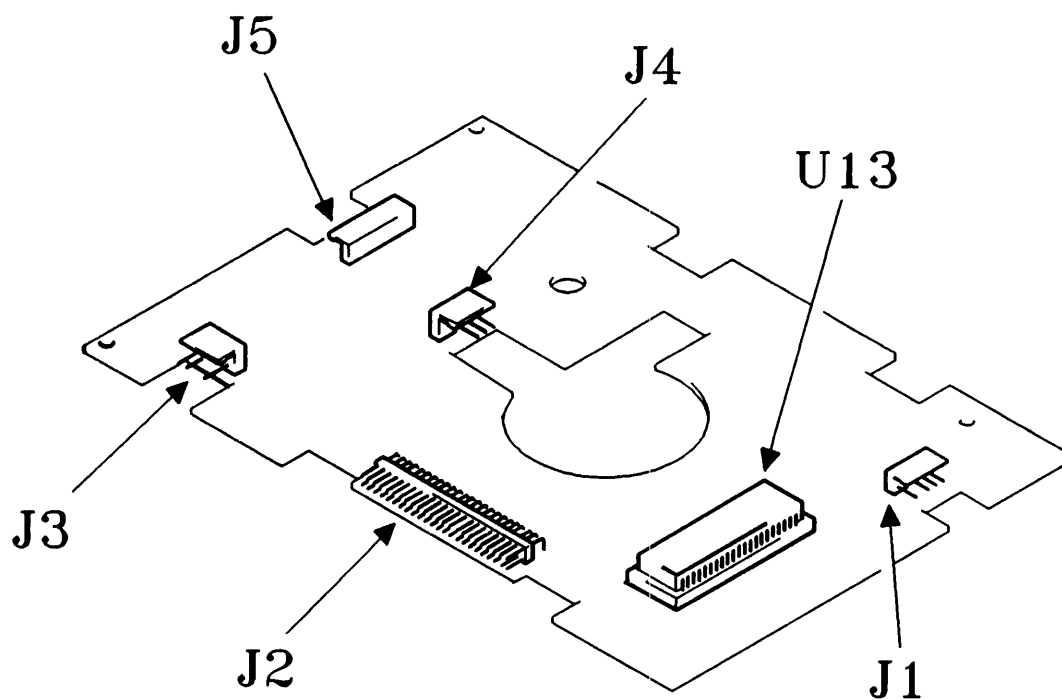

Figure 11-14. The Servo PCA (4 PCA version)



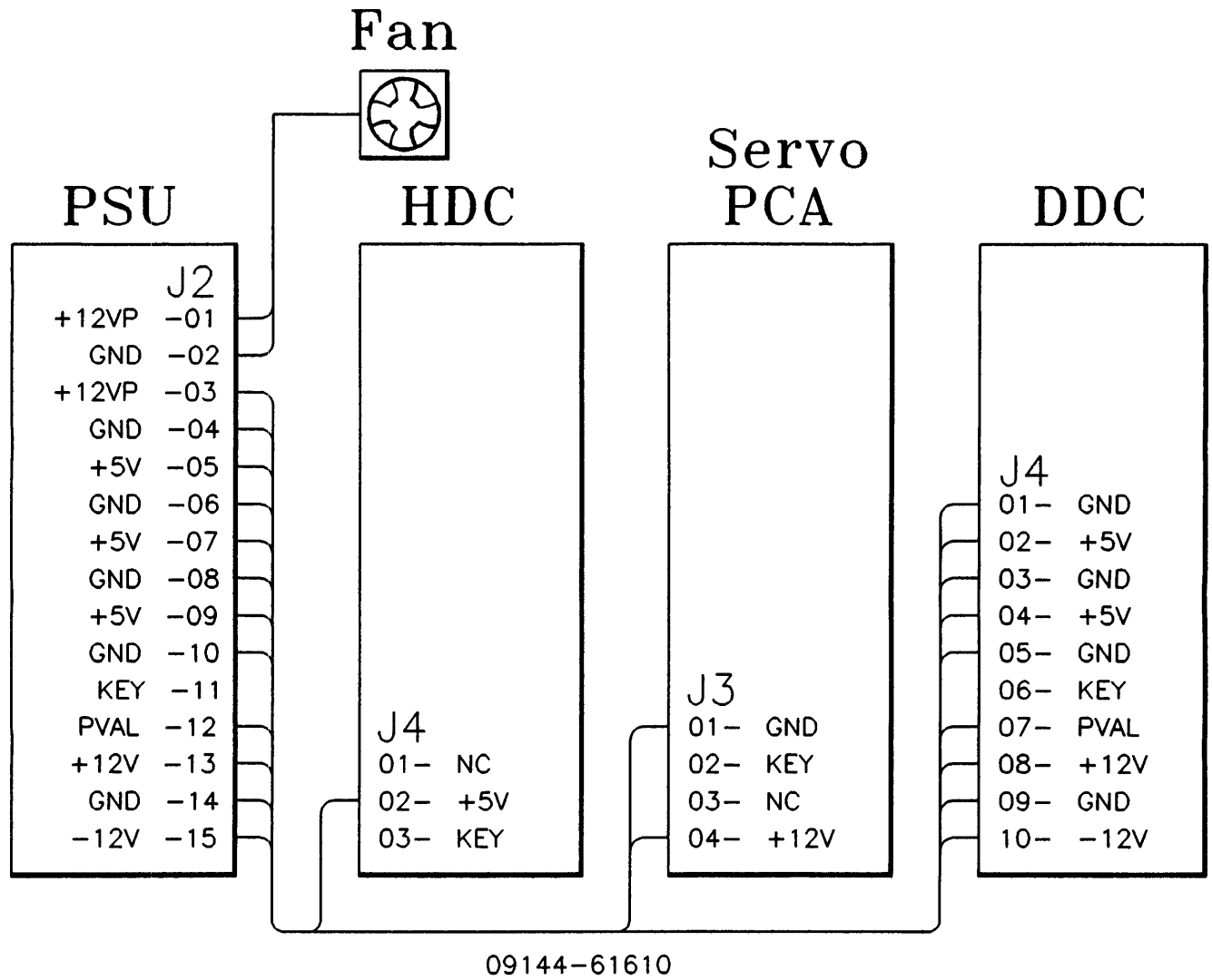

Figure 11-15. Power Cabling (4 PCA version)

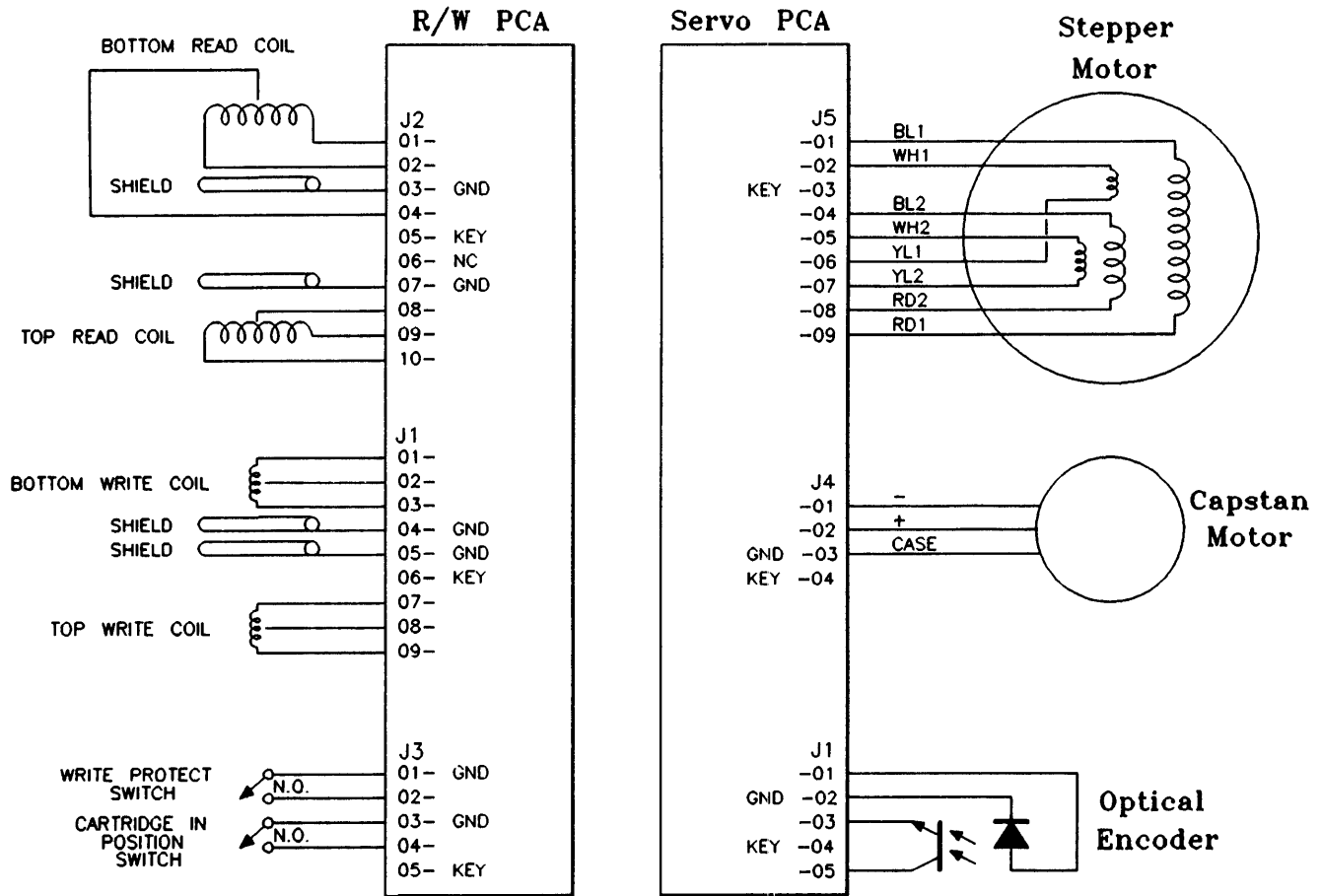

Figure 11-16. Drive Mechanism cabling (4 PCA version)

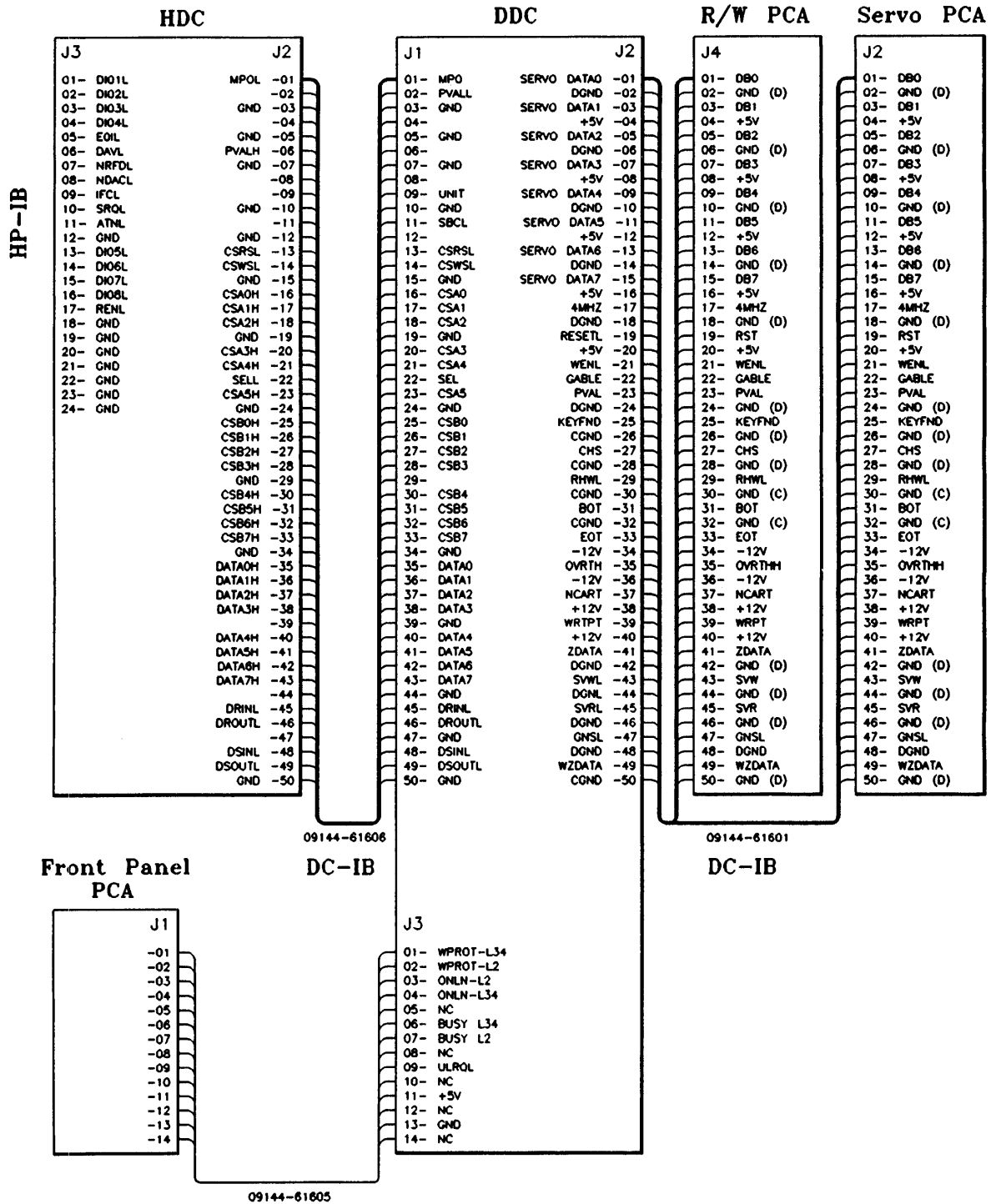

Figure 11-17. Signal Cabling (4 PCA version)

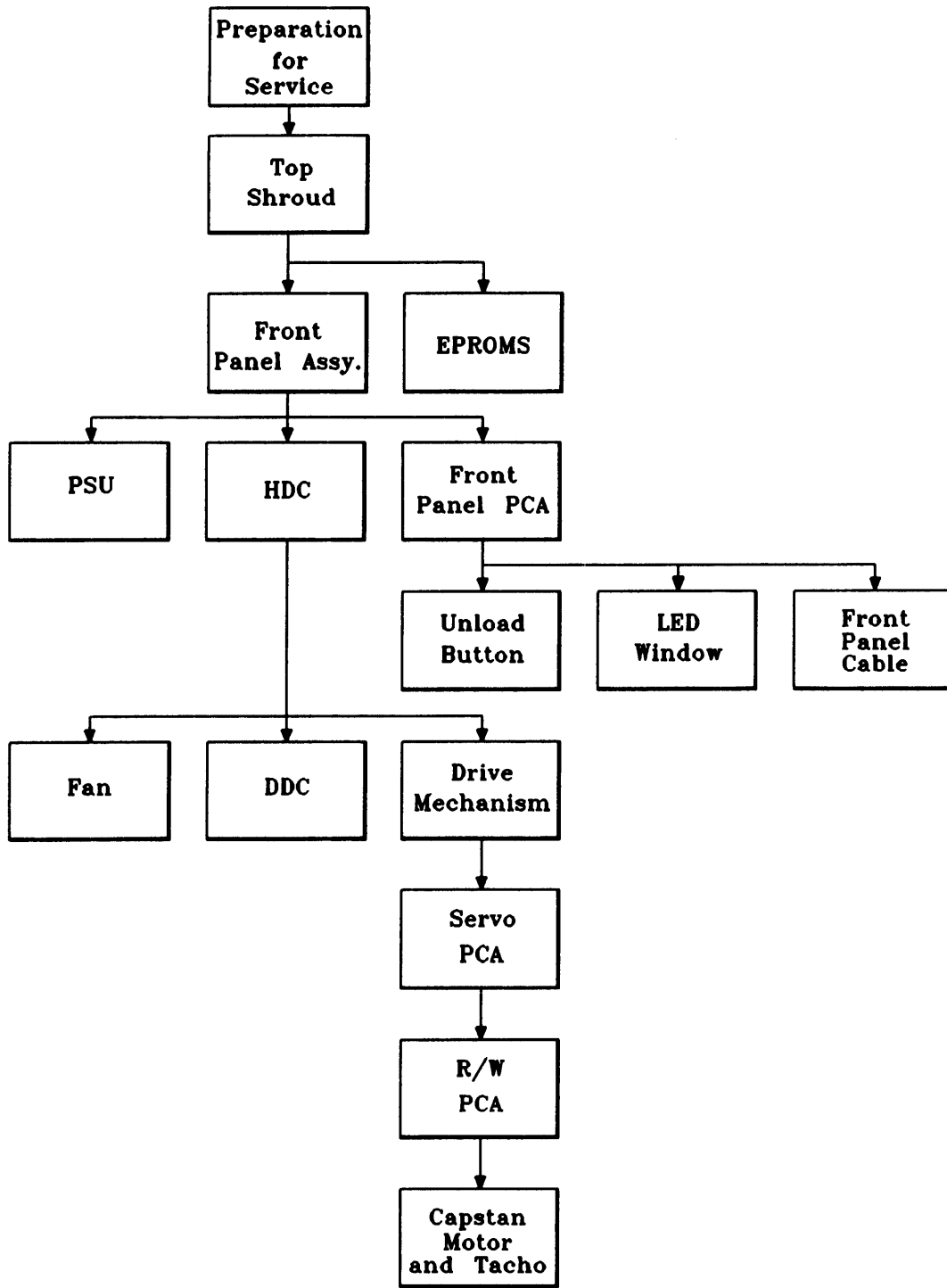

Figure 11-18. Order of Disassembly (4 PCA version)

Table 11-3. Diagnostic/Self-Test Errors (TERRORS) (4 PCA)

NUMBER		CAUSE or Test Description	SUSPECT HARDWARE
DEC	HEX		
00		Complete test of Tape Drive	
01		HDC-DDC interface. Read Servo Status	DDC, HDC
02		DDC Circuitry	
03		a) Microcomputer test	DDC
04		b) Read/Write loopback	DDC
05		HDC-DDC Read/Write loopback.	DDC, HDC
06		HDC-DDC-Servo Interface	Servo, DDC, HDC
07		Servo Circuitry	
08		a) Microcomputer	Servo
09		b) Capstan Motor Drive Circuit	Servo, Capstan Motor
10		c) Tachometer	Servo, Capstan Motor
11		d) Capstan Motor	Capstan Motor, Servo
12		e) Head Stepper Circuit	Servo and Head Stepper
13		<p>Test the read portion of the Read/Write assembly.</p> <p>Start by executing a Put Gaps on Tape command. This will assume unit works and a Key Found signal can be generated. A failure of this command will cause the test to continue through the read tests, trying to diagnose what caused the failure. If the read tests all pass, the testing will halt and this test number will be the failing test.</p>	Read/Write, DDC, Servo

Table 11-3. Diagnostic/Self-Test Errors (TERRORS) (4 PCA) continued

NUMBER		CAUSE or Test Description	SUSPECT HARDWARE
DEC	HEX		
14		With Read Gain set to minimum and Channel 0 positioned on the tape, enable Read with Read Head 0 and check for Overthreshold not being set.	Read/Write, DDC, HDC
15		With Read Gain set to minimum and Channel 0 positioned on the tape, enable Read with Write Head 0 and check for Overthreshold not being set.	Read/Write, DDC, HDC
16		With Read Gain set to a maximum and Channel 0 positioned on the tape, enable Read with Read Head 0 and check for overthreshold being set.	Read/Write, Stepper motor, DDC
17		With Read Gain set to maximum and Channel 0 positioned on the tape, enable Read with Write Head 0 and check for Overthreshold being set.	Read/Write, Servo, DDC
18		With Read Gain set to a minimum and Channel 1 positioned on the tape, enable Read with Read Head 1 and check for Overthreshold not being set.	Read/Write, DDC, HDC
19		With Read Gain set to a minimum and Channel 1 positioned on the tape, enable Read with Write Head 1 and check for Overthreshold not being set.	Read/Write, DDC, HDC
20		With Read Gain set to a maximum and Channel 1 positioned on the tape, enable Read with Read Head 1 and check for Overthreshold being set.	Read/Write, Servo, DDC
21		With Read Gain set to maximum and Channel 1 positioned on the tape, enable Read with Write Head 1 and check for Overthreshold being set.	Read/Write, Servo, DDC
22		Test the write portion of the Read/Write assembly.	Read/Write
23		After the edge of tape has been found and the tape wound to BOT, execute a Locate and Write to track 0, Key 4 with Channel 0. Read back the written data and verify it is the same data that was written. If not, return an error.	Read/Write, DDC, Drive Mechanism
24		Execute a Locate and Write to track 7, Key 5 with Channel 1. Read back the written data and verify it is the same data that was written. If not, return an error.	Read/Write, DDC, Drive Mechanism

Table 11-4. Run-Time Drive Errors (DERRORS) (4 PCA).

NUMBER		CAUSE or Test Description	SUSPECT HARDWARE
DEC	HEX		
177	B1	<p>Recoverable dual errors (one byte)</p> <p>Two frames were bad (CRC error or missing) which were recoverable through XOR circuitry. (Marginal or recoverable)</p>	None
178	B2	<p>Single frame error (one byte)</p> <p>Only one frame with bad CRC or missing. (Marginal or recoverable)</p>	None
179	B3	<p>Unrecoverable data (one byte)</p> <p>Combination of frame CRC errors or missing frames such that data could not be recovered through XOR circuitry. (Marginal, recoverable or unrecoverable)</p>	None
180	B4	<p>DMA handshake error (one byte)</p> <p>Overflow or underflow has occurred between HDC and DDC. (Marginal, recoverable or unrecoverable)</p>	HDC, DDC
181	B5	<p>DMA failure (one byte)</p> <p>Not enough frames detected during read or read-while-write. (Marginal recoverable, or unrecoverable)</p>	HDC, DDC
185	B9	<p>Key error (one byte)</p> <p>One key past target, keys past target, bad key CRC, time-out of key sync, wrong key sent or verify failed. This error occurs during transfer, not seek to target or seek to perform retries. (Marginal, recoverable, unrecoverable, or latency induced)</p>	DDC
186	BA	<p>Seek error (one byte)</p> <p>Seek to target required retries or failed because of time-out or keys past target. (Unit fault)</p>	DDC

Table 11-4. Run-Time Drive Errors (DERRORS) (4 PCA) continued.

NUMBER		CAUSE or Test Description	SUSPECT HARDWARE
DEC	HEX		
187	BB	Seek to a jump spare (one byte)  A latency was induced due to seeking to a jump spare during transaction (Latency induced)	DDC
190	BE	Reposition failure (one byte)  Reposition of tape to next target address after tape access command required retries or failed. (Unit fault)	DDC
193	C1	Log overflow (two bytes)  Log indicated in postbyte overflowed. (Possible loss of entries)  0 = Manufacturer's block 1 = Sparing table 2 = Error rate test log 3 = Runtime error log 4 = Use log (Maintenance track overflow)	Tape Drive Subsystem: DDC, R/W Drive Mechanism
194	C2	Unable to read log (two bytes)  Log indicated in postbyte could not be read in multiple retries. (For sparing table, this could mean that it was never written or errors preclude it from being written. For other logs, if log was never written this error will not occur. Log will be returned as empty.) Postbyte log codes are defined above. (Unrecoverable data, uninitialized media, unit fault)	Uninitialized cartridge, Tape Drive Subsystem: DDC, R/W Drive Mechanism
195	C3	Unable to write log (two bytes)  Log indicated in postbyte could not be written on any track in multiple retries. Postbyte log codes are defined above. (Unrecoverable data)	
196	C4	Log only written on one track (two bytes)  Log indicated in postbyte could only be written on one track rather than the usual two. Postbyte log codes are defined above. (Unrecoverable data)	



Table 11-4. Run-Time Drive Errors (DERRORS) (4 PCA) continued.

NUMBER		CAUSE or Test Description	SUSPECT HARDWARE
DEC	HEX		
200	C8	<p>Servo error (two bytes)</p> <p>Command to servo processor was not successfully executed. Postbyte contains status returned by servo processor:</p> <p>00H = Power on state (servo processor is reset)            FFH = Busy/Active            1(T)H = Rewind/T = track            2(T)H = Forward/T = track            3(T)H = Stopped/T = track            40H = Invalid command            41H = Loss of speed control            44H = Cannot find edge of tape            48H = Pre-pos gaps, no keys            50H = Cannot calibrate speed            61H = Unspool likely, no keys found            64H = EOT active            68H = BOT active            (Unit fault)</p>	
206	CE	<p>Load error (two bytes)</p> <p>This cartridge failed the load sequence. Failure is recorded in postbyte:</p> <p>1 = Load diagnostics failed            2 = Seek to EOT failed            3 = Speed calibration failed            4 = Gain set failed            5 = Seek to BOT failed            6 = Edge find failed            (Unit fault)</p>	
207	CF	<p>Unload error (two bytes)</p> <p>This cartridge did not successfully complete the normal unload sequence (logs may not have been updated). Failure is recorded in postbyte:</p> <p>1 = Diagnostic result indicated a hardware failure so normal unload was not attempted.</p> <p>2 = Seek to EOT failed            (Unit fault)</p>	

Table 11-4. Run-Time Drive Errors (DERRORS) (4 PCA) continued.

NUMBER		CAUSE or Test Description	SUSPECT HARDWARE
DEC	HEX		
209	D1	<p>Not certified</p> <p>This cartridge is not certified. (Uninitialized media)</p>	None
210	D2	<p>Certify command failed</p> <p>Attempt to certify a cartridge failed. Possible reasons are:</p> <p>1 Requires &gt;80% of the spares to be used up. 2 Can't write spares table to tape. 3 Error rate test failed due to log overflow or seek failure. 4 Transfer canceled 5 Certify specified with 0 loops.</p> <p>(Uninitialized media)</p>	
216	D8	<p>Hardware fail (one byte)</p> <p>Attempt to access the tape (with a non-diagnostic command) when previous diagnostic command, power-on or load diagnostics indicated a hardware failure. (Unit fault)</p>	
217	D9	<p>Write circuit failure (one byte)</p> <p>Attempt to perform a write command when write circuitry has failed power-on or load diagnostics or has failed a diagnostic command. (Unit fault)</p>	
223	DF	<p>No buffers in system (one byte)</p> <p>No buffers are available to complete transaction. (Controller fault)</p>	

### 11-3. 3 PCA VERSION

In the three PCA version of the HP 9144A Tape Drive the HDC and DDC PCAs have been combined to produce a single board controller. This version appeared in tape drives beginning at serial number 2444A01281 (see Service Note 9144A-4). The new PCA was functionally the same, occupied less space and was more reliable than the two PCAs it replaced. This new PCA did not render the DDC and HDC PCAs obsolete. These continued to be manufactured for use in other products.

This was the first type of HP 9144A to be manufactured in Bristol (UK), having been transferred from Greeley (USA).

During the production run of the three PCA version, the power supply PCA was replaced by one of improved performance and reliability (see Service Note 9144A-10). The introduction began at serial number 2519A03764.

The replaceable parts which differ from the present version include:

09144 - 66515 SBCONT PCA  
09144 - 66513 R/W PCA  
09144 - 66517 S PCA  
09133 - 67120 PSU PCA (same as present version)  
09144 - 04401 Chassis  
09144 - 61611 Cable SBCONT - R/W - S  
09144 - 61610 Cable Power  
09144 - 61612 Cable SBCONT - Front Panel PCA

The layout of the major electronic assemblies is shown in figure 11-19. Figures 11-20 to 11-22 show the PCAs. Figures 11-23 to 11-25 show the interconnections between the PCAs.

Figure 11-26 shows the order of disassembly. When using this chart refer to section 6 for appropriate safety warnings and cautions.

Table 11-5 shows the Diagnostic/Self-Test Errors (which are displayed as a result of performing self-tests) and their interpretation. Table 11-6 shows the Run-Time Drive Errors (which may occur at any time, as the result of a fault) and their interpretation.

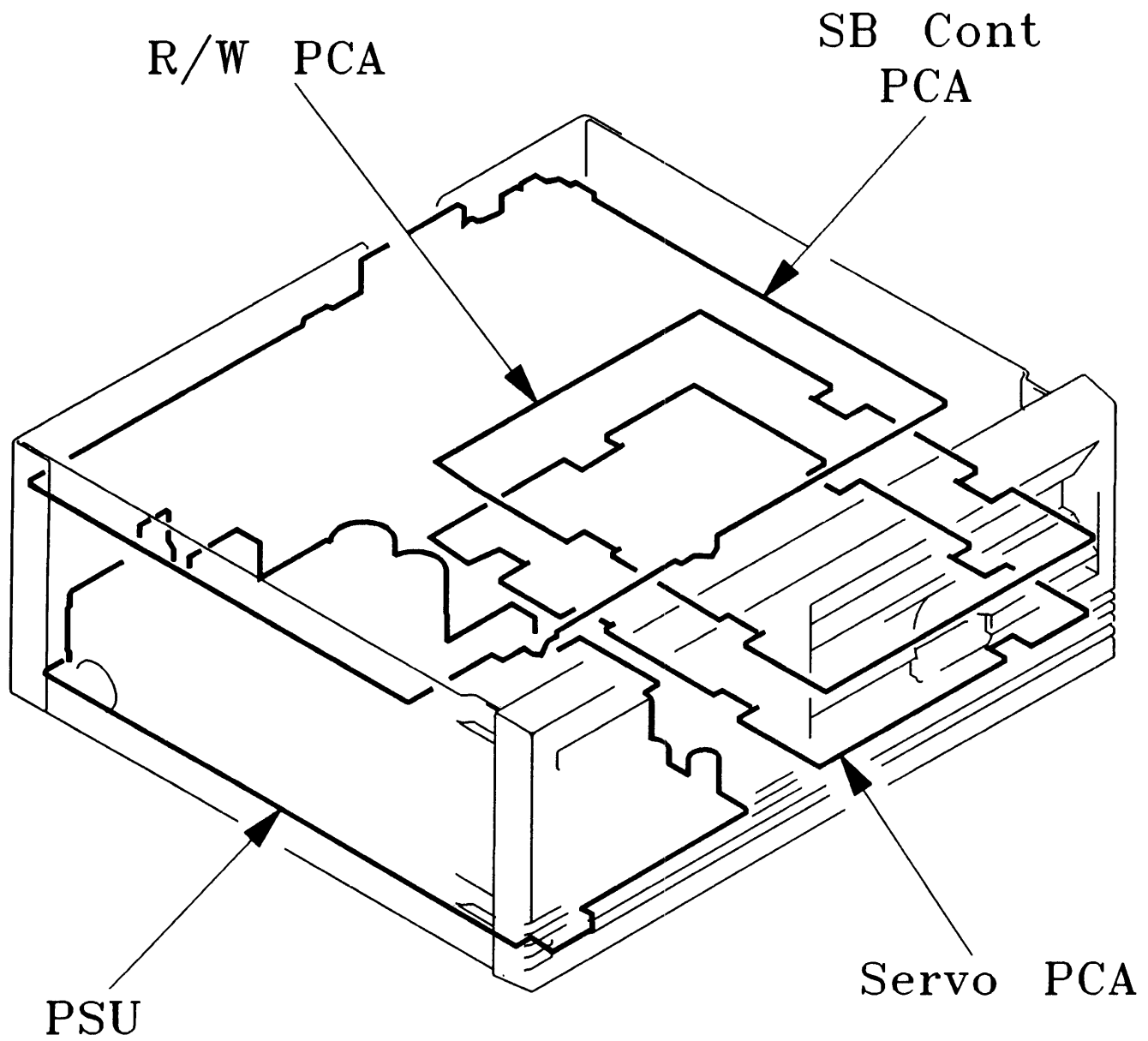

Figure 11-19. Location of PCAs (3 PCA version)

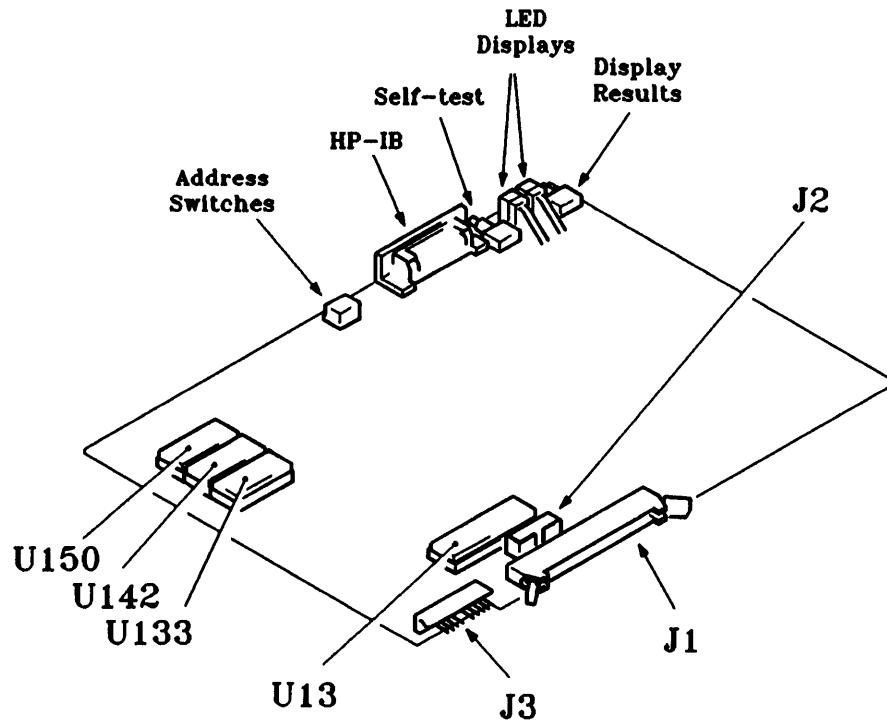

Figure 11-20. The SBCONT PCA (3 PCA version)

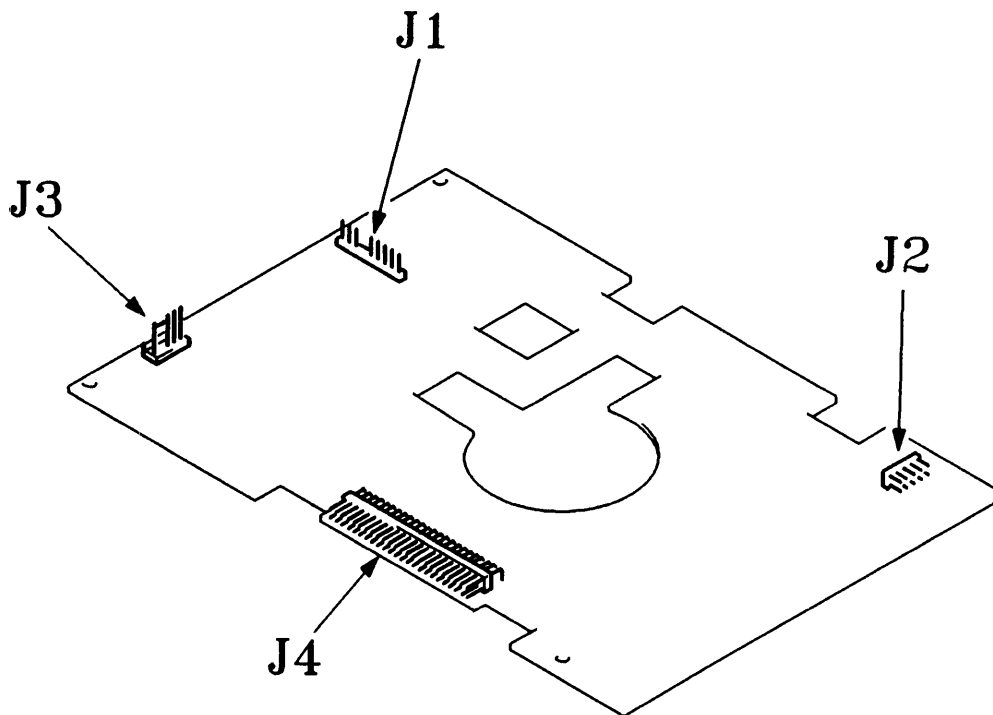

Figure 11-21. The R/W PCA (3 PCA version)

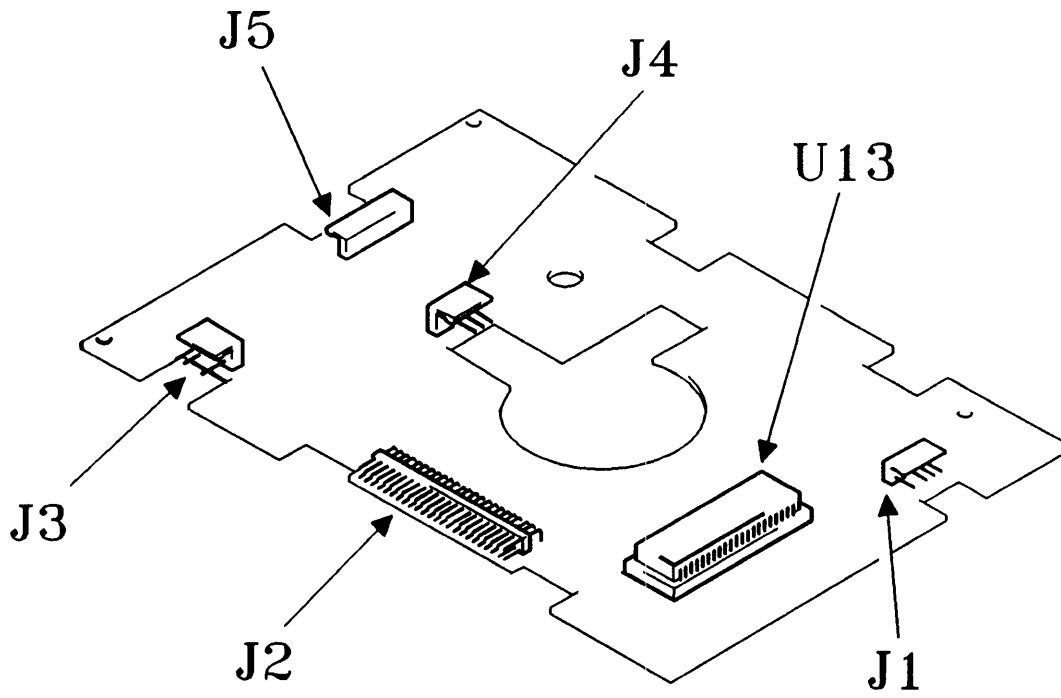

Figure 11-22. The Servo PCA (3 PCA version)

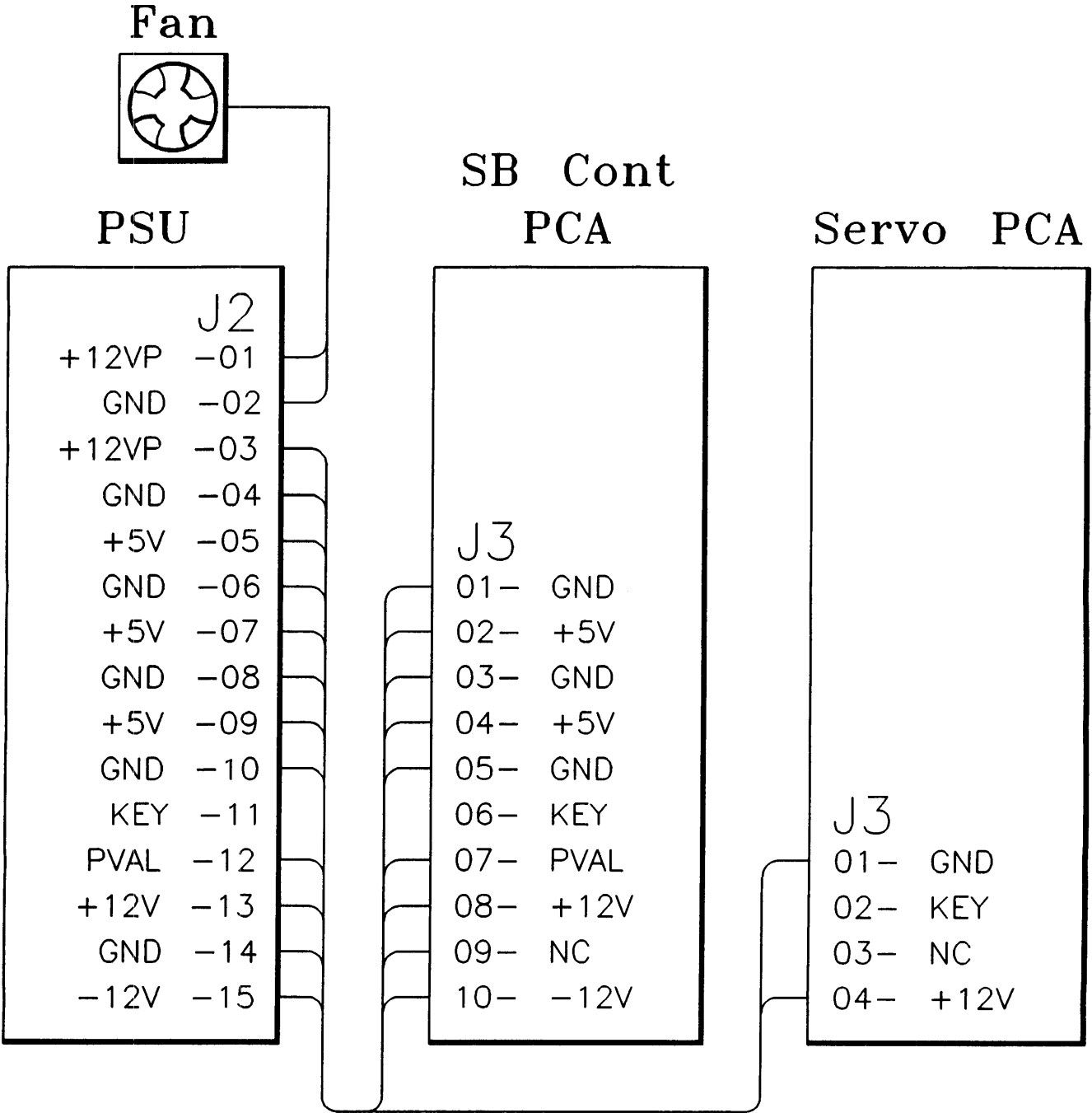

Figure 11-23. Power Cabling (3 PCA version)

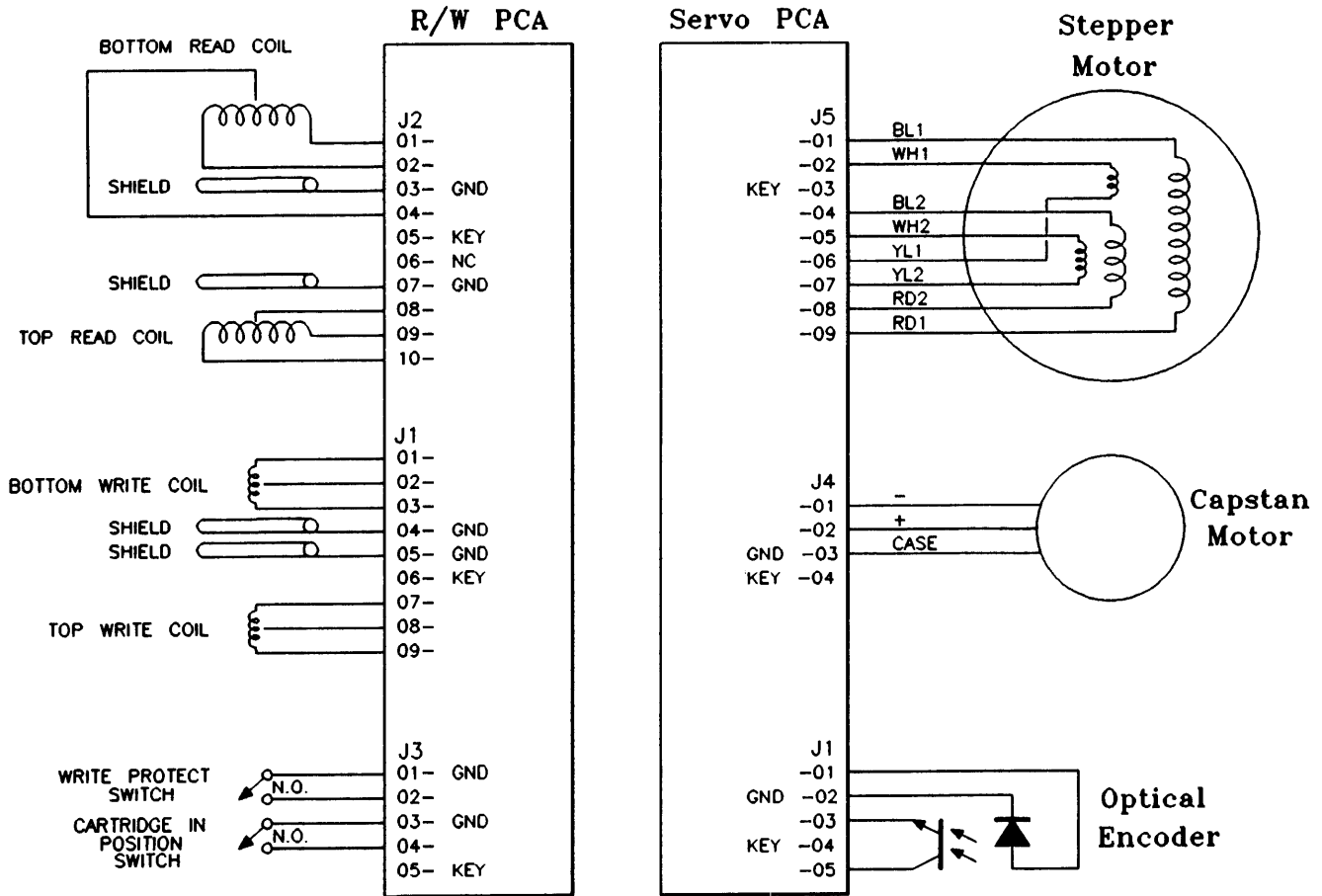

Figure 11-24. Drive Mechanism cabling (3 PCA version)



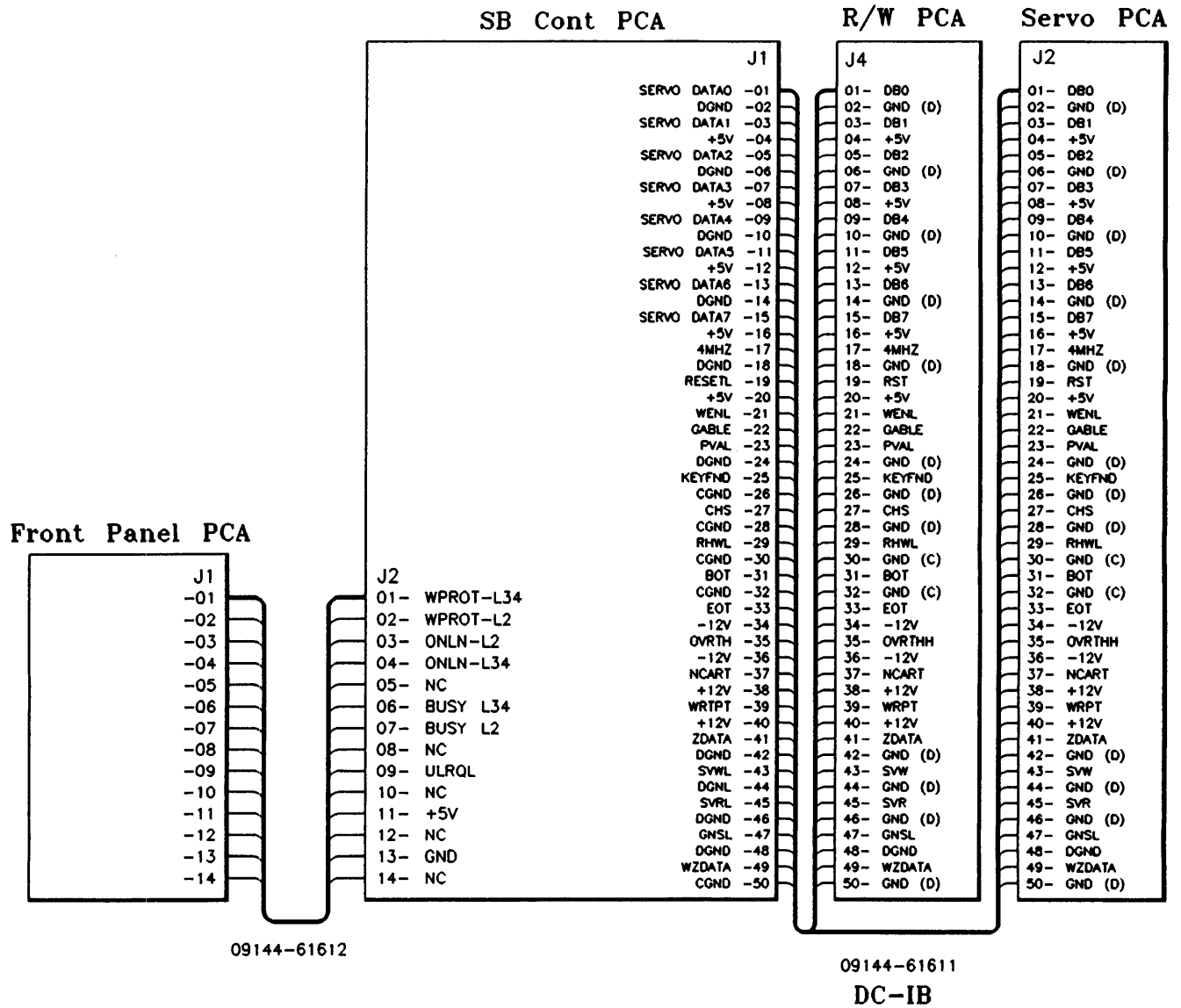

Figure 11-25. Signal Cabling (3 PCA version)

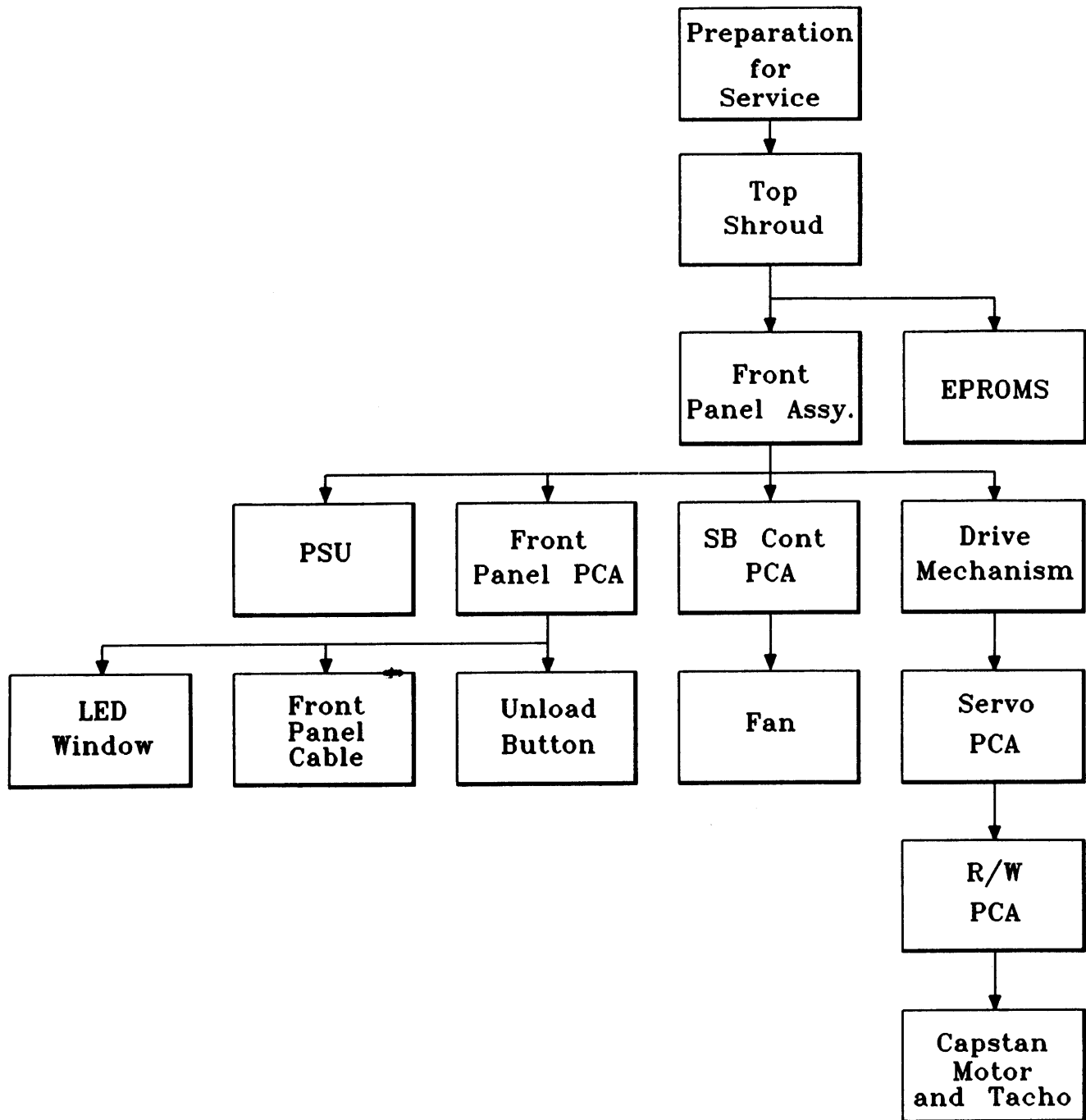

Figure 11-26. Order of Disassembly (3 PCA version)

Table 11-5. Diagnostic/Self-Test Errors (TERRORS) (3 PCA)

NUMBER		CAUSE or Test Description	SUSPECT HARDWARE
DEC	HEX		
00		Complete test of Tape Drive	
01		HDC-DDC interface. Read Servo Status	SBCONT
02		SBCONT Circuitry	
03		a) Microcomputer test	SBCONT
04		b) Read/Write loopback	SBCONT
05		HDC-DDC Read/Write loopback.	SBCONT
06		HDC-DDC-Servo Interface	Servo, SBCONT
07		Servo Circuitry	
08		a) Microcomputer	Servo
09		b) Capstan Motor Drive Circuit	Servo, Capstan Motor
10		c) Tachometer	Servo, Capstan Motor
11		d) Capstan Motor	Capstan Motor, Servo
12		e) Head Stepper Circuit	Servo and Head Stepper
13		<p>Test the read portion of the Read/Write assembly.</p> <p>Start by executing a Put Gaps on Tape command. This will assume unit works and a Key Found signal can be generated. A failure of this command will cause the test to continue through the read tests, trying to diagnose what caused the failure. If the read tests all pass, the testing will halt and this test number will be the failing test.</p>	Read/Write, SBCONT, Servo

Table 11-5. Diagnostic/Self-Test Errors (TERRORS) (3 PCA) continued

NUMBER		CAUSE or Test Description	SUSPECT HARDWARE
DEC	HEX		
14		With Read Gain set to minimum and Channel 0 positioned on the tape, enable Read with Read Head 0 and check for Overthreshold not being set.	Read/Write, SBCONT
15		With Read Gain set to minimum and Channel 0 positioned on the tape, enable Read with Write Head 0 and check for Overthreshold not being set.	Read/Write, SBCONT
16		With Read Gain set to a maximum and Channel 0 positioned on the tape, enable Read with Read Head 0 and check for overthreshold being set.	Read/Write, Stepper motor, SBCONT
17		With Read Gain set to maximum and Channel 0 positioned on the tape, enable Read with Write Head 0 and check for Overthreshold being set.	Read/Write, Servo, SBCONT
18		With Read Gain set to a minimum and Channel 1 positioned on the tape, enable Read with Read Head 1 and check for Overthreshold not being set.	Read/Write, SBCONT
19		With Read Gain set to a minimum and Channel 1 positioned on the tape, enable Read with Write Head 1 and check for Overthreshold not being set.	Read/Write, SBCONT
20		With Read Gain set to a maximum and Channel 1 positioned on the tape, enable Read with Read Head 1 and check for Overthreshold being set.	Read/Write, Servo, SBCONT
21		With Read Gain set to maximum and Channel 1 positioned on the tape, enable Read with Write Head 1 and check for Overthreshold being set.	Read/Write, Servo, SBCONT
22		Test the write portion of the Read/Write assembly.	Read/Write
23		After the edge of tape has been found and the tape wound to BOT, execute a Locate and Write to track 0, Key 4 with Channel 0. Read back the written data and verify it is the same data that was written. If not, return an error.	Read/Write, SBCONT, Drive Mechanism
24		Execute a Locate and Write to track 7, Key 5 with Channel 1. Read back the written data and verify it is the same data that was written. If not, return an error.	Read/Write, SBCONT, Drive Mechanism

Table 11-6. Run-Time Drive Errors (DERRORS) (3 PCA).

NUMBER		CAUSE or Test Description	SUSPECT HARDWARE
DEC	HEX		
177	B1	<p>Recoverable dual errors (one byte)</p> <p>Two frames were bad (CRC error or missing) which were recoverable through XOR circuitry. (Marginal or recoverable)</p>	None
178	B2	<p>Single frame error (one byte)</p> <p>Only one frame with bad CRC or missing. (Marginal or recoverable)</p>	None
179	B3	<p>Unrecoverable data (one byte)</p> <p>Combination of frame CRC errors or missing frames such that data could not be recovered through XOR circuitry. (Marginal, recoverable or unrecoverable)</p>	None
180	B4	<p>DMA handshake error (one byte)</p> <p>Overflow or underflow has occurred between HDC and DDC. (Marginal, recoverable or unrecoverable)</p>	SBCONT
181	B5	<p>DMA failure (one byte)</p> <p>Not enough frames detected during read or read-while-write. (Marginal recoverable, or unrecoverable)</p>	SBCONT
185	B9	<p>Key error (one byte)</p> <p>One key past target, keys past target, bad key CRC, time-out of key sync, wrong key sent or verify failed. This error occurs during transfer, not seek to target or seek to perform retries. (Marginal, recoverable, unrecoverable, or latency induced)</p>	SBCONT
186	BA	<p>Seek error (one byte)</p> <p>Seek to target required retries or failed because of time-out or keys past target. (Unit fault)</p>	SBCONT

Table 11-6. Run-Time Drive Errors (DERRORS) (3 PCA) continued.

NUMBER		CAUSE or Test Description	SUSPECT HARDWARE
DEC	HEX		
187	BB	<p>Seek to a jump spare (one byte)</p> <p>A latency was induced due to seeking to a jump spare during transaction (Latency induced)</p>	SBCONT
190	BE	<p>Reposition failure (one byte)</p> <p>Reposition of tape to next target address after tape access command required retries or failed. (Unit fault)</p>	SBCONT
193	C1	<p>Log overflow (two bytes)</p> <p>Log indicated in postbyte overflowed. (Possible loss of entries)</p> <p>0 = Manufacturer's block 1 = Sparring table 2 = Error rate test log 3 = Runtime error log 4 = Use log (Maintenance track overflow)</p>	Tape Drive Subsystem: SBCONT, R/W Drive Mechanism
194	C2	<p>Unable to read log (two bytes)</p> <p>Log indicated in postbyte could not be read in multiple retries. (For sparing table, this could mean that it was never written or errors preclude it from being written. For other logs, if log was never written this error will not occur. Log will be returned as empty.) Postbyte log codes are defined above. (Unrecoverable data, uninitialized media, unit fault)</p>	Uninitialized cartridge, Tape Drive Subsystem: SBCONT, R/W Drive Mechanism
195	C3	<p>Unable to write log (two bytes)</p> <p>Log indicated in postbyte could not be written on any track in multiple retries. Postbyte log codes are defined above. (Unrecoverable data)</p>	
196	C4	<p>Log only written on one track (two bytes)</p> <p>Log indicated in postbyte could only be written on one track rather than the usual two. Postbyte log codes are defined above. (Unrecoverable data)</p>	

Table 11-6. Run-Time Drive Errors (DERRORS) (3 PCA) continued.

NUMBER		CAUSE or Test Description	SUSPECT HARDWARE
DEC	HEX		
200	C8	<p>Servo error (two bytes)</p> <p>Command to servo processor was not successfully executed. Postbyte contains status returned by servo processor:</p> <p>00H = Power on state (servo processor is reset)            FFH = Busy/Active            1(T)H = Rewind/T = track            2(T)H = Forward/T = track            3(T)H = Stopped/T = track            40H = Invalid command            41H = Loss of speed control            44H = Cannot find edge of tape            48H = Pre-pos gaps, no keys            50H = Cannot calibrate speed            61H = Unspool likely, no keys found            64H = EOT active            68H = BOT active            (Unit fault)</p>	
206	CE	<p>Load error (two bytes)</p> <p>This cartridge failed the load sequence. Failure is recorded in postbyte:</p> <p>1 = Load diagnostics failed            2 = Seek to EOT failed            3 = Speed calibration failed            4 = Gain set failed            5 = Seek to BOT failed            6 = Edge find failed            (Unit fault)</p>	
207	CF	<p>Unload error (two bytes)</p> <p>This cartridge did not successfully complete the normal unload sequence (logs may not have been updated). Failure is recorded in postbyte:</p> <p>1 = Diagnostic result indicated a hardware failure so normal unload was not attempted.</p> <p>2 = Seek to EOT failed            (Unit fault)</p>	

Table 11-6. Run-Time Drive Errors (DERRORS) (3 PCA) continued.

NUMBER		CAUSE or Test Description	SUSPECT HARDWARE
DEC	HEX		
209	D1	<p>Not certified</p> <p>This cartridge is not certified. (Uninitialized media)</p>	None
210	D2	<p>Certify command failed</p> <p>Attempt to certify a cartridge failed. Possible reasons are:</p> <p>1 Requires &gt;80% of the spares to be used up. 2 Can't write spares table to tape. 3 Error rate test failed due to log overflow or seek failure. 4 Transfer canceled 5 Certify specified with 0 loops.</p> <p>(Uninitialized media)</p>	
216	D8	<p>Hardware fail (one byte)</p> <p>Attempt to access the tape (with a non-diagnostic command) when previous diagnostic command, power-on or load diagnostics indicated a hardware failure. (Unit fault)</p>	
217	D9	<p>Write circuit failure (one byte)</p> <p>Attempt to perform a write command when write circuitry has failed power-on or load diagnostics or has failed a diagnostic command. (Unit fault)</p>	
223	DF	<p>No buffers in system (one byte)</p> <p>No buffers are available to complete transaction. (Controller fault)</p>	



#### 11-4. 2 PCA VERSION

The two PCA version first appeared in tape drives beginning at serial number prefix 2542A and 2542E (see Service Note 9144A-15). This included a single Read/Write Servo PCA which replaced the Read/Write and Servo PCAs. By using digital techniques the new PCA was the same size as one of the two PCAs it replaced. This RWS PCA did not obsolete the R/W and Servo PCAs. The circuitry remained functionally the same.

The replaceable parts which differ from the present version include:

09144 - 66515 SBCONT PCA  
09144 - 66518 RWS PCA  
09133 - 67120 PSU PCA (same as present version)

09144 - 04401 Chassis  
09144 - 61614 Cable SBCONT - RWS  
09144 - 61610 Cable Power  
09144 - 61612 Cable SBCONT - Front Panel PCA

The layout of the major electronic assemblies is shown in figure 11-27. Figures 11-28 to 11-29 show the PCAs. Figures 11-30 to 11-32 show the interconnections between the PCAs.

Figure 11-33 shows the order of disassembly. When using this chart refer to section 6 for appropriate safety warnings and cautions.

Table 11-7 shows the Diagnostic/Self-Test Errors (which are displayed as a result of performing self-tests) and their interpretation. Table 11-8 shows the Run-Time Drive Errors (which may occur at any time, as the result of a fault) and their interpretation.

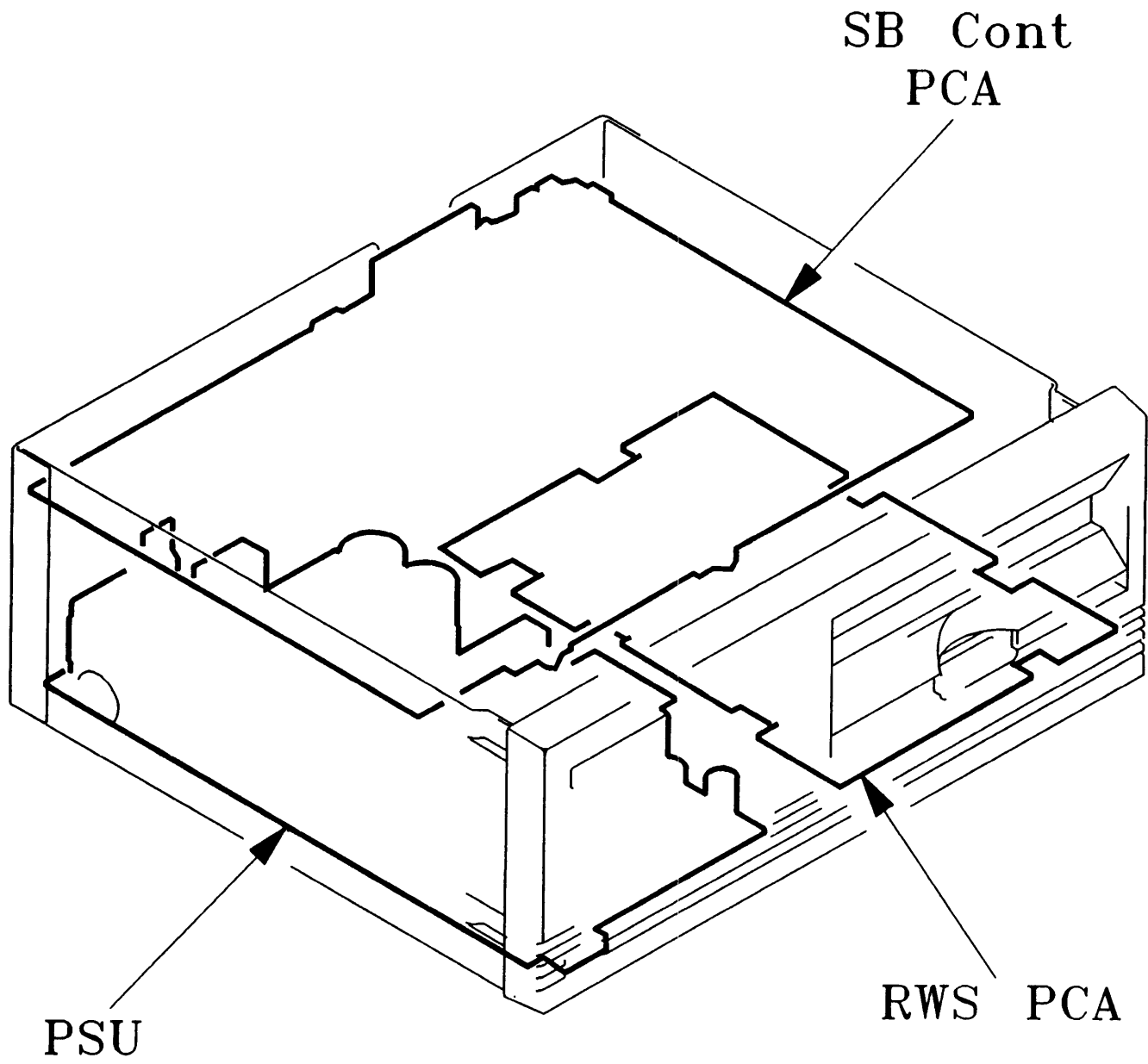

Figure 11-27. Location of PCAs (2 PCA version)

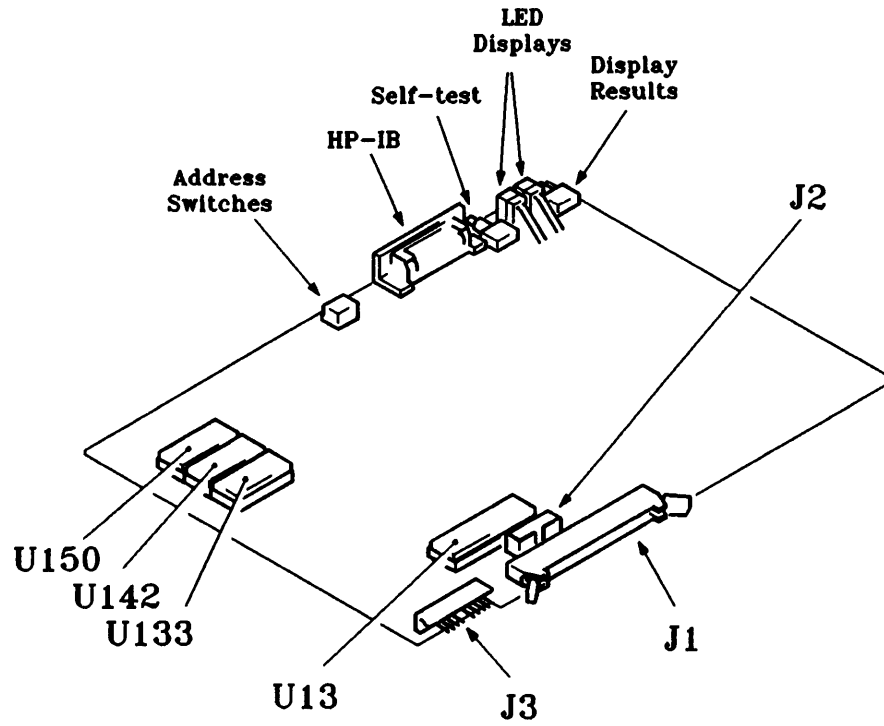

Figure 11-28. The SBCONT PCA (2 PCA version)

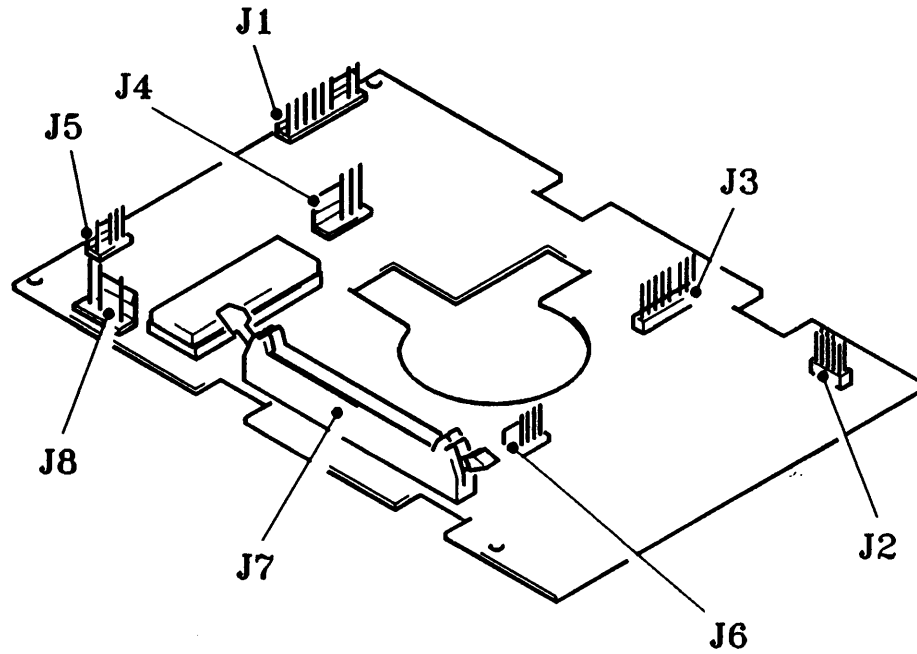

Figure 11-29. The RWS PCA (2 PCA version)

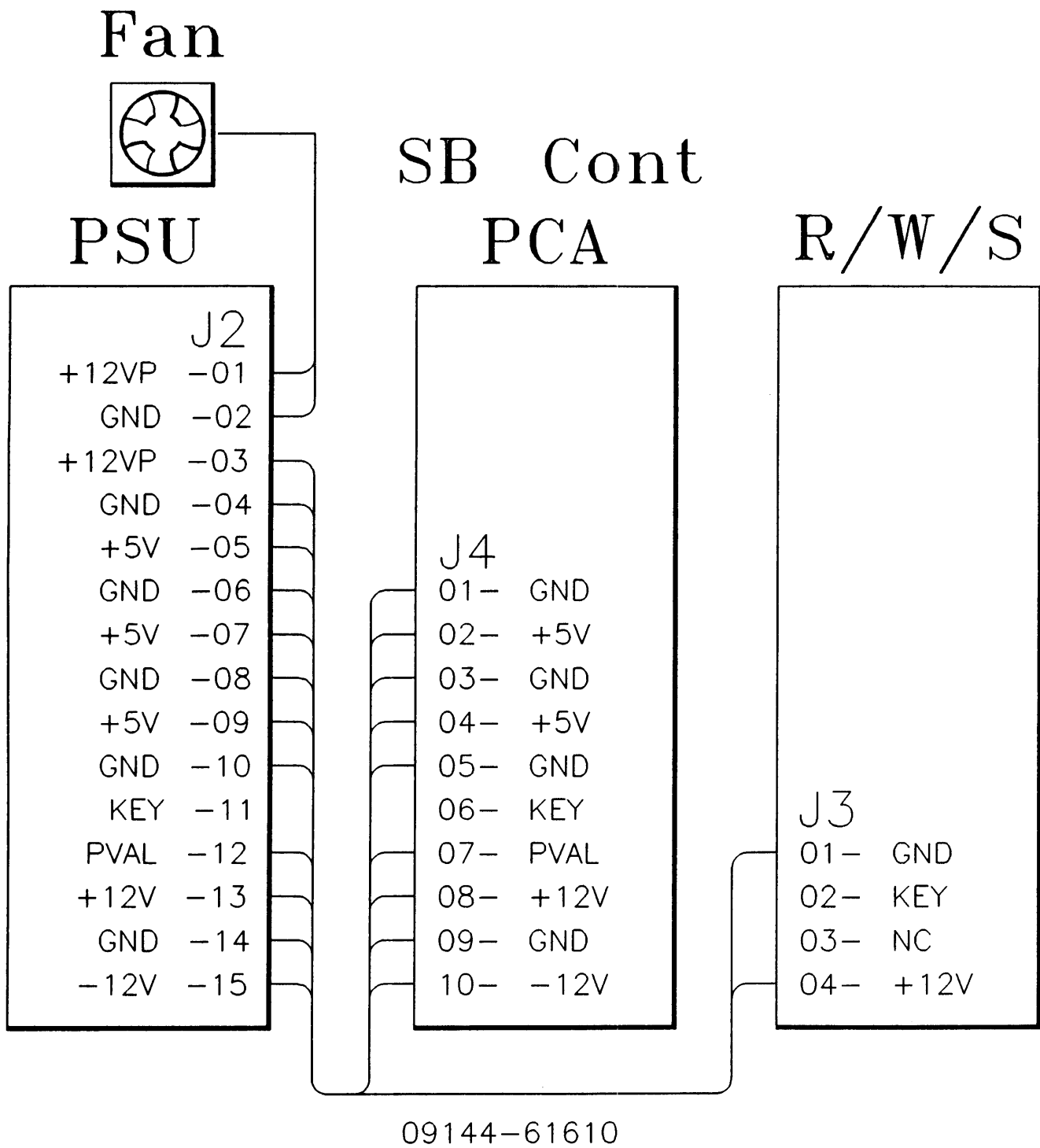

Figure 11-30. Power Cabling (2 PCA version)

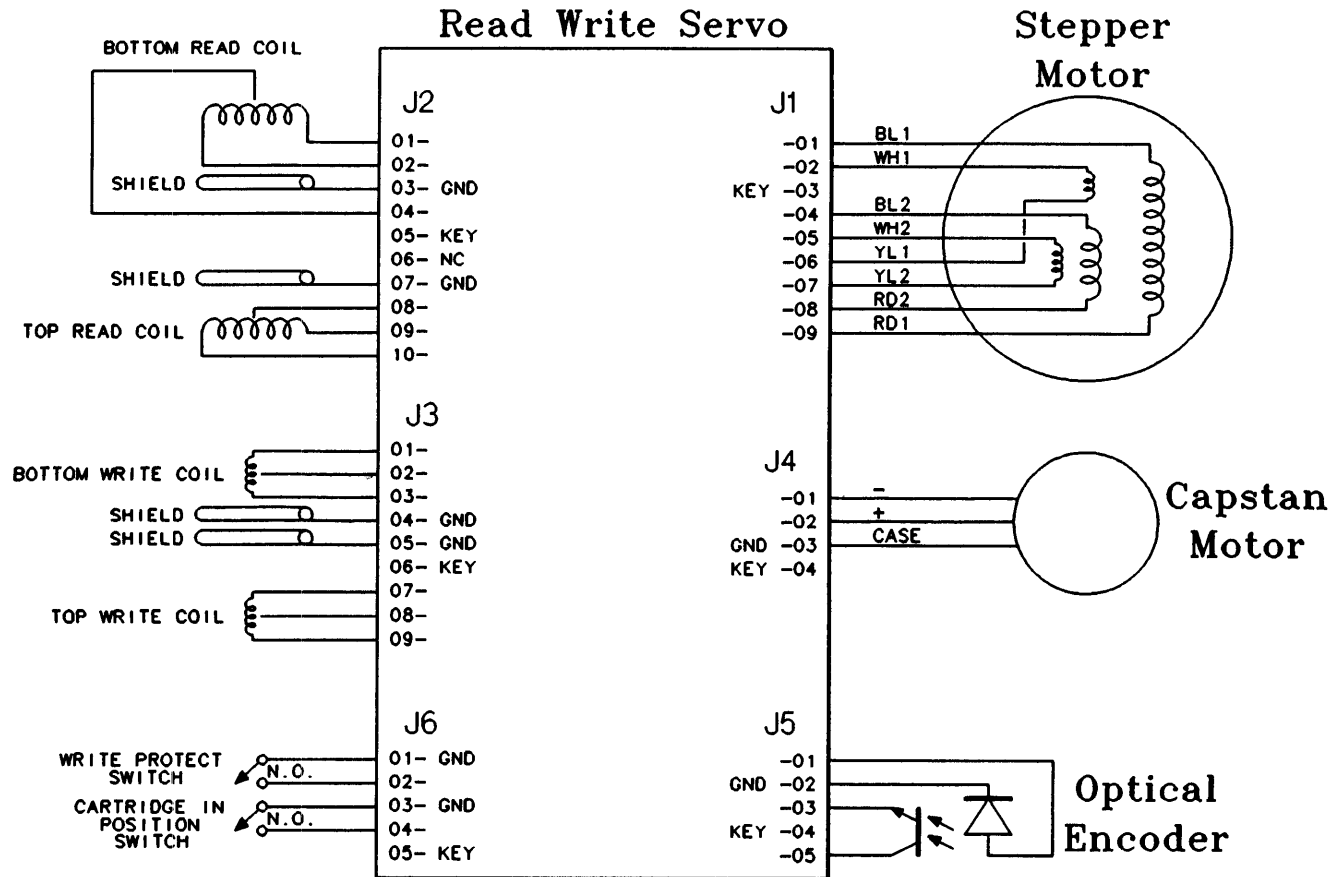

Figure 11-31. Drive Mechanism cabling (2 PCA version)

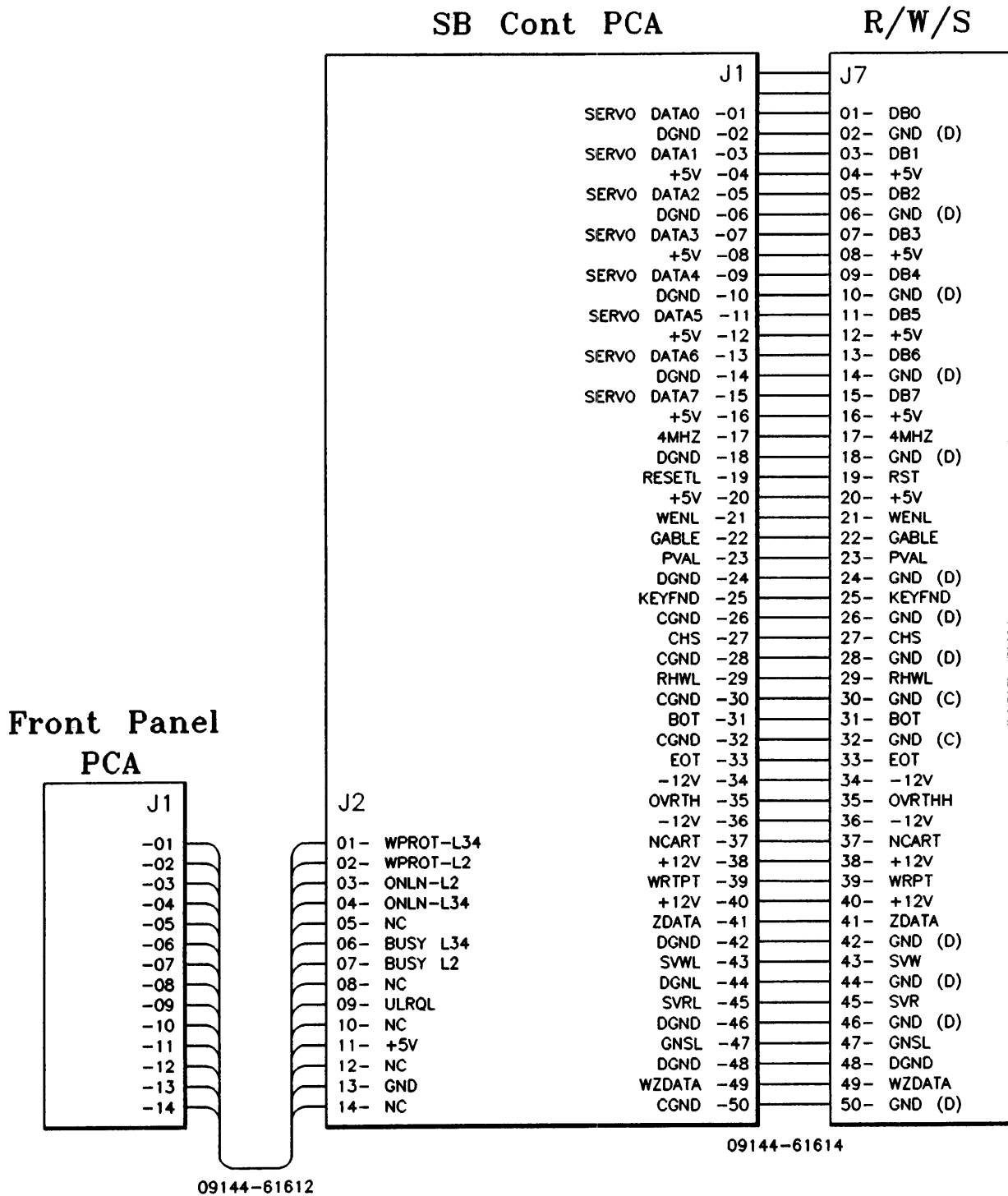

Figure 11-32. Signal Cabling (2 PCA version)

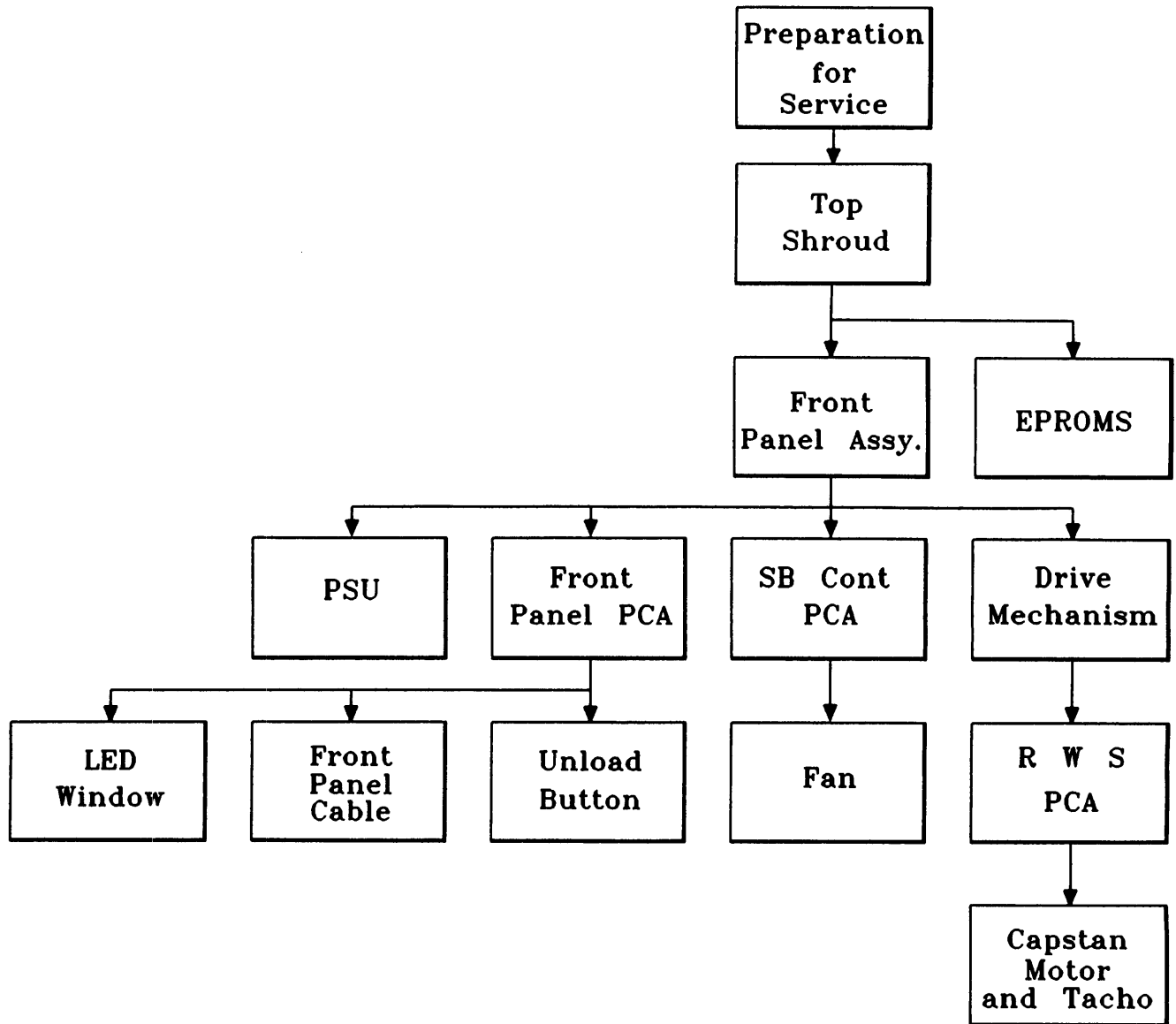

Figure 11-33. Order of Disassembly (2 PCA version)

Table 11-7. Diagnostic/Self-Test Errors (TERRORS) (2 PCA)

NUMBER		CAUSE or Test Description	SUSPECT HARDWARE
DEC	HEX		
00		Complete test of Tape Drive	
01		HDC-DDC interface. Read Servo Status	SBCONT
02		DDC Circuitry	
03		a) Microcomputer test	SBCONT
04		b) Read/Write loopback	SBCONT
05		HDC-DDC Read/Write loopback.	SBCONT
06		HDC-DDC-Servo Interface	RWS, SBCONT
07		Servo Circuitry	
08		a) Microcomputer	RWS
09		b) Capstan Motor Drive Circuit	RWS, Capstan Motor
10		c) Tachometer	RWS, Capstan Motor
11		d) Capstan Motor	Capstan Motor, RWS
12		e) Head Stepper Circuit	RWS and Head Stepper
13		Test the read portion of the RWS Circuitry  Start by executing a Put Gaps on Tape command. This will assume unit works and a Key Found signal can be generated. A failure of this command will cause the test to continue through the read tests, trying to diagnose what caused the failure. If the read tests all pass, the testing will halt and this test number will be the failing test.	RWS, SBCONT



Table 11-7. Diagnostic/Self-Test Errors (TERRORS) (2 PCA) continued

NUMBER		CAUSE or Test Description	SUSPECT HARDWARE
DEC	HEX		
14		With Read Gain set to minimum and Channel 0 positioned on the tape, enable Read with Read Head 0 and check for Overthreshold not being set.	RWS, SBCONT
15		With Read Gain set to minimum and Channel 0 positioned on the tape, enable Read with Write Head 0 and check for Overthreshold not being set.	RWS, SBCONT
16		With Read Gain set to a maximum and Channel 0 positioned on the tape, enable Read with Read Head 0 and check for overthreshold being set.	RWS, Head Stepper, SBCONT
17		With Read Gain set to maximum and Channel 0 positioned on the tape, enable Read with Write Head 0 and check for Overthreshold being set.	RWS, SBCONT
18		With Read Gain set to a minimum and Channel 1 positioned on the tape, enable Read with Read Head 1 and check for Overthreshold not being set.	RWS, SBCONT
19		With Read Gain set to a minimum and Channel 1 positioned on the tape, enable Read with Write Head 1 and check for Overthreshold not being set.	RWS, SBCONT
20		With Read Gain set to a maximum and Channel 1 positioned on the tape, enable Read with Read Head 1 and check for Overthreshold being set.	RWS, SBCONT
21		With Read Gain set to maximum and Channel 1 positioned on the tape, enable Read with Write Head 1 and check for Overthreshold being set.	RWS, SBCONT
22		Test the Write portion of the RWS PCA.	RWS
23		After the edge of tape has been found and the tape wound to BOT, execute a Locate and Write to track 0, Key 4 with Channel 0. Read back the written data and verify it is the same data that was written. If not, return an error.	RWS, SBCONT, Drive Mechanism
24		Execute a Locate and Write to track 7, Key 5 with Channel 1. Read back the written data and verify it is the same data that was written. If not, return an error.	RWS, SBCONT, Drive Mechanism

Table 11-8. Run-Time Drive Errors (DERRORS) (2 PCA).

NUMBER		CAUSE or Test Description	SUSPECT HARDWARE
DEC	HEX		
177	B1	<p>Recoverable dual errors (one byte)</p> <p>Two frames were bad (CRC error or missing) which were recoverable through XOR circuitry. (Marginal or recoverable)</p>	None
178	B2	<p>Single frame error (one byte)</p> <p>Only one frame with bad CRC or missing. (Marginal or recoverable)</p>	None
179	B3	<p>Unrecoverable data (one byte)</p> <p>Combination of frame CRC errors or missing frames such that data could not be recovered through XOR circuitry. (Marginal, recoverable or unrecoverable)</p>	None
180	B4	<p>DMA handshake error (one byte)</p> <p>Overflow or underflow has occurred between HDC and DDC. (Marginal, recoverable or unrecoverable)</p>	SBCONT
181	B5	<p>DMA failure (one byte)</p> <p>Not enough frames detected during read or read-while-write. (Marginal recoverable, or unrecoverable)</p>	SBCONT
185	B9	<p>Key error (one byte)</p> <p>One key past target, keys past target, bad key CRC, time-out of key sync, wrong key sent or verify failed. This error occurs during transfer, not seek to target or seek to perform retries. (Marginal, recoverable, unrecoverable, or latency induced)</p>	SBCONT
186	BA	<p>Seek error (one byte)</p> <p>Seek to target required retries or failed because of time-out or keys past target. (Unit fault)</p>	SBCONT

Table 11-8. Run-Time Drive Errors (DERRORS) (2 PCA) continued.

NUMBER		CAUSE or Test Description	SUSPECT HARDWARE
DEC	HEX		
187	BB	Seek to a jump spare (one byte)  A latency was induced due to seeking to a jump spare during transaction (Latency induced)	SBCONT
190	BE	Reposition failure (one byte)  Reposition of tape to next target address after tape access command required retries or failed. (Unit fault)	SBCONT
193	C1	Log overflow (two bytes)  Log indicated in postbyte overflowed. (Possible loss of entries)  0 = Manufacturer's block 1 = Sparing table 2 = Error rate test log 3 = Runtime error log 4 = Use log (Maintenance track overflow)	Tape Drive Subsystem: SBCONT, RWS Drive Mechanism
194	C2	Unable to read log (two bytes)  Log indicated in postbyte could not be read in multiple retries. (For sparing table, this could mean that it was never written or errors preclude it from being written. For other logs, if log was never written this error will not occur. Log will be returned as empty.) Postbyte log codes are defined above. (Unrecoverable data, uninitialized media, unit fault)	Uninitialized cartridge, Tape Drive Subsystem: SBCONT, RWS Drive Mechanism
195	C3	Unable to write log (two bytes)  Log indicated in postbyte could not be written on any track in multiple retries. Postbyte log codes are defined above. (Unrecoverable data)	
196	C4	Log only written on one track (two bytes)  Log indicated in postbyte could only be written on one track rather than the usual two. Postbyte log codes are defined above. (Unrecoverable data)	

Table 11-8. Run-Time Drive Errors (DERRORS) (2 PCA) continued.

NUMBER		CAUSE or Test Description	SUSPECT HARDWARE
DEC	HEX		
200	C8	<p>Servo error (two bytes)</p> <p>Command to servo processor was not successfully executed. Postbyte contains status returned by servo processor:</p> <p>00H = Power on state (servo processor is reset)            FFH = Busy/Active            1(T)H = Rewind/T = track            2(T)H = Forward/T = track            3(T)H = Stopped/T = track            40H = Invalid command            41H = Loss of speed control            44H = Cannot find edge of tape            48H = Pre-pos gaps, no keys            50H = Cannot calibrate speed            61H = Unspool likely, no keys found            64H = EOT active            68H = BOT active            (Unit fault)</p>	
206	CE	<p>Load error (two bytes)</p> <p>This cartridge failed the load sequence. Failure is recorded in postbyte:</p> <p>1 = Load diagnostics failed            2 = Seek to EOT failed            3 = Speed calibration failed            4 = Gain set failed            5 = Seek to BOT failed            6 = Edge find failed            (Unit fault)</p>	
207	CF	<p>Unload error (two bytes)</p> <p>This cartridge did not successfully complete the normal unload sequence (logs may not have been updated). Failure is recorded in postbyte:</p> <p>1 = Diagnostic result indicated a hardware failure so normal unload was not attempted.</p> <p>2 = Seek to EOT failed            (Unit fault)</p>	

Table 11-8. Run-Time Drive Errors (DERRORS) (2 PCA) continued.

NUMBER		CAUSE or Test Description	SUSPECT HARDWARE
DEC	HEX		
209	D1	<p>Not certified</p> <p>This cartridge is not certified. (Uninitialized media)</p>	None
210	D2	<p>Certify command failed</p> <p>Attempt to certify a cartridge failed. Possible reasons are:</p> <p>1 Requires &gt;80% of the spares to be used up. 2 Can't write spares table to tape. 3 Error rate test failed due to log overflow or seek failure. 4 Transfer canceled 5 Certify specified with 0 loops.</p> <p>(Uninitialized media)</p>	
216	D8	<p>Hardware fail (one byte)</p> <p>Attempt to access the tape (with a non-diagnostic command) when previous diagnostic command, power-on or load diagnostics indicated a hardware failure. (Unit fault)</p>	
217	D9	<p>Write circuit failure (one byte)</p> <p>Attempt to perform a write command when write circuitry has failed power-on or load diagnostics or has failed a diagnostic command. (Unit fault)</p>	
223	DF	<p>No buffers in system (one byte)</p> <p>No buffers are available to complete transaction. (Controller fault)</p>	

All the diagrams in this manual are to be found distributed throughout the text, as near as possible to the relevant text.



Manual Part Number: 07942-90903  
Printed in U.S.A., FEBRUARY 1987  
Edition 3  
E0297

