



HP 82483A

Surveying Pac

Owner's Manual

For the HP-71

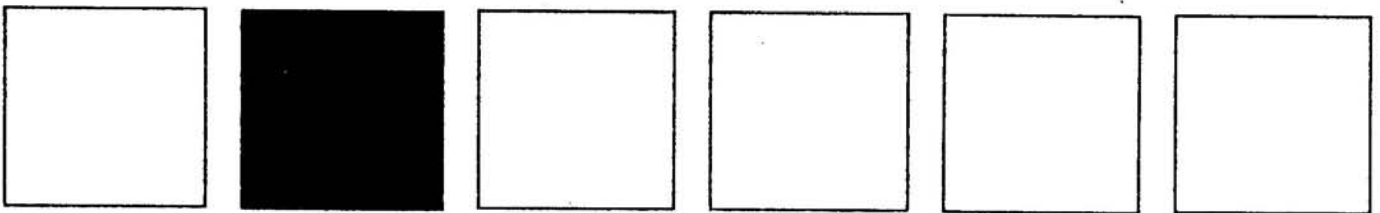

Printing History

Edition 1 November 1983; Manufacturing number 82483-90002
Edition 2 August 1984; Manufacturing number 82483-90003

Notice

Hewlett-Packard Company makes no express or implied warranty with regard to the keystroke procedures and program material offered or their merchantability or their fitness for any particular purpose. The keystroke procedures and program material are made available solely on an "as is" basis, and the entire risk as to their quality and performance is with the user. Should the keystroke procedures or program material prove defective, the user (and not Hewlett-Packard Company nor any other party) shall bear the entire cost of all necessary correction and all incidental or consequential damages. Hewlett-Packard Company shall not be liable for any incidental or consequential damages in connection with or arising out of the furnishing, use, or performance of the keystroke procedures or program material.



HP 82483A
Surveying Pac
Owner's Manual

For the HP-71

**Developed and written for Hewlett-Packard by
PacSoft Incorporated**

Edition 2

**Reorder Number
82483-90001**

Introducing the Surveying Pac

The Surveying Pac is a tool to aid the engineer and surveyor in solving many of the common surveying problems. Because it is one large integrated program, and not merely a collection of individual routines, the Surveying Pac exhibits power beyond what you might expect. It simply and easily handles all the calculations involved in:

- Traversing.
- Inversing.
- Curve layout.
- Radial staking.

Its unique data entry system allows inputs to be made in a variety of ways: by using bearings, north and south azimuths, angles left or right, and horizontal deflections left or right. You can choose your input modes regardless of the mode of output you desire. If entries are unknown, the program will ask other questions until enough is known about the situation for an answer to be computed.

Contents

How To Use This Manual	7
Section 1: Getting Started	9
• Contents • Installing and Removing the Surveying Module	
• How to Use the Surveying Pac • Exiting the Surveying Pac	
• Conventions Used by the Surveying Pac Programs • Output	
Section 2: File Management	23
• Contents • Introduction • Assign Routine	
• List Coordinates Routine • Clear Coordinates Routine	
• Duplicate Points Routine	
• Balance Traverse and Adjustment Routines • Rotate Points Routine	
• Translate Points Routine • Scale Coordinates Routine	
Section 3: Coordinate Geometry	33
• Contents • Introduction • Start Routine • Lines Routine	
• Curves Routine • Radial Stakeout Routine	
• Area/Traverse Computations	
Section 4: Examples	57
• Contents • Introduction	
• Example 1: File Creation and Coordinate Storage	
• Example 2: Field Traverse	
• Example 3: Duplicate Points and Balance Traverse	
• Example 4: Display Traverse and Compute Area	
• Example 5: Solve Roadway Center Line and Curb Line	
• Example 6: Subdivision • Example 7: Lot Summary	
• Example 8: Radial Stakeout	

Appendix A: Owner's Information	103
Appendix B: Error Conditions and Recovery	110
Appendix C: Programs and Subprograms	112
Appendix D: The Coordinate File	120
Appendix E: Glossary	121
Subject Index	124

How to Use This Manual

This manual contains detailed information on the operation of the routines in the Surveying Pac. The explanations assume that you know how to use the HP-71 to the level described in sections 1 and 6 of the *HP-71 Owner's Manual*. It also assumes that you are familiar with the procedures used in surveying.

There are four sections in this manual. The first one, "Getting Started," introduces you to the use of the Surveying Pac: how to install it, how to begin each surveying problem, and how to establish what measurement conventions you want to use.

The second section, "File Management," explains the manipulation of individual coordinate points: how to enter, clear, list, duplicate, rotate, and translate coordinates. This section also includes a routine for traverse balancing.

The third section, "Coordinate Geometry," handles angular and linear relationships between two or more coordinate points. This includes the following routines to solve for new points: traverse, bearing-bearing intersection, bearing-distance intersection, distance-distance intersection, curve traverse, and inscribe curve. Other routines return information on the relationship between already solved points. These are the computations for the inverse, curve inverse, radial stakeout, traverse reprint, and area.

The fourth section, "Examples," presents eight surveying problems and their solutions using this pac.

The appendixes contain reference information:

- Appendix A, "Owner's Information," has warranty and service information.
- Appendix B is "Error Conditions and Recovery" for this pac. (For other error conditions, refer to the *HP-71 Owner's Manual*.)
- Appendix C, "Programs and Subprograms," lists the programs and subprograms available in the Surveying Pac.
- Appendix D, "The Coordinate File," shows the format of the coordinate file created when you run the program SURVEY.
- Appendix E is a short glossary of the surveying terms used in this manual.

A complete subject index is also included at the end of this manual.

Section 1

Getting Started

Contents

Installing and Removing the Surveying Module	9
How to Use the Surveying Pac	10
Running SURVEY	10
Where to Go From Here	12
Exiting the Surveying Pac	12
Conventions Used By the Surveying Pac Programs	12
Menus	12
Program Files	14
The Coordinate File	14
Input and Output Options	15
Data Entry	15
Angles	15
Directions	16
Distances	21
Point Numbers	21
Coordinates	22
Output	22

Installing and Removing the Surveying Module

The surveying module can be plugged into any of the four ports on the front edge of the computer.

CAUTIONS

- Be sure to turn off the HP-71 (press OFF) before installing or removing any module. If the computer is on while a module is being installed or removed, it might reset itself, causing all stored information to be lost.

CAUTIONS (CONTINUED)

- If you have removed a module to make a port available for the surveying module, before installing the surveying module, turn the computer on and then off to reset internal pointers.
- Do not place fingers, tools, or other foreign objects into any of the ports. Such actions could result in minor electrical shock hazard and interference with pacemaker devices worn by some persons. Damage to port contacts and internal circuitry could also result.

To insert the surveying module, orient it so that the label is right-side up, hold the computer with the keyboard facing up, and push in the module until it snaps into place. During this operation be sure to observe the previously described precautions.

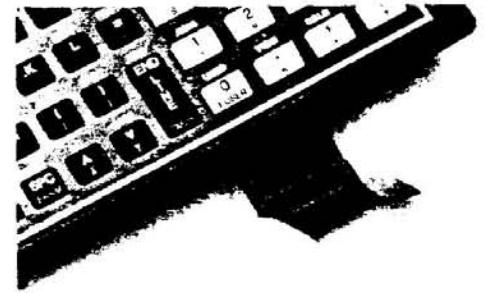

To remove the module, use your fingernails to grasp the lip on the bottom of the front edge of the module and pull the module straight out of the port. Install a blank module in the port to protect the contacts inside.

How to Use the Surveying Pac

The Surveying Pac is a system for solving surveying problems. You always start out by running SURVEY. SURVEY asks for information and provides several options for you to follow. In other words, SURVEY sets up or *initializes* the conditions for solving your particular problem.

Running SURVEY

Let's start by looking at an example of SURVEY to see how you will run the program when you get to the examples in section 4. This example is designed to be read and not keyed in. It will explain the meaning and purpose of SURVEY's features, and why your input to the computer must follow certain conventions. One of the first things that SURVEY does is create a file—called a *coordinate file*—to store the coordinate points for your current problem. To create the coordinate file, the program asks you for a file name and file size.

Step	Display	Instructions
1		Turn the HP-71 on and switch to BASIC mode.
2	>	Type RUN SURVEY <input type="text" value="END LINE"/> to run the SURVEY program.
3	file name █	Enter a name for the coordinate file. (File names can be up to eight letters and digits long, and must begin with a letter.) If the file name you specify already exists, SURVEY skips to step 11.
4	size (nnn max) █	For the coordinate file size, enter the number of data points you will be using, which cannot be more than the maximum shown. *
5	abs angl Brg,Naz,Saz█	Select Bearings (<input type="text" value="B"/>) , North azimuths (<input type="text" value="N"/>) , or South azimuths (<input type="text" value="S"/>) for the output of the resulting directions. You do not need to press <input type="text" value="END LINE"/> .
6	field angl Defl,Angl█	Select Deflection angles (<input type="text" value="D"/>) or Angles left/right or interior/exterior (<input type="text" value="A"/>) for the output of field angles.
7	Degrees,Grads█	Select Degrees (<input type="text" value="D"/>) or Grads (<input type="text" value="G"/>) for the output of angular units.
8a	secs #decs (0-2)█	If you selected Degrees in step 7, specify the number of decimal places (up to two) for the output of the seconds.
8b	grads #decs (0-6)█	If you selected Grads in step 7, specify the number of decimal places (up to six) for the output of the grads.
9	coords #decs (0-5)█	Select the number of decimal places for the output of the coordinates.
10	distances #decs (0-5)█	Select the number of decimal places for the output of distances.
11	working File,Cogo,User,Ex█	

In a real situation, SURVEY will have created a coordinate file to your specifications. You would now be ready to start surveying! Pressing accesses the File Management program, pressing accesses the Coordinate Geometry (COGO) program, pressing accesses a program that you have created and stored in HP-71 memory, and pressing exits the Surveying Pac.

* If you need more memory, you can make more room available by purging files currently in memory. You might want to copy the files to cards or a cassette first. Refer to "Copying Files" in section 6 of the *HP-71 Owner's Manual* for copying to cards, or to section 3, "Mass Storage Operations" in the *HP 82401A HP-IL Interface Owner's Manual* for copying to a cassette.

When you return to the Surveying Pac at a later time to use the same set of data (and therefore the same coordinate file), you will still start with `RUN SURVEY`, but the process will be much shorter. You need only enter the name of the coordinate file. Since the desired coordinate file already exists, `SURVEY` will skip all of the preliminary questions and go directly to the last line, asking you which surveying program you want.

Where to Go From Here

After initializing the Surveying Pac by running `SURVEY`, you can proceed to one of three surveying programs:

- `File`. The File Management program will manipulate points that already exist in a coordinate file. Go here if you want to list, delete, or enter points, or if you want to rotate or translate them. This description begins on page 23.
- `Cogo`. The Coordinate Geometry program takes a known starting point and computes a new point or points. This description begins on page 33.
- `User (SURV3)`. `User` accesses a BASIC program, named `SURV3`, that is stored in memory. It is not part of the Surveying Pac. This option allows you to access an additional program of your choice while using the Surveying Pac.

Exiting the Surveying Pac

When you are finished with the Surveying Pac, you can stop its execution by pressing `[E]`. You can then turn off the HP-71 or work on other problems. Pressing `[ATTN]` suspends program execution (the `SUSP` annunciator turns on). You can continue program execution by pressing `[f] [CONT]` or start over by pressing `[RUN]`.

Running the Surveying Pac creates and stores the coordinate file. For safety, you should copy the coordinate file to a card or cassette if you plan to do more work with these coordinate points.

Conventions Used by the Surveying Pac Programs

The Surveying Pac programs use various modes, parameters, options, and files. These conventions are defined below.

Menus

The Surveying Pac contains several different routines for various solutions. These routines are accessed by a series of *menus*. A menu is a list of options from which you can select a programmed routine or function. For example, the menu at the end of `SURVEY` looks like:

File, Cogo, User, Ex ■

To select the File program, press the **[F]** key, which leads to the next menu in that series of menus. **[C]** selects the Cogo program, which also leads to another menu, while **[U]** selects the user program, SURV3. **[E]** exits the program.

In all the menus, the capital letters indicate which keys to press to get the corresponding function. Where multiple menus exist at the same level, the **[v]** key (indicated by a lowercase v in the menu) moves between menus.

The following flowchart shows the main surveying menu and its secondary menus.

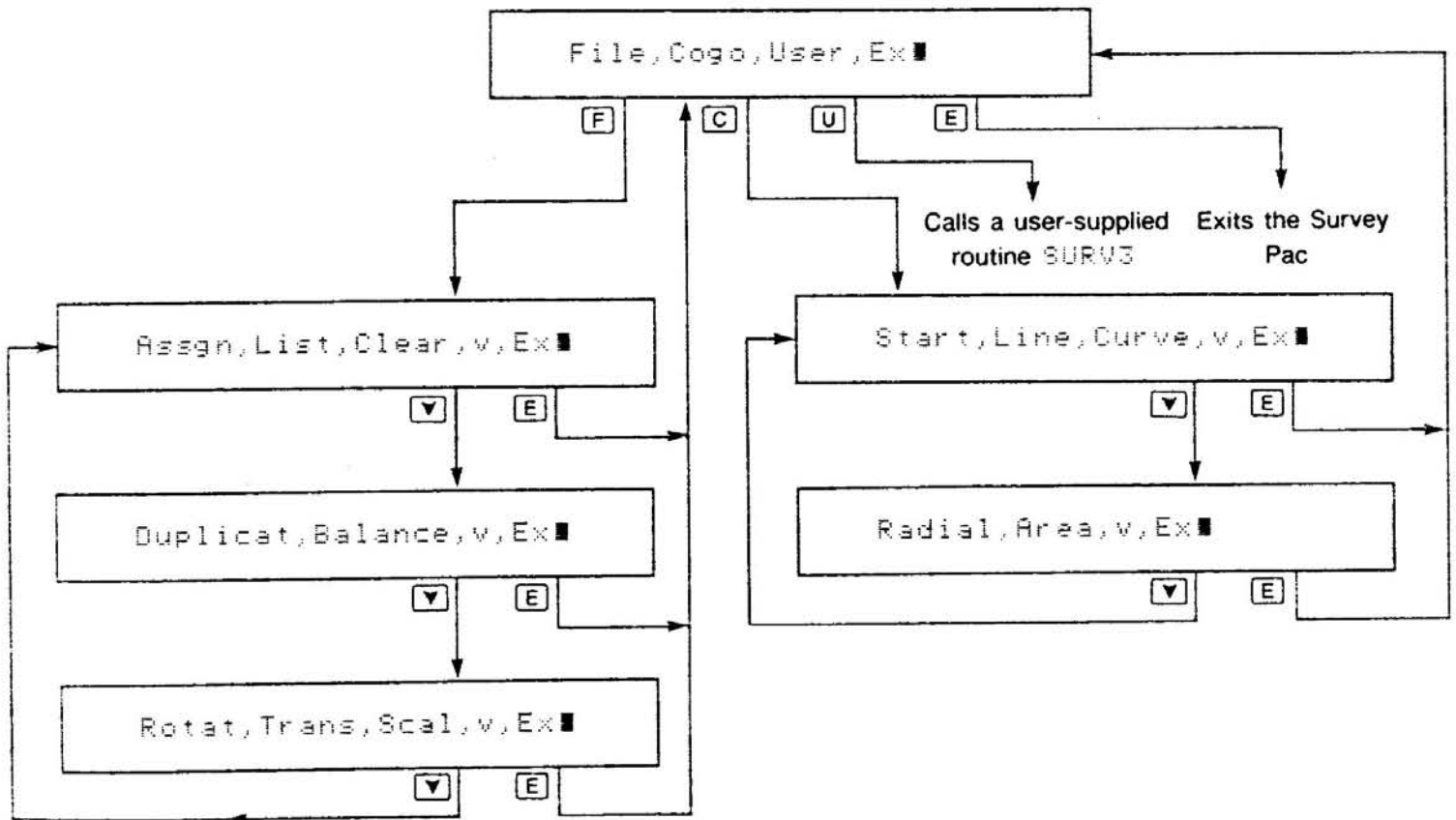

Program Files

The menus in the Surveying Pac allow you to transfer from one routine to another. In addition, the main SURVEY program can switch activity to a subprogram named SURV3. SURV3 is not part of the Surveying Pac; rather, it is the name of a potential program that you (or anyone else) can write and store in HP-71 memory. This option allows you to add alternate solutions and incorporate them into the Surveying Pac routines. SURV3 is accessed by pressing from the main surveying menu.

The Surveying Pac also contains a number of smaller utility subprograms that you can call from your own BASIC programs. Refer to appendix C, "Programs and Subprograms," for a list and description of those subprograms.

Note: When you name programs or data files, take care to choose file names different from those in the Surveying Pac (as well as other application modules). Appendix C contains a list of the file names used in this pac.

The Coordinate File

All routines in the Surveying Pac write to and read from a *coordinate file*. This file contains northings, eastings, and elevations for all coordinate points that you enter or calculate. The points are referenced by *point numbers*, which can range from 1 to 999.

The coordinate file is stored in the user memory (random access memory or RAM) of the HP-71. The maximum possible size of the file depends on the memory available. Before beginning, you might want to purge unneeded programs or data to make more room for the coordinates. Refer to "Purging Files," in section 6 of your owner's manual for instructions.

The coordinate file is referenced by a name that you assign. The name can be from one to eight characters long. The first character must be a letter; the remaining characters can be letters or digits. The file name must be unique—no other file of the same name can exist in memory at the same time.

A coordinate file is created automatically when you run SURVEY. This program will request a name for the coordinate file. The program will also have you specify the file size, unless the file was created in an earlier run. When a new file is created and its size specified, space is allocated and all coordinates are *cleared* (set to an unassigned status).

Several different coordinate files can be stored in the HP-71 at the same time as long as the names are different and sufficient space exists. This allows you to maintain coordinates for various jobs in separate files.

Coordinate files can be copied to cards or cassettes via the COPY command (refer to section 6 in the *HP-71 Owner's Manual* for information on copying to cards and section 3 in the *HP 82401A HP-IL Interface Owner's Manual* for information on copying to cassettes). Cards and cassettes provide you with a permanent record of your work on a particular job. Once the file has been copied, you can purge it from memory to make room for other files. When you need to access the coordinates again, copy the file back to the HP-71 memory. In any case, making copies of a file is a good idea for protection in case of accidental loss of data caused by battery failure or a system reset.

You can access the coordinate file from your own (BASIC) programs. Appendix D, "The Coordinate File," contains information on the file structure.

Input and Output Options

The Surveying Pac offers a variety of options for the formats of both inputs and outputs. You can specify angular units in either degrees or grads. You can specify the number of decimal places displayed for angles, coordinates, and distances.

Directions can be output as bearings, north azimuths, or south azimuths. Field angles can be either angles left or right or deflections left or right.

Regardless of the output mode, you can still enter *input* by any method: bearings, north or south azimuths, angles left or right, and deflections left or right.

You make these selections whenever a new coordinate file is created.

Data Entry

Whenever input is required, a prompt is displayed. You should end all data entry by pressing **END LINE**, unless you are making a menu selection. When two or more values are required, separate them with a comma.

When a prompt contains one or more items inside square brackets, those items are optional. For example, when `hrz[] ; vrt [] d[st] ■` is displayed, an entry for the horizontal distance is required, while the vertical distance entry is optional. If you enter the optional value, *a semicolon must separate it from the first value.*

The Surveying Pac programs check all input for validity. If an entry is not understood by the system, the computer will display a warning message. You can then reenter the data.

Angles

You can work with one of two angular units—degrees or grads. If you select degrees, enter angles in the form *DD.MMSS*. If you need decimal seconds, you can show them in the fifth decimal place: for example, 15°31'16.2" would be entered as 15.31162. If you select grads, simply enter angles as the decimal number of grads.

Entries for angles can appear as mathematical expressions involving addition, subtraction, or division. The following examples are valid angular entries in the Surveying Pac.

31.20

Equals 31°20' or 31.2 grads.

47.3124 + 90.4

Equals 138°11'24" or 137.7124 grads.

133.4651/2 - 30.5

Equals 36°03'26" or 36.2326 grads.

180 + 15.43/3

Equals 185°14'20" or 185.1433 grads.

Note: Parentheses and multiplication are not allowed in angular expressions. If multiplication is used in an angular expression, it will be ignored; i.e., 1*2+3 results in an angle of 4 degrees. Also, the order of expression follows the HP-71 mathematical hierarchy of expression (refer to "Precedence of Operators" in section 2 of your owner's manual).

Wherever this manual tells you to enter an *angle*, it means that you can specify angles in any of the valid forms described above.

Directions

You can establish directions by:

- Entering an angle from an actual or assumed meridian (bearings, north azimuths, or south azimuths).
- Entering a field angle relative to the reference direction (angles left or right, deflections left or right).
- Using previously solved points to define the direction.

Bearings. Bearings are measured clockwise and counter-clockwise from either a north or south meridian.

To enter a bearing, precede the angle with a two-letter quadrant (NE, NW, SE, or SW):

NE *angle*

NW *angle*

SE *angle*

SW *angle*

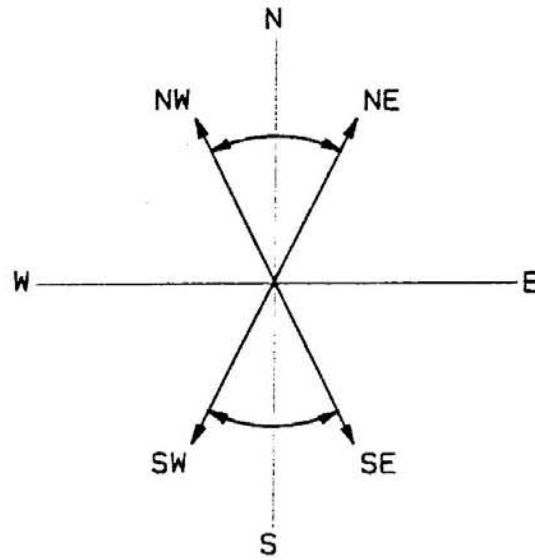

Bearings

Azimuths. Azimuths are measured clockwise from a north (north azimuth) or south (south azimuth) meridian.

To enter a north azimuth, simply enter the angle. To enter a south azimuth, either precede the angle with the SW quadrant notation, or add 180° (200 grads) to the north azimuth:

angle
SW angle
angle +180

North azimuth.
 South azimuth.
 South azimuth.

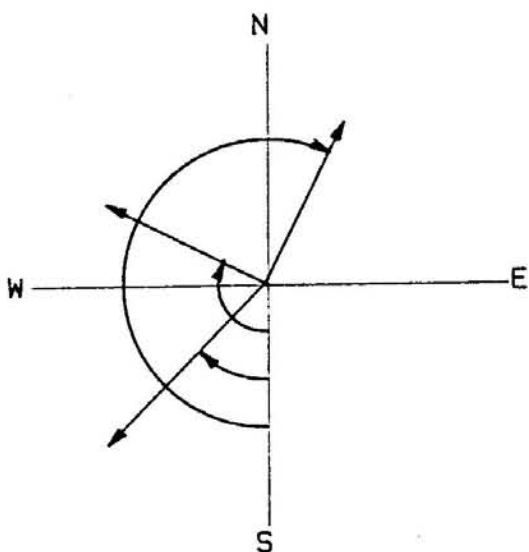

South Azimuths

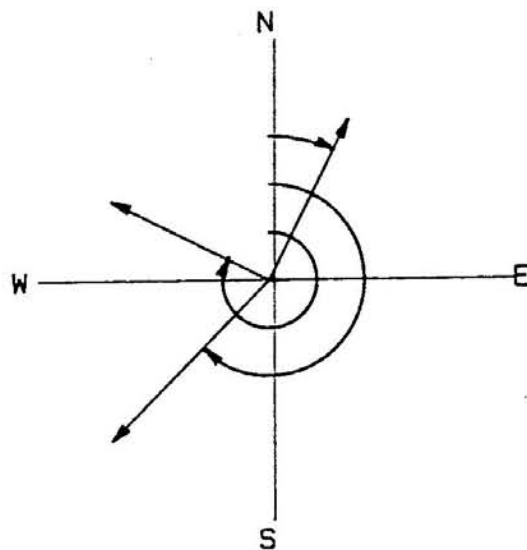

North Azimuths

Angles Right and Angles Left. Angles right and left are measured from a reference backsight that is usually the previous leg of a traverse.

To enter angles right, precede the angle with a plus. To enter angles left, precede the angle with a minus:

+ *angle*

Angle right.

- *angle*

Angle left.

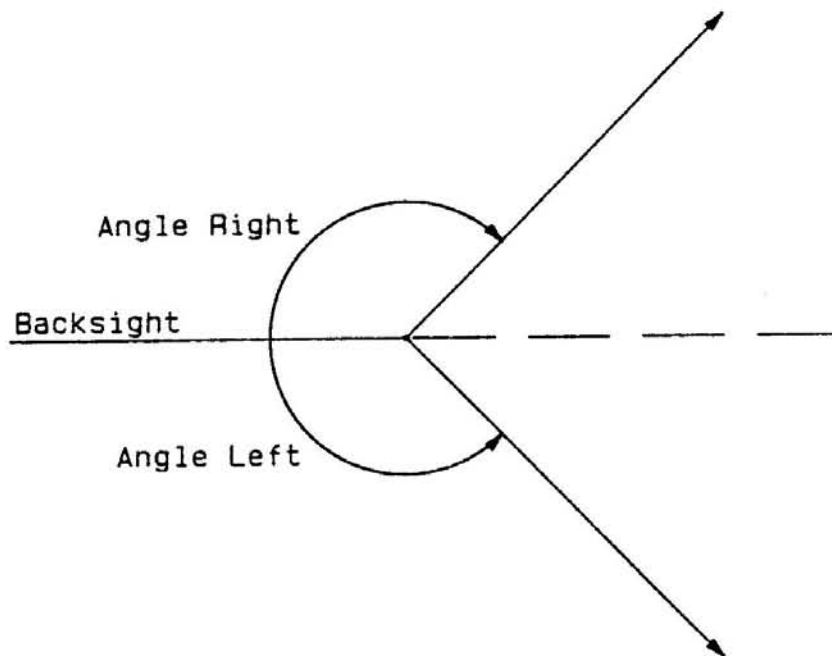

Deflection Angles. Deflection angles are turned from an extension of the previous traverse leg or backsight.

Since deflection angles differ from angles left or right by 180° (200 grads), enter deflection angles as an angle plus 180°:

+ angle +180	Deflection right.
- angle +180	Deflection left.

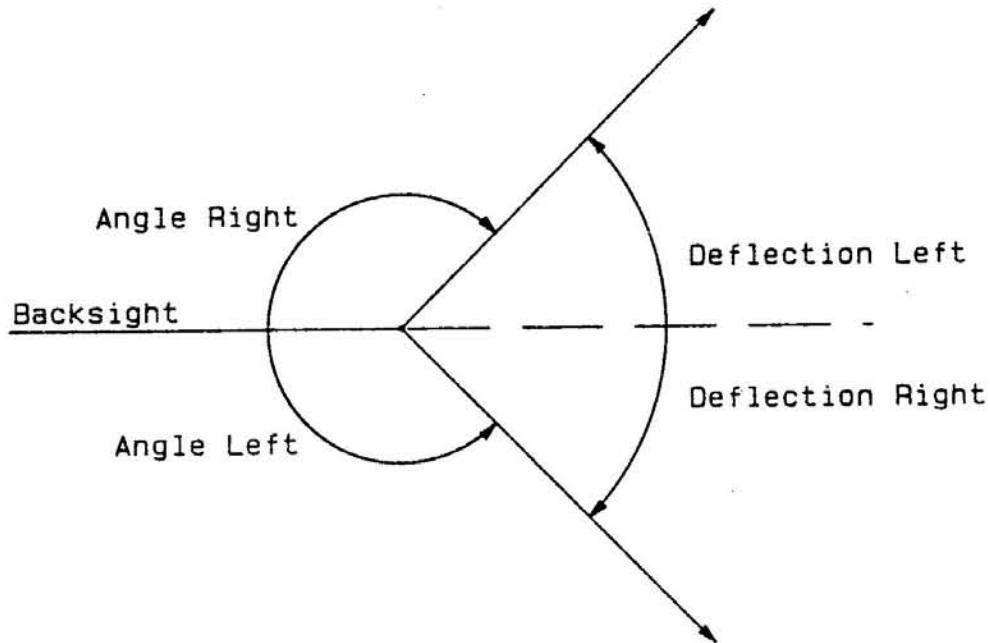

Defined Direction. A direction can be *defined* by two existing points.

Given two defined points, $p1$ and $p2$, you can enter a defined direction as:

$$p1 * p2$$

The two defined points must have assigned coordinates. Whenever you enter a direction defined by two points the points must be separated by an asterisk.

An angular entry (in any of the allowable forms) can be added to or subtracted from a defined direction:

$$p1 * p2 + angle$$

$$p1 * p2 - angle$$

Distances

There are three ways to enter distance values:

- Enter the numeric distance, for instance, 482.5.
- Enter a *defined distance* using previously solved points. For example, to indicate the defined distance between point #4 and point #8, enter 4*8 (the points must be separated by an asterisk).
- Enter an expression that adds, subtracts, or divides an actual or defined distance. For instance, $482.5 + 357.9 / 2$.

Following are examples of valid distance entries:

132.6

4*8

The distance between points 4 and 8.

100/4

25.

6*2/3

One-third of the distance from point 6 to point 2.

300-41*42

Three hundred minus the distance between points 41 and 42.

137.9+7*9/2

137.9 plus half the distance between points 7 and 9.

Point Numbers

You can input a point number directly, or you can enter it as the next consecutive point by entering a +. The + enters the next point relative to the last point entered. When you first run SURVEY, the last point entered is considered to be 0.

Coordinates

When assigning coordinates to a point, you must enter values for the northing and easting. Elevation input is optional—if you don't need it, simply press **END LINE** when the display prompts:

H of #p ■

There are several instances when a surveying routine requires the input of a point number with known coordinates. If the point number you use is unassigned, you must enter the coordinates at that time. The coordinates will be stored, and you can continue with the problem.

Output

Normally, you will see any output (solved coordinates, bearings, distances, and so on) on the HP-71 display. If the display does not last long enough for you to read it or copy it down, interrupt the program by pressing **ATTN** and use the HP-71 **DELAY** command to change the duration of the display. You may also set the **DELAY** rate before you run **SURVEY**. For example, to have each line displayed for 3 seconds, enter **DELAY 3 END LINE**. An effective way to scroll through the display at your own rate is to interrupt the program with the **ATTN** key and specify a delay of 8 or more; this causes the output to remain in the display until any key is pressed (**END LINE** is a good one).

When a delay is selected, it remains in effect until another **DELAY** command is executed. The delay can be overridden by pressing any key. Note that the delay rate also affects the display rate of error and status messages.

The Surveying Pac programs do not require a printer for operation. However, if one is available, all output can be directed to it.

For a complete explanation on how to direct output to a printer, refer to your *HP-71 Owner's Manual*, section 13.

Section 2

File Management

Contents

Introduction	23
Assign Routine	26
List Coordinates Routine	26
Clear Coordinates Routine	27
Duplicate Points Routine	27
Balance Traverse and Adjustment Routines	27
Angle Balance	27
Bowditch Rule	28
Crandall's Rule	28
Elevation Adjustment	28
Traverse Input and Adjustment	29
Balance Routine	29
Rotate Points Routine	30
Translate Points Routine	31
Scale Coordinates Routine	31

Introduction

This section contains information on the File Management program. It covers the menus for accessing the various routines, the purposes of the routines, and examples of how to use the routines. The examples are designed to be read and not keyed in. Section 4 contains numerous examples showing the actual use of the routines for you to key in.

The File Management program contains routines that allow you to directly access and manipulate the points in a coordinate file. Three menus display the available functions:

Assgn, List, Clear, v, Ex■

- Press **A** to access the Assign routine that assigns coordinate values to selected points.
- Press **L** to access the List Coordinates routine that lists the northing, easting, and elevation of all assigned points that are specified.
- Press **C** to access the Clear Coordinates routine that clears coordinate values.
- Press **▼** to display the next menu.
- Press **E** to return to the File, Cogo, User, Ex■ menu.

Duplicat, Balance, v, Ex■

- Press **D** to access the Duplicate Points routine that duplicates stored points.
- Press **B** to access the Balance Traverse routines that distribute the errors in a traverse.
- Press **▼** to display the next menu.
- Press **E** to return to the File, Cogo, User, Ex■ menu.

Rotat, Trans, Scale, v, Ex■

- Press **R** to access the Rotate Points routine.
- Press **T** to access the Translate Points routine.
- Press **S** to access the Scale Coordinates routine that applies a scale factor.
- Press **▼** to display the Assgn, List, Clear, v, Ex■ menu again.
- Press **E** to return to the File, Cogo, User, Ex■ menu.

The following flowchart shows the relationship between these three menus and the main surveying menu.

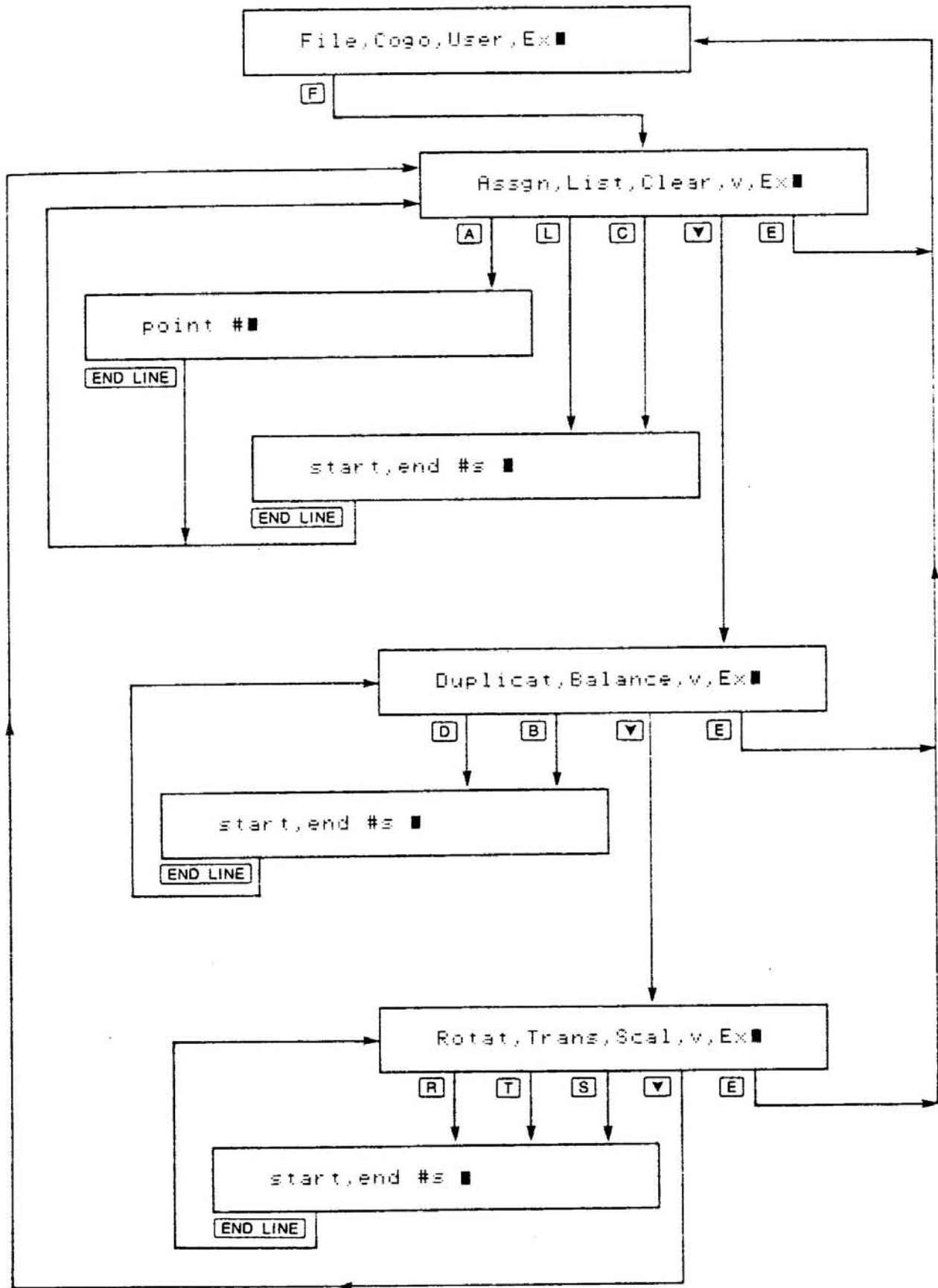

Assign Routine

Purpose: Assigns coordinate values to selected points.

Step	Display	Instructions
1	Assgn, List, Clear, v, Ex ■	Press A .
2	point # ■	Enter the point number you want to store. or Enter a + to use the next sequential point number. or Press END LINE with no entry to return to the menu in step 1.
3	N, E of #p ■	Enter the northing and easting of the selected point, separated by a comma.
4	H of #p ■	Enter the elevation. or If no elevation is needed, press END LINE .
5	working	After the coordinates are displayed, continue with step 2.

List Coordinates Routine

Purpose: Provides a listing of the northing, easting, and elevation for all assigned points within a user-defined range of point numbers.

Step	Display	Instructions
1	Assgn, List, Clear, v, Ex ■	Press L .
2	start, end #s ■	Enter the point numbers of the first and last points you want listed (separated by a comma).
3	working	The points are listed on the selected device (display or external printer). When this is done, the display returns to the menu in step 1.

Clear Coordinates Routine

Purpose: Clears points by resetting the coordinates to an unassigned status.

Step	Display	Instructions
1	Assgn, List, Clear, v, Ex ■	Press [C] .
2	start, end #s ■	Enter the point numbers of the first and last points you want cleared (separated by a comma).
3	working	After the points have been cleared, the display returns to the menu in step 1.

Duplicate Points Routine

Purpose: Makes a copy of a point or block of points. New point numbers are assigned to the duplicate points, and the original points remain intact.

Step	Display	Instructions
1	Duplicat, Balance, v, Ex ■	Press [D] .
2	start, end #s ■	Enter the point numbers of the first and last points of the block of points you want duplicated (separated by a comma).
3	new start # ■	Enter the first point number you want assigned to the new points.
4	working	After the points have been copied, the display returns to the menu in step 1.

Balance Traverse and Adjustment Routines

The Surveying Pac contains three routines for distributing the errors in a traverse: angle balance, Bowditch rule adjustment, and Crandall's rule adjustment. If there is no error in the horizontal closure, the entire balance is bypassed, even if there is error in the vertical closure.

Angle Balance

For an angle balance, it is assumed that the angular error is the same at each station. The total correction that you input is divided by the number of legs in the traverse. The resulting angular correction is applied to each leg.

Bowditch Rule

The Bowditch (or Compass) rule distributes the errors in latitude and departure in proportion to the length of each leg:

$$\frac{\text{Correction in Latitude}}{\text{Length of Leg}} = \frac{\text{Total Error in Latitude}}{\text{Total Traverse Length}}$$

$$\frac{\text{Correction in Departure}}{\text{Length of Leg}} = \frac{\text{Total Error in Departure}}{\text{Total Traverse Length}}$$

Crandall's Rule

Crandall's rule employs the following variation of a least squares adjustment:

$$A = \frac{e_D \left(\sum \frac{LD}{l} \right) - e_L \left(\sum \frac{D^2}{l} \right)}{\left(\sum \frac{D^2}{l} \right) \left(\sum \frac{L^2}{l} \right) - \left(\sum \frac{LD}{l} \right)^2}$$

$$B = \frac{e_L \left(\sum \frac{LD}{l} \right) - e_D \left(\sum \frac{L^2}{l} \right)}{\left(\sum \frac{D^2}{l} \right) \left(\sum \frac{L^2}{l} \right) - \left(\sum \frac{LD}{l} \right)^2}$$

$$C_L = \frac{L}{l} (AL + BD)$$

$$C_D = \frac{D}{l} (AL + BD)$$

where L is the latitude of any leg, D is the departure of any leg, l is the length of any leg, e_D is the total error in departure, e_L is the total error in latitude, C_D is the correction in departure applied to any leg, and C_L is the correction in latitude applied to any leg.

Elevation Adjustment

If elevations have been carried through a traverse, they will be adjusted when a linear balance (Bowditch or Crandall's rule) is performed. The adjustment for each leg will be proportionate to its length:

$$\frac{\text{Correction in Elevation}}{\text{Length of Leg}} = \frac{\text{Total Error in Elevation}}{\text{Total Traverse Length}}$$

Traverse Input and Adjustment

Field notes are entered and reduced in the Coordinate Geometry program. The unadjusted coordinates are stored in the coordinate file. When a traverse is adjusted, the starting and ending point numbers must be input, and corrections are made directly to the stored coordinates. Points on a traverse to be balanced must be *consecutive*.

Suggestion: Before adjusting a traverse, make a copy of the unadjusted coordinates using the Duplicate Points routine (refer to page 27).

Note: While in the Balance routine, the computer stores intermediate values in the space usually reserved for coordinates.

Balance Routine

Purpose: Distributes the angular and/or linear error in a traverse.

Step	Display	Instructions
1	Duplicat, Balance, v, Ex ■	Press [B] .
2	start, end #s ■	Enter the starting and ending points of the traverse (separated by a comma).
3	angl adjust ■	Enter the total angular adjustment you want applied. If no angular balance is needed, enter 0.
4	working	The angular error is distributed.
5	UNADJUSTED: #nn nnn.nn N #nn nnn.nn E #nn nnn.nn H	The display shows the unadjusted coordinates of the ending point.
6a	true N,E of #nn ■	Enter the correct coordinates of the traverse ending point.
6b	true H ■	If elevations have been stored, enter the correct elevation. If not, press [END LINE] .

Step	Display	Instructions
7	<pre> CORRECTION: #nn nnn.nn N #nn nnn.nn E #nn nnn.nn H working CLOSURE: error nnn.nn 1 in nnn.nn </pre>	<p>The display shows the correction in latitude, departure, and elevation, along with the linear and relative errors.</p>
8	<pre> Bowditch,Crandall,Ex█ </pre>	<p>Press [E] to bypass the linear balance, press [B] to balance using the Bowditch (Compass) rule, or press [C] to balance using Crandall's rule.</p>
9	<pre> working </pre>	<p>Adjustments are made directly to the coordinate file. Afterwards, the routine returns to the menu in step 1.</p>

Rotate Points Routine

Purpose: Transforms a point or block of points to a new orientation by rotation about the origin (0,0).

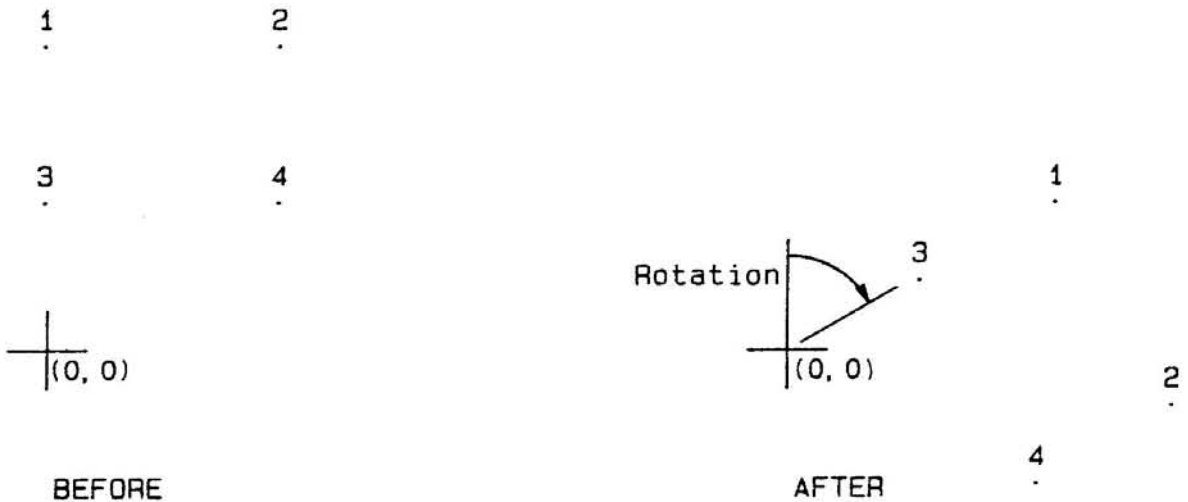

Step	Display	Instructions
1	<pre> Rotat,Trans,Scal,v,Ex█ </pre>	<p>Press [R].</p>
2	<pre> start,end #s █ </pre>	<p>Enter the starting and ending points of the block of coordinates you want rotated (separated by a comma).</p>
3	<pre> rotation angl █ </pre>	<p>The angle may be entered in any of the allowable formats described in section 1, page 15.</p>
4	<pre> working </pre>	<p>The points are rotated about the origin (0,0), then the display returns to the menu in step 1.</p>

Translate Points Routine

Purpose: Transforms a point or block of points to a new location by translation along any or all three axes.

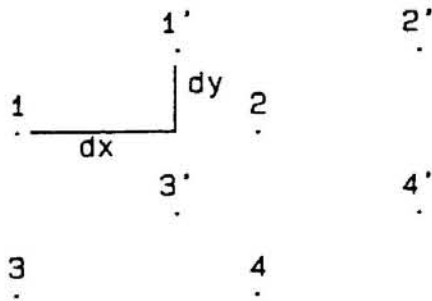

Step	Display	Instructions
1	Rotat, Trans, Scal, v, Ex ■	Press [T] .
2	start, end #s ■	Enter the starting and ending points of the block of coordinates you want translated (separated by a comma).
3	N, E, H ■	N refers to northing, E to easting, and H to elevation. Enter the adjustments you want made to each ordinate. If no adjustment is needed, press [END LINE] .
4	working	The points are translated, then the display returns to the menu in step 1.

Scale Coordinates Routine

Purpose: Applies a multiplier to a point or block of points.

Step	Display	Instructions
1	Rotat, Trans, Scal, v, Ex ■	Press [S] .
2	start, end #s ■	Enter the first and last point numbers of the coordinates you want scaled (separated by a comma).
3	multiplier ■	Enter the scale factor you want applied to all coordinates in the defined block.
4	working	The points are scaled, then the display returns to the menu in step 1.

Section 3

Coordinate Geometry

Contents

Introduction	33
Start Routine	35
Lines Routine	36
Multiple Solutions	37
General Procedure for the Lines Routine	38
Traversing Lines	39
Sideshots	41
Inverse	41
Bearing-Bearing Intersection of Lines	42
Bearing-Distance Intersection of Lines	43
Distance-Bearing Intersection of Lines	44
Distance-Distance Intersection of Lines	46
Curves Routine	47
Curve Traverse	48
Inscribe Curve	49
Radial Stakeout Routine	53
Area/Traverse Computations	54

Introduction

The routines in the Coordinate Geometry (C030) section are based on computing a new point or points given a known starting point, bearing, and distance, or data from which the bearing and distance can be calculated. Also included are staking routines for displaying angular and linear relationships between existing points. The examples in this section are designed to be read and not keyed in.

The following flowchart shows the Cogo menus and how they relate to the main surveying menu.

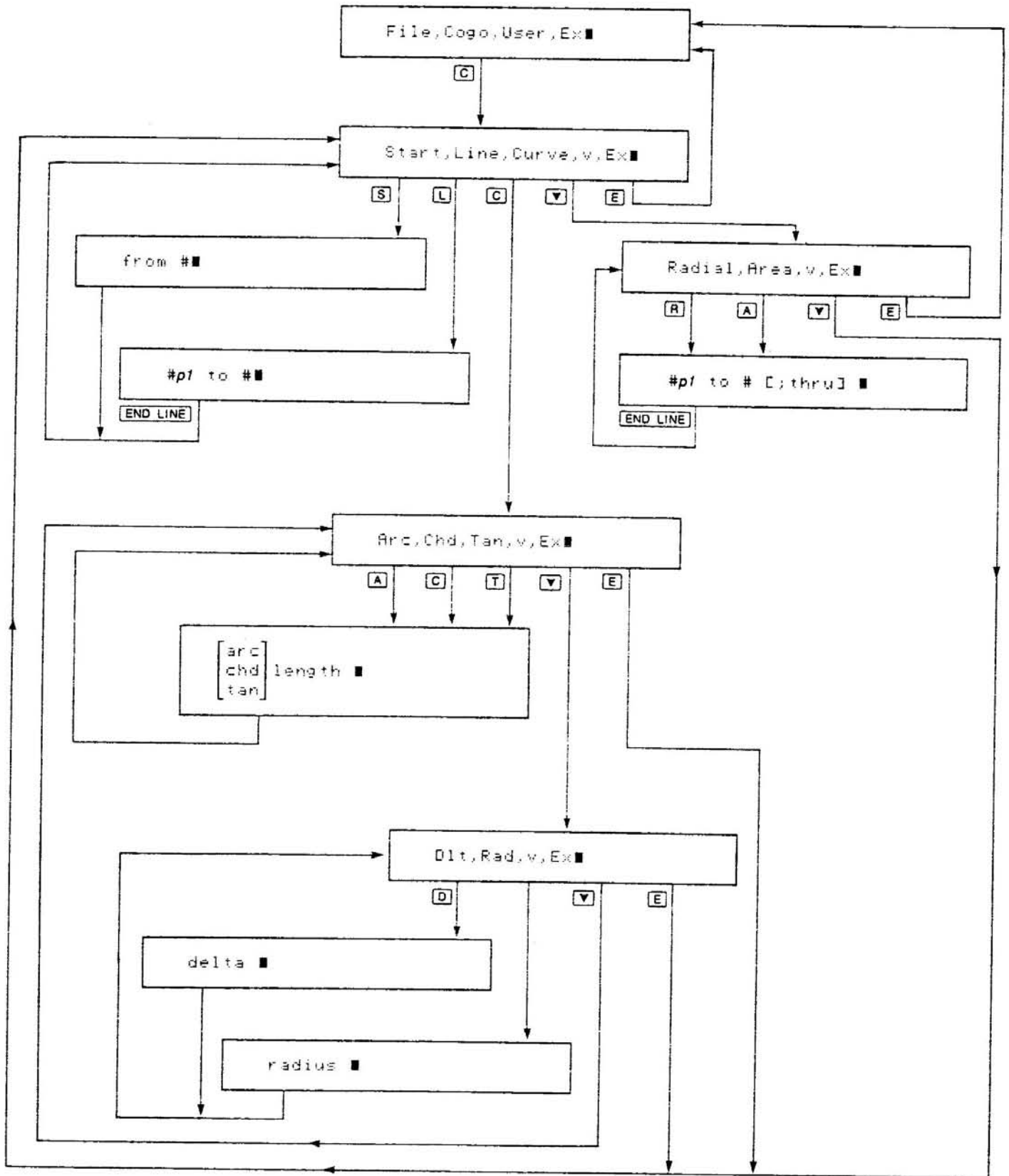

The `COGO` menus contain five routines:

- The Start routine establishes the starting (occupied) point and backsight.
- The Lines routine contains five different solutions for lines: traverse, inverse, bearing-bearing intersection, bearing-distance intersection, and distance-distance intersection. The different solutions are accessed by entering the data that is known, and bypassing unknowns.
- The Curves routine solves for a curve traverse (solves for the point of tangency given the point of curvature, a known radial point, and the arc, chord, central angle, or tangent length) or fits a curve to known tangents.
- The Radial Stakeout routine returns the horizontal angle and distances between stored coordinates for radial staking.
- The Area/Traverse routine operates like the radial stakeout routine, except that the occupied point and backsight are updated at each point on the traverse. This routine computes the curve inverse and the area.

Throughout the `COGO` program two parameters are being constantly referenced and updated. The first is the starting (occupied) point. This point establishes the beginning coordinates for most solutions. The starting point is generally moved with each solution; that is, the point solved in one problem becomes the new starting point for the next. The second parameter is the backsight or reference bearing. Whenever a deflection or angle left or right is used to establish a direction, it is turned off the backsight. The backsight is updated every time the starting point moves.

Start Routine

The Start routine establishes the currently occupied point and backsight. Usually, the starting point is determined from the previous solution. This routine allows you to specify a new point and backsight. Note that you should enter the backsight as the direction *from* the occupied point *toward* the reference.

The Start routine also allows you to select absolute or field angles for subsequent results. Bearings or azimuths will be displayed if you select absolute angles. Field angles are measured off the current backsight, and may be angles right (interior) or deflections right. The Start routine begins running automatically when you select the `COGO` program.

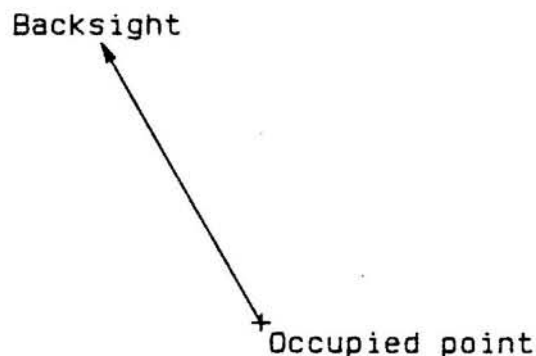

Step	Display	Instructions
1	Start, Line, Curve, v, Ex ■	Press [S] . This step is skipped when you enter Cogo from the main menu.
2	from # ■	Enter the currently occupied point number. If you enter a point that has not yet been assigned, the HP-71 will request and then display the coordinates.
3	backsight ■	Enter the backsight bearing, using any allowable format (refer to page 16). If you want to use the previous backsight, just press [END LINE] .
4	b.s. <i>nnn.nn</i>	The backsight is displayed.
5	angle Abs, Field ■	Press [A] to have the output in absolute angles (bearings or azimuths). Press [F] to have the output in field angles (angles right or deflections right) as specified in section 1.
6		The HP-71 displays the starting coordinates and the backsight, then returns to step 1.

Lines Routine

Five different solutions are part of the Lines routine of the **Cogo** program. These five solutions are:

Traverse and Sideshot. Calculates the coordinates of a new point given the bearing and distance from a known point.

Inverse. Finds the bearing and distance between two known points.

Bearing-Bearing Intersection. Finds the intersection of two lines.

Bearing-Distance Intersection. Finds the intersections of a line and a circle.

Distance-Distance Intersection. Finds the intersections of two circles.

The various solutions are accessed by supplying the computer with the data values you do know, and ignoring those values you don't know (just press **[END LINE]** when the program prompts for that information). There are six possible inputs, although no more than four are needed for any given problem. The program stops requesting data as soon as it has enough information.

The chart on the next page shows the possible types of solutions and the information required for each solution. An X means the data must be entered, while a 0 means no data need be entered. Assume that the occupied point, $p1$, is established by the previous solution or by the Start routine. The second known point is $p2$, and the solution point is p .

	<i>p</i>	Horiz. Angle, <i>p1 to p</i>	Distance, <i>p1 to p</i>	<i>p2</i>	Horiz. Angle, <i>p2 to p</i>	Distance, <i>p2 to p</i>
Traverse	X	X	X			
Sideshot	-X	X	X			
Inverse	X	0	0			
Bearing-Bearing	X	X	0	X	X	
Bearing-Distance	X[X]	X	0	X	0	X
Distance-Bearing	X[X]	0	X	X	X	
Distance-Distance	X[X]	0	X	X	0	X

Multiple Solutions

Some Cogo intersection problems have two possible solutions. The choice for solving one or both points is made when the solve point number is entered. To solve and store both points, two different point numbers must be entered, separated by a semicolon.

To avoid calculating one of the points, the point number must be zero or else not given. The following examples illustrate this.

5;0

or

5

Only the first solution is calculated. Point #5 is assigned the solved coordinates.

0;8

or

;8

Only the second solution is calculated, and the coordinates are assigned to point #8.

11;12

Both points are solved. The first solution is assigned to point #11, and the second to point #12.

General Procedure for the Lines Routine

The general procedure for the Lines routine is:

Step	Display	Instructions
1	Start, Line, Curve, v, Ex ■	Press [L] .
2	#p1 to # ■	p1 represents the currently occupied point. Press [END LINE] with no entry to return to step 1. or Enter the point number(s) of the point(s) to be solved. or To solve the point without changing the current set-up (location and backsight), enter the number of the point to be solved as a negative value. or Enter a + to assign the next consecutive point number (incremented one from the occupied point number).
3	hrz[;vrt] angl p1*p ■	Enter the known direction from the starting point to the point to be solved. This may be entered as a direction (bearing, north or south azimuth) or an angle turned from the current backsight. Press [END LINE] if the direction is unknown.
4	hrz[;vrt] dst p1*p2 ■	Enter the known distance from the starting point to the solve point. If unknown, press [END LINE] .
5		If the program has enough information at this point, the results are displayed and execution continues at step 2. Otherwise, it continues with step 6.
6	2nd known # ■	Enter the point number of the second known point (p2). If p2 is not assigned, you must enter the coordinates at this time.
7	hrz angl p2*p ■	Enter the known bearing from the second point to the solve point and proceed to step 9. If the bearing is unknown, press [END LINE] and proceed to step 8.
8	distance p2*p ■	Enter the known distance from the second point to the solve point.
9		The results are displayed, and execution continues with step 2.

Traversing Lines

Given: the known starting coordinates of a point, a direction, and the distance.

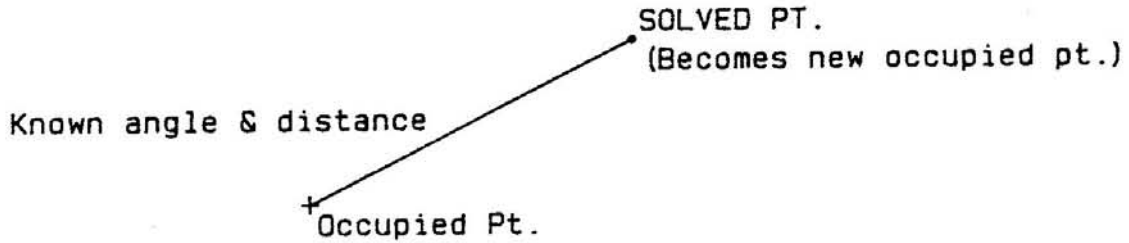

Solve: the coordinates of a new point.

To facilitate field note reduction, the traverse solution also includes slope reduction and vertical control.

Slope Distances. When the prompt appears for the horizontal angle (step 2 on page 40), a vertical angle can also be entered. If it is entered, the distance input in step 3a will be assumed to be a slope distance and will be reduced to horizontal and vertical components. Either a vertical or a zenith angle can be input. The program will then calculate the angle to within 45° of horizontal.

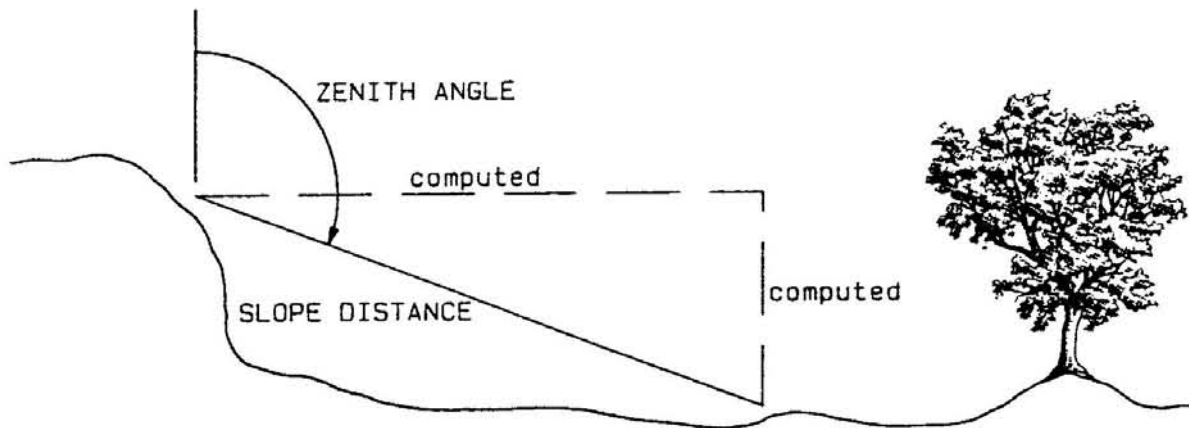

Vertical Distances. Vertical distances are computed when a slope distance and a zenith angle are entered. Alternatively, the vertical distance can be input along with the horizontal distance.

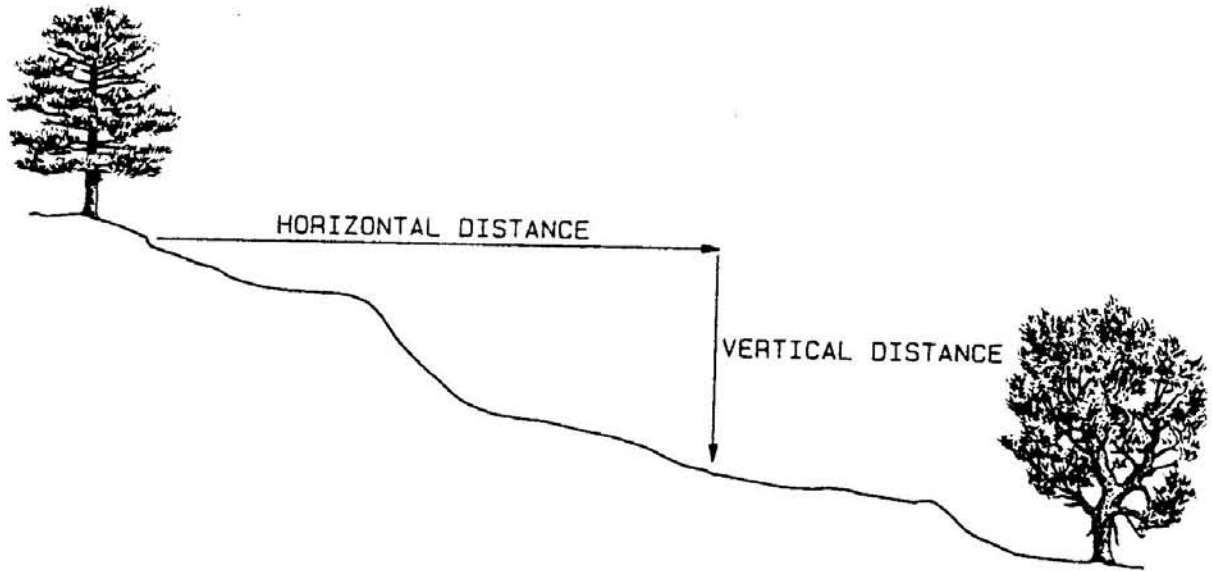

Elevations. If the occupied point has an assigned elevation, a new elevation will be stored with the solved point whenever a vertical distance is entered (whether this distance is entered directly or is computed from a slope distance and a zenith or vertical angle).

Step	Display	Instructions
1	#p1 to #■	Enter the number of the point to be solved. (p1 is the currently occupied point.) Press END LINE to return to the Start menu.
2	hrz[;vrt] angl p1*p ■	Enter the direction in any allowable form (bearing, azimuth, or field angle). Optionally, a vertical or zenith angle can be entered, separated from the first entry by a semicolon.
3a	hrz[;vrt] dst p1*p ■	Enter the horizontal distance to the traverse, which can be followed by a semicolon and a vertical distance.
3b	slope dst p1*p ■	If a zenith or vertical angle was used in step 2, enter the slope distance.
4		The direction, distance, and coordinates of the solved point are displayed. The solved point becomes the new starting point, and the new backsight is to the old occupied point. Execution continues with step 1.

Sideshots

The Sideshot solution is identical to the Traverse solution, except that the occupied point and backsight are not changed.

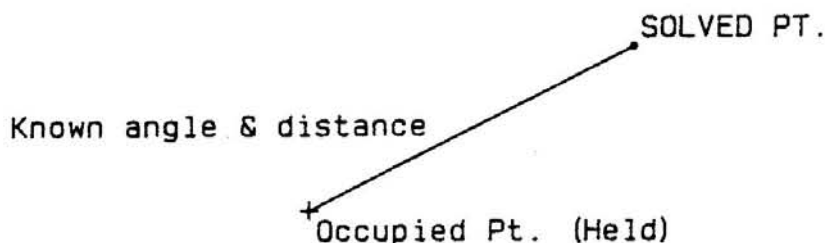

Step	Display	Instructions
1	#p1 to #	Enter the <i>negative</i> point number of the point to be solved. Press END LINE to exit this routine.
2	hrz[]vrt[] angl p1*p	Enter the direction in any allowable form (bearing, azimuth, or field angle). Optionally, a vertical or zenith angle can be entered, separated from the first entry by a semicolon.
3a	hrz[]vrt[] dst p1*p	Enter the horizontal distance to traverse, which can be followed by a semicolon and vertical distance.
3b	slope dst p1*p	If a zenith or vertical angle was entered in step 2, enter the slope distance.
4		The direction, distance, and coordinates are displayed. The occupied point and backsight are not changed. Execution continues with step 1.

Inverse

Given: two known points.

Solve: the direction and distance between them.

Step	Display	Instructions
1	#p1 to #	Enter the number of the second known point. Press END LINE to return to the Start menu.
2	hrz[]vrt[] angl p1*p	Press END LINE as this is unknown.
3	hrz[]vrt[] dst p1*p	Press END LINE as this is unknown.
4		The angle, distance, and coordinates are displayed. Execution continues with step 1.

Bearing-Bearing Intersection of Lines

Given: two known points and the bearings from each.

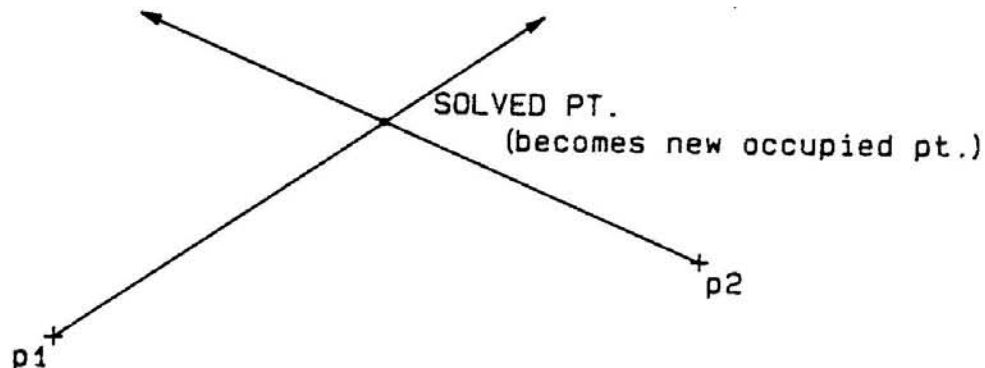

Solve: coordinates of the point of intersection.

Step	Display	Instructions
1	#p1 to #■	Enter the point number of the point to be solved. To maintain the current occupied point and backsight, enter a negative number. Press END LINE to return to the Start menu.
2	hrz[;wrt] angl p1*p ■	Enter the direction or angle turned.
3	hrz[;wrt] dst p1*p ■	Press END LINE as this is unknown.
4	2nd known #■	Enter the number of the second known point. The coordinates are displayed.
5	hrz angl p2*p ■	Enter the direction from the second point to the unknown point.
6		The directions and distances from both known points to the solved point are displayed. The new coordinates are also displayed. If the point number of the solved point was entered as a positive number, it becomes the new occupied point, and the new backsight is toward the second known point.

Bearing-Distance Intersection of Lines

Given: two known points, a bearing from the first, and the distance from the second.

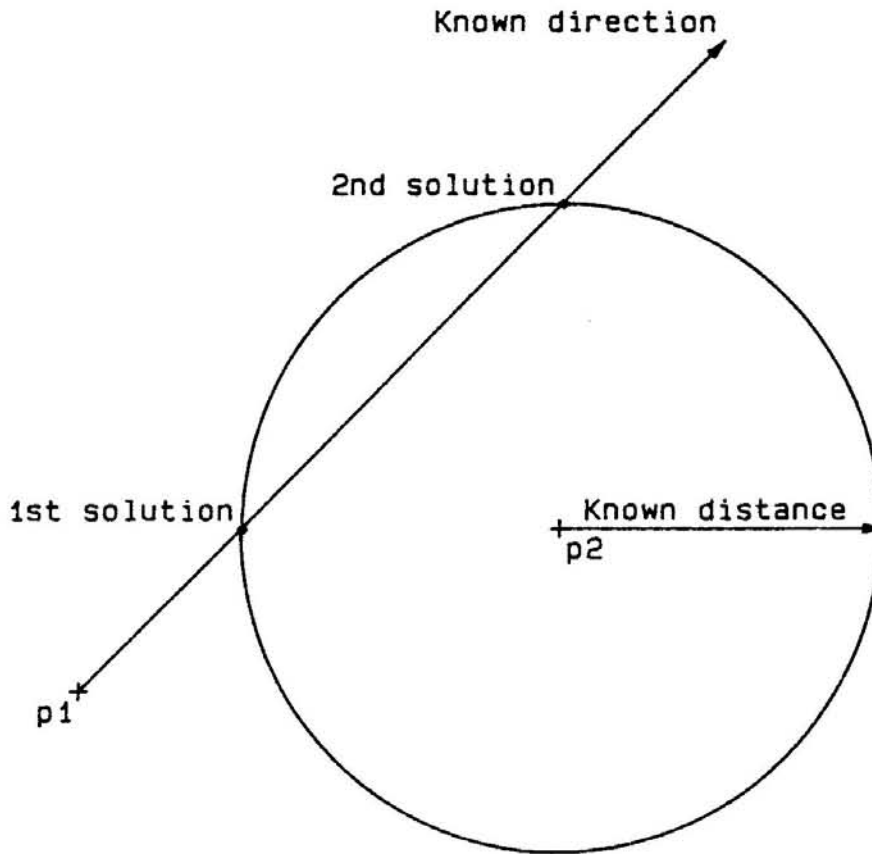

Solve: the coordinates of the points of intersection (there are two possible solutions).

Step Display

1 #p1 to #

2 hrz[;wrt] angl p1#p

Instructions

$p1$ is the number of the currently occupied point. Enter the point number(s) of the point(s) to be solved. If only the first solution is required, enter a single point number. For both points, enter two different point numbers separated by ;. To obtain only the second solution, precede the solve point number by ; or @;. Press **END LINE** to exit this routine.

Enter the direction from the first known point to the solve point(s).

3 hrz [; vrt] dst p1*p ■

Since the distance from the first point is unknown, skip this entry (press **END LINE**).

4 2nd known # ■

Enter the point number of the second known point (p2). The coordinates will be displayed.

5 hrz angl p2*p ■

Since the second direction is unknown, skip this entry (press **END LINE**).

6 distance p2*p ■

Enter the distance from the second known point to the solve point.

7

Directions, distances, and solved coordinates are displayed. Unless entered as a negative value, the solve point becomes the new occupied point, with a backsight to the second known point.

Distance-Bearing Intersection of Lines

Given: two known points, the distance from the first point, and a bearing from the second.

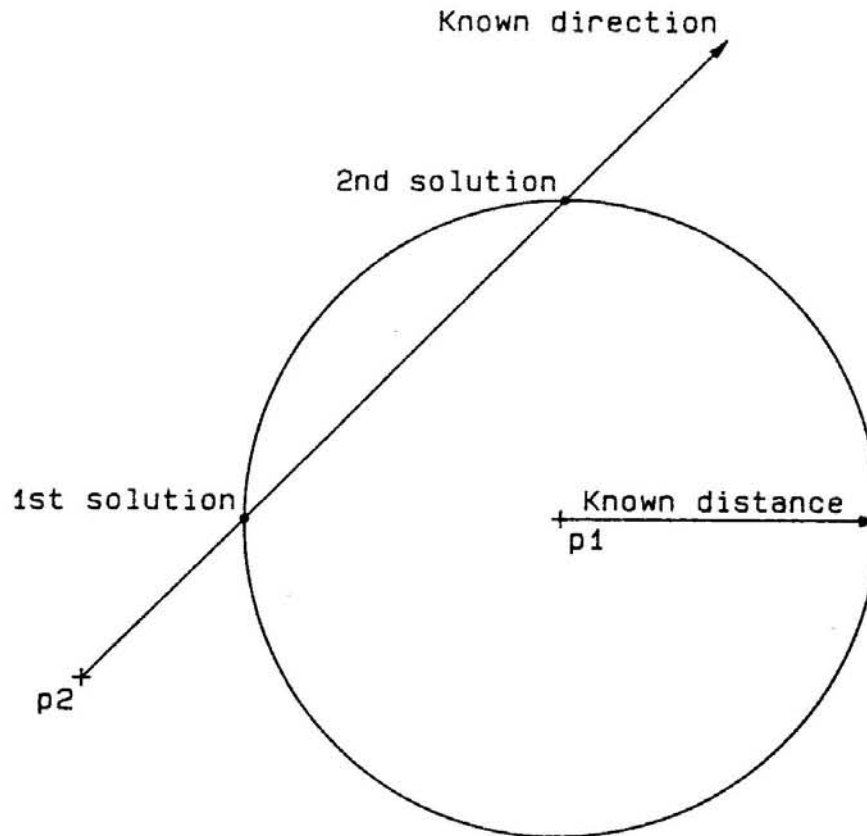

Solve: the coordinates of the points of intersection (there are two possible solutions).

This routine is identical to the Bearing-Distance solution, except that the order of input is reversed.

Step Display

1 #p1 to #■

Instructions

p1 is the number of the currently occupied point. Enter the point number(s) of the point(s) to be solved. If only the first solution is required, enter a single point number. For both points, enter two different point numbers separated by ;. To obtain only the second solution, precede the solve point number by ; or Ⓢ. Press **END LINE** to exit this routine.

2 hrz[;vrt] angl *p1*p* ■

Since the direction from the first input is unknown, skip this entry (press **END LINE**).

3 hrz[;vrt] dst *p1*p* ■

Enter the distance between the first known point and the solve point.

4 2nd known #■

Enter the point number of the second known point. The coordinates are displayed.

5 hrz angl *p1*p* ■

Enter the direction or angle turned to the solve point from the second known point.

6

The results are calculated and displayed. If entered as a positive value, the solve point becomes the new occupied point, and the backsight is to the second known point.

Distance-Distance Intersection of Lines

Given: two known points and the distance from each to a third point.

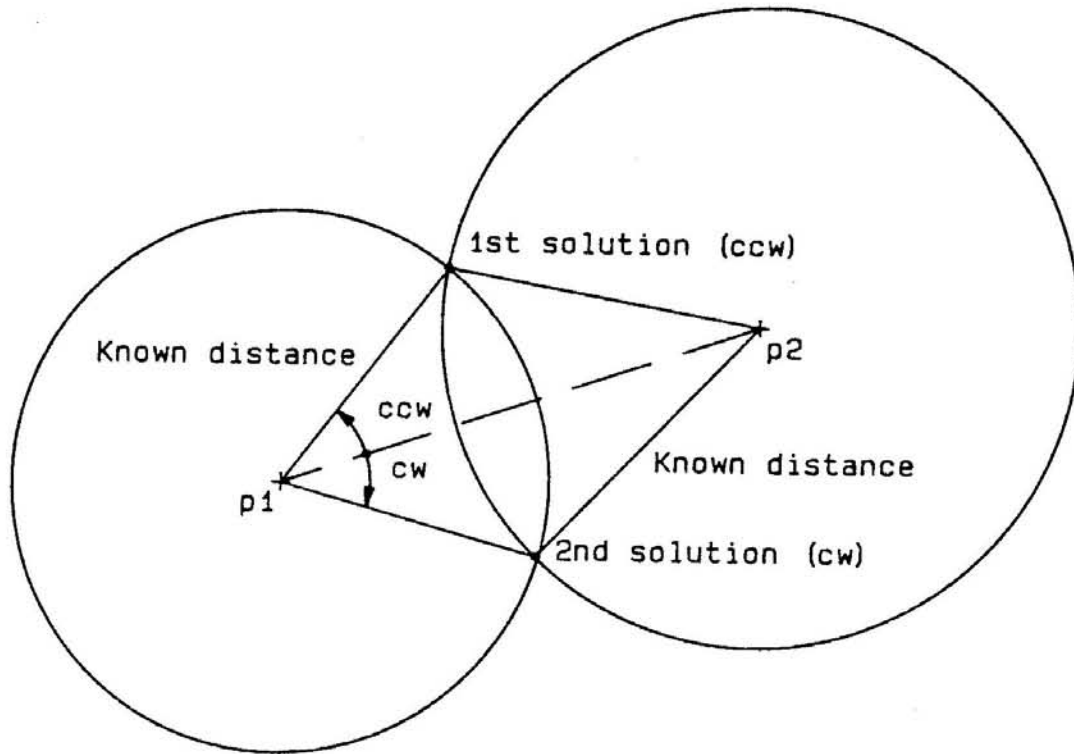

Solve: the coordinates of the third point (there are two possible solutions).

Step Display

- 1 #p1 to #■
- 2 hrz[;vrt] angl p1*p ■
- 3 hrz[;vrt] dst p1*p ■

Instructions

$p1$ is the number of the currently occupied point. Enter the point number(s) of the point(s) to be solved. If only the first solution is required, enter a single point number. For both points, enter two different point numbers separated by ;. To obtain only the second solution, precede the solve point number by ; or @;. Press **END LINE** to exit this routine.

Since the bearing is unknown, press **END LINE** without entering data.

Enter the known distance from the first point.

- 4 2nd known # ■ Enter the second known point number. The coordinates are displayed.
- 5 hrz angl $p2*p$ ■ Since the bearing is not known, just press **END LINE**.
- 6 distance $p2*p$ ■ Enter the distance from the second known point to the solve point.
- 7 The HP-71 now displays the angles, distances, and solved coordinates and returns to step 1.

Curves Routine

The Curves routine of **Logo** solves two types of problems:

Curve Traverse. Solves for the point of tangency (PT) from a known point of curvature (PC) and a known radial point (RP), given the arc, chord, tangent, or delta (central angle).

Inscribe Curve. Solves for the PC , PT , and RP , given a known radius and two known tangents (straight or curved).

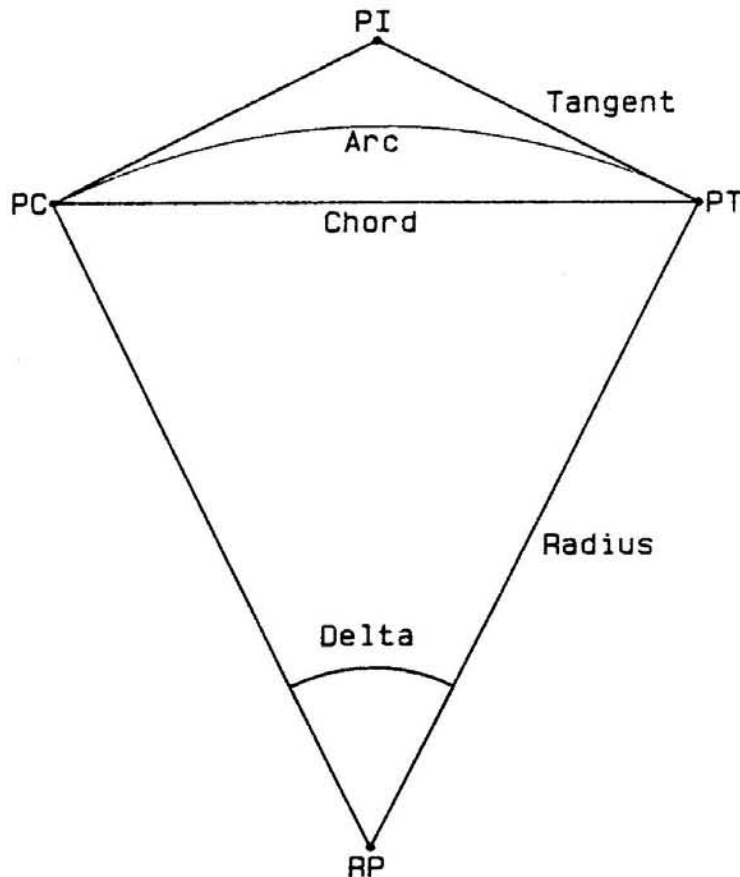

Call the Curves routine from the Cogo menu:

Start, Line, Curve, v, Ex■

Press **C** for the Curves routine. (**V** displays the Radial, Area, v, Ex■ menu, while **E** returns the main File, Cogo, User, Ex■ menu.)

Curve Traverse

The Curve Traverse routine will solve the point of tangency (*PT*), given the point of curvature (*PC*), radial point (*RP*), and the arc, chord, tangent, or delta (central angle) of a curve.

The *PC* is the currently occupied point. Use the Start routine to change the *PC* if necessary.

Curve Traverse—Arc Length.

Step	Display	Instructions
1	Arc, Chd, Tan, v, Ex■	Press A .
2	arc length ■	Enter the arc length. If the curve is counter-clockwise, enter a negative value.
3	rp ■	Enter the point number of the known radial point.
4	#p1 to #■	Enter the point number to be assigned to the <i>PT</i> (<i>p1</i> is the <i>PC</i>).
5		The HP-71 now calculates the <i>PT</i> and displays the curve data. If the point number for the <i>PT</i> was positive, the <i>PT</i> becomes the new starting point, and the backsight is toward the radial point. The routine returns to step 1.

Curve Traverse—Chord Length.

Step	Display	Instructions
1	Arc, Chd, Tan, v, Ex■	Press C .
2	chd length ■	Enter the chord length. If the curve is counter-clockwise, enter a negative value.
3	rp ■	Enter the point number of the known radial point.
4	#p1 to #■	Enter the point number for the <i>PT</i> . (<i>p1</i> is the <i>PC</i> .)
5		The routine now calculates the <i>PT</i> and displays the curve data. If the point number for the <i>PT</i> was positive, the <i>PT</i> becomes the new starting point, and the backsight is toward the radial point. The routine returns to step 1.

Curve Traverse—Chord Length.

Step	Display	Instructions
1	Arc, Chd, Tan, v, Ex ■	Press <input type="button" value="T"/> .
2	tan length ■	Enter the tangent length. If the curve is counter-clockwise, enter a negative value.
3	rp ■	Enter the point number of the known radial point.
4	#p1 to # ■	Enter the point number for the <i>PT</i> . (<i>p1</i> is the <i>PC</i> .)
5		The routine now calculates the <i>PT</i> and displays the curve data. If the point number for the <i>PT</i> was positive, the <i>PT</i> becomes the new starting point, and the backsight is toward the radial point. The routine returns to step 1.

Curve Traverse—Central Angle (Delta).

Step	Display	Instructions
1a	Arc, Chd, Tan, v, Ex ■	Press <input type="button" value="v"/> to get to the next menu in the series.
1b	Dlt, Rad, v, Ex ■	Press <input type="button" value="D"/> .
2	delta ■	Enter the central angle. If the curve is counter-clockwise, enter a negative value.
3	rp ■	Enter the point number of the known radial point.
4	#p1 to # ■	Enter the point number for the <i>PT</i> . (<i>p1</i> is the <i>PC</i> .)
5		The routine now calculates the <i>PT</i> and displays the curve data. If the point number for the <i>PT</i> was positive, the <i>PT</i> becomes the new starting point, and the backsight is toward the radial point. The routine returns to step 1.

Inscribe Curve

The Inscribe Curve routine will locate three points (the *PC*, *PT*, and *RP*) defining a curve, given the curve radius and the tangent lines. Straight tangents are defined by a known point and bearing, and curved tangents are defined by a known radial point and radius.

Since there are several solutions in any given case, a few rules must be observed when entering data. The first is that data must be entered as it occurs in a clockwise direction. In other words, the angle from the *PC* to the *PT* must be clockwise.

If one of the tangents is a curve, you must indicate whether it turns clockwise or counter-clockwise. The examples in the following table illustrate these rules.

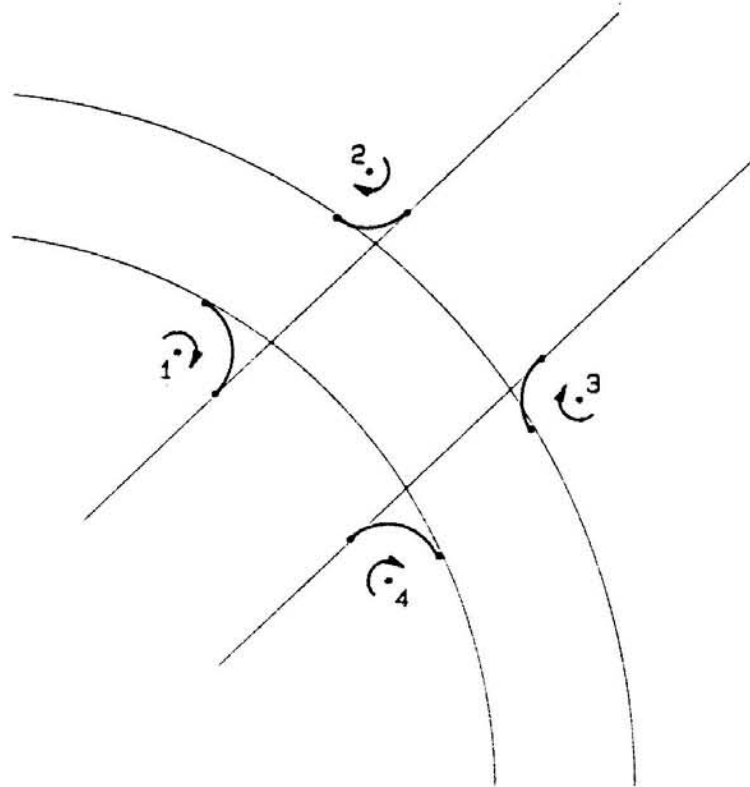

Curve #	Tangent In	Tangent Out
1	Clockwise curve	SW bearing
2	SW bearing	Counter-clockwise curve
3	Counter-clockwise curve	NE bearing
4	NE bearing	Clockwise curve

Inscribe Curve—Straight/Straight.

Step	Display	Instructions
1a	Arc, Chd, Tan, v, Ex ■	Press <input type="checkbox"/> to get to the next menu.
1b	Dlt, Rad, v, Ex ■	Press <input type="checkbox"/> .
2	radius ■	Enter the radius of the curve to be solved.
3	# on tan in (-rp) ■	Enter any point that falls on the line tangent to the curve at the <i>PC</i> .
4	angl in ■	Enter the direction of the line from the <i>PC</i> to the curve <i>PI</i> (Point of Intersection).
5	# on tan out (-rp) ■	Enter any point that falls on the line tangent to the curve at the <i>PT</i> .
6	angl out ■	Enter the direction of the line from the curve <i>PI</i> to the <i>PT</i> .
7	solve # ■	Enter the first of three consecutive point numbers to be assigned to the solved coordinates.
8		The routine solves the <i>PC</i> , <i>PT</i> , and <i>RP</i> of the curve, and displays the curve data. If the number of the solved point was entered as a positive value, the <i>PT</i> becomes the new starting point with a backsight to the radial point.

Inscribe Curve—Straight/Curved.

Step	Display	Instructions
1a	Arc, Chd, Tan, v, Ex ■	Press <input type="checkbox"/> to get to the next menu.
1b	Dlt, Rad, v, Ex ■	Press <input type="checkbox"/> .
2	radius ■	Enter the radius of the curve to be solved.
3	# on tan in (-rp) ■	Enter the radial point of the tangent curve as a negative number.
4	radius in (-ccw) ■	Enter the radius of the tangent curve. If the curve turns counter-clockwise, enter a negative value.
5	# on tan out (-rp) ■	Enter any point that falls on the line tangent to the curve at the <i>PT</i> .

Step Display

6 angl out ■

7 solve #■

8

Instructions

Enter the direction of the line from the curve *PI* to the *PT*.

Enter the first of three point numbers to assign to the solved coordinates.

The routine solves the *PC*, *PT*, and *RP* of the curve, and displays the curve data. If the number of the solved point was entered as a positive value, the *PT* becomes the new starting point with a backsight to the radial point.

Inscribe Curve—Curved/Curved.**Step Display**

1a Arc, Chd, Tan, w, Ex■

1b Dlt, Rad, w, Ex■

2 radius ■

3 # on tan in (-rp) ■

4 radius in (-ccw) ■

5 # on tan out (-rp) ■

6 radius out (-ccw) ■

7 solve #■

8

Instructions

Press to get to the next menu.

Press .

Enter the radius of the curve to be inscribed.

Enter the radial point of the tangent curve as a negative number.

Enter the radius of the tangent curve. If the curve turns counter-clockwise as it approaches the inscribed curve, enter a negative number.

Enter the radial point of the second tangent curve as a negative number.

Enter the radius of the second tangent curve. If it turns counter-clockwise as it exits the inscribed curve, enter a negative value.

Enter the first of three point numbers to assign to the solved coordinates.

The routine solves the *PC*, *PT*, and *RP* of the curve, and displays the curve data. If the number of the solved point was entered as a positive value, the *PT* becomes the new starting point with a backsight to the radial point.

Radial Stakeout Routine

The Radial Stakeout routine displays the angles and distances from a fixed occupied point to a series of existing points. The occupied point and backsight are selected in the Start routine or determined by the previous solution.

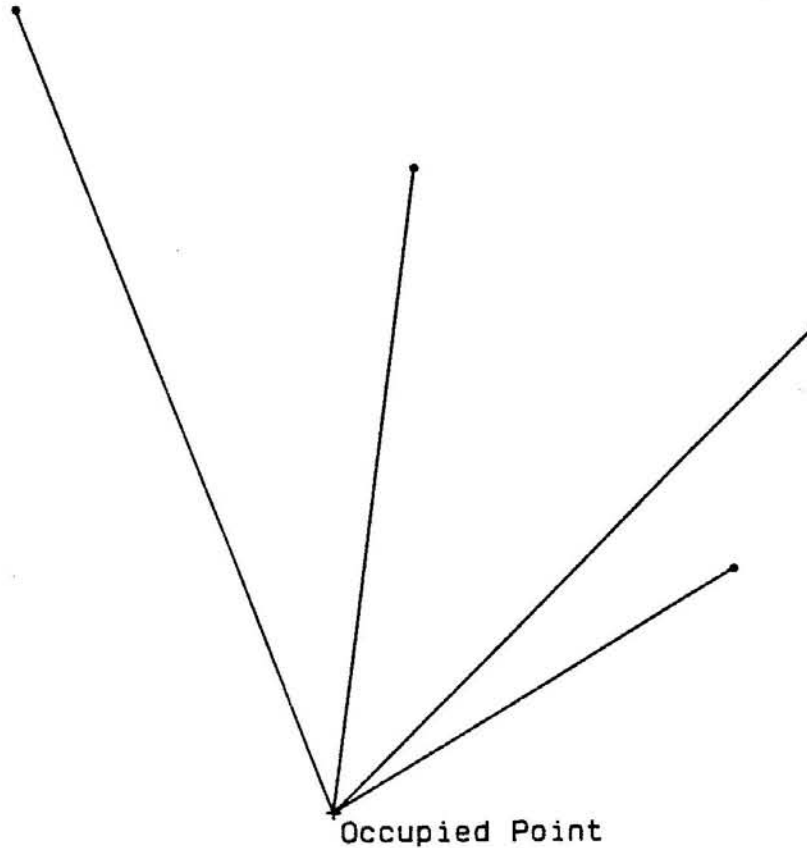

Step	Display	Instructions
1	Start, Line, Curve, v, Ex ■	Press <input type="checkbox"/> to get to the next menu.
2	Radial, Area, v, Ex ■	Press <input type="checkbox"/> .
3	#p1 to # [;thru] ■	Enter a single point to be staked. If you have a series of points to be staked, enter the first and last points, separated by a semicolon. If you want to exit the Radial Stakeout routine, just press <input type="checkbox"/> to return to step 1.
4		After you make your entries, the routine displays the angles and distances between the points, and then returns to step 2.

Area/Traverse Computations

The Area/Traverse routine is similar to the Radial Stakeout routine, except that after inverting to a point, that point becomes the new occupied point, and the backsight is toward the old occupied point. This program can be used to:

- Calculate the area within a defined boundary.
- Inverse lines and curves.
- Display a traverse after adjustments are made.

In every case, a path is defined by entering a sequence of point numbers. Curves are indicated by entering the radial point as a negative number, after which the computer requests the point of tangency. Curves are always assumed to be less than 180° . If a curve is greater than 180° , it must be broken into two parts.

For each segment, the program displays the coordinates, point numbers, angles, and distances (plus curve information, where applicable). The area is displayed when the routine is exited (by pressing **END LINE** with no entry at step 3). The calculated area will be meaningful only if you return to the starting point.

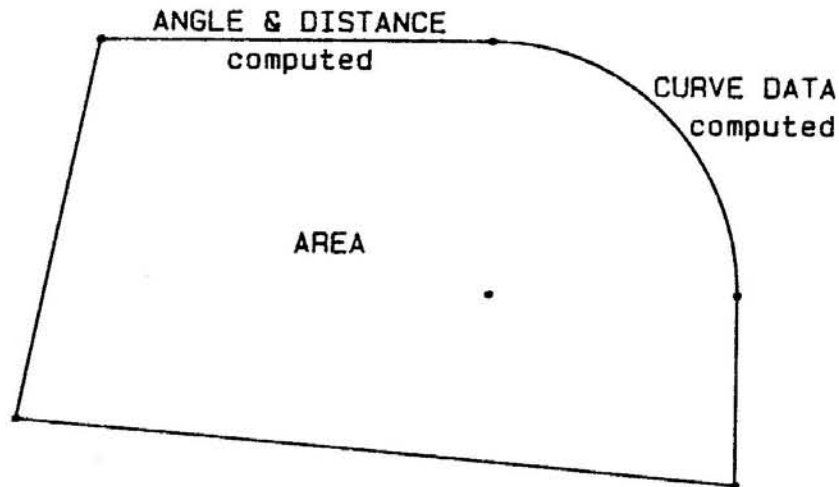

Step	Display	Instructions
1	Radial, Area, v, Ex ■	Press A .
2a	#p1 to # [;thru] ■	For straight segments, enter the next point on the line, <i>or</i> enter the first and last points of a series of points, separated by a semicolon. The inverse data will be displayed, and the last point becomes the occupied point. (Pressing END LINE with no input will get you back to the menu in step 1.)
2b	#p1 to # [;thru] ■	For curved segments, enter the radial point of the curve as a negative number. (<i>p1</i> is the point of curvature, or <i>PC</i> .)
2c	#p1 to # [;thru] ■	To obtain a valid area and then exit the routine, you must first inverse back to the first point of the boundary. Then press END LINE with no entry at this step. The area will be displayed in square feet and acres, and the HP-71 returns to step 1, above.
3	point # ■	Enter the point of tangency. The curve data is displayed, and the point of tangency becomes the new occupied point.

Note: If the computed radii differ by more than 1%, the computer will beep and display radii unequal. It will then return to step 2, with the occupied point unchanged.

Section 4

Examples

Contents

Introduction	57
Example 1: File Creation and Coordinate Storage	58
Creating the Coordinate File	58
Assigning Points #1 and #2	60
Example 2: Field Traverse	61
Establishing the Occupied Point and Backsight	62
Entering the Traverse	63
Closing on the Starting Point	65
Example 3: Duplicate Points and Balance Traverse	66
Duplicate Points	67
Balance Traverse	68
Example 4: Display Traverse and Compute Area	69
Example 5: Solve Roadway Center Line and Curb Line	72
Solving Roadway Center Line	74
Solving the Curb Line	75
Solving the Cul-de-Sac Returns	76
Example 6: Subdivision	81
Lot 1	82
Lot 2	83
Lot 3	85
Lot 4	87
Lot 5	88
Lots 6 and 7	91
Example 7: Lot Summary	92
Example 8: Radial Stakeout	98

Introduction

This section contains eight examples for you to work through using the Surveying Pac. They are designed for you to work through in the order that they occur. The examples build on each other so it's best to start at the beginning and work through all the examples at one time. You start by establishing a coordinate file. Then you solve five common problems using the Surveying Pac's integrated subprograms and routines.

Working through these examples should be well worth the hour or so that you spend. When you are done, you should have a good understanding of how to use the programs and routines as well as an understanding of the practical potential of the Surveying Pac.

Example 1: File Creation and Coordinate Storage

Purpose: To set up a coordinate file and store the coordinates that will serve as the reference points of a traverse.

The 8 example surveying problems require approximately 40 points. Follow the keystrokes to create a coordinate file named DEMO that holds 50 points. Directions should be output as bearings, and field angles should be deflections. Use degrees for angular units. Specify the output to have two decimal places for coordinates and distances, and zero places for angles (seconds).

After the file has been created, store point #1 with coordinates N 1600, E 4150, (no elevation) and point #2 with coordinates N 1735.68, E 7716.40, and H 506.8 (elevation).

Creating the Coordinate File

Input/Result

```
>
```

```
RUN SURVEY [END LINE]
```

Execute the surveying program, SURVEY.

```
file name █
```

```
DEMO [END LINE]
```

Name the coordinate file DEMO.

```
COORD FILE: DEMO
size (### max) █
```

```
50 [END LINE]
```

Allocate room for 50 points.

```
abs angl Brg, Naz, Saz █
```

Input/Result**B**

```
field angl Defl, Angl■
```

Specify bearing for output of directions.

D

```
Degrees, Grads■
```

Select deflections for field angle output.

D

```
secs #decs (0-2)■
```

Angular units in degrees.

0

```
coords #decs (0-5)■
```

No fractional seconds will be displayed.

2

```
distances #decs (0-5)■
```

Coordinates will be displayed with 2 decimal places.

2

```
working
```

Distances will be output to the hundredths place.

There will be a short delay while the file is created.

```
File, Cogo, User, Ex■
```

F

```
File Management
Assgn, List, Clear, v, Ex■
```

Select the File Management program.

Assigning Points #1 and #2

Input/Result

A

point #■

Select the Assign routine.

1 END LINE

N,E of #1 ■

Assign point #1.

1600,4150 END LINE

Enter the coordinates of point #1.

H of #1 ■

No elevation is known.

END LINE

```
#1          1600.00 N
#1          4150.00 E
point #■
```

The values are displayed.

+ END LINE

Auto-increment to assign point #2.

N,E of #2 ■

1735.68,7716.4 END LINE

Input the coordinates of point #2.

H of #2 ■

The elevation is known.

506.8 END LINE

The coordinates are displayed.

```
#2          1735.68 N
#2          7716.40 E
#2          506.80 H
point #■
```

Input/Result

END LINE

Press **END LINE** to exit the Assign routine.

```
Assign, List, Clear, v, Ex
```

E

Exit the File Management program.

```
File, Cogo, User, Ex
```

The main menu is displayed.

Example 2: Field Traverse

Purpose: To enter and reduce field notes for the traverse below.

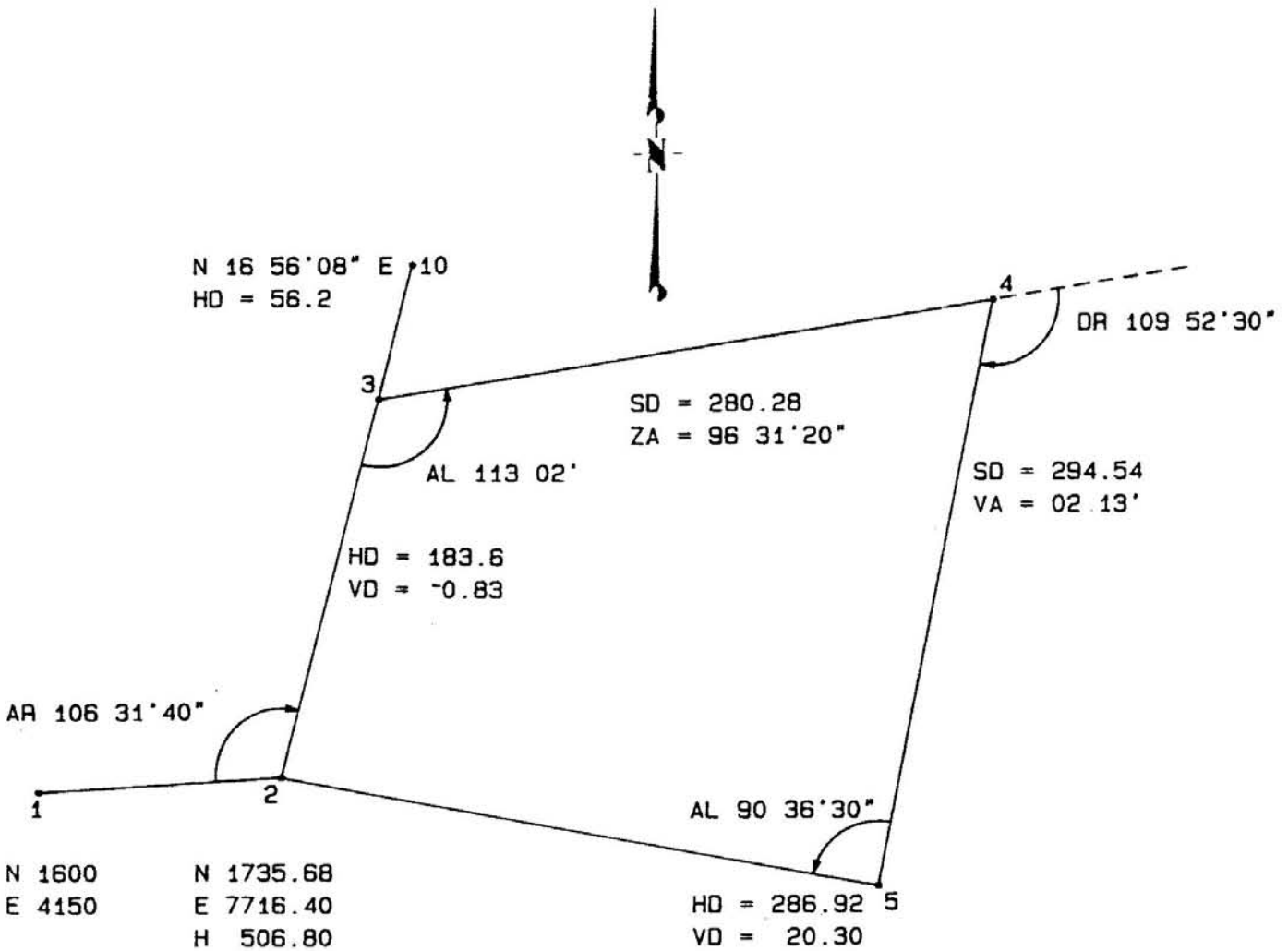

The points stored in example #1 are used as the starting point and backsight for the traverse. The Start routine in Cogo establishes the occupied point and backsight. Each leg is traversed using the traverse option of the Lines routine.

From the last point on the traverse (#5), the closing angle and distance were measured. A temporary point (#6) will be stored to account for any errors in closure (if no errors are present, points #6 and #2 will have the same coordinates).

Establishing the Occupied Point and Backsight

Input/Result

```
File, Cogo, User, Ex■
```

C

Select the Coordinate Geometry program.

```
Coordinate Geometry  
from #■
```

2 END LINE

Point #2 is the occupied point.

```
#2          1735.68 N  
#2          7716.40 E  
#2          506.80 H  
backsight ■
```

The coordinates of point #2 are displayed.

2*1 END LINE

Use a defined direction (from #2 to #1) to establish backsight.

```
b.s.      SW  87 49'17"  
angls Abs,Field■
```

A

Select absolute angle output (directions).

Entering the Traverse

Input/Result

```
Start, Line, Curve, v, Ex ■
```

L

```
#2 to #■
```

3 **END LINE**

```
hrz[;vrt] angl 2#3 ■
```

+106.3140 **END LINE**

```
hrz[;vrt] dst 2#3 ■
```

183.6;-0.83 **END LINE**

```
2-3      NE  14 20'57"
2-3              183.60
#3              1913.55 N
#3              7761.90 E
#3              505.97 H
#3 to #■
```

-10 **END LINE**

```
hrz[;vrt] angl 3#10 ■
```

NE16.5608 **END LINE**

```
hrz[;vrt] dst 3#10 ■
```

Select the Lines routine.

Angle right from backsight 106°31'40".

Horizontal distance = 183.6; vertical distance = -0.83.

Bearing, distance, and coordinates are displayed.

A negative point number indicates a sideshot.

Bearing NE 16°56'08".

Input/Result56.2 **END LINE**

```

3-10      NE  16 56'08"
3-10                      56.20
#10       1967.32 N
#10       7778.27 E
#10       505.97 H
#3 to #■

```

Horizontal distance = 56.2.

+ **END LINE**

hrz[;vrt] angl 3#4 ■

Use the auto-increment to select point #4.

-113.02;2.13 **END LINE**

Backsight is to point #2. Enter angle left and vertical angle.

slope dst 3#4 ■

294.54 **END LINE**

The slope distance will be reduced to horizontal.

```

3-4      NE  81 18'57"
3-4                      294.32
#4       1957.99 N
#4       8052.85 E
#4       517.36 H
#4 to #■

```

+ **END LINE**

Auto-increment.

hrz[;vrt] angl 4#5 ■

+180+109.5230;96.3120 **END LINE**

Deflection right = 109°52'30"; zenith angle = 96°31'20".

slope dst 4#5 ■

Input/Result

280.28 **END LINE**

4-5	SW	11 11'27"
4-5		278.47
#5		1684.82 N
#5		7998.80 E
#5		485.53 H

Slope distance entry.

Closing on the Starting Point

Input/Result

#5 to #6

+ **END LINE**

hrz[;vrt] angl 5#6

-90.3630 **END LINE**

hrz[;vrt] dst 5#6

286.92;20.5 **END LINE**

5-6	NW	79 25'03"
5-6		286.92
#6		1737.51 N
#6		7716.76 E
#6		506.03 H
#6	to #	

Point #6 holds the unadjusted coordinates of the starting point.

Angle left = 90°36'30".

Horizontal distance = 286.92; vertical distance = 20.5.

Input/Result

END LINE

Press **END LINE** to return to the menu.

```
Start, Line, Curve, v, Ex █
```

E

Exit the Coordinate Geometry program.

```
File, Cogo, User, Ex █
```

The main menu is displayed.

Example 3: Duplicate Points and Balance Traverse

Purpose: To make a duplicate set of the points solved in examples 1 and 2, and balance the traverse according to the Compass rule (Bowditch).

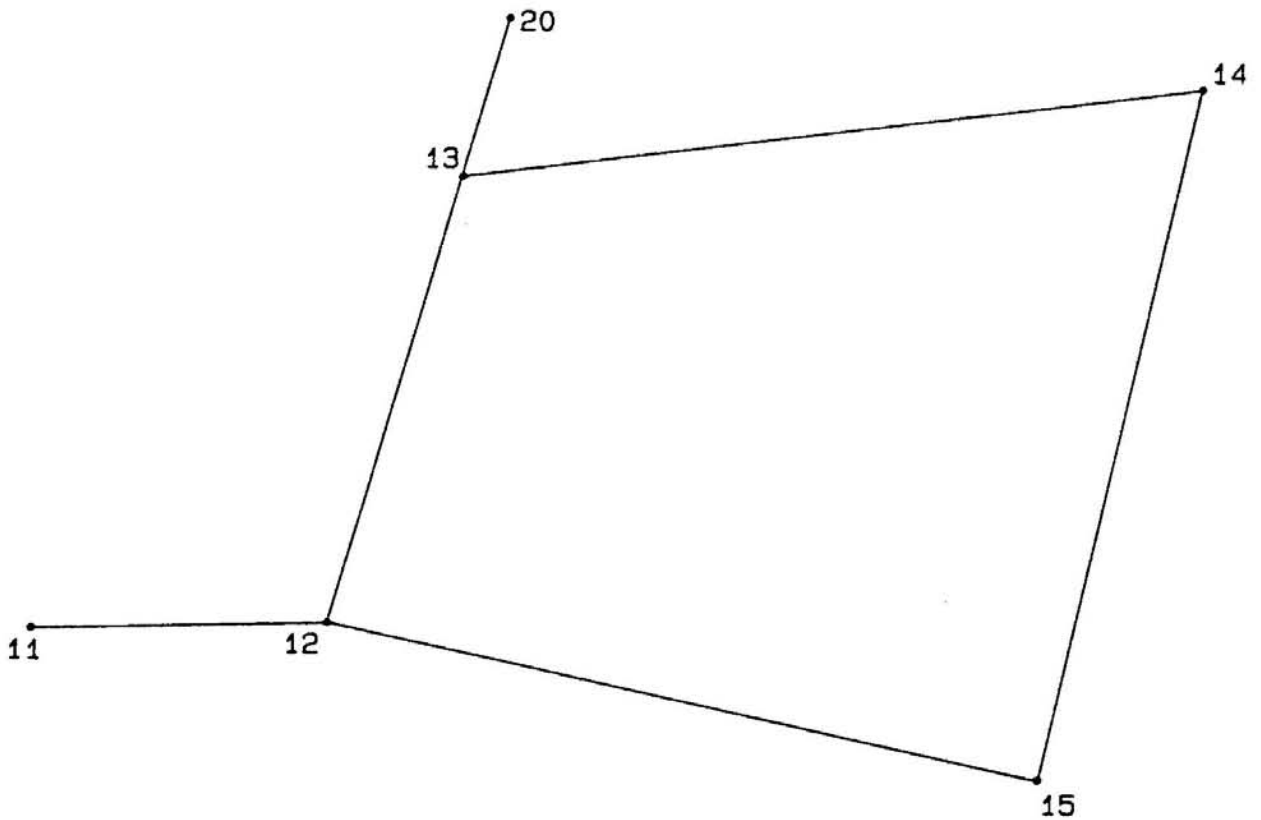

Points 1-10 will be duplicated as points 11-20. The adjustment will be made to the duplicated points.

Duplicate Points

Input/Result

```
File, Cogo, User, Ex■
```

F

```
File Management
Assgn, List, Clear, v, Ex■
```

▼

```
Duplicat, Balance, v, Ex■
```

D

```
start, end #s ■
```

1, 10 END LINE

```
new start #■
```

11 END LINE

```
working
```

```
Duplicat, Balance, v, Ex■
```

Select the File Management program.

Move to the next menu.

Select the Duplicate routine.

Duplicate points 1 thru 10.

Assign point #11 to the first duplicate point.

There is a short delay while the points are copied.

Balance Traverse

Input/Result

Duplicat, Balance, v, Ex ■

B

start, end #s ■

12, 16 **END LINE**

angl adjust ■

0 **END LINE**

```

UNADJUSTED:
#16          1737.51 N
#16          7716.76 E
#16          506.03 H
true N,E of #16 ■

```

1735.68, 7716.4 **END LINE**

true H of #16 ■

506.8 **END LINE**

```

CORRECTION:
#16          -1.83 N
#16          -0.36 E
#16           0.77 H

```

Select the Balance routine.

The main traverse is made up of points 12 thru 16.

No angle balance will be performed.

The unadjusted values of point #16 are displayed.

The true coordinates of #16 should match the coordinates of point #12 (2).

Enter the correct elevation.

The corrections are displayed.

Input/Result

```
working
```

Do not interrupt the program.

```
CLOSURE:
error          1.87
1 in          558.38
Bowditch,Crandall,Ex█
```

The error of closure is displayed.

B

Select a Bowditch rule balance.

```
working
```

```
Duplicat,Balance,v,Ex█
```

When the menu appears the balance is complete.

E

Exit the File Management program.

```
File,Cogo,User,Ex█
```

The main menu is displayed.

Example 4: Display Traverse and Compute Area

Purpose: To display the adjusted traverse showing deflection angles, distances, coordinates, and total area.

The Start routine allows selection of field angles (deflections). The Area/Traverse routine will inverse between the adjusted coordinates and calculate the total enclosed area of the traverse.

Input/Result

```
File,Cogo,User,Ex█
```

Input/Result

C

```
Coordinate Geometry
from #
```

Select the Coordinate Geometry program.

12 **END LINE**

Start from point #12.

```
#12          1735.60 N
#12          7716.40 E
#12          506.80 H
backsight
```

The coordinates are displayed.

12*11 **END LINE**

Use a defined direction to establish the backsight.

```
b.s.      SW  87 49'17"
angls Abs,Field
```

F

Select field angle output. Deflections will be used, according to the specifications established when the file was created.

```
Start,Line,Curve,v,Ex
```

V

Skip to the next menu.

```
Radial,Area,v,Ex
```

A

Select the Area program.

```
#12 to # [;thru]
```

Input/Result13;15 **END LINE**

12-13	DL	73 28'00"
12-13		183.27
#13		1913.23 N
#13		7761.84 E
#13		506.11 H

#12 to #13.

13-14	DR	67 03'27"
13-14		294.14
#14		1957.15 N
#14		8052.68 E
#14		517.72 H

#13 to #14.

14-15	DR	109 46'43"
14-15		278.96
#15		1683.49 N
#15		7998.54 E
#15		486.09 H
#15 to #	[;thru]	■

#14 to #15.

12 **END LINE**

15-12	DR	89 17'21"
15-12		286.93
#12		1735.68 N
#12		7716.40 E
#12		506.80 H
#12 to #	[;thru]	■

#15 to #12.

Return to the starting point #12 to ensure a valid area.

Input/Result

END LINE

Bypass this entry to end input and display the area.

```
sq ft          64839.74
acres          1.49
Radial, Area, v, Ex■
```

Press to access the menu for the Start routine.

```
Start, Line, Curve, v, Ex■
```

Example 5: Solve Roadway Center Line and Curb Line

Purpose: To solve and store points defining the roadway center line and curb using the dimensions shown below.

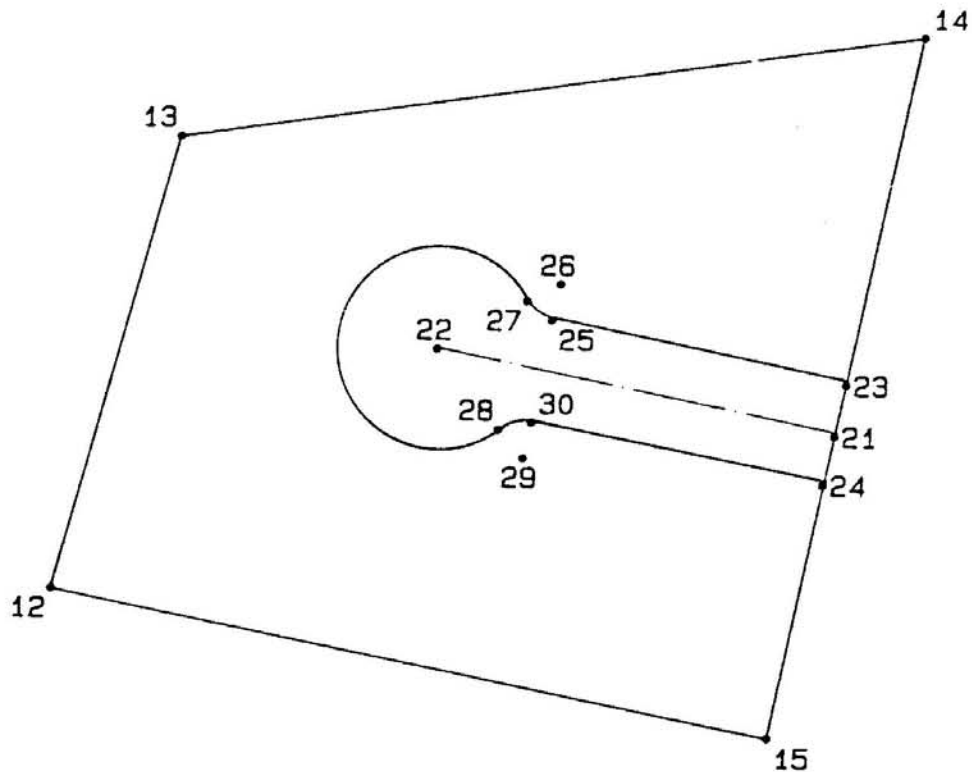

- Center line begins on the east boundary line (14-15) at a point 120 feet from point #15.
- Center line projects perpendicular to line (14-15) for a distance of 160 feet.
- Roadway is 40 feet wide and terminates with a cul-de-sac having a 40 foot radius.
- Curb returns on the cul-de-sac have a 15 foot radius.

Input/Result

```
Start,Line,Curve,v,Ex█
```

[S]

Select the Start routine to reset the occupied point.

```
from #█
```

15 [END LINE]

Select point #15 as the occupied point.

```
#15      1683.49 N
#15      7998.54 E
#15      486.09 H
backsight █
```

The coordinates of point #15 are displayed.

15#12 [END LINE]

Establish the backsight.

```
b.s      NW 79 31'13"
angls Abs,Field█
```

[A]

Select absolute angle output (directions).

```
Start,Line,Curve,v,Ex█
```

[L]

Choose the Lines routine.

Solving Roadway Center Line

Input/Result

```
#15 to #■
```

21 **END LINE**

```
hrz[;vrt] angl 15*21 ■
```

15*14 **END LINE**

```
hrz[;vrt] dst 15*21 ■
```

120 **END LINE**

```
15-21    NE    11 11'27"
15-21                    120.00
#21      -1801.21 N
#21      8021.83 E
#21      486.09 H
#21 to #■
```

-22 **END LINE**

```
hrz[;vrt] angl 21*22 ■
```

+90 **END LINE**

```
hrz[;vrt] dst 21*22 ■
```

Solve point #21.

Point #21 falls on the line from #15 to #14...

at a distance of 120 feet from point #15.

Point #21 is solved, and the values are displayed.

Points #22, #23 and #24 will be set from #21. Use the sideshot designation to maintain the occupied point and backsight.

The center line is perpendicular to line 14-15.

Input/Result

160 END LINE

21-22	NW	78 48'33"
21-22		160.00
#22		1832.26 N
#22		7864.87 E
#22		486.09 H

The center line is 160 feet long.

Solving the Curb Line**Input/Result**

#21 to #■

-23 END LINE

hrz[;vrt] angl 21#23 ■

+180 END LINE

hrz[;vrt] dst 21#23 ■

20 END LINE

21-23	NE	11 11'27"
21-23		20.00
#23		1820.83 N
#23		8025.71 E
#23		486.09 H
#21 to #■		

24 END LINE

hrz[;vrt] angl 21#24 ■

A defined direction of 21#14 could also be entered.

Half the 40 foot roadway width.

Input/Result

+0 END LINE

```
hrz[;vrt] dst 21#24 ■
```

Sight along the backsight.

20 END LINE

21-24	SW	11 11'27"
21-24		20.00
#24		1781.59 N
#24		8017.95 E
#24		486.09 H
#24 to #		

END LINE

Bypass this entry to return to the menu.

Solving the Cul-de-Sac Curb Returns

Input/Result

```
Start, Line, Curve, v, Ex ■
```

Select the Curves routine.

C

```
Arc, Chd, Tan, v, Ex ■
```

Skip to the next menu.

▼

```
Dlt, Rad, v, Ex ■
```

Select the Radius routine. Curb returns are tangent to the cul-de-sac curve and the straight curbs are parallel to the center line.

R

```
radius ■
```

Input/Result15 **END LINE**

on tan in (-rp) ■

23 **END LINE**

angl in ■

21*22 **END LINE**

on tan out (-rp) ■

-22 **END LINE**

radius out (-ccw) ■

-40 **END LINE**

solve #■

25 **END LINE**

#25	1843.65 N
#25	7910.37 E

#27	1851.24 N
#27	7900.08 E

Curb radius = 15 feet.

The tangent going into the curb begins at point #23.

The straight tangent is parallel to the center line.

Center of the cul-de-sac.

Radius of cul-de-sac, entered as a negative since it turns counter-clockwise.

Three points will be solved, beginning with #25.

*PC**PT*

Input/Result

#26		1858.36 N
#26		7913.28 E
delta	AR	50 28'44"
arc		13.22
tan		7.07
chord:		
25-27	NW	53 34'11"
25-27		12.79
radials:		
25-26	NE	11 11'27"
25-26		15.00
26-27	SW	61 40'10"
26-27		15.00

RP

Dlt, Rad, v, Ex ■

R

Solve the second return.

radius ■

15 END LINE

Radius of the curb return.

on tan in (-rp) ■

-22 END LINE

The tangent going into the solved curve is a curve with *RP* #22.

radius in (-ccw) ■

-40 END LINE

The curve turns counter-clockwise, with a 40 foot radius.

on tan out (-rp) ■

Input/Result

24 END LINE

angl out ■

22*21 END LINE

solve #■

28 END LINE

#28	1801.30 N
#28	7890.20 E

Parallel to the center line.

Solve three points beginning with #28.

PC

#30	1804.41 N
#30	7902.61 E

PT

#29	1789.69 N	
#29	7899.70 E	
delta	AR	50 28'44"
arc		13.22
tan		7.07
chord:		
28-30	NE	75 57'05"
28-30		12.79
radials:		
28-29	SE	39 17'17"
28-29		15.00
29-30	NE	11 11'27"
29-30		15.00

RP

Dlt, Rad, v, Ex■

Input/Result

E

```
Start, Line, Curve, v, Ex
```

Return to the Cogo menu.

L

```
#30 to #
```

Select the Lines routine.

24 **END LINE**

Inverse back to point #24 to establish the starting point for the next example.

```
hrz[;wrt] angl 30#24
```

END LINE

Bypass this entry.

```
hrz[;wrt] dst 30#24
```

END LINE

Bypass this entry.

```

30-24      SE  78 48'33"
30-24                      117.57
#24                      1781.59 N
#24                      8017.95 E
#24                      486.09 H
#24 to #

```

Example 6: Subdivision

Purpose: To subdivide the parcel as shown.

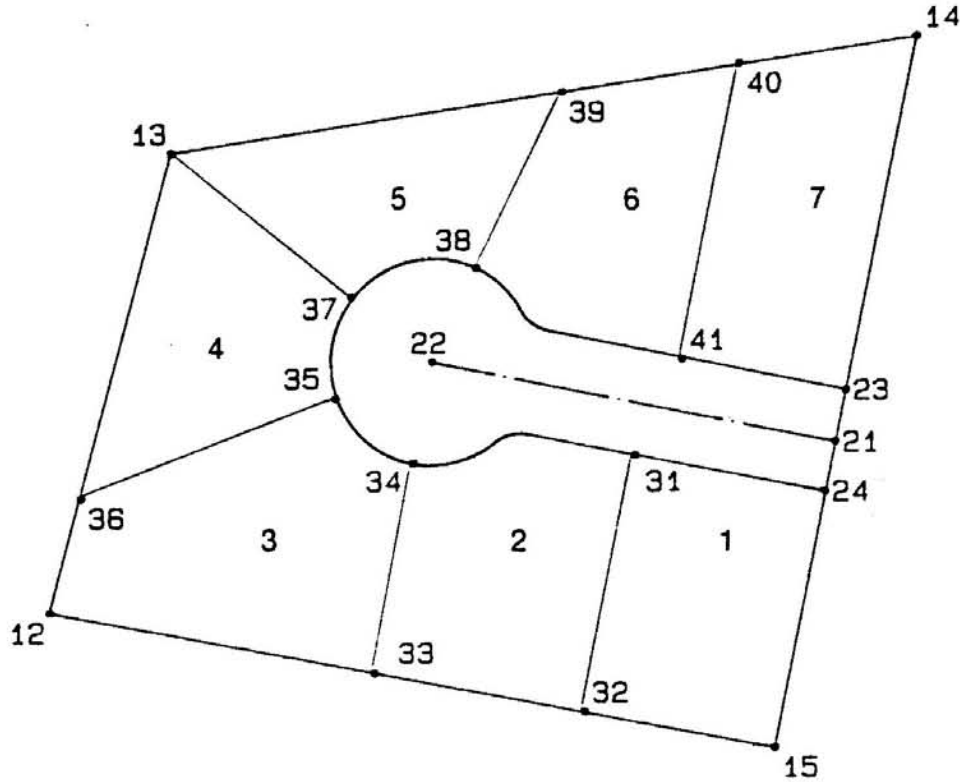

- LOT 1 75 foot frontage; west boundary is perpendicular to the street.
- LOT 2 The west boundary is perpendicular to the south parcel boundary (12-15) and radial to the cul-de-sac.
- LOT 3 The northwest lot boundary is radial to the cul-de-sac, and the lot has a 40 foot frontage as measured on the curve.
- LOT 4 The northeast lot line is radial to the cul-de-sac and extends to the northwest corner of the parcel (pt #13).
- LOT 5 The lot has a 50 foot frontage measured along the chord, and the east boundary is radial to the cul-de-sac.
- LOTS 6 & 7 Point #40 is the midpoint between #39 and #14, and the common lot line is perpendicular to the street.

Lot 1

Input/Result

```
#24 to #■
```

31 **END LINE**

Solve point #31.

```
hrz[;vrt] angl 24*31 ■
```

21*22 **END LINE**

24*30 would also work.

```
hrz[;vrt] dst 24*31 ■
```

75 **END LINE**

Frontage = 75 feet.

24-31	NW	78 48'33"
24-31		75.00
#31		1796.15 N
#31		7944.37 E
#31		486.09 H
#31 to #■		

+ **END LINE**

Increment to #32.

```
hrz[;vrt] angl 31*32 ■
```

+90 **END LINE**

West boundary line is perpendicular to the street.

```
hrz[;vrt] dst 31*32 ■
```

END LINE

Bypass this entry, since the distance is unknown.

```
2nd known #■
```

Input/Result

15

```
#15          1683.49 N
#15          7998.54 E
#15          486.09 H
hrz angl 15#32 ■
```

Use a bearing-bearing intersection with the south parcel boundary.

15#12

```
31-32      SW  11 11'27"
31-32              100.93
15-32      NW  79 31'13"
15-32              75.01
#32          1697.13 N
#32          7924.79 E
```

Defined direction.

Lot 2

Input/Result

```
#32 to #■
```

+

```
hrz[;vrt] angl 32#33 ■
```

Auto-increment to point #33.

15#12

```
hrz[;vrt] dst 32#33 ■
```

```
2nd known #■
```

Unknown, so bypass.

Input/Result

22 **END LINE**

```

#22          1832.26 N
#22          7864.87 E
#22          486.09 H
hrz angl 22*33 ■

```

Cul-de-sac radial point.

15*12-90 **END LINE**

```

32-33      NW  79 31'13"
32-33          83.49
22-33      SW  10 28'47"
22-33          121.98
#33         1712.32 N
#33         7842.69 E
#33 to #■

```

Perpendicular to the boundary.

+ **END LINE**

```

hrz[;vrt] angl 33*34 ■

```

Auto-increment to point #34.

33*22 **END LINE**

```

hrz[;vrt] dst 33*34 ■

```

Radial to cul-de-sac.

33*22-40 **END LINE**

```

33-34      NE  10 28'47"
33-34          81.98
#34         1792.93 N
#34         7857.60 E

```

Computed distance minus 40 foot radius.

Lot 3

Input/Result

#34 to #■

END LINE

Start, Line, Curve, v, Ex■

C

Arc, Chd, Tan, v, Ex■

A

arc length ■

40 END LINE

RP ■

22 END LINE

#34 to #■

Bypass to return to the Cogo menu.

Select the Curve routine.

Traverse on the curve with a known arc distance.

40 foot frontage.

RP of cul-de-sac.

Input/Result

35 **END LINE**

Solve point #35.

```

#35          1817.13 N
#35          7827.84 E
#22          1832.26 N
#22          7864.87 E
#22          486.09 H
delta      AR  57 17'45"
arc                40.00
tan                21.85
chord:
34-35      NW  50 52'20"
34-35                38.35
radials:
34-22      NE  10 28'47"
34-22                40.00
22-35      SW  67 46'32"
22-35                40.00
Arc, Chd, Tan, v, Ex■
    
```

E

Exit the Curve routine.

```
Start, Line, Curve, v, Ex■
```

L

Select the Lines routine.

```
#35 to #■
```

+ **END LINE**

Solve point #36 by a bearing-bearing intersection.

```
hrz[;vrt] angl 35*36 ■
```

22*35 **END LINE**

Radial bearing.

```
hrz[;vrt] dst 35*36 ■
```

Input/Result

END LINE

2nd known #■

Unknown, so bypass.

12 END LINE

```
#12      1735.68 N
#12      7716.40 E
#12      506.80 H
hrz angl 12#36 ■
```

12#13 END LINE

Second known bearing.

```
35-36    SW  67 46'32"
35-36                    109.30
12-36    NE  14 21'17"
12-36                    41.41
#36      1775.79 N
#36      7726.67 E
```

Lot 4

Input/Result

#36 to #■

13 END LINE

Inverse to point #13 to establish the next starting point.

hrz[;vrt] angl 36#13 ■

END LINE

hrz[;vrt] dst 36#13 ■

Input/Result

END LINE

36-13	NE	14 21'17"
36-13		141.87
#13		1913.23 N
#13		7761.84 E
#13		506.11 H
#13 to #		

37 END LINE

Traverse to point #37.

hrz[;vrt] angl 13*37 ■

13*22 END LINE

Radial to the cul-de-sac.

hrz[;vrt] dst 13*37 ■

13*22-40 END LINE

Computed distance minus 40 foot radius.

13-37	SE	51 50'18"
13-37		91.04
#37		1856.98 N
#37		7833.42 E
#37		506.11 H

Lot 5

Input/Result

#37 to #■

END LINE

Bypass to exit the Lines routine.

Start, Line, Curve, v, Ex■

Input/Result

C

Arc, Chd, Tan, v, Ex■

Select the Curve routine.

C

chd length ■

50 foot frontage is measured along the chord.

50 END LINE

rp ■

22 END LINE

37 to #■

38 END LINE

```

#38          1868.36 N
#38          7882.11 E
#22          1832.26 N
#22          7864.87 E
#22          486.09 H
delta      AR  77 21'52"
arc                54.01
tan                32.03
chord:
37-38      NE  76 50'38"
37-38                50.00
radials:
37-22      SE  51 50'18"
37-22                40.00
22-38      NE  25 31'34"
22-38                40.00
Arc, Chd, Tan, v, Ex■

```

Input/Result

E

Start, Line, Curve, v, Ex ■

Exit the Curve routine.

L

#38 to # ■

Select the Lines routine.

+ **END LINE**

Increment to point #39.

hrz[;vrt] angl 38#39 ■

22#38 **END LINE**

Radial.

hrz[;vrt] dst 38#39 ■

END LINE

Unknown.

2nd known # ■

13 **END LINE**

Point on north parcel boundary.

#13	1913.23	N
#13	7761.84	E
#13	506.11	H
hrz angl	13#39	■

13#14 **END LINE**

Intersect with the boundary.

38-39	NE	25 31'34"
38-39		75.28
13-39	NE	81 24'44"
13-39		154.44
#39		1936.29 N
#39		7914.55 E

Lots 6 and 7

Input/Result

```
#39 to #
```

40 **END LINE**

```
hrz[;vrt] angl 39*40
```

39*14 **END LINE**

```
hrz[;vrt] dst 39*40
```

39*14/2 **END LINE**

```
39-40      NE  81 24'44"
39-40              69.85
#40              1946.72 N
#40              7983.61 E
#40 to #
```

41 **END LINE**

```
hrz[;vrt] angl 40*41
```

14*15 **END LINE**

```
hrz[;vrt] dst 40*41
```

END LINE

```
2nd known #
```

Point #40 is located on the north boundary...

and is midway between #39 and #14.

The line between lots 6 and 7 is parallel to the east parcel boundary.

Unknown.

Input/Result

23 END LINE

```
#23          1820.83 N
#23          8025.71 E
#23          486.09 H
hrz angl 23*41 ■
```

21*22 END LINE

```
40-41      SW  11 11'27"
40-41          115.33
23-41      NW  78 48'33"
23-41          65.73
#41          1833.59 N
#41          7961.23 E
```

23*25 is also valid.

Example 7: Lot Summary

Purpose: To compute the areas of lots 1 and 2.

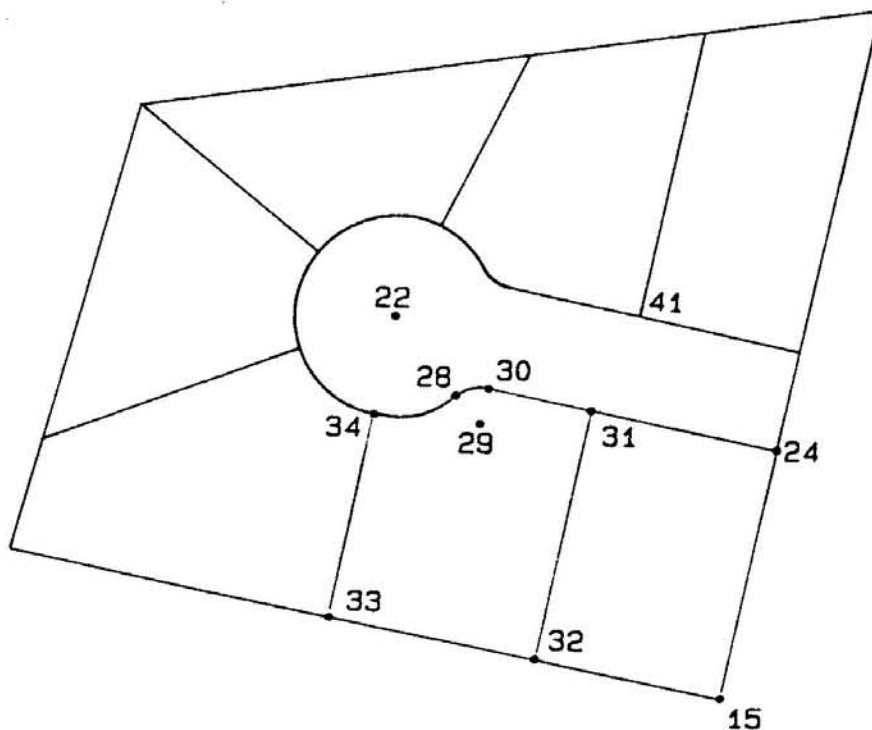

Input/Result

#41 to #■

31 **END LINE**

hrz[;vrt] angl 41#31 ■

END LINE

hrz[;vrt] dst 41#31 ■

END LINE

```

41-31    SW    24 14'28"
41-31                    41.06
#31      1796.15 N
#31      7944.37 E
#31      486.09 H
#31 to #■

```

END LINE

Start,Line,Curve,v,Ex■

▼

Radial,Area,v,Ex■

Inverse back to #31 to establish the next starting point.

Exit the Lines routine.

Skip to the next menu.

Input/Result

A

Select the Area/Traverse function.

#31 to # [;thru] ■

32 **END LINE**

Traverse around Lot 1.

```

31-32    SW   11 11'27"
31-32                100.93
#32      1697.13 N
#32      7924.79 E
#32 to # [;thru] ■

```

31-32-15-24-31.

15 **END LINE**

```

32-15    SE   79 31'13"
32-15                75.01
#15      1683.49 N
#15      7998.54 E
#15      486.09 H
#15 to # [;thru] ■

```

24 **END LINE**

```

15-24    NE   11 11'27"
15-24                100.00
#24      1781.59 N
#24      8017.95 E
#24      486.09 H
#24 to # [;thru] ■

```

Input/Result

31 **END LINE**

```

24-31    NW   78 48'33"
24-31                75.00
#31      1796.15 N
#31      7944.37 E
#31      486.09 H
#31 to # [;thru] ■
    
```

You must return to the starting point.

END LINE

```

sq ft          7534.90
acres          0.17
Radial,Area,v,Ex■
    
```

Make no entry to close.

A

```

#31 to # [;thru] ■
    
```

Begin Lot 2.

32;34 **END LINE**

```

31-32    SW   11 11'27"
31-32                100.93
#32      1697.13 N
#32      7924.79 E
32-33    NW   79 31'13"
32-33                83.49
#33      1712.32 N
#33      7842.69 E
33-34    NE   10 28'47"
33-34                81.98
#34      1792.93 N
#34      7857.60 E
#34 to # [;thru] ■
    
```

Automatically inverses between 31-32-33-34.

Input/Result

-22 END LINE

point #■

Use a negative radial point to flag the curve.

28 END LINE

```

#28          1801.30 N
#28          7890.20 E
#22          1832.26 N
#22          7864.87 E
#22          486.09 H
delta      RL  49 46'04"
arc                34.74
tan                18.55
chord:
34-28      NE  75 35'45"
34-28                33.66
radials:
34-22      NE  10 28'47"
34-22                40.00
22-28      SE  39 17'17"
22-28                40.00
#28 to # [;thru] ■
    
```

Point of tangency.

-29 END LINE

point #■

Radial point of curb return.

Input/Result30 **END LINE**

```

#30          1804.41 N
#30          7902.61 E
#29          1789.69 N
#29          7899.70 E
delta      AR  50 28'44"
arc                13.22
tan                7.07
chord:
28-30      NE  75 57'05"
28-30                12.79
radials:
28-29      SE  39 17'17"
28-29                15.00
29-30      NE  11 11'27"
29-30                15.00
#30 to # [;thru] ■

```

Point of tangency.

31 **END LINE**

```

30-31      SE  78 48'33"
30-31                42.57
#31          1796.15 N
#31          7944.37 E
#31          486.09 H
#31 to # [;thru] ■

```

Return to the starting point.

END LINE

```

sq ft          8041.92
acres           0.18
Radial,Area,v,Ex■

```

Close the figure to display the area.

Example 8: Radial Stakeout

Purpose: From point #22 (center of the cul-de-sac), to compute and display the staking data for all solved points.

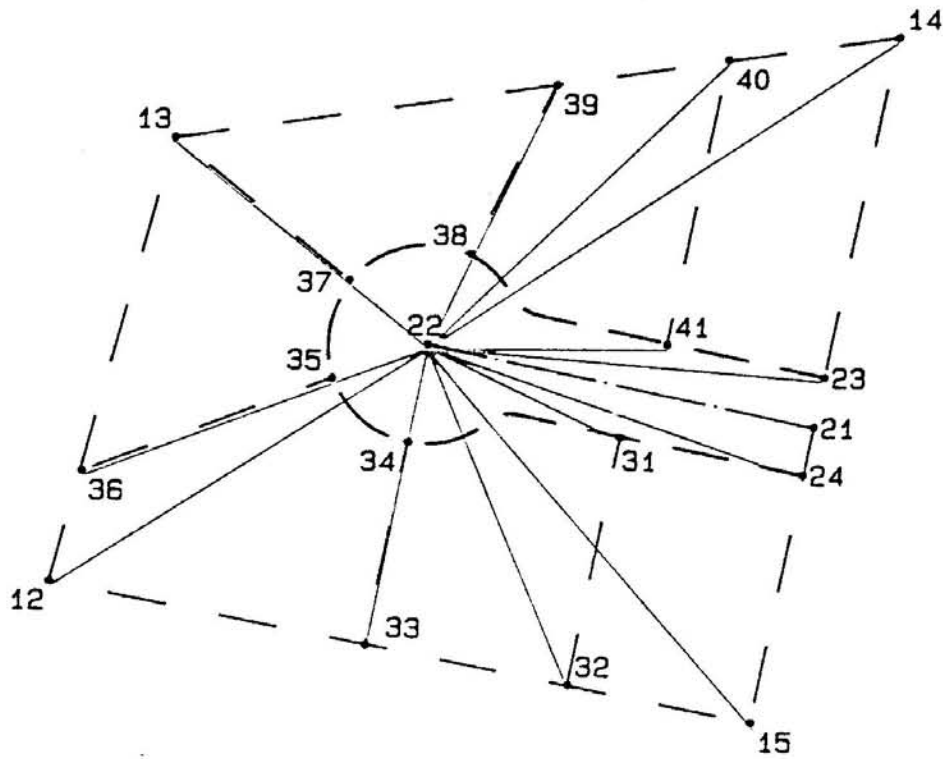

Input/Result

Radial, Area, v, Ex ■



Skip to the next menu.

Start, Line, Curve, v, Ex ■



Select the Start function to establish the instrument point and backsight.

from # ■

Input/Result22 **END LINE**

```
#22      1832.26 N
#22      7864.87 E
#22      486.09 H
backsight ■
```

Set up on point #22 (center of the cul-de-sac).

22*21 **END LINE**

```
b.s.      SE 78 48'33"
angls Abs,Field ■
```

Backsight down the roadway center line.

F

Start,Line,Curve,v,Ex ■

Select field angles (deflections) for output.

▼

Radial,Area,v,Ex ■

Next menu.

R

#22 to # [; thru] ■

Select the Radial Stakeout routine.

31;41 **END LINE**

```
22-31    DL 166 45'34"
22-31           87.32
#31      1796.15 N
#31      7944.37 E
#31      486.09 H
22-32    DL 125 06'10"
22-32           147.81
#32      1697.13 N
#32      7924.79 E
```

Staking data for points #31 thru #41, inclusive, will be displayed.

All distances are from point #22 and deflection angles are turned from the street center line.

Input/Result

22-33	DL	90 42'39"
22-33		121.98
#33		1712.32 N
#33		7842.69 E
22-34	DL	90 42'39"
22-34		40.00
#34		1792.93 N
#34		7857.60 E
22-35	DL	33 24'55"
22-35		40.00
#35		1817.13 N
#35		7827.84 E
22-36	DL	33 24'55"
22-36		149.30
#36		1775.79 N
#36		7726.67 E
22-37	DR	26 58'15"
22-37		40.00
#37		1856.98 N
#37		7833.42 E
#37		506.11 H
22-38	DR	104 20'07"
22-38		40.00
#38		1868.36 N
#38		7882.11 E
22-39	DR	104 20'07"
22-39		115.28
#39		1936.29 N
#39		7914.55 E
22-40	DR	124 51'41"
22-40		164.93
#40		1946.72 N
#40		7983.61 E
22-41	DR	168 01'20"
22-41		96.37
#41		1833.59 N
#41		7961.23 E
#22 to #E; thru] ■		

Input/Result

END LINE

Radial, Area, v, Ex■

E

File, Cogo, User, Ex■

E

Exited Survey

Bypass to Radial menu.

Exit to main surveying menu.

End of examples; exit the Surveying Pac.

Appendix A

Owner's Information

Maintenance	104
Limited One-Year Warranty	104
What We Will Do	104
What Is Not Covered	104
Warranty for Consumer Transactions in the United Kingdom	105
Obligation to Make Changes	105
Warranty Information	105
Service	106
Service Centers	106
Obtaining Repair Service in the United States	106
Obtaining Repair Service in Europe	107
International Service Information	108
Service Repair Charge	108
Service Warranty	108
Shipping Instructions	108
Further Information	109
When You Need Help	109

Maintenance

The surveying module does not require maintenance. However, there are several precautions, listed below, that you should observe.

CAUTIONS

- Do not place fingers, tools, or other objects into the plug-in ports. Damage to plug-in module contacts and the computer internal circuitry may result.
- Turn off the computer (press OFF) before installing or removing a plug-in module.
- If a module jams when inserted into a port, it may be upside down. Attempting to force it further may result in damage to the computer or the module.
- Handle the plug-in modules very carefully while they are out of the computer. Do not insert any objects in the module connector socket. Always keep a blank module in the computer port when a module is not installed. Failure to observe these cautions may result in damage to the module or the computer.

Limited One-Year Warranty

What We Will Do

The Surveying Pac is warranted by Hewlett-Packard against defects in materials and workmanship affecting electronic and mechanical performance, but not software content, for one year from the date of original purchase. If you sell your unit or give it as a gift, the warranty is transferred to the new owner and remains in effect for the original one-year period. During the warranty period, we will repair or, at our option, replace at no charge a product that proves to be defective, provided you return the product, shipping prepaid, to a Hewlett-Packard service center.

What Is Not Covered

This warranty does not apply if the product has been damaged by accident or misuse or as the result of service or modification by other than an authorized Hewlett-Packard service center.

No other express warranty is given. The repair or replacement of a product is your exclusive remedy. **ANY OTHER IMPLIED WARRANTY OF MERCHANTABILITY OR FITNESS IS LIMITED TO THE ONE-YEAR DURATION OF THIS WRITTEN WARRANTY.** Some states, provinces, or countries do not allow limitations on how long an implied warranty lasts, so the above limitation may not apply to you. **IN NO EVENT SHALL HEWLETT-PACKARD COMPANY BE LIABLE FOR CONSEQUENTIAL DAMAGES.** Some states, provinces, or countries do not allow the exclusion or limitation of incidental or consequential damages, so the above limitation or exclusion may not apply to you.

This warranty gives you specific legal rights, and you may also have other rights that vary from state to state, province to province, or country to country.

Warranty for Consumer Transactions in the United Kingdom

This warranty shall not apply to consumer transactions and shall not affect the statutory rights of a consumer. In relation to such transactions, the rights and obligations of Seller and Buyer shall be determined by statute.

Obligation to Make Changes

Products are sold on the basis of specifications applicable at the time of manufacture. Hewlett-Packard shall have no obligation to modify or update products once sold.

Warranty Information

If you have any questions concerning this warranty, please contact an authorized Hewlett-Packard dealer or a Hewlett-Packard sales and service office. Should you be unable to contact them, please contact:

- In the United States:

Hewlett-Packard Company
 Personal Computer Group
 Customer Support
 11000 Wolfe Road
 Cupertino, CA 95014
 Toll-Free Number: (800) FOR-HPCC (800 367-4772)

- In Europe:

Hewlett-Packard S.A.
 150, route du Nant-d'Avril
 P.O. Box CH-1217 Meyrin 2
 Geneva
 Switzerland
 Telephone: (022) 83 81 11

Note: Do not send units to this address for repair.

• In other countries:

Hewlett-Packard Intercontinental
3495 Deer Creek Rd.
Palo Alto, California 94304
U.S.A.
Telephone: (415) 857-1501

Note: Do *not* send units to this address for repair.

Service

Service Centers

Hewlett-Packard maintains service centers in most major countries throughout the world. You may have your unit repaired at a Hewlett-Packard service center any time it needs service, whether the unit is under warranty or not. There is a charge for repairs after the one-year warranty period.

Hewlett-Packard products are normally repaired and reshipped within five (5) working days of receipt at any service center. This is an average time and could vary depending upon the time of year and the work load at the service center. The total time you are without your unit will depend largely on the shipping time.

Obtaining Repair Service in the United States

The Hewlett-Packard United States Service Center for battery-powered computational products is located in Corvallis, Oregon:

Hewlett-Packard Company
Service Department
P.O. Box 999
Corvallis, Oregon 97339, U.S.A.
or
1030 N.E. Circle Blvd.
Corvallis, Oregon 97330, U.S.A.
Telephone: (503) 757-2000

Obtaining Repair Service in Europe

Service centers are maintained at the following locations. For countries not listed, contact the dealer where you purchased your unit.

AUSTRIA

HEWLETT-PACKARD Ges.m.b.H.
Kleinrechner-Service
Wagramerstrasse-Lieblgasse 1
A-1220 Wien (Vienna)
Telephone: (0222) 23 65 11

BELGIUM

HEWLETT-PACKARD BELGIUM SA/NV
Woluwedal 100
B-1200 Brussels
Telephone: (02) 762 32 00

DENMARK

HEWLETT-PACKARD A/S
Datavej 52
DK-3460 Birkerod (Copenhagen)
Telephone: (02) 81 66 40

EASTERN EUROPE

Refer to the address listed under Austria.

FINLAND

HEWLETT-PACKARD OY
Revontulentie 7
SF-02100 Espoo 10 (Helsinki)
Telephone: (90) 455 02 11

FRANCE

HEWLETT-PACKARD FRANCE
Division Informatique Personnelle
S.A.V. Calculateurs de Poche
F-91947 Les Ulis Cedex
Telephone: (6) 907 78 25

GERMANY

HEWLETT-PACKARD GmbH
Kleinrechner-Service
Vertriebszentrale
Berner Strasse 117
Postfach 560 140
D-6000 Frankfurt 56
Telephone: (611) 50041

ITALY

HEWLETT-PACKARD ITALIANA S.P.A.
Casella postale 3645 (Milano)
Via G. Di Vittorio, 9
I-20063 Cernusco Sul Naviglio (Milan)
Telephone: (2) 90 36 91

NETHERLANDS

HEWLETT-PACKARD NEDERLAND B.V.
Van Heuven Goedhartlaan 121
NL-1181 KK Amstelveen (Amsterdam)
P.O. Box 667
Telephone: (020) 472021

NORWAY

HEWLETT-PACKARD NORGE A/S
P.O. Box 34
Oesterndalen 18
N-1345 Oesteraas (Oslo)
Telephone: (2) 17 11 80

SPAIN

HEWLETT-PACKARD ESPANOLA S.A.
Calle Jerez 3
E-Madrid 16
Telephone: (1) 458 2600

SWEDEN

HEWLETT-PACKARD SVERIGE AB
Skalholtsgatan 9, Kista
Box 19
S-163 93 Spanga (Stockholm)
Telephone: (08) 750 20 00

SWITZERLAND

HEWLETT-PACKARD (SCHWEIZ) AG
Kleinrechner-Service
Allmend 2
CH-8967 Widn
Telephone: (057) 31 21 11

UNITED KINGDOM

HEWLETT-PACKARD Ltd
King Street Lane
GB-Winnersh, Wokingham
Berkshire RG11 5AR
Telephone: (0734) 784 774

International Service Information

Not all Hewlett-Packard service centers offer service for all models of HP products. However, if you bought your product from an authorized Hewlett-Packard dealer, you can be sure that service is available in the country where you bought it.

If you happen to be outside of the country where you bought your unit, you can contact the local Hewlett-Packard service center to see if service is available for it. If service is unavailable, please ship the unit to the address listed above under "Obtaining Repair Service in the United States." A list of service centers for other countries can be obtained by writing to that address.

All shipping, reimportation arrangements, and customs costs are your responsibility.

Service Repair Charge

There is a standard repair charge for out-of-warranty repairs. The repair charges include all labor and materials. In the United States, the full charge is subject to the customer's local sales tax.

Computer products damaged by accident or misuse are not covered by the fixed repair charge. In these situations, repair charges will be individually determined based on time and materials.

Service Warranty

Any out-of-warranty repairs are warranted against defects in materials and workmanship for a period of 90 days from date of service.

Shipping Instructions

Should your unit require service, return it with the following items:

- A completed Service Card, including a description of the problem.
- A sales receipt or other proof of purchase date if the one-year warranty has not expired.

The product, the Service Card, a brief description of the problem, and (if required) the proof of purchase date should be packaged in adequate protective packaging to prevent in-transit damage. Such damage is not covered by the one-year limited warranty; Hewlett-Packard suggests that you insure the shipment to the service center. The packaged unit should be shipped to the nearest Hewlett-Packard designated collection point or service center. Contact your dealer for assistance.

Whether the unit is under warranty or not, it is your responsibility to pay shipping charges for delivery to the Hewlett-Packard service center.

After warranty repairs are completed, the service center returns the unit with postage prepaid. On out-of-warranty repairs in the United States and some other countries, the unit is returned C.O.D. (covering shipping costs and the service charge).

Further Information

Computer products circuitry and design are proprietary to Hewlett-Packard, and service manuals are not available to customers. Should other problems or questions arise regarding repairs, please call your nearest Hewlett-Packard service center.

When You Need Help

Hewlett-Packard is committed to providing after-sale support of its customers. To this end, our customer support department has established phone numbers that you can call if you have questions about this product.

Product Information. For information about Hewlett-Packard dealers, products, and prices, call the toll-free number below:

(800) FOR-HPPC
(800 367-4772)

Technical Assistance. For technical assistance with your product, call the number below:

(503) 754-6666

For either product information or technical assistance, you can also write to:

Hewlett-Packard
Personal Computer Group
Customer Support
11000 Wolfe Road
Cupertino, CA 95014

Error Conditions and Recovery

The Surveying Pac programs have been designed to trap errors without aborting program execution. All input values are checked for valid syntax and, if an error is found, the computer will display a warning message and return to the previous prompt. You can then enter the correct value.

Syntax errors commonly occur when a letter or symbol is entered when a number is expected. You can also get an error message when using unassigned point numbers to define a direction or distance, or entering a point number larger than the file size.

Incorrect use of commas is another common cause of problems. Commas are used to separate two or more input values. They should not be used as digit separators or radix symbols. For example, the number ten thousand should be entered as 10000, and not 10,000.

The Coordinate file is continually and immediately updated as you work. If an error does occur that causes program execution to stop, you generally will have lost no more than a single point. The program can easily be restarted, and work continued at the point where the error occurred.

The following error messages are generated by the Surveying Pac programs. Other error messages are "system" messages and are explained in "Errors, Warnings, and System Messages" in the *HP-71 Reference Manual*.

Invalid Angle

- The angle entered cannot be interpreted. Refer to page 15 for accepted angle entries.

Invalid Direction

- The direction entered cannot be interpreted. Refer to page 16 for accepted direction entries.

Invalid Distance

- The distance entered cannot be interpreted. Refer to page 21 for accepted distance entries.

Invalid Point

- The point entered cannot be interpreted. Refer to page 21 for accepted point entries.

Invalid Size

- Reenter a file size within the displayed range; the size entered is outside that range.

Point Not Stored

- A point referenced in the calculation was not stored. Enter the point and rerun the calculation.

No User Pgm Present

- A user program does not exist in RAM. Refer to appendix C.

Programs and Subprograms

The surveying module contains five named files: SURVEY, SURVEY71, SURV3, SurveyW, and KEYWAIT. With the exception of SURV3, these names must not be used as the names of files in user memory, as the HP-71 first searches its own memory before searching the plug-in modules. This appendix describes each file and tells how to call the subprograms.

Main Program SURVEY

The code contained in SURVEY is merely a call to the real main program contained in SURVEY71. This allows us to completely preserve your global environment by localizing the SURVEY environment.

SURVEY can be run without a file name conflict by entering `RUN SURVEY:PORT(x)`, where *x* is the number of the port that the surveying module is plugged into.

Subprogram SURVEY71

SURVEY71 is the main program in the Surveying Pac, although it exists as a subprogram. SURVEY71 contains most of the other subprograms. The data file is created and initialized in this code, and data output specifications are entered. There are no parameters for this subprogram.

Subprogram SURV1

SURV1 contains the File Management routines: assign data to coordinates, list, clear, duplicate, balance, rotate, translate, and scale coordinates.

Sample call: `CALL SURV1(#1,M1,U,I2#,I3#)`

Parameters:

#1 is the channel number for the open data file.

M1 indicates the direction (absolute angles) output mode:

- 1 = bearings
- 2 = north azimuths
- 3 = south azimuths

U indicates the angular units:

- 1 = degrees
- 2 = grads

I2# is the output format string for coordinates.

I3# is the output format string for distances.

Subprogram SURV2

SURV2 contains the Coordinate Geometry routines: start, line, curve, radial, and area.

Sample call: CALL SURV2(#1, M1, M2, U, L5, I1#, I2#, I3#)

Parameters:

#1 is the channel number for the open data file.

M1 indicates the direction (absolute angles) output mode:

- 1 = bearings
- 2 = north azimuths
- 3 = south azimuths

M2 indicates the relative angle output mode:

- 4 = deflections
- 5 = angles right/left

U indicates angular units:

- 1 = degrees
- 2 = grads

L5 is the value 10^P , where P is the number of decimals of seconds or angles to be displayed. L5 is used to calculate the answer to the specified number of decimal places.

I1# is the output format string for angles.

I2# is the output format string for coordinates.

I3# is the output format string for distances.

Subprogram IA (Input Angle)

This subprogram accepts an input string and returns a numeric angle in decimal degrees.

Sample call: CALL IA((A1\$),F,A,U)

Parameters:

A1\$ is the input string and is modified by IA. Enclosing it in parentheses indicates to pass A1\$ by value.

F is the returned success flag:

- 0 = the input is invalid.
- 1 = the input is valid.
- 1 = a null string is entered.

A is the returned angle in decimal degrees.

U indicates degrees or grads mode:

- 1 = degrees mode
- 2 = grads mode

Subprogram IB (Input Bearings)

This subprogram accepts an input string and converts it to a numeric azimuth in decimal degrees. It will also reduce a vertical or zenith angle input and normalize the result.

Sample call: CALL IB(#1,B\$,Z\$,A0,U,F,G2)

Parameters:

#1 is the coordinate file channel number.

B\$ is the string for the horizontal direction.

Z\$ is the string for the vertical or zenith angle. If not used, enter a null string.

A0 is the backsight azimuth on entry; A0 is the returned numeric azimuth in decimal degrees.

U indicates degrees or grads mode:

- 1 = degrees mode
- 2 = grads mode

F is the returned success flag:

- 1 = a null string was entered
- 0 = invalid entry
- 1 = valid input

G2 is the returned zenith angle.

Subprogram ID (Input Distance)

This subprogram accepts an input string and returns a numeric distance.

Sample call: CALL ID(#1, D\$, D1\$, F, D, V)

Parameters:

#1 is the coordinate file channel number.

D\$ is the horizontal or slope distance.

D1\$ is the vertical distance (null string if not used).

F is the returned success flag:

-1 = a null string was entered

0 = invalid entry

1 = valid entry

D is the returned horizontal distance.

V is the returned vertical distance.

Subprogram IP (Input Points)

This subprogram accepts input strings for point numbers and returns numeric values for the point numbers and signs.

Sample call: CALL IP(#1, A1\$, A2\$, P, T6(), T7(), F)

Parameters:

#1 is the coordinate file channel number.

A1\$ is the input string for the first point number.

A2\$ is the optional input string for the second point number.

P is the point number of the last point entered.

T6() is a four-element array. The first element contains the first point number; the second element contains the second point number if it exists.

T7() is a four-element array. The first element contains the sign of the first point number (1 = a positive number, -1 = a negative number); the second element contains the sign of the second point number if it exists.

F is the returned success flag:

0 = invalid point number

1 = the point number was accepted

Subprogram BB (Bearing—Bearing Intersection)

This subprogram solves the intersection of two lines.

Sample call: CALL BB(T6(), T7(), S1, S2, F, N2, E2)

Parameters:

T6() is a four-element array. The first array element is the northing of the first point; the second array element contains the northing of the second point.

T7() is a four-element array. The first array element contains the easting of the first point; the second array element contains the easting of the second point.

S1 is the azimuth from the first point.

S2 is the azimuth from the second point.

F is the success flag:

1 = impossible solution

0 = valid solution

N2 is the returned northing of the point of intersection.

E2 is the returned easting of the point of intersection.

Subprogram DD (Distance—Distance Intersection)

This subprogram solves the intersections of two circles.

Sample call: CALL DD(T6(), T7(), D1, D2, F)

Parameters:

T6() is a four-element array. On entry, the northings of the first two points are contained in the first two elements respectively. The northings for the near and far solution points are returned in the first two elements.

T7() is a four-element array. On entry, the eastings of the first two points are contained in the first two elements respectively. The eastings for the near and far solution points are returned in the first two elements.

D1 is the azimuth from the first point.

D2 is the distance from the second point.

F is the success flag:

1 = the solution is impossible

0 = a solution was found

Subprogram `BD` (Bearing-Distance Intersection)

This subprogram solves the intersections between a line and a circle.

Sample call: `CALL BD(T6(),T7(),A1,D2,F)`

Parameters:

`T6()` is a four-element array. The northings of the first two points are contained in the first two elements respectively. The northings for the near and far solution points are returned in the first two elements, respectively.

`T7()` is a four-element array. The eastings of the first two points are contained in the first two elements respectively. The eastings for the near and far solution points are returned in the first two elements, respectively.

`A1` is the azimuth from the first point.

`D2` is the distance from the second point.

`F` is the success flag:

- 1 = the solution is impossible
- 0 = a solution was found

Subprogram `DA` (Output Angles)

This subprogram outputs (prints or displays) angles using selected units and formats. No values are returned to the calling program.

Sample call: `CALL DA(A,A0,M,S#,I1#,U,L5)`

Parameters:

`A` is the azimuth to be output in degrees.

`A0` is the backsight angle to be output in degrees.

`M` is the output mode:

- 1 = bearing
- 2 = north azimuth
- 3 = south azimuth
- 4 = deflection
- 5 = angles right or left

`S#` is the string to be output with the angle, i.e. `backsight`.

`I1#` is the output format string.

U indicates degrees or grads mode:

1 = degrees mode

2 = grads mode

L5 indicates the number of fractional digits on angles.

Subprogram SURV3

SURV3 is the hook into the surveying module to add a routine of your choice. The SURV3 routine is a 'dummy' routine that displays the error message No User Pgm Present. This routine is overridden by a routine named SURV3 in user memory.

Sample subprogram: SUB SURV3(#1,U)

Parameters:

#1 is the coordinate data file channel number.

U indicates angular units:

1 = degrees

2 = grads

Example: Key in the following subprogram. This routine will list all of the unassigned point numbers in the current coordinate file. Before keying in this subprogram, type EDIT SURV3:MAIN and press **END LINE** to position the file pointer to user memory rather than the module subprogram.

```

10 SUB SURV3(#1,G)
20 ! LIST UNASSIGNED POINT NUMBERS FROM COORD FILES
30 READ #1,1;P0
40 F=0 @ F2=1
50 PRINT 'UNASSIGNED POINTS'
60 FOR I=5 TO P0+4
70 READ #1,I;J
80 IF J<-999998 AND F=0 OR J>-999998 AND F=1 THEN 100
90 GOTO 130
100 IF F=0 THEN K=I-4 @ F=1 @ F2=0 @ GOTO 130
110 IF K=I-5 THEN PRINT I-5 @ F=0 @ F2=0 @ GOTO 130
120 PRINT K;'-';I-5 @ F=0 @ F2=0
130 NEXT I
140 IF F2 THEN PRINT ' None' @ END
150 IF F=0 THEN END
160 IF K=I-5 THEN PRINT I-5 ELSE PRINT K;'-';I-5 @ F2=0
170 END SUB

```

To execute SURV3, press **U** when the File,Cogo,User,Ex menu is displayed. After the unassigned point numbers are printed, the program continues with the File,Cogo,User,Ex menu.

SurveyW

SurveyW is a LEX file that responds to VER#, indicating the current software version of the surveying module.

KEYWAIT

KEYWAIT is a LEX file containing KEYWAIT#. KEYWAIT# waits in a low power state until a key is pressed and then returns the key name. This is similar to KEY#.

Appendix D

The Coordinate File

The coordinate file is created in the SURVEY program and is assigned to file #1. In addition to the coordinates, lines 0-4 contain the following variables for units and output modes:

Line 0:

The string "HPRFNNN" indicating HP Applications Format consisting of records containing three numbers each.

Line 1:

The maximum number of points in the file.

Line 2:

The record number of the column names, after the data. ($n+5$ where n is the maximum number of points.)

Line 3:

Angular units (where 1 refers to degrees and 2 to grads).

The direction mode in absolute angles (where 1 refers to bearings, 2 to north azimuths, and 3 to south azimuths).

The field angle mode (where 4 refers to deflections and 5 to angles right/left).

Line 4:

The number of fractional digits on angles.

The number of fractional digits on coordinates.

The number of fractional digits on distances.

Lines 5 to $n+4$:

The N, E, and H coordinates. (N, E, or H = -999999 when initialized or unassigned.)

Line $n+5$:

COLNAMS, 3, Northing, Easting, Height

This data may be accessed by RESTORing the data file to record $n+5$, then serially reading the COLNAMS header string, the number of headers, then the three headers.

Appendix E

Glossary

A

angle balance: The process of distributing the angular error in a traverse by applying a correction to the direction of each leg.

arc: The curved portion of a circular segment.

azimuth: The direction of a line defined by the clockwise angle between a meridian and the line.

B

backsight: A sight or observation taken to a point, usually in the rear, to establish a reference direction from which to measure horizontal angles.

bearing: The direction of a line defined by the quadrant and acute angle (clockwise or counterclockwise) between a meridian and the line.

C

central angle: See delta.

chord: The straight line from the point of curvature to the point of tangency of a curve.

D

degree: A unit of angular measure equal to one 360th of a circle.

delta: The central angle of a curve; the angle between radials to the point of curvature and the point of tangency of a curve, or between the tangents.

E

easting: The distance of a point from the origin as measured parallel to the X-axis.

elevation: The vertical distance of a point above or below an arbitrarily assumed level surface or datum.

F

foresight: A sight taken to a point along a line whose direction is to be determined or established.

G

grad: A unit of angular measurement equal to one 400th of a circle.

H

horizontal angle: An angle formed by the intersection of two lines in a horizontal plane.

horizontal distance: The distance between two points as measured along the projection onto a horizontal plane.

I

inverse: An operation to determine the direction and length of a line between two points.

L

linear balance: A method for distributing the linear error of closure in a traverse by applying a correction to the length of each leg.

M

meridian: A fixed line of reference for measuring horizontal angles.

N

northing: The distance of a point from the origin as measured parallel to the Y-axis.

O

origin: An arbitrary point with assigned coordinate values 0,0 that will serve as a reference for other points in the coordinate system.

P

point of curvature (PC): The point where a circular curve begins. It also refers to "beginning of curve" and "tangent to curve."

point of tangency (PT): The point where a circular curve ends. It also refers to "end of curve" and "curve to tangent."

R

radial point (RP): The center point of a circular curve.

radius: The line extending from the center of a circle to the curve.

S

slope distance: The distance between two points as measured on a slope or grade.

T

tangent: A line that intersects a circular curve at a single point and is perpendicular to the radial at that point.

traverse: The operation to establish the location of a new point at a given distance and direction from another point. Also, a series of straight lines connecting a succession of points along the route of a survey.

vertical angle: An angle between two intersecting lines in a vertical plane. In surveying, a vertical angle is usually measured from a line on the horizontal plane.

vertical distance: The difference in elevation between two points.

zenith angle: A vertical angle measured from a line perpendicular to the horizontal plane (as a plumb line).

Subject Index

Page numbers in **bold type** indicate primary references; page numbers in standard type indicate secondary references. Index references to routines are followed by *routine*.

A

- Angle balance, **27**
- Angles, **15**
 - deflection, **19**
 - entering, **15-16**
 - field, **15, 16, 35-36**
 - in degrees, **15**
 - in grads, **15**
- Angles left, right **15, 16, 19**
 - entering, **15, 19**
 - measuring, **19**
- Arc length, **35, 47, 48**
- Area/Traverse (*routine*) **54-55**
- Assigning coordinates, **22, 60-61**
- Assign (*routine*), **24, 26**
- Auto-increment, **21, 60**, See also Point numbers
- Azimuths, **18**
 - entering, **18**
 - measuring, **18**

B

- BB, **116**, See also Bearing-Bearing intersection
- BD, **117**, See also Bearing-Distance intersection
- Backsight, **35, 36**
 - establishing, **62**
- Balance Traverse (*routine*), **24, 27-30, 68-69**
- Bearing-Bearing intersection, **36, 42, 86**
- Bearing-Distance intersection, **36, 43-44**
- Bearings, **17**
 - entering, **17**
 - measuring, **17**
- Bowditch rule, **28, 30, 66, 69**

C

- Cautions, **9-10, 103**
- Central angle, **35, 47, 48, 49**
- Chord length, **35, 47, 48**
- Clear Coordinates (*routine*), **24, 27**
- COGO, **12, 33-55**
 - selecting, **13**
 - menu, **34**
 - multiple solutions, **37, 43, 45**
- Compass rule. See Bowditch rule
- Conventions used, **12-22**
- Coordinate files, **10, 12, 14**
 - creating, **10-11, 14, 58-59**
 - copying, **14**
 - format of, **120**
 - making room for, **14**
- Coordinate Geometry, **12, 33-55**, See also COGO
- Coordinates,
 - assigning, to a point, **22, 60-61**
 - Assign (*routine*), **26**
 - Clear (*routine*), **24, 27**
 - List (*routine*), **24, 26**
 - Scale (*routine*), **31**
- COPY, **14**
- Crandall's rule, **28, 30**
- Curve Traverse (*routine*), **47, 48-49**
- Curves (*routine*), **35, 47-48, 76-80**

D

- DD, **116**, See also Distance-Distance intersection
- Data entry, **15, 16-22, 36-37**
 - by mathematical expressions for angles, **15**
 - by mathematical expressions for distances, **21**
 - for a traverse, **63-65**
- Dealer information, **109**
- Deflection angles, **20**
- DELAY, **22**
- Delta. See Central angle

Directions, 16
 defining, for entry, 20
 entering, 16-20
 Distance-Bearing intersection, 44-45
 Distance-Distance intersection, 36, 46-47
 Distances, entering, 21
 Duplicate Points (*routine*), 24, 27, 66

E

Elevation
 adjustment, 28
 input, 22, 40, 68
 Error conditions, 110
 Exiting the Surveying Pac, 12

F

Field angles, 15, 16, 35-36
 File, 12
 selecting, 12
 See also File Management program
 File Management program, 12, 23
 routines, 24-31

I

IA (*Input Angle*), 114
 IB (*Input Bearing*), 114
 ID (*Input Distance*), 115
 IP (*Input Points*), 115
 Input data. See Data entry
 Input and output options, 15
 angular units, 15-16
 directions, 16-20
 Inscribe Curve (*routine*), 49-52
 Intersection
 of two lines, 36, 42
 of a line and a circle, 36, 43-45
 of two circles, 36, 46-47
 Inverse, 36, 41

K-L-M

KEYWAIT, 119
 Lines (*routine*), 35, 36-37, 38, 73-76
 List Coordinates (*routine*), 24, 26
 Maintenance, 104
 Menus, 12-13
 accessing, 13, 24-25
 Module,
 installing, 9
 removing, 9
 Multiple solutions, 37

O

OA (*Output Angles*), 117
 Occupied point (*p1*), 35, 38, 40, 41, 42, 43, 44, 45,
 46, 48, 49, 55
 establishing, 62
 Output, 22

P

p1 See Occupied point
 PC (*point of curvature*), 35, 47, 48, 49, 51, 52, 55
 PT (*point of tangency*), 35, 47, 48, 49, 51, 52
 Pointers, reset internal, 10
 Point numbers, 14, 21
 Product information, 109
 Program conventions, 12-22
 Program files, 14
 Programs, 112

R

RP (*radial point*), 35, 47, 48, 49, 51, 52
 Radial Stakeout (*routine*), 53, 99
 radii unequal, 55
 Repair service, 106-108
 Reset internal pointers, 10
 Rotate Points (*routine*), 24, 30
 Running SURVEY, 10-12

S

Scale Coordinates (*routine*), 24, 31
 Service, 106-109
 Start (*routine*), 35, 73
 Sideshot, 36, 41
 Slope distances, 39
 Stakeout. See Radial Stakeout
 Subprograms, 112
 Suspend operation, 12
 SURVEY, 10, 11, 12, 14, 112
 running, 10
 SURVEYW, 119
 SURVEY71, 112
 SURV1, 112
 SURV2, 112
 SURV3, 12, 13, 118
 selecting, 13

T-U

Tangent length, 35, 47, 49
Technical assistance, 109
Translate Points (*routine*), 24, 31
Traverse, 27, 28, 29, 35, 39-40, 61-66
 Adjustment (*routine*), 27-30
 Balance (*routine*), 27-30, 66-69
 Curves (*routine*), 47-52
Traverse Input (*routine*), 27-30
Traversing lines, 39-40
User, 12

V-W

Vertical distances, 40
Warranty information, 104-106

- How To Use This Manual (page 7)**
- 1: Getting Started (page 9)**
 - 2: File Management (page 23)**
 - 3: Coordinate Geometry (page 33)**
 - 4: Examples (page 57)**
-
- A: Owner's Information (page 103)**
 - B: Error Conditions and Recovery (page 110)**
 - C: Programs and Subprograms (page 112)**
 - D: The Coordinate File (page 120)**
 - E: Glossary (page 121)**



Portable Computer Division
1000 N.E. Circle Blvd., Corvallis, OR 97330, U.S.A.

European Headquarters
150, Route du Nant-D'Avril
P.O. Box, CH-1217 Meyrin 2
Geneva-Switzerland

HP-United Kingdom
(Pinewood)
GB-Nine Mile Ride, Wokingham
Berkshire RG11 3LL

Reorder Number
82483-90001 English

Printed in Singapore 7/84
82483-90003