

DIGITAL MAGNETIC TAPE UNIT



OPERATING AND SERVICE MANUAL

DIGITAL MAGNETIC TAPE UNIT

Model 7970A



SERIAL NUMBERS

This manual applies only to Tape Units
identified with Serial Number Prefix 1016A

07970-90620

PRINTED: JULY 1970

HEWLETT  PACKARD

JULY 1970

HP Computer Museum
www.hpmuseum.net

For research and education purposes only.

TABLE OF CONTENTS

Section		Page
I	GENERAL INFORMATION	
1-1.	Introduction	1-1
1-4.	Tape Unit Application	1-1
1-6.	Equipment Description	1-1
1-8.	Transport	1-4
1-10.	Rear Panel Components	1-4
1-13.	Head Assembly	1-4
1-19.	Write Enable Assembly	1-11
1-21.	Density Select	1-11
1-23.	Address Select	1-11
1-25.	Single-Multiple Unit Operation	1-13
1-27.	Manual-Remote Control	1-13
1-29.	Parity (Option)	1-13
1-31.	Functional Description	1-13
1-32.	Power Supplies	1-13
1-36.	AC Power Receptacle	1-14
1-38.	Motion Control	1-14
1-42.	Data Electronics	1-18
1-47.	Built-in Service/Self-Test Feature	1-23
1-49.	Dynamic Braking	1-24
1-51.	Options	1-24
1-53.	Accessories Furnished	1-24
1-55.	Accessories Available	1-25
1-57.	Special Instruments	1-25
1-59.	Equipment Identification	1-26
1-61.	Specifications	1-26
1-63.	Instruments Covered by This Manual	1-26
II	INSTALLATION	
2-1.	Incoming Inspection	2-1
2-2.	Mechanical Check	2-1
2-4.	Claims for Damage	2-1
2-6.	Site Selection	2-1
2-8.	Ventilation	2-1

TABLE OF CONTENTS (Continued)

Section	Page
2-10. Altitude	2-2
2-12. Mounting Instructions	2-2
2-14. Single-Unit - Multi-Unit Installation	2-2
2-16. Installation Performance Checks	2-2
 III OPERATION	
3-1. Introduction	3-1
3-5. Operating Controls and Indicators	3-1
3-7. Selection and Care of Tape	3-1
3-8. Tape Selection	3-1
3-10. Care of Magnetic Tape	3-1
3-12. Tape Storage	3-7
3-14. Installation/Removal of Write Enable Ring	3-7
3-16. Tape Reel Installation	3-7
3-18. Tape Threading Procedure	3-7
3-20. On-Line Read Only Operation	3-10
3-22. On-Line Write-Read Operation	3-10
3-24. Manual Operation	3-10
3-26. Rewind	3-11
3-28. Restart After Power Failure	3-11
3-30. REV, FWD, and +160 Capstan Servo Toggle Switches	3-11
3-32. Installation of BOT and EOT Photosense Tabs	3-12
 IV OPERATOR'S CHECKOUT PROCEDURES	
4-1. Introduction	4-1
4-4. Off-Line Performance Checks	4-1
4-5. Mechanical Check	4-1
4-7. Motion Control Checkout Procedure	4-2
 V OPERATOR MAINTENANCE	
5-1. Introduction	5-1
5-3. Preventive Maintenance	5-1
5-5. Eight-Hour Routine Cleaning and Check Procedure	5-1
5-7. Fuse Replacement	5-3
5-8. AC Line Fuses	5-3
5-10. Secondary Voltage Fuses	5-3

TABLE OF CONTENTS (Continued)

Section		Page
VI	PRINCIPLES OF OPERATION	
	To be supplied	6-1
VII	PERFORMANCE CHECKOUT	
	7-1. Introduction	7-1
	7-5. Off-Line Operation Test Equipment	7-1
	7-7. Test Environmental Conditions	7-2
	7-9. Special Test Procedure Considerations	7-2
	7-12. Equipment Requirements	7-2
	7-14. Electronic Test Equipment	7-3
	7-16. Tape Requirements	7-3
	7-18. Performance Checkout	7-3
	7-20. Preliminary Power Off Checks	7-4
	7-23. Operator Control Checks	7-5
	7-31. Service Switches and Accessories	7-7
	7-34. Tape Path Evaluation	7-7
	7-36. Power Supply Voltages	7-8
	7-40. Tape Speeds and Capstan Servo Adjustment	7-8
	7-55. Transport Function, Motion and Status	7-14
	7-61. Read Data Electronics	7-16
	7-69. Write Data Electronics	7-20
	7-80. Data Transfer Characteristics	7-25
VIII	ADJUSTMENT, ALIGNMENT, AND CALIBRATION	
	8-1. Adjustment Procedures	8-1
	8-3. Equipment Requirements	8-1
	8-7. Transport Mechanical Adjustments	8-2
	8-17. Regulated Power Supplies Adjustment	8-5
	8-20. Capstan Servo Electrical Adjustment	8-5
	8-30. Read Data Electronics Adjustments	8-9
	8-37. Write Data Electronics Adjustment	8-12
	8-40. Write Parity Adjustments	8-13
	8-42. Read Parity Adjustments	8-13
	8-44. Alignment Procedure	8-13
	8-46. Calibration Procedure	8-13



TABLE OF CONTENTS (Continued)

Section		Page
IX	TROUBLESHOOTING	
	To be supplied	9-1
X	REPAIR AND REPLACEMENT	
	To be supplied	10-1
XI	REPLACEABLE PARTS	
	11-1. Introduction	11-1
	11-4. Group Assembly Parts List	11-1
	11-6. Figure and Index Number.	11-1
	11-8. Part Number	11-1
	11-10. Description	11-1
	11-13. Units Per Assembly	11-2
	11-15. Ordering Information	11-2
XII	DIAGRAMS	
	To be supplied	12-1

LIST OF ILLUSTRATIONS

Figure		Page
1-1	7970A Digital Magnetic Tape Unit	1-0
1-2	7970A Digital Magnetic Tape Unit, Major Assemblies.	1-2
1-3	7970A Digital Magnetic Tape Unit, Bottom Rear Access Panel View.	1-3
1-4	Tape Deck Mainframe (Back Side).	1-5
1-5	Interior View, Left Panel	1-6
1-6	Rear Panel, Interior View	1-7
1-7	Power Supply, Access Door Open	1-8
1-8	Rear Panel, Bottom Section Removed	1-9
1-9	Head Assembly	1-10
1-10	Write Enable Assembly	1-12
1-11	Power Supply, PCB	1-15
1-12	Power Regulator Simplified Block Diagram.	1-16
1-13	AC Line Fuses	1-17
1-14	Simplified System Block Diagram	1-19
1-15	Capstan Servo Simplified Schematic.	1-21
1-16	Reel Servo PCB.	1-22
2-1	Read Data, Write Data, and Motion Control/Status Connectors.	2-3
3-1	Controls and Indicators	3-2
3-2	Write Enable Ring Removal-Installation.	3-8
3-3	Tape Threading	3-9
3-4	Installation of Photosense Tabs.	3-13
8-1	Start/Stop Time	8-8
11-1	Model 7970A Digital Magnetic Tape Unit.	11-3
11-2	Tape Deck Assembly.	11-7
11-3	Cabinet Assembly.	11-13
12-1	Photosense Head Assembly (A2), Schematic	12-2
12-2	Tension Arm (A3/A4) Schematic	12-3
12-3	Reel Servo (A7) Schematic	12-4
12-4	Capstan Servo (A9) Schematic.	12-5
12-5	Write Enable Assembly (A10) Schematic.	12-6
12-6	Control Switch (A11A1) Schematic	12-7

LIST OF ILLUSTRATIONS (Continued)

Figure		Page
12-7	Density Select (A12A1)	12-8
12-8	Unit Select (A13A1) Schematic	12-9
12-9	Write Head Interconnect (A14) Schematic	12-10
12-10	Read Head Preamplifier (A15) Schematic	12-11
12-11	Motion Control (A16) Schematic	12-12
12-12	Write Interconnect (A17) Schematic	12-13
12-13	Write Control (A17A1) Schematic	12-14
12-14	Write Data (A17A2 thru A6) Schematic	12-15
12-15	Read Interconnect (A18) Schematic	12-16
12-16	Read Control (A18A1) Schematic	12-17
12-17	Read Data (A18A2 thru A18A6) Schematic	12-18
12-18	Transformer (A19A1) Schematic	12-19
12-19	Power Supply (A19) Schematic	12-20
12-20	Power Regulator (A19A3) Schematic	12-21
12-21	Intercabling Diagram for 7970	12-22

LIST OF TABLES

Table		Page
1-1	Motion Control Flip Flops	1-20
1-2	Specifications	1-27
2-1	Motion Control/Status Connector, Description of I/O Lines	2-7
2-2	Read Data Connector, Description of I/O Lines	2-11
2-3	Write Data Connector, Description of I/O Lines	2-12
5-1	Operator Preventive Maintenance Schedule	5-3
7-1	Bit-to-Bit Distances	7-2



7970-A-2

Figure 1-1. 7970A Digital Magnetic Tape Unit

SECTION I

GENERAL INFORMATION

1-1. INTRODUCTION

1-2. The 7970A Digital Magnetic Tape Unit, Operating and Service Manual contains operator instructions and complete service data for the 7970A Digital Magnetic Tape Unit. For Off-Line application, the 7970A Operating and Service Manual data will be adequate unless special features are ordered. In those cases, manual supplements will be supplied.

1-3. The three interface connector boards are manufactured with parallel connectors (control/status, write data, and read data) which allows up to four tape units to be utilized from one controller. Three female mating connectors are supplied, each have a 48-pin (24 active line) capability. These connectors enable the user to make direct connections with his interfacing cables.

1-4. TAPE UNIT APPLICATION

1-5. The Hewlett-Packard, Model 7970A, Digital Magnetic Tape Unit is a low speed tape recorder designed for small computer On-Line applications and miscellaneous applications such as plotting table control, key edit system, microfilm storage, library programs, etc.

1-6. EQUIPMENT DESCRIPTION

1-7. The Unit is housed in a box-frame constructed of brake-formed sheet. The side panels are brake-formed to permit rack mounting. Top and bottom panels are perforated sheet for convection cooling. The rear paneling consists of three panels: top panel has access for interface cabling; the middle panel is plain and fixed; the bottom panel is perforated for cooling and removable for access to power supply components. The tape deck mainframe is hinge-connected to the left-side panel and latched to the right-side panel. A cover door (swings right), attached to the main casting, protects tape area. See figures 1-2 and 1-3.

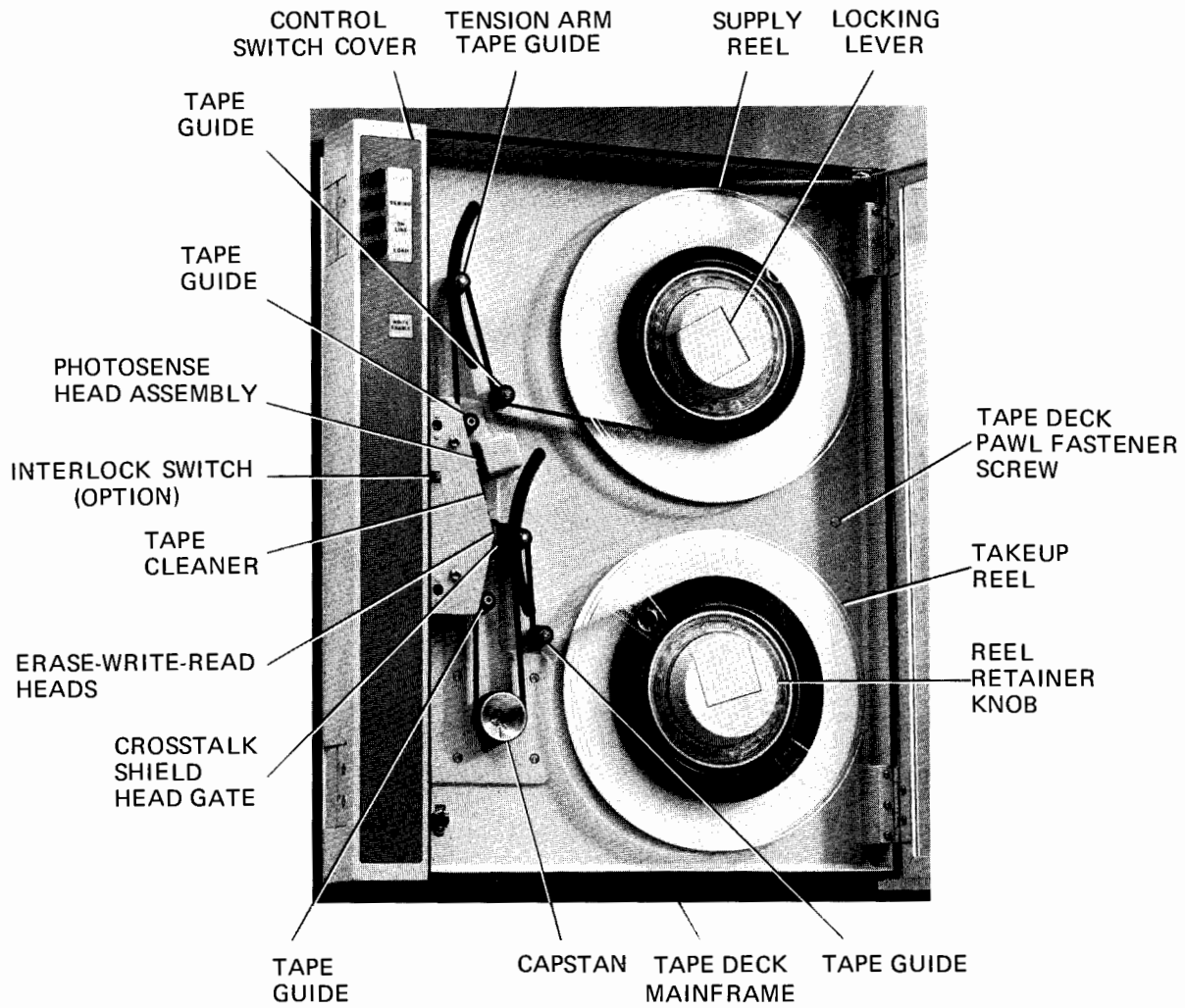

7970-A-3

Figure 1-2. 7970A Digital Magnetic Tape Unit, Major Assemblies



FIXED
CENTER-REAR
PANEL

BOTTOM REAR
ACCESS DOOR

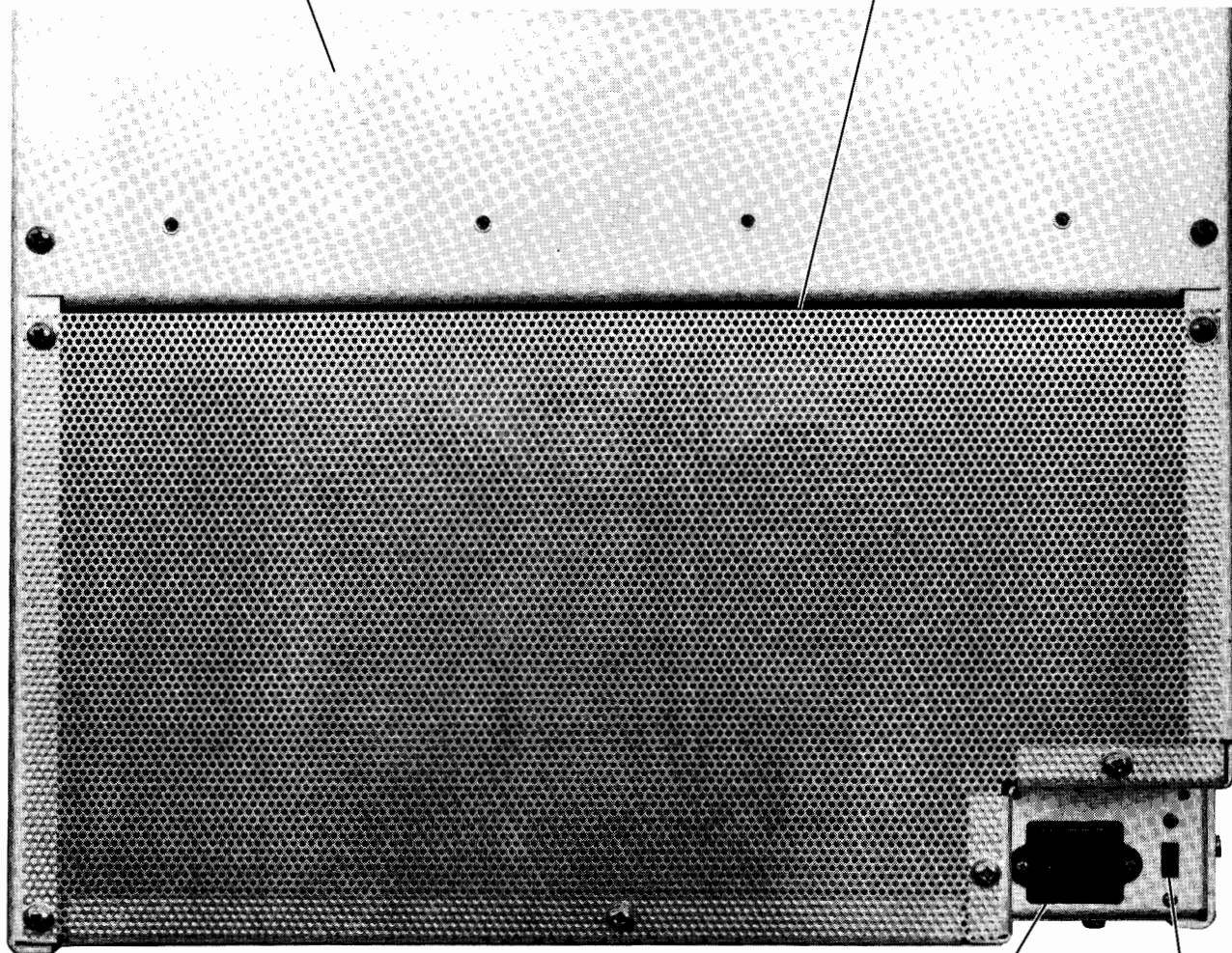

AC POWER
RECEPTACLE

115-230 VAC
SLIDE SWITCH

7970-A-4

Figure 1-3. 7970A Digital Magnetic Tape Unit, Bottom Rear Access Panel View

1-8. Transport

1-9. Transport components are all mounted to the main casting with the exception of the motion control card which is mounted to the upper portion of the left-side panel (viewer facing control panel). See figures 1-4 and 1-5. The control panel, reel hubs, write-read heads, photosensing assembly, tape cleaner, erase head, and tape path components are located on the front of the tape deck mainframe. The write enable assembly, tape deck panel fastener, reel motors/reel servo PCB, tension arm assemblies, capstan servo assembly/capstan servo PCB, and the cover door interlock switch (option) are attached to the interior-side of the main casting.

1-10. Rear Panel Components

1-11. The interior, rear panel houses the write-read data modules, the power supply, and the AC fuse receptacles. The power supply regulated/unregulated cards are attached to the front-side of the power supply access door. The unregulated card is mounted to the access door parallel to the rear panel; the regulated card is mounted to the unregulated card, parallel to the right-side panel. See figure 1-6. The ± 20 V filter capacitors, +10 V filter capacitors, the output transistors' heat sink, and the ± 40 V resistors are attached to the innerside of the power supply access door. See figure 1-7.

1-12. The bottom section of the rear panel may be removed to gain access to the power transformer, the rectifier bridges, and the AC power connection. See figure 1-8.

1-13. Head Assembly

1-14. The head assembly (depending upon options) consists of a write head stack, read head stack, erase head, two tape guides, crosstalk shield head gate, and a base plate. See figure 1-9.

1-15. The two tape guides are used to assure proper positioning and control of tape as it passes over the heads. Before reaching the heads, tape passes over a slotted, block type cleaner which removes any foreign particles. To assure high reliability recording, tape is erased by high-density, full tape width erase head just before it reaches the write head. The head assembly is IBM compatible.

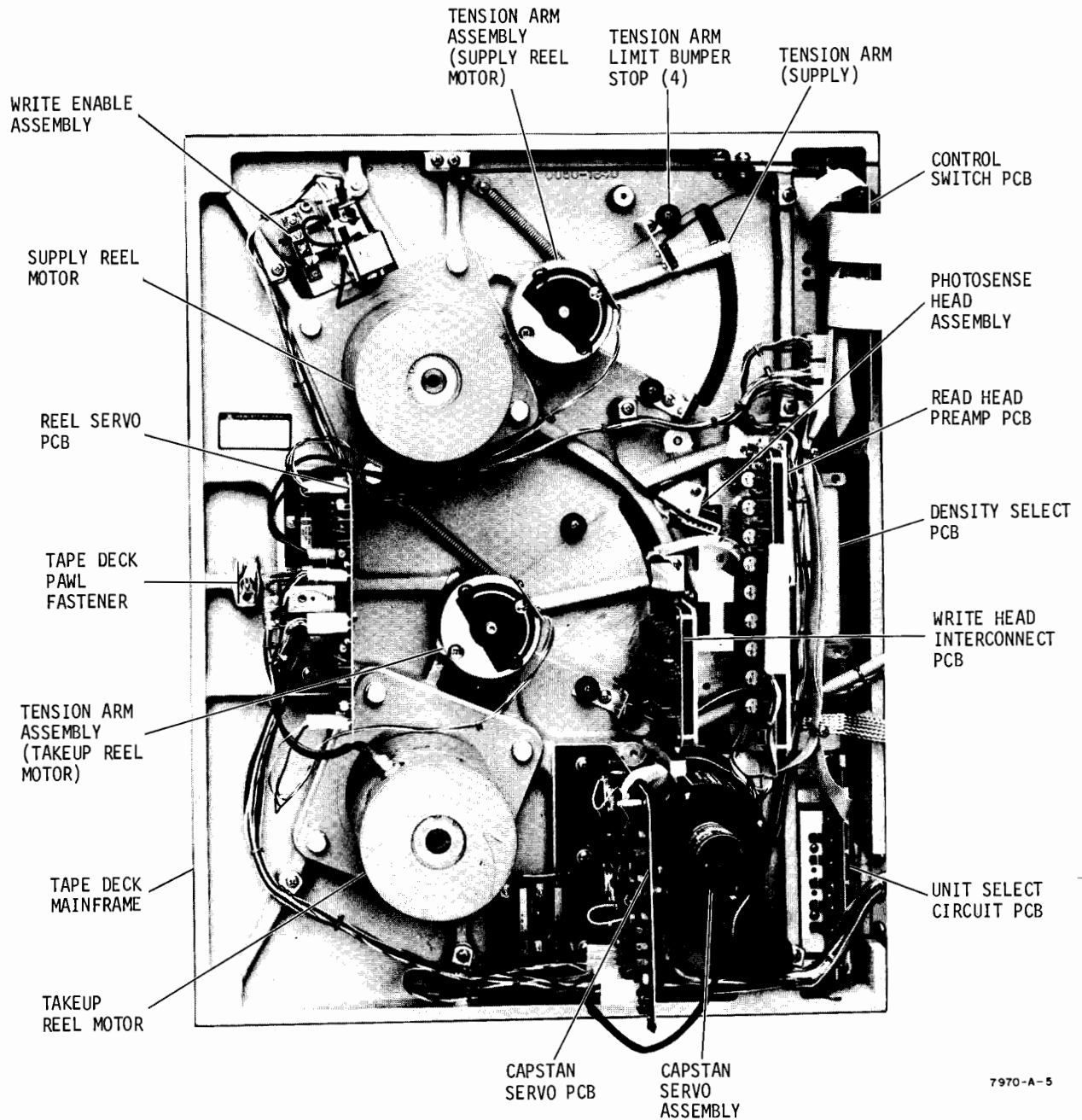

7970-A-5

Figure 1-4. Tape Deck Mainframe (Back Side)

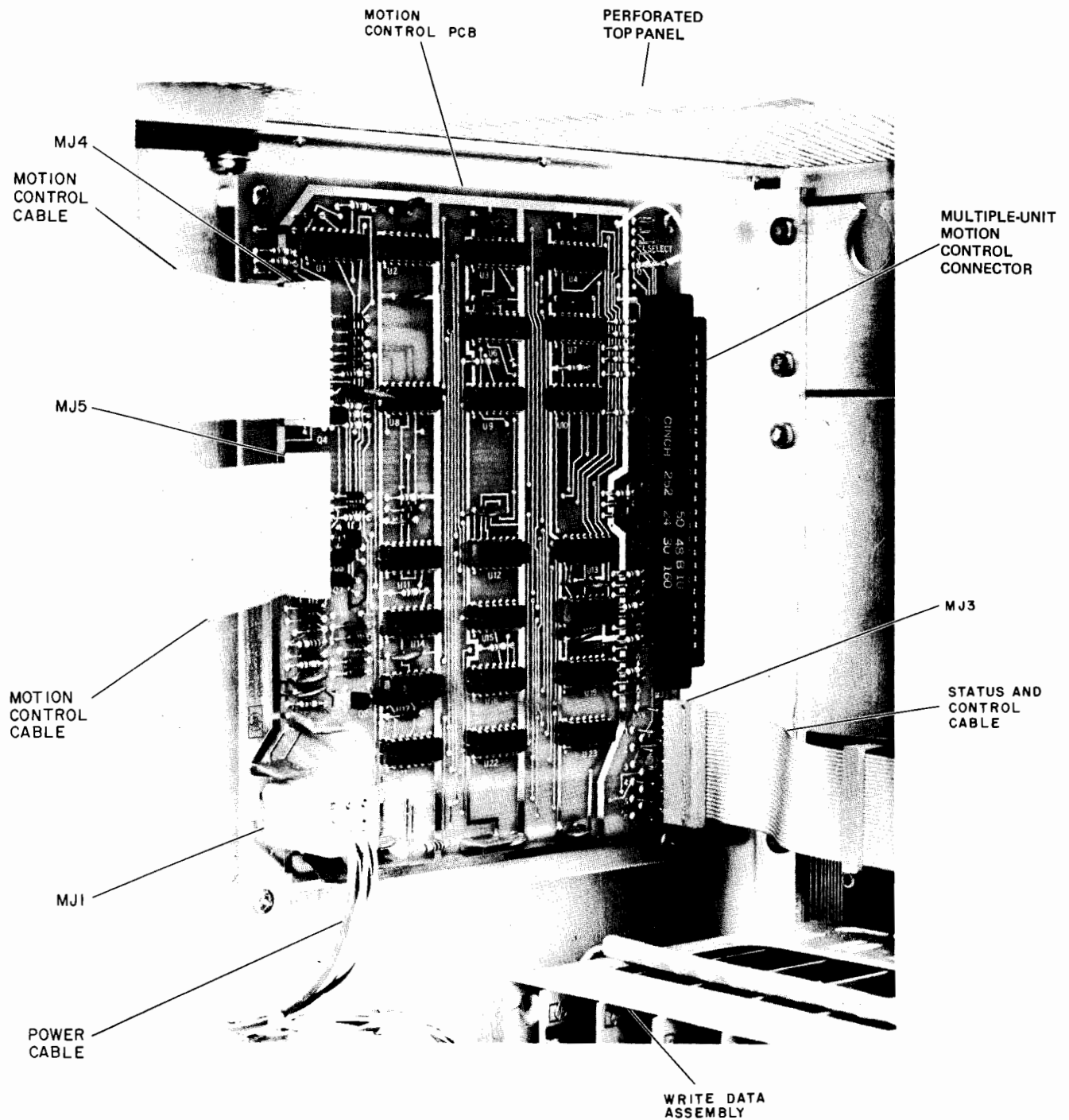
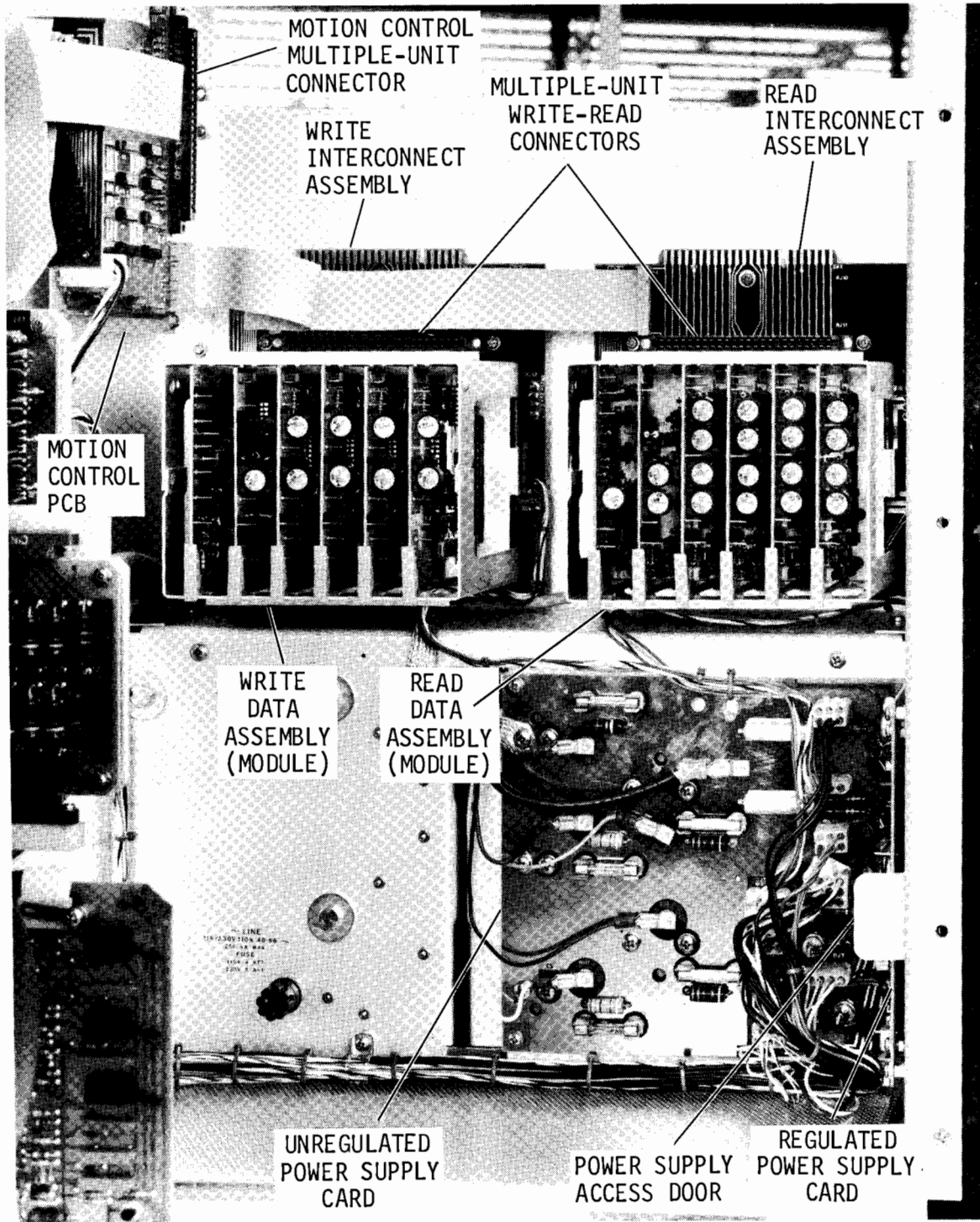

Figure 1-5. Interior View, Left Panel

Add NOTE: Tape Unit equipped for 9-Channel Write-Read operation



7970-A-7

Figure 1-6. Rear Panel, Interior View

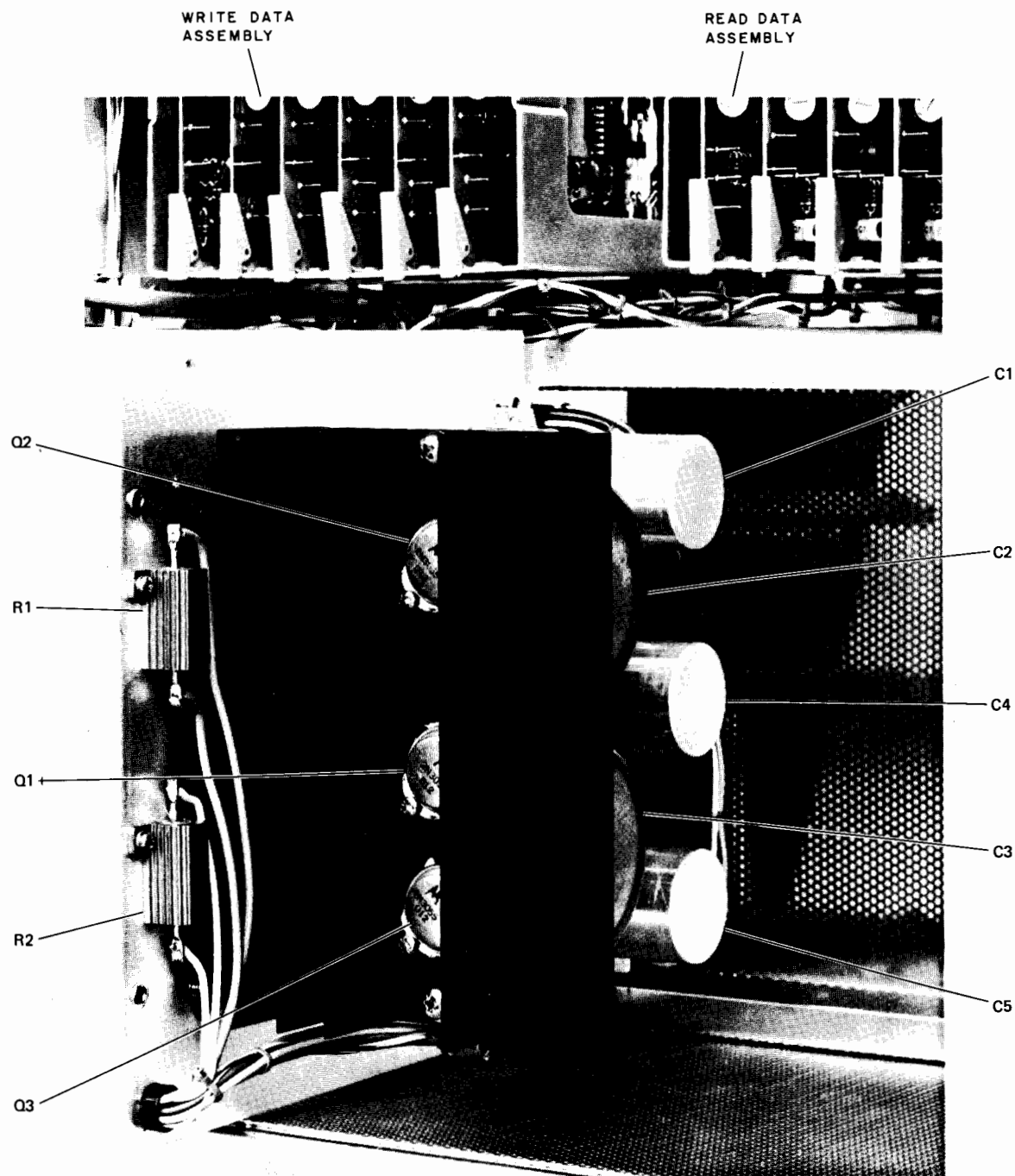

7970-A-8

Figure 1-7. Power Supply, Access Door Open

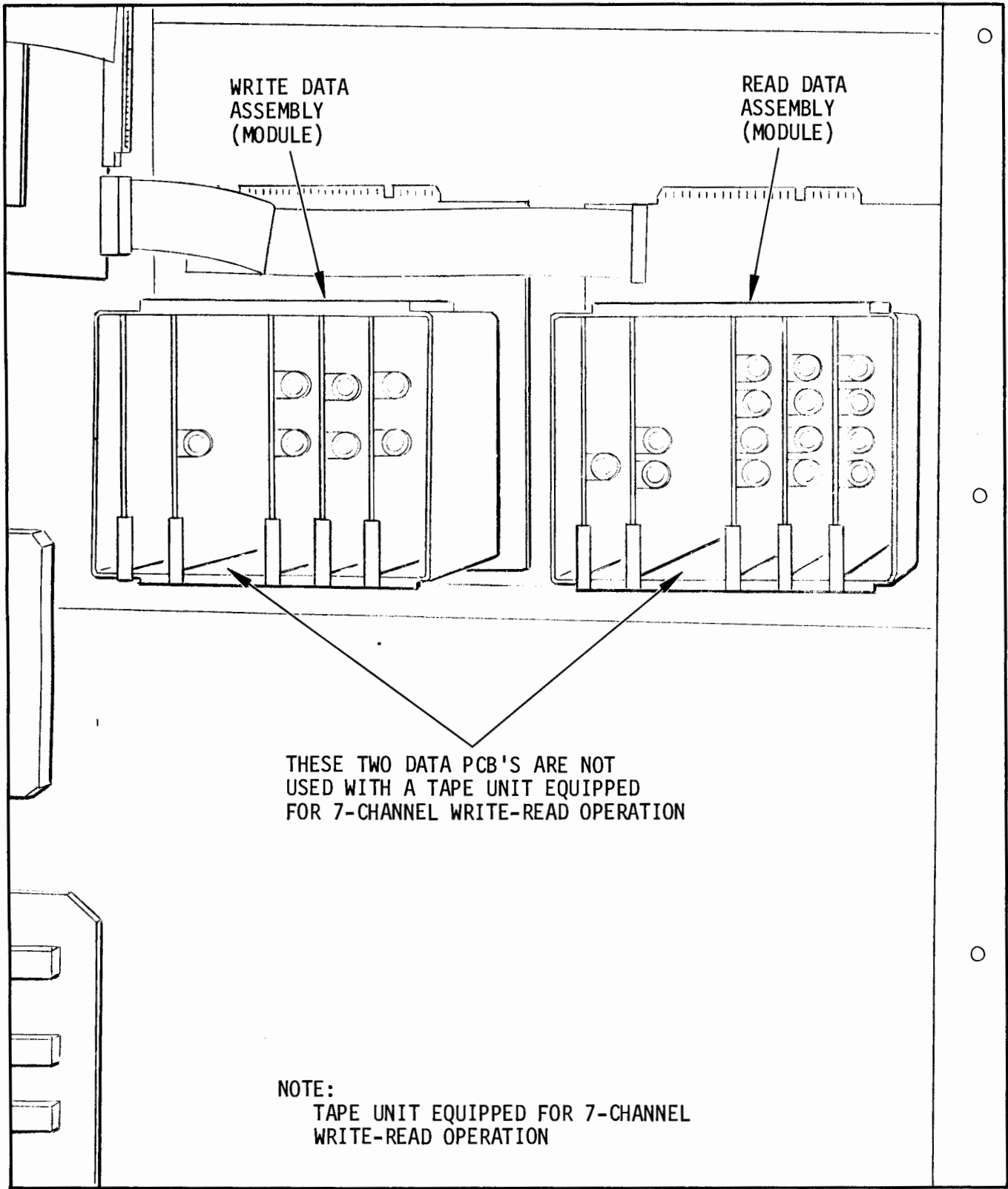
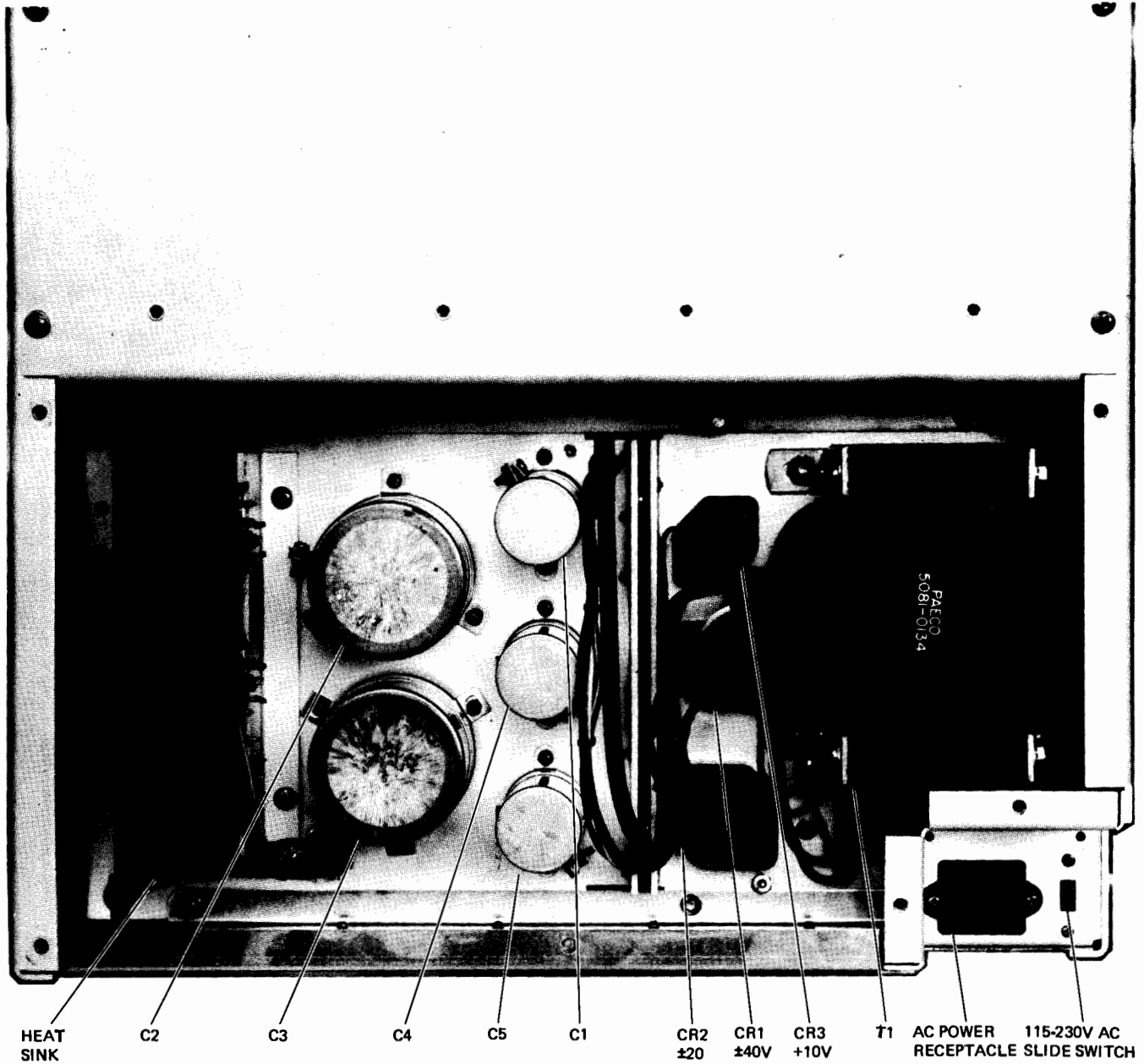
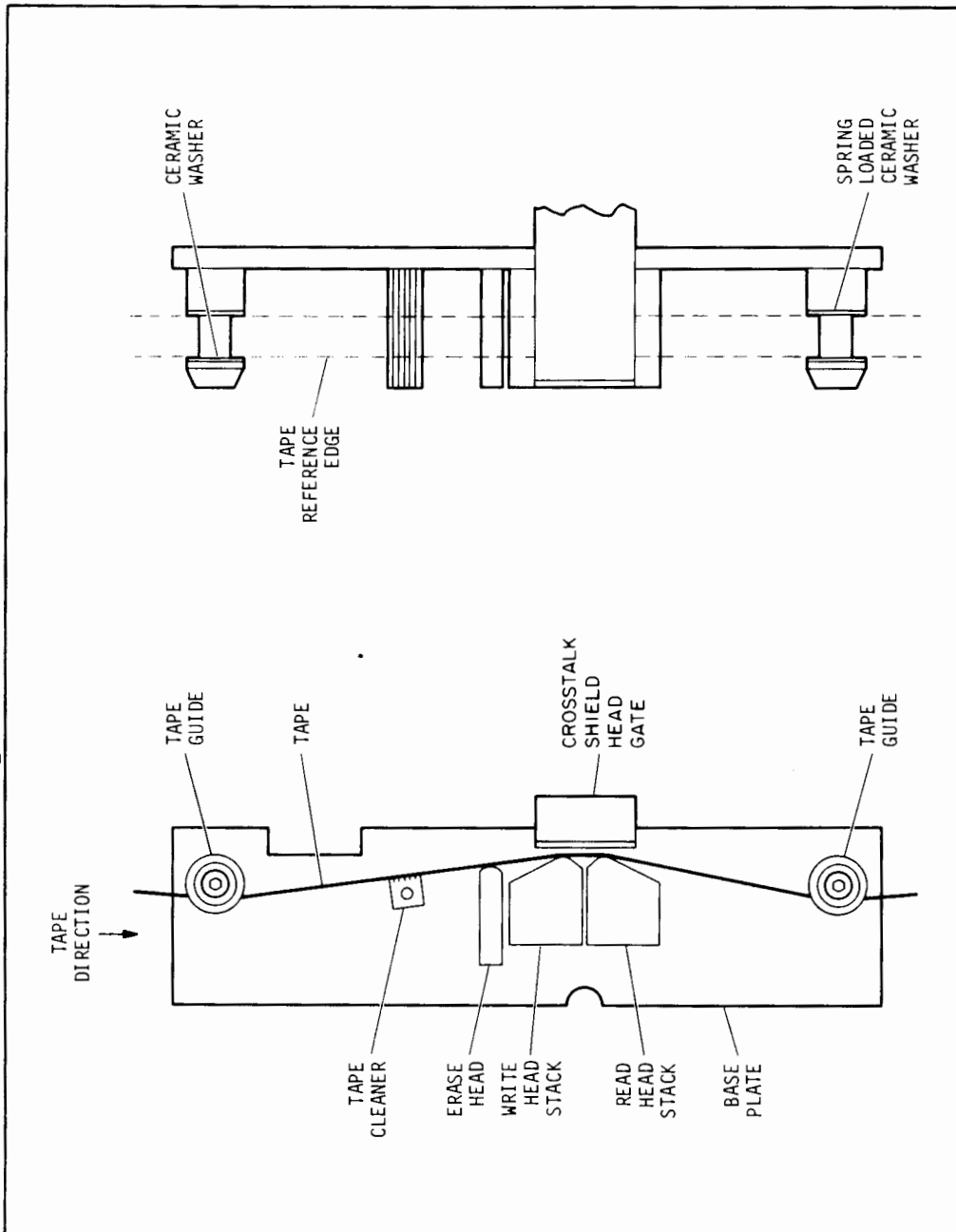

Figure 1-6a. Rear Panel, Interior View



7970-A-9

Figure 1-8. Rear Panel, Bottom Section Removed



7970 - A-10

Figure 1-9. Head Assembly

1-16. The write-read heads are 7- or 9-track, NRZI standard format types which will handle tape packing densities of 200, 556, and 800 bpi within a tape speed range of 10 to 37-1/2 ips.

1-17. A crosstalk shield head gate, positioned directly over the write-read heads, reduces write head to read head crosstalk during the write operation.

1-18. Channel scrambling is accomplished in the head cable on 9-track systems. From the reference edge, the 9-track channel designation is 5, 7, 3, P, 2, 1, 0, 6, and 4. Seven-track channel designation from the reference edge is 1, 2, 3, 4, 5, 6, and 7. Channel 7 is used for Parity (Odd or Even). The track channel designation is IBM compatible. Reference edge refers to outside tape edge (edge closest to operator).

1-19. Write Enable Assembly

1-20. The Write Enable assembly is part of the write option package. See figures 1-4 and 1-10. The complete unit consists of the mechanical assembly, the Control Panel cover, Control Panel indicator, and the Write Enable ring (provided by the tape supplier) which is installed in the supply reel. See figures 3-1 and 3-2. The Write Enable ring must be installed to establish write enable condition. The WRITE ENABLE indicator is illuminated when the supply reel, fitted with a write enable ring, is installed on the supply reel hub. For read only operation, the write enable ring is removed. This results in a file protect status during which no data can be inadvertently written on the tape during a read operation.

1-21. Density Select

1-22. Density Select is an option feature which is applicable to the read function. Standard units are hard-wired to write or read at a tape packing density of 800 bpi. Units equipped with the Density Select option permit the operator to select read densities of 200, 556, 800 bpi. The Density Select option includes a three-button, interlocked switch with indicators, a circuit card (which includes line drivers), and a Control Panel cover. The Density Select option is field installable. See figure 3-1.

1-23. Address Select

1-24. Address Select is an option feature which is intended for multiple unit operation under computer control. The option includes a five-button interlocked

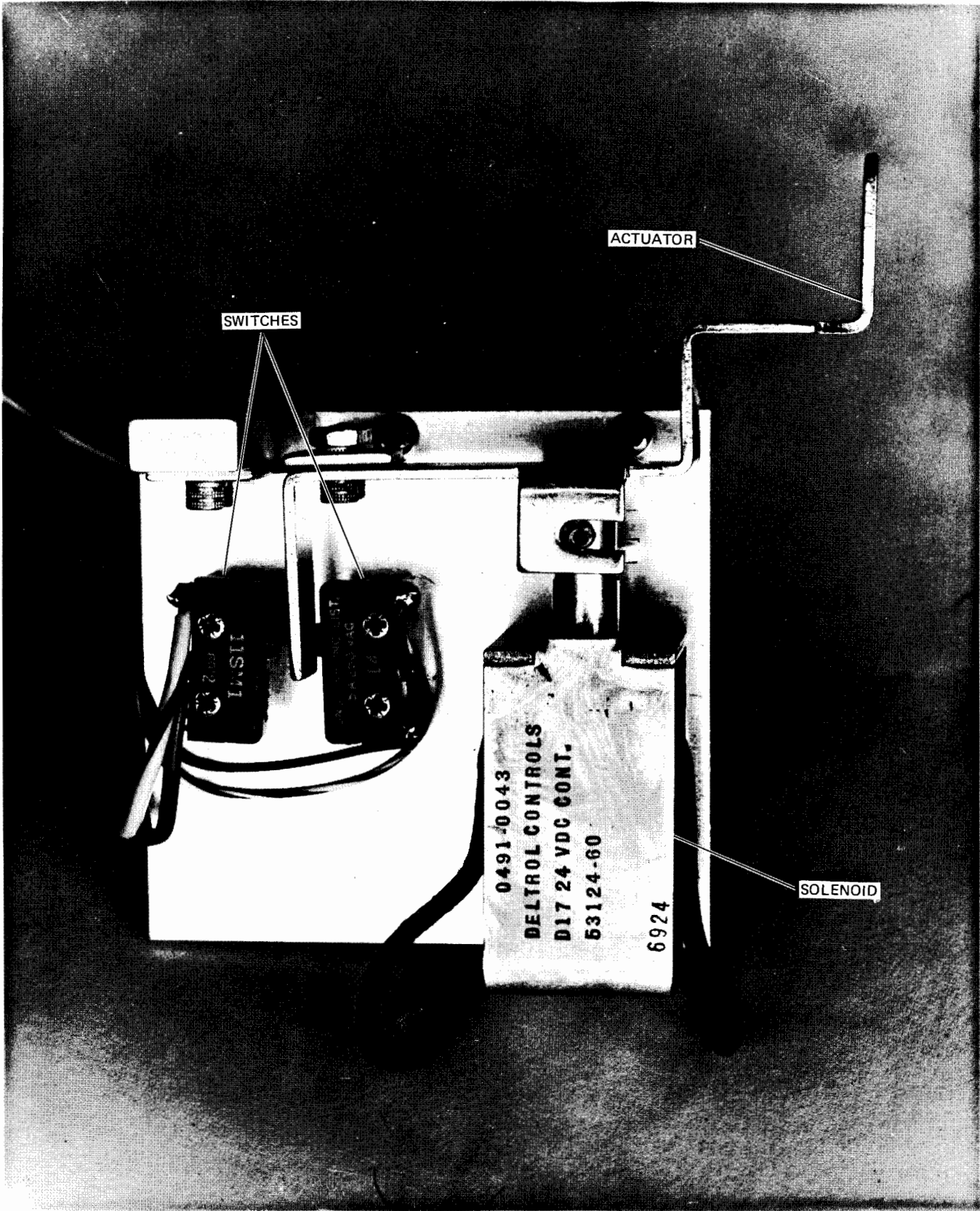

7970-A-11

Figure 1-10. Write Enable Assembly

switch with indicators, a circuit card, and a Control Panel cover. This unit is field installable.

1-25. Single-Multiple Unit Operation

1-26. The Motion Control PCB, the Write Interconnect Assembly and the Read Interconnect Assembly are factory equipped with parallel input/output connectors for multi-unit operation.

1-27. Manual-Remote Control

1-28. The tape unit is intended for remote controlled read-write data functions. Therefore, the Unit has a minimal number of manual controls. The manual controls are limited to power-up/power down, Reset, Rewind, On-Line, and Load functions. Option features allow the operator to make tape packing density selection for read operation, and to select Unit address for multiple unit operation.

1-29. Parity (Option)

1-30. To be supplied.

1-31. FUNCTIONAL DESCRIPTION

1-32. Power Supplies

1-33. The power supply is a basic, full-wave rectifier system. Transformer T1 and the bridge rectifiers provide $\pm 40V$, $\pm 20V$, and $+10V$ unregulated voltages. Solid state, bridge-type, diode rectifiers provide AC-DC rectification. RC filtering, with large capacitors, provide low ripple source voltages for the regulated and unregulated power supply cards. The transformer, and the rectifier bridges, are accessible with the lower-rear panel removed. See figure 1-8. The filter capacitors, the regulated series-pass transistors which are heat sink-mounted, and the $\pm 40V$ output resistors (R1 and R2) are mounted to the inner-side of the power supply access gate. See figure 1-7. The regulated and unregulated power supply cards are attached to the outside of the gate. See figure 1-6. The AC power receptacle is mounted to the inner wall of the power supply compartment.

1-34. The rectified voltages are fed to the unregulated power supply card for filtering, fusing, and distribution. The heavier, unregulated/regulated card

components are mounted to the power supply access gate as indicated in paragraph 1-33. The following transformer secondary fuses are mounted to the power supply PCB: +10V (3A), +20V (10A), +40V (2A, SB), -20V (10A); and -40V (2A, SB). Power input/output connectors for both regulated and unregulated voltages are provided on the unregulated card. See figure 1-11.

1-35. The power regulator PCB contains three regulators, the +12V, -12V, and the +5V, only the +12V regulator is adjustable. The -12V and the +5V supplies are referenced to the +12V supply. Also packaged on the power regulator PCB is the +20/40V switch and the -20/40V switch. The voltage switches provide 20 volts to the reel servos for normal speed operation and 40 volts for high speed operation, such as rewind or high speed forward search. All three regulators are fairchild-type, μ A-723, IC voltage regulators. The +12V regulator, the -12V, and +5V regulators use current limiting. In addition, there is a 7-volt crowbar circuit across the +5V supply to protect the IC logic from over-voltage conditions. See figure 1-12 for a simplified block diagram of the regulator power supply.

1-36. AC Power Receptacle

1-37. The AC power receptacle is located in the lower right-hand corner of the rear panel. A 115V-230V slide switch is provided so that the Unit can be used on 115V ($\pm 10\%$) or 230V ($\pm 10\%$) AC power. A built-in L-C filter provides protection from AC line transients. A 4 ATT fuse (2 ATT fuse for 230V operation) protects the transformer 115 VAC operation. See figure 1-13.

1-38. Motion Control

1-39. The basic function of the motion control card is to give commands to the capstan servo and to instruct the capstan servo to go forward or reverse at 25 ips, forward or reverse at 160 ips, or forward at 20 ips for load point search. The Motion Control card, in turn, gets its commands from the operator control panel with the unit off-line, or from a remote controller when the unit is on-line. The most complicated function is Rewind during which the motion control card tells the Capstan Servo to go at 160 ips in reverse. When the load point is sensed, the -160 command is removed and the Capstan Servo is told to load at +20 ips until the load point tab is again encountered. The motion control card also provides status signals to the data electronics that tell the data electronics whether or not the Write Enable ring is in place, what density has been selected, and the speed and direction

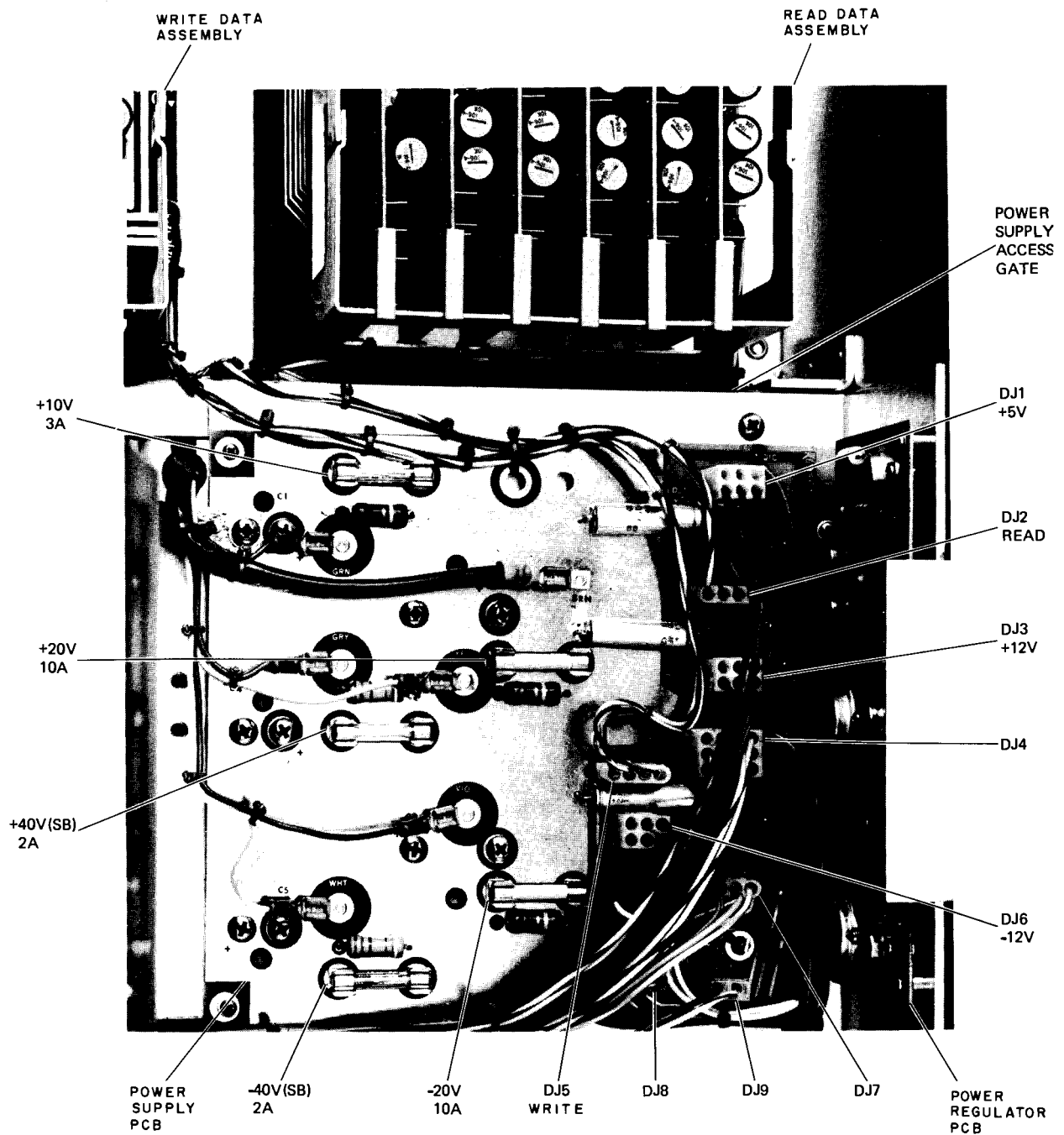

7970-A-12

Figure 1-11. Power Supply, PCB

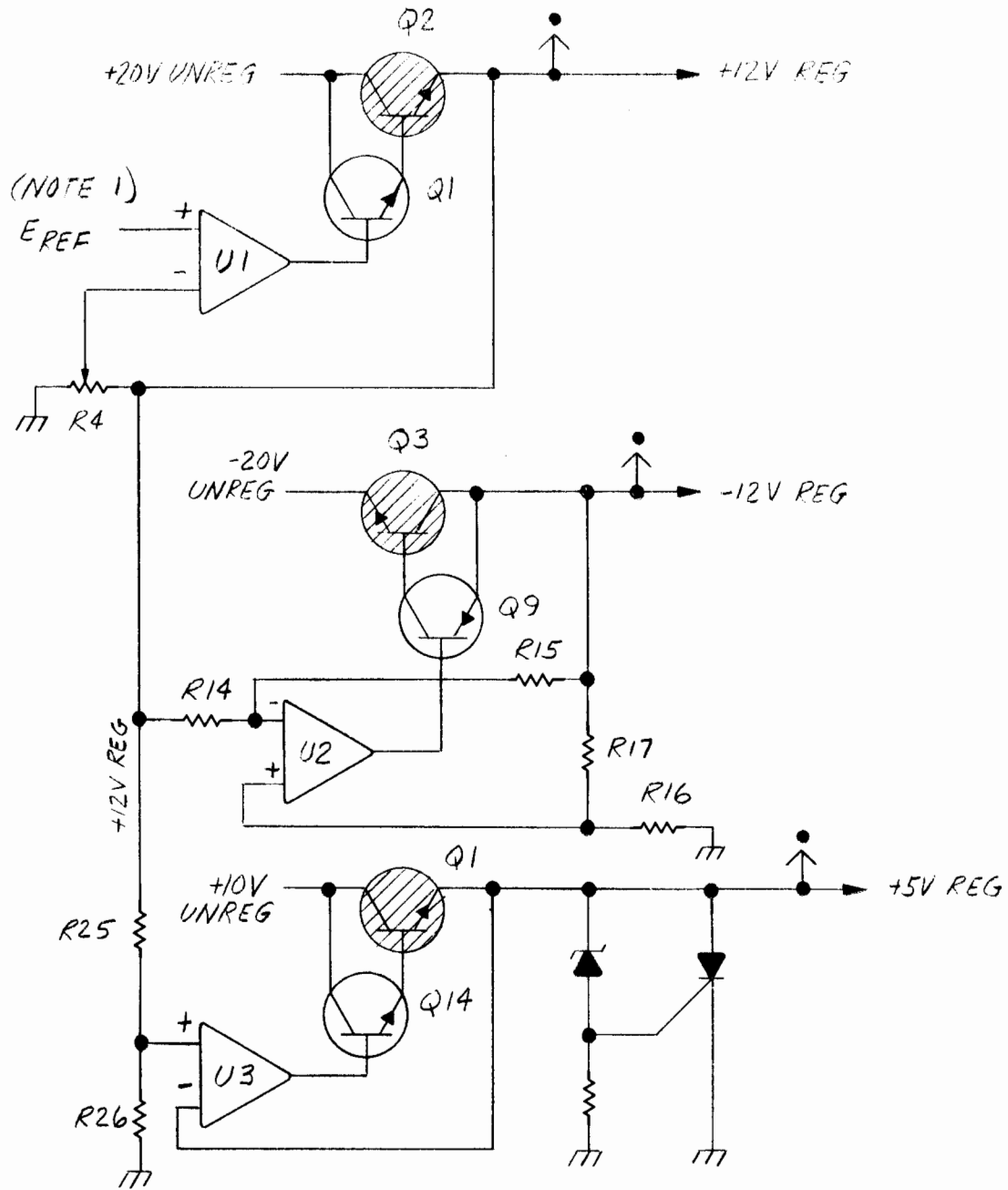

NOTES:

1. E_{REF} IS INTERNALLY GENERATED IN U1.
2. CURRENT FOLDBACK AND CURRENT LIMIT CIRCUITRY NOT SHOWN.
3.  = TRANSISTOR ON HEATSINK.

7970-A-13

Figure 1-12. Power Regulator Simplified Block Diagram

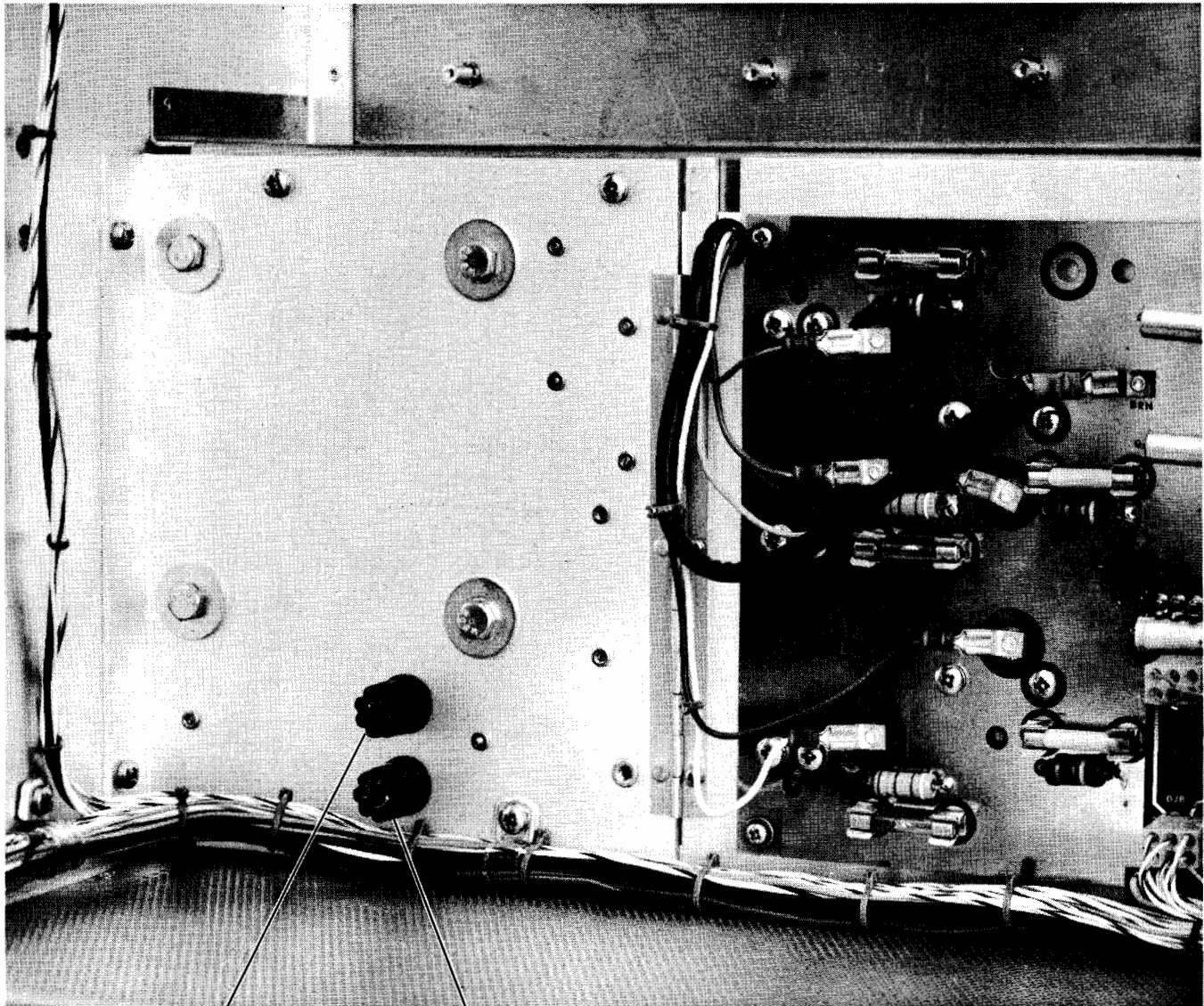

AC
LINE FUSE
115V
4 ATT

AC
LINE FUSE
230V
2 ATT

7970-A-58

Figure 1-13. AC Line Fuses

of tape motion. The motion control supplies Ready, Loadpoint, EOT, Rewind, SOL, and File Protect status to the controller. The controller can command the tape unit to go forward or reverse at high speed or normal speed, to rewind, or go off-line. See figure 1-14. As an aid to understanding motion control schematics, table 1-1 identifies the motion control flip-flops and describes their functions.

1-40. Capstan speed and direction are controlled by the Capstan Servo which consists of the Capstan Motor/tachometer combination and the Capstan Servo card. The servo employs current and velocity feedback. The velocity feedback is provided by a high-quality, magnetic moving coil tachometer attached to the capstan motor shaft. Current feedback is provided by a pair of sensing resistors (see figure 1-15, Capstan Servo Simplified Schematic) and a feedback resistor (R25). The capstan servo motion control commands are generated by a Rev/Fwd circuit, a HS Fwd/Rev circuit, and a Load circuit.

1-41. The Reel Servo system consists of the tension arm assemblies, the reel servo card, and the reel motors. The photoresistive cell generates a voltage that is proportional to the direction and magnitude of the tension arm movement. A summing circuit in the reel servo card presents a positive- or negative-going voltage to preamps U1 or U2. The preamp output is fed to power amplifiers; the polarity will determine the direction of tape movement. A positive-going voltage from the preamps will drive the tape forward. A negative-going voltage will drive the tape in reverse. ± 20 volts supplied to the reel servo by the regulated power supply provides normal forward-reverse reel motor operation; ± 40 volts supplied to the reel servo provides high speed forward-reverse reel motor operation. The $+20/40V$ and the $-20/40V$ switching functions which occur in the regulated power supply are controlled by motion control PCB logic initiated by panel control switches or by processor commands. See figure 1-16.

1-42. Data Electronics

1-43. Data is recorded (written) on 1/2" computer grade magnetic tape, on 7- or 9-tracks, depending upon head and logic options. The 7970A uses NRZI (Non-Return To Zero) IBM compatible recording technique at densities of 200, 556, or 800 bpi. Write equipped units will have optional read-after-write capability for error-checking option features. If the unit is not equipped with the Density Select option, the logic will be factory hard wired for 800 bpi. However, the unit can be

7970-A-14

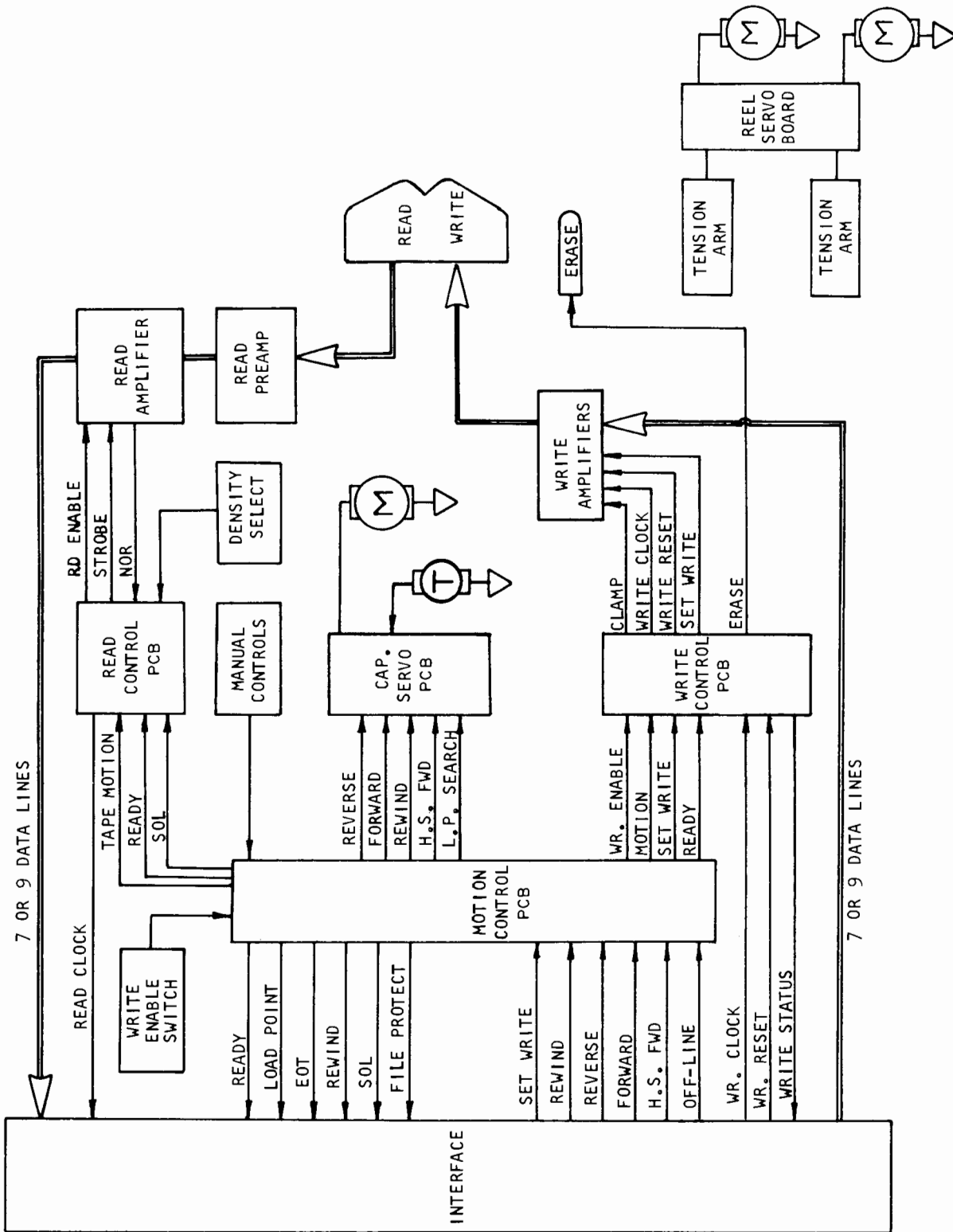
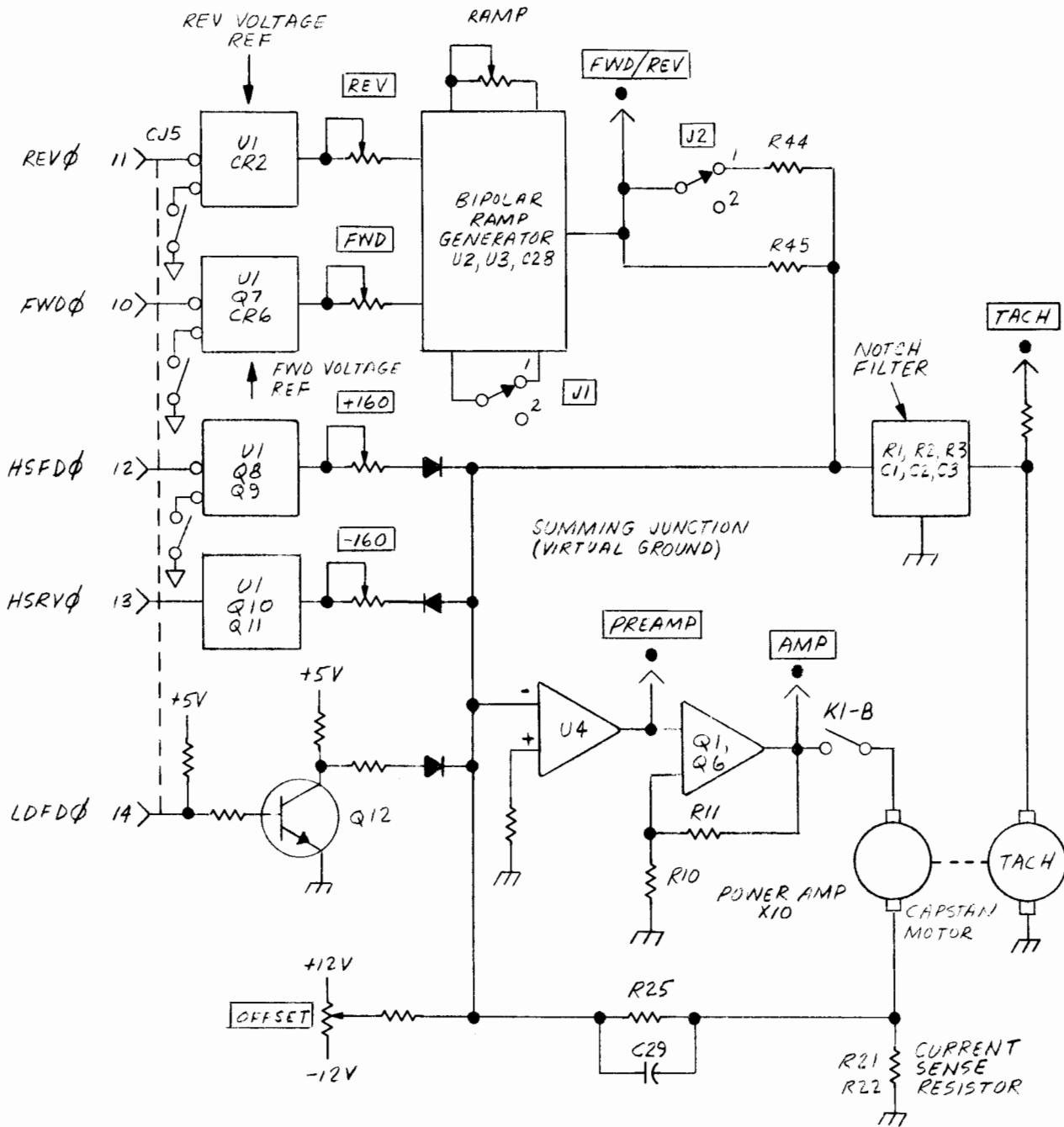

Figure 1-14. Simplified System Block Diagram

Table 1-1. Motion Control Flip Flops

NAME	DESIGNATION	COMMENTS
CONTROL	ONLN 1D - 2B	Set by ON LINE PB, reset by RESET PB.
	LDFD 12A	Commands forward motion of +20 ips.
	COMP 12B	Load sequence complete and T.U. not rewinding.
	NRWD 6B	Commands - 160 ips when reset. Normally in set state.
	SRWD 4B - 3A	Rewind status. Remains set during rewind and during the load point search that automatically follows a rewind operation.
EOT LOGIC	DIR 22A - 22B	Remembers last direction T.U. moved.
	SEOT 17B	EOT status. Set or reset depending on direction of tape travel when EOT tab. Encountered.
SHAPING	LDPB 2A - 1A	Anti-bounce for load switch.
	LP 6A	Squares up LP amp.
	EOT 17A	Squares up EOT amp.



7970-A-15

Figure 1-15. Capstan Servo Simplified Schematic

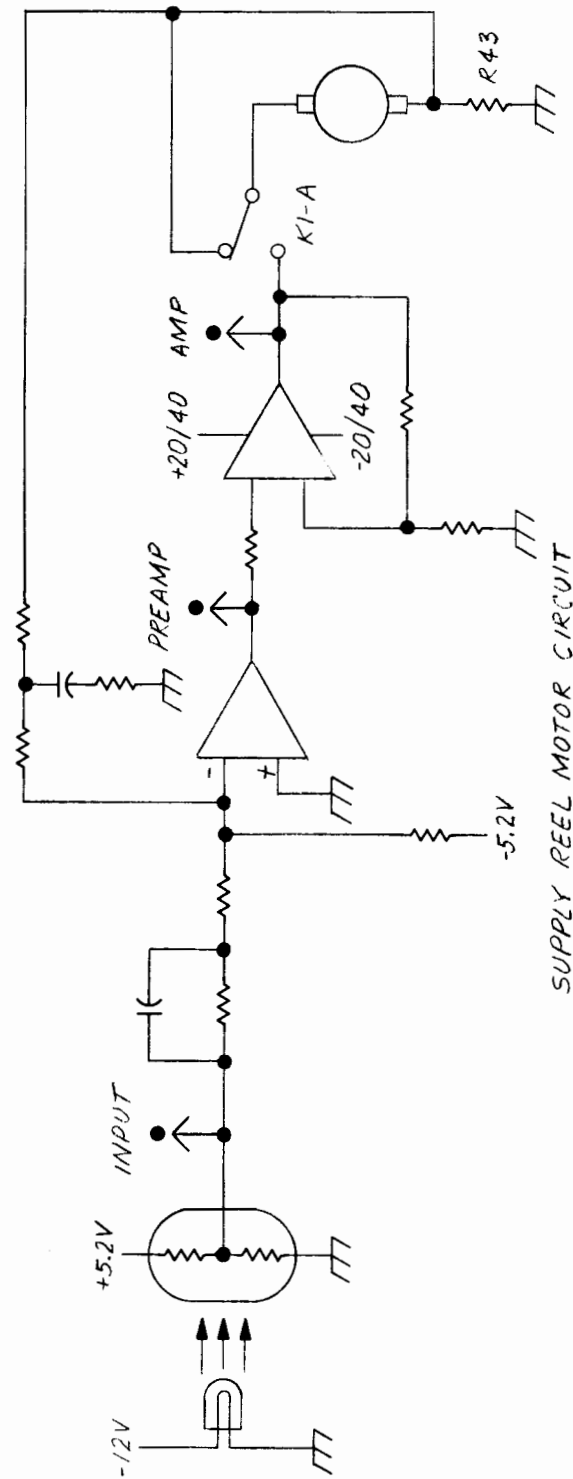
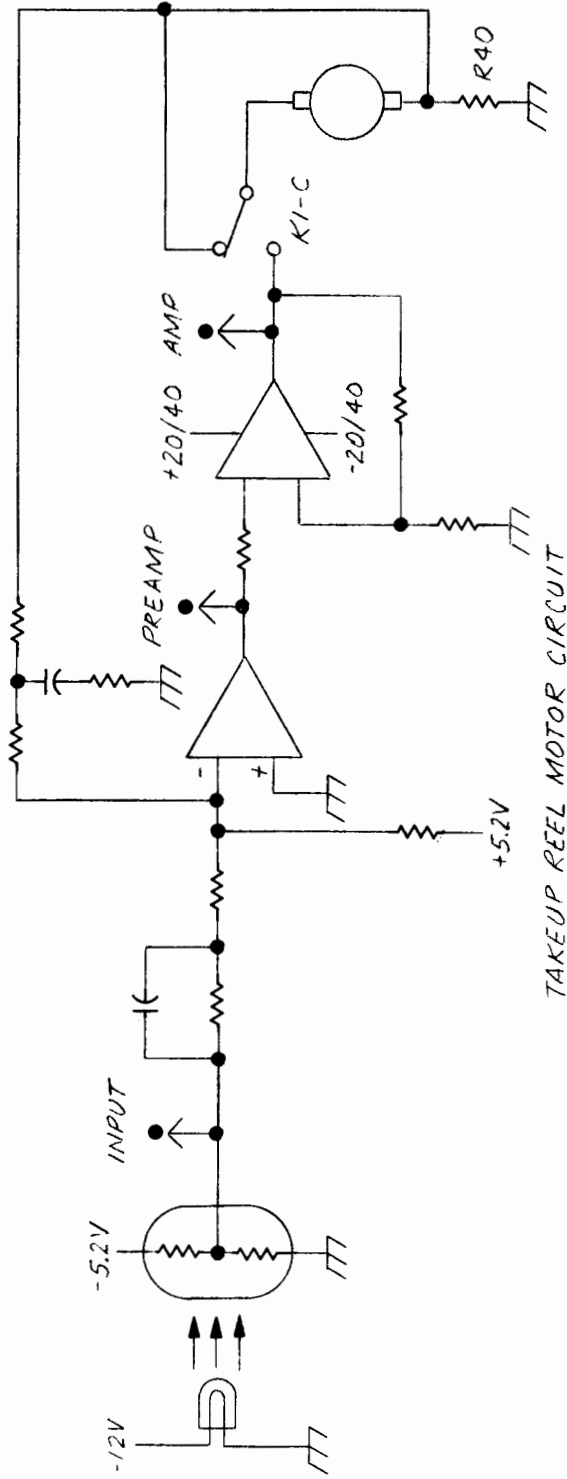

7970-A-16

Figure 1-16. Reel Servo PCB

used for calibration procedures, adjustment procedures, and service procedures. Using the Capstan Card switches, a complete write/read adjustment procedure can be performed with the recommended test equipment. As a service feature, motion control failures can be isolated to the Motion Control card or the Capstan Servo card.

1-49. Dynamic Braking

1-50. Dynamic braking is a method of stopping a DC motor by converting the DC motor to a generator in order to dissipate power in the DC motor system. In the 7970A, in any power-off condition, relay K1 switches back to its normal state, which shorts the reel motor armatures and establishes the generator counter-emf which opposes DC motor torque. See figure 1-16.

1-51. OPTIONS

1-52. Options for the Hewlett-Packard 7970A Digital Magnetic Tape Unit are fully field installable, but will usually be customer modifications stipulated, at the time of purchase, and installed at the factory. The following options are available:

- a. Write/Read data electronics.
- b. Read Only data electronics.
- c. Triple Density selection: 200, 556, and 800 bpi.
- d. Unit Address (0, 1, 2, and 3) for multi-unit operation.
- e. Seven or Nine Tracks Read Only Head Stack.
- f. Seven or Nine Tracks Write/Read Head Stack.
- g. Parity Check/Generate.
- h. Cover Door Interlock Switch.

1-53. ACCESSORIES FURNISHED

1-54. The following accessories are furnished with the standard 7970A Tape Unit:

<u>QTY</u>	<u>ITEM</u>
3	Input/Output Connectors with hoods and hardware (Control & Status, Write Data, & Read Data)
1	Left Mounting Bracket

used for calibration procedures, adjustment procedures, and service procedures. Using the Capstan Card switches, a complete write/read adjustment procedure can be performed with the recommended test equipment. As a service feature, motion control failures can be isolated to the Motion Control card or the Capstan Servo card.

1-49. Dynamic Braking

1-50. Dynamic braking is a method of stopping a DC motor by converting the DC motor to a generator in order to dissipate power in the DC motor system. In the 7970A, in any power-off condition, relay K1 switches back to its normal state, which shorts the reel motor armatures and establishes the generator counter-emf which opposes DC motor torque. See figure 1-16.

1-51. OPTIONS

1-52. Options for the Hewlett-Packard 7970A Digital Magnetic Tape Unit are fully field installable, but will usually be customer modifications stipulated, at the time of purchase, and installed at the factory. The following options are available:

- a. Write/Read data electronics.
- b. Read Only data electronics.
- c. Triple Density selection: 200, 556, and 800 bpi.
- d. Unit Address (0, 1, 2, and 3) for multi-unit operation.
- e. Seven or Nine Tracks Read Only Head Stack.
- f. Seven or Nine Tracks Write/Read Head Stack.
- g. Parity Check/Generate.
- h. ~~Cover Door~~ Interlock Switch.

ADD revised Paragraph 1-54 as follows:

1-54. The following accessories are furnished with the standard 7970A Tape Unit:

<u>PART NUMBER</u>	<u>DESCRIPTION</u>	<u>QUANTITY</u>	per Unit:
07970-00580	<u>Rack Mounting Bracket</u>	1	
2190-0034	Lockwasher, No. 10	7	
2680-0103	Screw, 10-32 x .500	3	
2680-0116	Screw, 10-32 x .375	4	
2680-0129	Screw, 10-32 x .312	4	
3050-0002	Washer, flat	7	
8120-1395	AC Power Cable	1	
07970-60420	Extender Board Assembly	1	

factory strapped for 200 or 556 bpi operation. Data written on one 7970A can be read by another 7970A or any tape recorder IBM or ASCII compatible. The 7970A will also read tape written on other tape recorders as long as they are IBM or ASCII compatible. Tape speed depends upon option selection. Tape speeds are selectable from 10 to 37-1/2 ips and are factory set.

1-44. The head assembly consists of an erase head, write head stack (7 or 9 channel), and a read head stack (7 or 9 channel). The erase head erases the full width of the tape with a flux density (known as the reset state) at least two orders of magnitude greater than the write saturation flux. Saturation recording is used so that the tape is magnetized to saturation in either of two possible directions (reset and set). The read heads sense a flux reversal as a "1" bit and no change in flux as a "0" bit.

1-45. The data handling capability of the 7970A depends upon the option features. See paragraph 1-51. Line receivers are TTL and biased positive so that the sending end must pull the line to ground to cause a "true" or logical "1" condition. "False" is a level equal to or greater than 2.0 volts. "True" is a level equal to or lower than 0.8 volts. The line normally resets at 3.5 volts. Line transmitters are DTL and biased positive to 5 volts. "False" is 1.62K to +5.0 V. "True" is a 31 mA sink at 0 to 0.4 volts.

1-46. Write option recorders are equipped with a Write Enable assembly. Before the write state can be established, write enable ring must be installed in the supply reel. The WRITE ENABLE indicator will illuminate. For read-only operation, the write enable ring is removed to prevent inadvertent recording. For write-read operations, the interface will require input/output channel capability. Units equipped with the read-only option, have seven or nine channel data lines provided with a NRZI compatible clocking pulse originating in the Read Control card. A description of the I/O lines and status/motion commands are provided in tables 2-1 and 2-2.

1-47. Built-in Service/Self-Test Feature

1-48. The Capstan Servo card is equipped with three toggle switches (REV, FWD, and +160). The +160 switch is high speed forward; the Control Panel REWIND pushbutton provides the -160 function high speed reverse. These switches are

<u>QTY</u>	<u>ITEM</u>
3	Spacers
1	Empty Reel (10-1/2")
1	Head Cleaner
1	Instruction Manual
1	Extender Board
1 pkg.	Mounting Hardware and Screws
1	Power Cord



1-55. ACCESSORIES AVAILABLE

1-56. The following accessories are available for the Model 7970A Tape Unit at extra cost:

- a. Write Test Board, HP Model 13192A.
- b. Multi-Unit Cable (12-1/2 feet), HP Part Number 13190A. er 13190A.
- c. HP Transport Test Tape, HP Part Number 5080-4525 (for 7-track application).
- d. HP Transport Test Tape, HP Part Number 5080-4526 (for 9-track application).
- e. Write Test Tape, HP Part Number 9162-0025 (Standard computer grade tape-3M777 or Memorex MRX 111 on 10-1/2 inch reels).
- f. Model 7970A Interface Guide, HP 5952-5405.
- g. Motion Control Board, HP Model 13191A (IBM).
- h. Master Alignment Tape, HP Part Number 9162-0027.
- i. Read Test Board, HP Model 13193A.

1-57. SPECIAL INSTRUMENTS

1-58. Modified versions (per customer's specifications) of any Hewlett-Packard instruments are available on special order. The manual for these special instruments (having electrical modifications) will include a separate insert sheet that

describes the modification and any special manual changes in addition to the "Manual Changes" sheet (if applicable). Contact the nearest Hewlett-Packard Field Office if either of these sheets is missing from the manual of a special instrument. Be sure to refer to the instrument by its full name and number.

1-59. EQUIPMENT IDENTIFICATION

1-60 Hewlett-Packard instruments are identified by model/option number, name.

1-60. Hewlett-Packard instruments are identified by "product line" (example: "7970A"), by "product" (example: "MOD 202"), and by description (example: "Digital Magnetic Tape Unit"). Printed circuit boards are identified by a ten-digit number and description which appears on the schematic and the parts list (example: 07970-60090, Density Select). Instruments with the same Product Line-Product numbers but different serial prefix numbers, have been updated. These changes are described in Temporary Change Pages. If this information is missing, consult the nearest Hewlett-Packard Sales and Service Office.

appendix or a revised page. If this information is missing, consult the nearest Hewlett-Packard Sales and Service Office.

1-61. SPECIFICATIONS

1-62. Refer to Table 1-2.

1-63. INSTRUMENTS COVERED BY THIS MANUAL

1-64. Each Tape Unit is provided with a MODEL (MOD) PLATE and a SERIAL NUMBER PLATE for identification. See sketch below. These two plates are attached to the Transformer Assembly Panel (interior, Rear Panel). This manual covers Tape Units with Serial Prefix 1016A and succeeding prefix numbers as updated/modified by "Temporary Change Pages". If the identifying numbers in your Tape Unit do not correspond to those in this manual, or appear on a Temporary Change Sheet accompanying the manual, consult your nearest Hewlett-Packard Sales and Service Office for assistance. A list of offices is included at the back of this manual.

manual, or appear on a (est Hewlett-Packard Sale included at the back of th

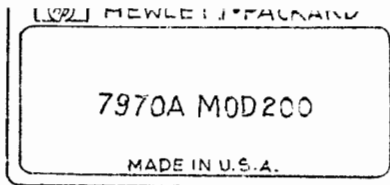

ual, consult your near- e. A list of offices is

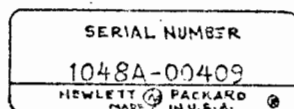

Table 1-2. Specifications

TAPE SPEED: 10 to 37-1/2 ips

REEL DIAMETER: Up to 10-1/2 inches (266,7 mm)

TAPE (Computer Grade):

Width: 0.5 inches (12,7 mm)

Thickness: 1.5 mils

TAPE TENSION: 8 oz., nominal

REWIND SPEED: 160 ips

FAST FORWARD, FAST REVERSE: 160 ips

INSTANTANEOUS SPEED VARIATION: $\pm 3\%$

LONG-TERM SPEED VARIATION: $\pm 1\%$

FAST FORWARD, FAST REVERSE, START/STOP CHARACTERISTICS:

Distance: 40 inches, nominal

Time: 0.7 second, maximum

START/STOP TIMES: 15 ms (at 25 ips)

START/STOP TAPE TRAVEL: 0.187" ± 0.020 " (4,7625 ± 0.508 mm)

REEL MOTOR BRAKING: Dynamic

MAGNETIC HEAD ASSEMBLY:

Standard: 7- or 9-track, Erase, Write, and Read

Gap Scatter (Measured Optically):

Read Stack: 150 μ in., max.

Write Stack: 150 μ in. max.

SKEW:

Static Skew: The per channel one-shot deskewing technique is utilized in the Write (forward) and Read (forward and reverse) circuitry, effectively eliminating static skew.

Dynamic Skew: Total Dynamic Skew: ± 200 μ in. (Read after Write), max.

Table 1-2. Specifications (Continued)

RECORDING MODE: NRZI (IBM compatible)

HEAD GUIDE SPACING: IBM compatible

WRITE HEAD TO READ HEAD CROSSTALK: $\leq 5\%$ (of read signal)

READ HEAD CHANNEL TO READ HEAD CHANNEL CROSSTALK: < -30 dB

BOT* AND EOT* REFLECTIVE STRIP DETECTION: Photoelectric, IBM compatible

OPERATING ENVIRONMENT:

Ambient Temp: $+32^{\circ}$ to $+131^{\circ}$ F (0° to 55° C)

Relative Humidity (%): 20 to 80% (non-condensing)

Altitude: 10,000 ft. (3048 meters)

POWER REQUIREMENTS:

115 or 230 ($\pm 10\%$) VAC

50 to 400 Hz, single phase

400 VA, max (on high line)

DIMENSIONS:

Height: 24" (609,6 mm)

Width: 19" (482,6 mm)

Depth (from mounting surface): 12" (304,8 mm)

Overall Depth: 15-3/4" (391 mm)

WEIGHT: 125 lbs, max. (56.7 Kilograms)

TRANSPORT MOUNTING:

Vertical: Standard 19" (482,6 mm) Retma rack

Horizontal: 24" (609 mm) rack; mounted at 18.312" (465,1 mm) hole centers.

*Beginning of Tape and End of Tape.

TEMPORARY CHANGE PAGE

Product

Date of Change:

3 December 1970

MODEL: 7870, 7870A, 7870B, 7870C, 7870D, 7870E, 7870F, 7870G, 7870H, 7870I, 7870J, 7870K, 7870L, 7870M, 7870N, 7870O, 7870P, 7870Q, 7870R, 7870S, 7870T, 7870U, 7870V, 7870W, 7870X, 7870Y, 7870Z, 7870AA, 7870AB, 7870AC, 7870AD, 7870AE, 7870AF, 7870AG, 7870AH, 7870AI, 7870AJ, 7870AK, 7870AL, 7870AM, 7870AN, 7870AO, 7870AP, 7870AQ, 7870AR, 7870AS, 7870AT, 7870AU, 7870AV, 7870AW, 7870AX, 7870AY, 7870AZ, 7870BA, 7870BB, 7870BC, 7870BD, 7870BE, 7870BF, 7870BG, 7870BH, 7870BI, 7870BJ, 7870BK, 7870BL, 7870BM, 7870BN, 7870BO, 7870BP, 7870BQ, 7870BR, 7870BS, 7870BT, 7870BU, 7870BV, 7870BW, 7870BX, 7870BY, 7870BZ, 7870CA, 7870CB, 7870CC, 7870CD, 7870CE, 7870CF, 7870CG, 7870CH, 7870CI, 7870CJ, 7870CK, 7870CL, 7870CM, 7870CN, 7870CO, 7870CP, 7870CQ, 7870CR, 7870CS, 7870CT, 7870CU, 7870CV, 7870CW, 7870CX, 7870CY, 7870CZ, 7870DA, 7870DB, 7870DC, 7870DD, 7870DE, 7870DF, 7870DG, 7870DH, 7870DI, 7870DJ, 7870DK, 7870DL, 7870DM, 7870DN, 7870DO, 7870DP, 7870DQ, 7870DR, 7870DS, 7870DT, 7870DU, 7870DV, 7870DW, 7870DX, 7870DY, 7870DZ, 7870EA, 7870EB, 7870EC, 7870ED, 7870EE, 7870EF, 7870EG, 7870EH, 7870EI, 7870EJ, 7870EK, 7870EL, 7870EM, 7870EN, 7870EO, 7870EP, 7870EQ, 7870ER, 7870ES, 7870ET, 7870EU, 7870EV, 7870EW, 7870EX, 7870EY, 7870EZ, 7870FA, 7870FB, 7870FC, 7870FD, 7870FE, 7870FF, 7870FG, 7870FH, 7870FI, 7870FJ, 7870FK, 7870FL, 7870FM, 7870FN, 7870FO, 7870FP, 7870FQ, 7870FR, 7870FS, 7870FT, 7870FU, 7870FV, 7870FW, 7870FX, 7870FY, 7870FZ, 7870GA, 7870GB, 7870GC, 7870GD, 7870GE, 7870GF, 7870GG, 7870GH, 7870GI, 7870GJ, 7870GK, 7870GL, 7870GM, 7870GN, 7870GO, 7870GP, 7870GQ, 7870GR, 7870GS, 7870GT, 7870GU, 7870GV, 7870GW, 7870GX, 7870GY, 7870GZ, 7870HA, 7870HB, 7870HC, 7870HD, 7870HE, 7870HF, 7870HG, 7870HH, 7870HI, 7870HJ, 7870HK, 7870HL, 7870HM, 7870HN, 7870HO, 7870HP, 7870HQ, 7870HR, 7870HS, 7870HT, 7870HU, 7870HV, 7870HW, 7870HX, 7870HY, 7870HZ, 7870IA, 7870IB, 7870IC, 7870ID, 7870IE, 7870IF, 7870IG, 7870IH, 7870II, 7870IJ, 7870IK, 7870IL, 7870IM, 7870IN, 7870IO, 7870IP, 7870IQ, 7870IR, 7870IS, 7870IT, 7870IU, 7870IV, 7870IW, 7870IX, 7870IY, 7870IZ, 7870JA, 7870JB, 7870JC, 7870JD, 7870JE, 7870JF, 7870JG, 7870JH, 7870JI, 7870JJ, 7870JK, 7870JL, 7870JM, 7870JN, 7870JO, 7870JP, 7870JQ, 7870JR, 7870JS, 7870JT, 7870JU, 7870JV, 7870JW, 7870JX, 7870JY, 7870JZ, 7870KA, 7870KB, 7870KC, 7870KD, 7870KE, 7870KF, 7870KG, 7870KH, 7870KI, 7870KJ, 7870KK, 7870KL, 7870KM, 7870KN, 7870KO, 7870KP, 7870KQ, 7870KR, 7870KS, 7870KT, 7870KU, 7870KV, 7870KW, 7870KX, 7870KY, 7870KZ, 7870LA, 7870LB, 7870LC, 7870LD, 7870LE, 7870LF, 7870LG, 7870LH, 7870LI, 7870LJ, 7870LK, 7870LL, 7870LM, 7870LN, 7870LO, 7870LP, 7870LQ, 7870LR, 7870LS, 7870LT, 7870LU, 7870LV, 7870LW, 7870LX, 7870LY, 7870LZ, 7870MA, 7870MB, 7870MC, 7870MD, 7870ME, 7870MF, 7870MG, 7870MH, 7870MI, 7870MJ, 7870MK, 7870ML, 7870MM, 7870MN, 7870MO, 7870MP, 7870MQ, 7870MR, 7870MS, 7870MT, 7870MU, 7870MV, 7870MW, 7870MX, 7870MY, 7870MZ, 7870NA, 7870NB, 7870NC, 7870ND, 7870NE, 7870NF, 7870NG, 7870NH, 7870NI, 7870NJ, 7870NK, 7870NL, 7870NM, 7870NN, 7870NO, 7870NP, 7870NQ, 7870NR, 7870NS, 7870NT, 7870NU, 7870NV, 7870NW, 7870NX, 7870NY, 7870NZ, 7870OA, 7870OB, 7870OC, 7870OD, 7870OE, 7870OF, 7870OG, 7870OH, 7870OI, 7870OJ, 7870OK, 7870OL, 7870OM, 7870ON, 7870OO, 7870OP, 7870OQ, 7870OR, 7870OS, 7870OT, 7870OU, 7870OV, 7870OW, 7870OX, 7870OY, 7870OZ, 7870PA, 7870PB, 7870PC, 7870PD, 7870PE, 7870PF, 7870PG, 7870PH, 7870PI, 7870PJ, 7870PK, 7870PL, 7870PM, 7870PN, 7870PO, 7870PP, 7870PQ, 7870PR, 7870PS, 7870PT, 7870PU, 7870PV, 7870PW, 7870PX, 7870PY, 7870PZ, 7870QA, 7870QB, 7870QC, 7870QD, 7870QE, 7870QF, 7870QG, 7870QH, 7870QI, 7870QJ, 7870QK, 7870QL, 7870QM, 7870QN, 7870QO, 7870QP, 7870QQ, 7870QR, 7870QS, 7870QT, 7870QU, 7870QV, 7870QW, 7870QX, 7870QY, 7870QZ, 7870RA, 7870RB, 7870RC, 7870RD, 7870RE, 7870RF, 7870RG, 7870RH, 7870RI, 7870RJ, 7870RK, 7870RL, 7870RM, 7870RN, 7870RO, 7870RP, 7870RQ, 7870RR, 7870RS, 7870RT, 7870RU, 7870RV, 7870RW, 7870RX, 7870RY, 7870RZ, 7870SA, 7870SB, 7870SC, 7870SD, 7870SE, 7870SF, 7870SG, 7870SH, 7870SI, 7870SJ, 7870SK, 7870SL, 7870SM, 7870SN, 7870SO, 7870SP, 7870SQ, 7870SR, 7870SS, 7870ST, 7870SU, 7870SV, 7870SW, 7870SX, 7870SY, 7870SZ, 7870TA, 7870TB, 7870TC, 7870TD, 7870TE, 7870TF, 7870TG, 7870TH, 7870TI, 7870TJ, 7870TK, 7870TL, 7870TM, 7870TN, 7870TO, 7870TP, 7870TQ, 7870TR, 7870TS, 7870TT, 7870TU, 7870TV, 7870TW, 7870TX, 7870TY, 7870TZ, 7870UA, 7870UB, 7870UC, 7870UD, 7870UE, 7870UF, 7870UG, 7870UH, 7870UI, 7870UJ, 7870UK, 7870UL, 7870UM, 7870UN, 7870UO, 7870UP, 7870UQ, 7870UR, 7870US, 7870UT, 7870UU, 7870UV, 7870UW, 7870UX, 7870UY, 7870UZ, 7870VA, 7870VB, 7870VC, 7870VD, 7870VE, 7870VF, 7870VG, 7870VH, 7870VI, 7870VJ, 7870VK, 7870VL, 7870VM, 7870VN, 7870VO, 7870VP, 7870VQ, 7870VR, 7870VS, 7870VT, 7870VU, 7870VV, 7870VW, 7870VX, 7870VY, 7870VZ, 7870WA, 7870WB, 7870WC, 7870WD, 7870WE, 7870WF, 7870WG, 7870WH, 7870WI, 7870WJ, 7870WK, 7870WL, 7870WM, 7870WN, 7870WO, 7870WP, 7870WQ, 7870WR, 7870WS, 7870WT, 7870WU, 7870WV, 7870WW, 7870WX, 7870WY, 7870WZ, 7870XA, 7870XB, 7870XC, 7870XD, 7870XE, 7870XF, 7870XG, 7870XH, 7870XI, 7870XJ, 7870XK, 7870XL, 7870XM, 7870XN, 7870XO, 7870XP, 7870XQ, 7870XR, 7870XS, 7870XT, 7870XU, 7870XV, 7870XW, 7870XX, 7870XY, 7870XZ, 7870YA, 7870YB, 7870YC, 7870YD, 7870YE, 7870YF, 7870YG, 7870YH, 7870YI, 7870YJ, 7870YK, 7870YL, 7870YM, 7870YN, 7870YO, 7870YP, 7870YQ, 7870YR, 7870YS, 7870YT, 7870YU, 7870YV, 7870YW, 7870YX, 7870YY, 7870YZ, 7870ZA, 7870ZB, 7870ZC, 7870ZD, 7870ZE, 7870ZF, 7870ZG, 7870ZH, 7870ZI, 7870ZJ, 7870ZK, 7870ZL, 7870ZM, 7870ZN, 7870ZO, 7870ZP, 7870ZQ, 7870ZR, 7870ZS, 7870ZT, 7870ZU, 7870ZV, 7870ZW, 7870ZX, 7870ZY, 7870ZZ

Literature

TYPE: Company and Service Manual
 MODEL: 7870-0000
 DATE: PRELIMINARY-July 1970

This temporary change page adds information to page 1-29 as follows:

Paragraphs 1-65 and 1-66

1-65. MULTI-UNIT CABLE (13199A)

1-66. The Multi-Unit Cable, 13199A (accessory item) is available to provide daisy-chain capability (see Figure 1-17). One to three units may be added to the base unit and connected as illustrated in Figure 1-18. A multi-unit cable is required for each unit to be daisy-chained. The cable is 12-1/2 feet long with female connectors on one end and male connectors on the other end (Motion Control, Read, and Write connector assemblies).

Place this temporary change page immediately preceding affected page



TEMPORARY CHANGE PAGE

Product

MODEL: 7970A Magnetic Tape Unit
SERIAL PREFIX ~~XXXXXXXXXX~~ 1016A

Date of Change:

3 December 1970

Literature

TITLE: Operating and Service Manual
DOCUMENT NO: 07970-90620
ISSUE/DATE: PRELIMINARY/July 1970

adds

This temporary change page ~~replaces~~ information on page 1-30 as follows:

Figure 1-17. Multi-Unit Cable (13190A)

Place this temporary change page immediately preceding affected page.

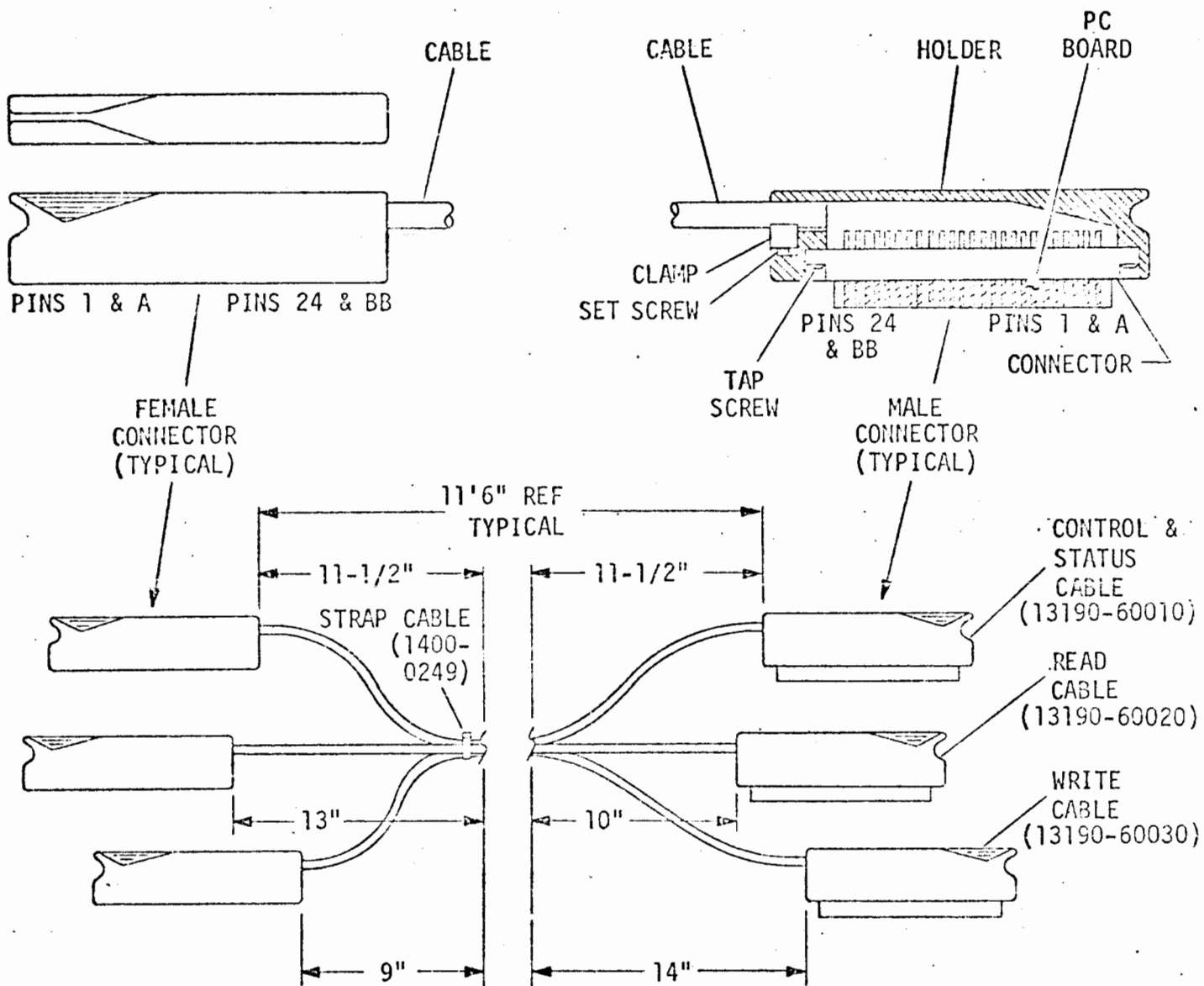

Figure 1-17. Multi-Unit Cable (13190A)

TEMPORARY CHANGE PAGE

Product

MODEL: 7970A Magnetic Tape Unit
SERIAL PREFIX ~~XXXXXXXX~~ 1016A

Date of Change:

3 December 1970

Literature

TITLE: Operating and Service Manual
DOCUMENT NO: 07970-90620
ISSUE/DATE: PRELIMINARY/July 1970

This temporary change page ~~replaces~~ adds information ~~on~~ to page 1-31 as follows:

Figure 1-18. 7970A Tape Unit Daisy-Chain Configuration

Place this temporary change page immediately preceding affected

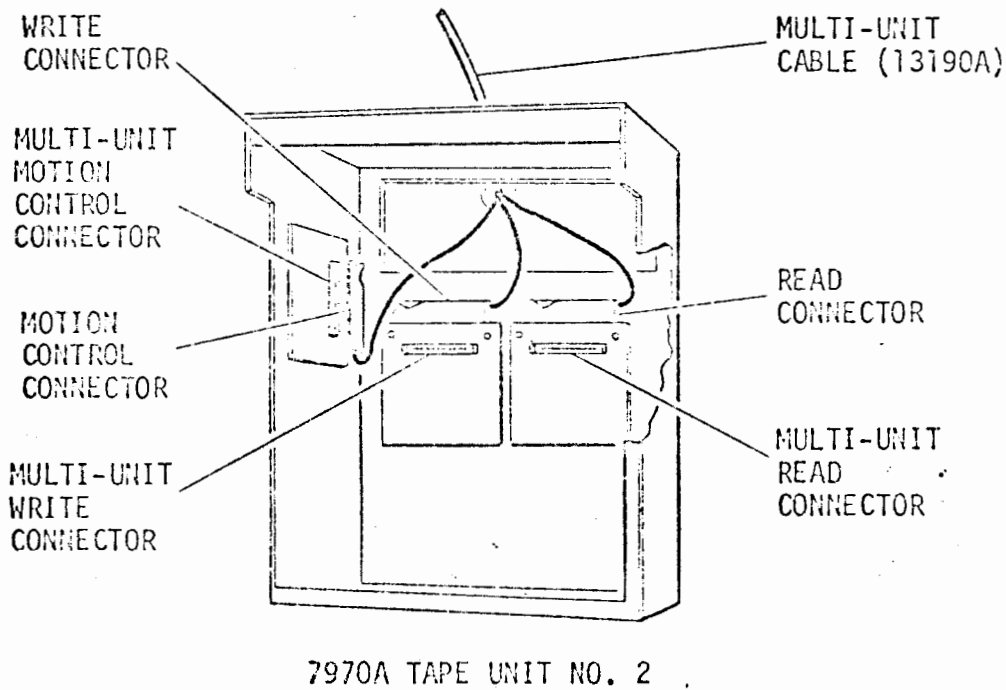
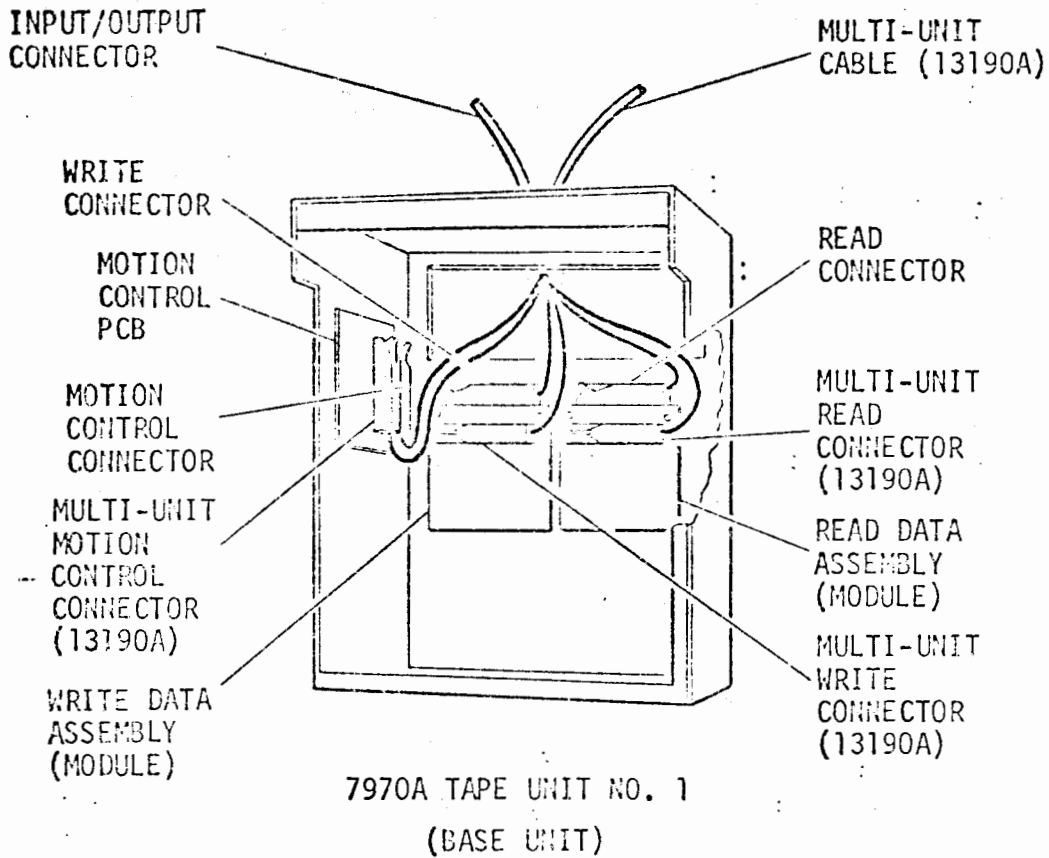

Figure 1-18. 7970A Tape Unit Daisy-Chain Configuration

SECTION II
INSTALLATION

2-1. INCOMING INSPECTION



2-2. Mechanical Check

2-3. If damage to the shipping carton is evident, request that the carrier's agent be present when the tape unit is unpacked. Visually inspect the tape unit for mechanical damage. If damage is evident, refer to paragraph 2-4 for recommended claim procedure.

2-4. Claims for Damage

2-5. If damage is evident, notify the carrier and the nearest Hewlett-Packard Sales and Service Office (refer to list of field offices at the rear of this manual). The sales and service office will arrange for repair or replacement of the unit without waiting for settlement of any claim against the carrier.

2-6. SITE SELECTION

2-7. The 7970A Digital Magnetic Tape Unit is designed for operation at sites that are not subject to excessive shocks, excessive vibration or wide ranges of ambient temperatures. The Unit should be located so as to provide access to both front and rear sections of the cabinet with sufficient room for the maximum swing radius of the Cover Door and the transport.

2-8. VENTILATION

2-9. Convection cooling is provided by perforated panels: top, bottom, and rear lower panel. No forced air ventilation is required where the exterior ambient temperature does not exceed 131° F and no other heat generating equipment is housed in the cabinet.

2-10. ALTITUDE

2-11. Operation at any altitude up to 10,000 feet is permissible.

2-12. MOUNTING INSTRUCTIONS

2-13. The 7970A can be mounted in a standard 19-inch Retma rack. The weight of the transport in open position must be considered. Ballast may be required to keep the Unit from tipping. For assistance with installation problems, the nearest Hewlett-Packard field office should be contacted.

2-14. Single-Unit - Multi-Unit Installation

2-15. The Motion Control PCB and the Write-Read Data assemblies are factory

2-15. The Motion Control PCB and the Write-Read Data assemblies are factory fitted with parallel connectors so that the Unit can be installed for single or multi-unit operation. See figure 1-6. Connector assignments are indicated in figure 2-1. A description of the input/output lines for the Motion Control PCB and the Write-Read Data assemblies are provided in tables 2-1, 2-2, and 2-3. A 12-1/2 foot multi-unit cable is available as an accessory for multi-unit operation (HP Part Number 13190A). See Tables 2-4, 2-5, and 2-6 for the Multi-Unit cable (13190A) pin connections.

unit cable is available as an accessory for multi-unit operation (HP Part Number 13190A).

2-16. INSTALLATION PERFORMANCE CHECKS

2-17. After the 7970A has been mounted, Operator's Checkout Procedures (section IV) should be performed. As indicated in Section IV, the On-Line performance checks will depend upon Unit application. Off-Line performance checks can be performed by the operator. No test equipment is required.

Add NOTE: Tape Unit equipped for 9-Channel Write-Read operation.

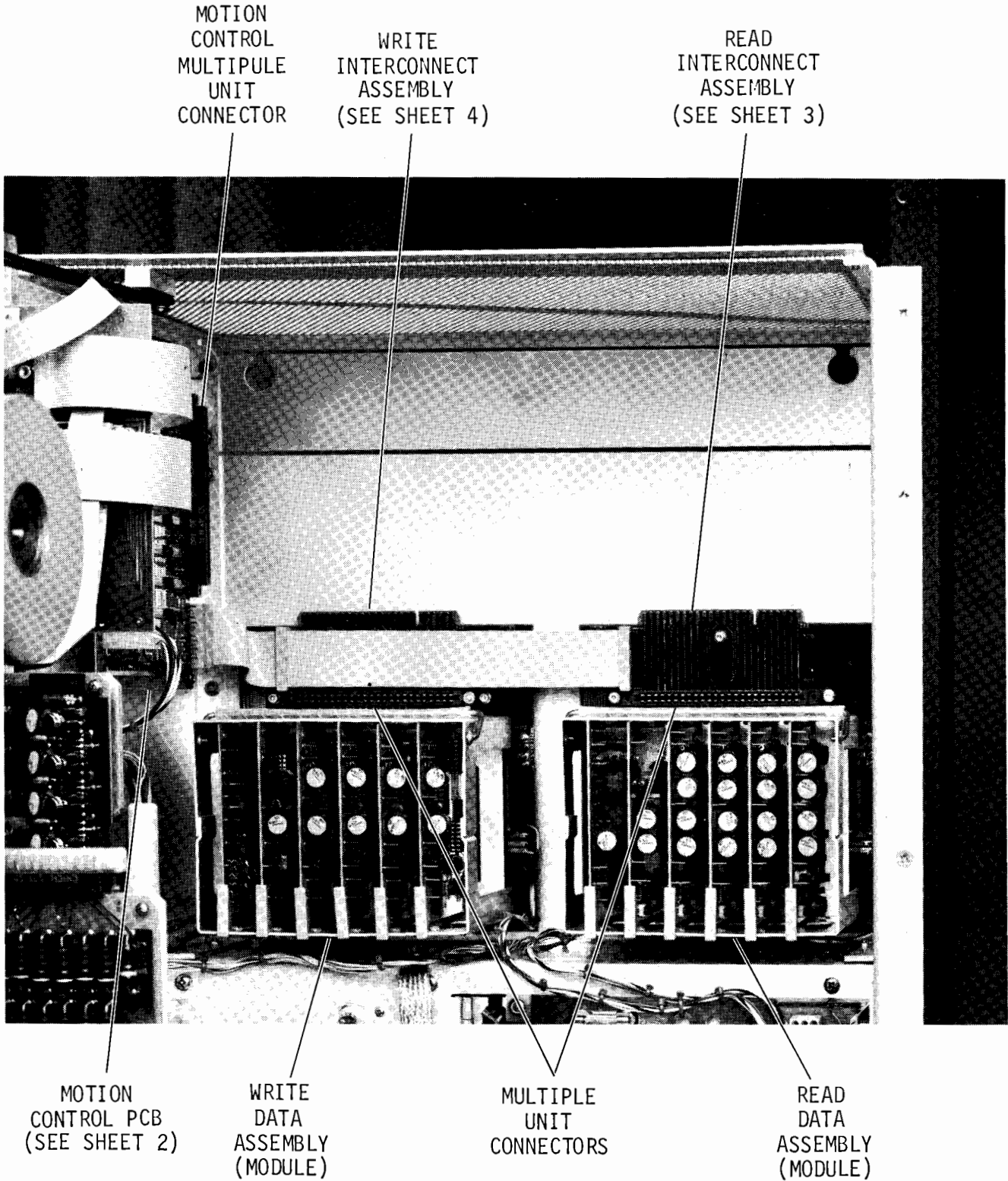

7970-A-22-1

Figure 2-1. Read Data, Write Data, and Motion Control/Status Connectors (Sheet 1 of 4)

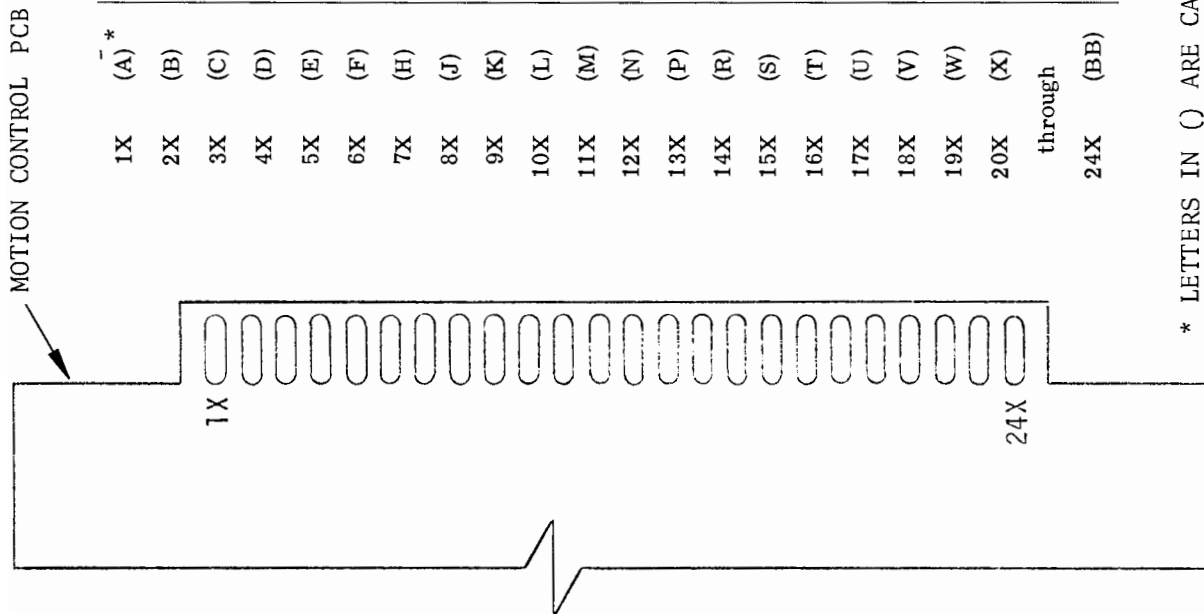

1X (A) *	1	ON-LINE STATUS	SL
2X (B)	2	LOAD POINT STATUS	SLP
3X (C)	3	REWIND STATUS	SRW
4X (D)	4	END OF TAPE STATUS	SET
5X (E)	5	READY STATUS	SR
6X (F)	6	FILE PROTECT STATUS	SFP
7X (H)	7	DENSITY 800 STATUS	SD8
8X (J)	8	DENSITY 556 STATUS	SD5
9X (K)	9	DENSITY 200 STATUS	SD2
10X (L)	10	SELECT UNIT 3	CS3
11X (M)	11	SELECT UNIT 2	CS2
12X (N)	12	SELECT UNIT 1	CS1
13X (P)	13	SELECT UNIT 0	CS0
14X (R)	14	REWIND COMMAND	CRW
15X (S)	15	OFF-LINE COMMAND	CL
16X (T)	16	FORWARD COMMAND	CF
17X (U)	17	REVERSE COMMAND	CR
18X (V)	18	HIGH SPEED COMMAND	CH
19X (W)	19	SET WRITE COMMAND	WSW
20X (X)	20	Reserved for Options and Spares	---
through	through		---
24X (BB)	24	Reserved for Options and Spares	---

* LETTERS IN () ARE CABLE CONNECTOR DESIGNATIONS.

Figure 2-1. Read Data, Write Data, and Motion Control/
Status Connectors (Sheet 2 of 4)

7970-A-22-2

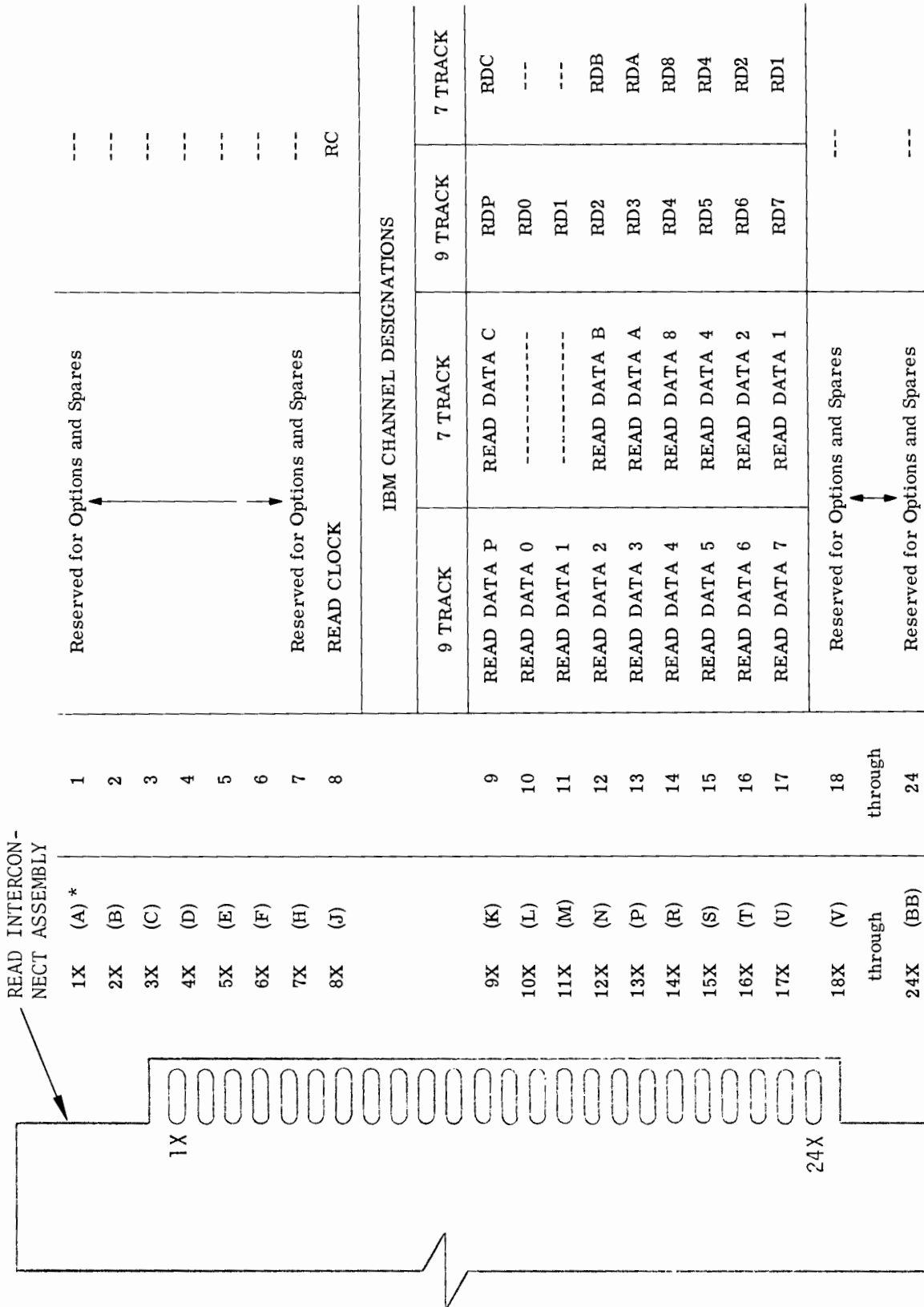

7970-A-22-3

* LETTERS IN () ARE CABLE CONNECTOR DESIGNATIONS.

Figure 2-1. Read Data, Write Data, and Motion Control/
Status Connectors (Sheet 3 of 4)

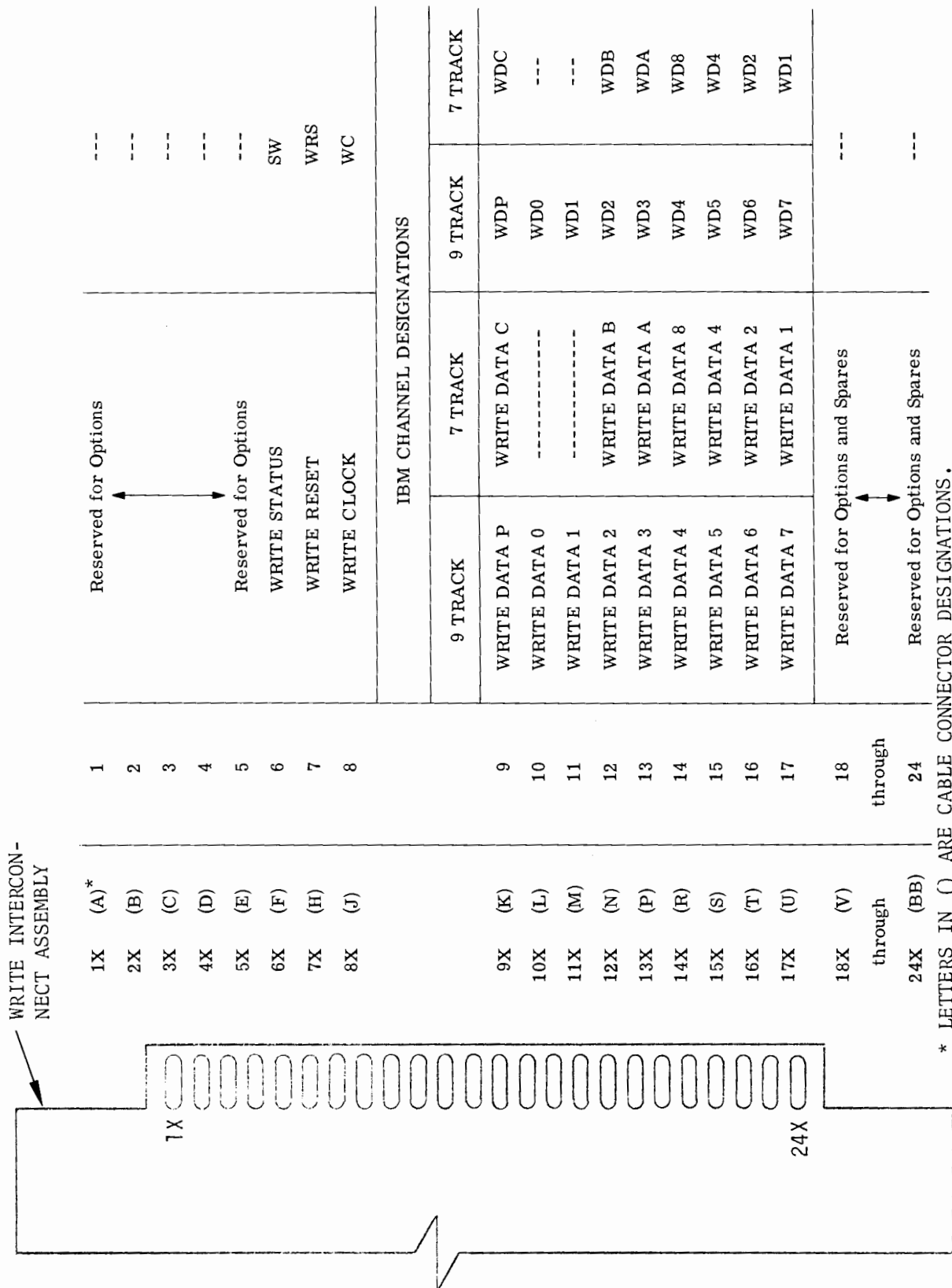

* LETTERS IN () ARE CABLE CONNECTOR DESIGNATIONS.

Figure 2-1. Read Data, Write Data, and Motion Control/
Status Connectors (Sheet 4 of 4)

Table 2-1. Motion Control/Status Connector, Description of I/O Lines

Connector	Mnemonic	Description	Signal Type	Signal Direction
1X	SL:STATUS ON-LINE	Acknowledges that the selected tape unit has been manually placed in an on-line condition	Level	Output
2X	SLP:STATUS LOAD POINT	Indicates that the tape unit is selected, is on-line, and the tape is positioned at the load point reflective strip	Level	Output
3X	SRW: RE- WIND STATUS	Indicates that the selected and on-line tape unit is engaged in a rewind operation. This status remains true until the tape is positioned at the load point reflective strip	Level	Output
4X	SET:STATUS END OF TAPE	Indicates that an end-of-tape reflective strip has passed under the photosense head of a selected and on-line tape unit. Assertion is maintained until cancellation of the end-of-tape condition by the passage of the reflective strip in the reverse direction	Level	Output
5X	SR:STATUS READY	Indicates that the tape unit is selected, is on-line, the initial loading sequence is complete, and the tape unit is complete, and the tape unit is not rewinding.	Level	Output
6X	SFP: STA- TUS FILE PROTECT	Indicates that the selected and on-line tape unit is not write enabled (write ring is not present in the file reel).	Level	Output

Table 2-1. Motion Control/Status Connector, Description of I/O Lines (Continued)

Connector	Mnemonic	Description	Signal Type	Signal Direction
7X	SD8: STATUS 800 DENSITY	Indicates that the Density Select switch has been manually set for 800 bpi	Level	Output
8X	SD5: STATUS 556 DENSITY	Indicates that the Density Select switch has been manually set for 500 bpi	Level	Output
9X	SD2: STATUS 200 DENSITY	Indicates that the Density Select switch has been manually set for 200 bpi	Level	Output
10X	CS3: COM- MAND SE- LECT UNIT 3	Selects on-line tape unit number three (group connected to a common interface cable)	Level	Input
11X	CS2: COM- MAND SE- LECT UNIT 2	Selects on-line tape unit number two (group connected to a common interface cable)	Level	Input
12X	CS1: COM- MAND SE- LECT UNIT 1	Selects on-line tape unit number one (group connected to a common interface cable)	Level	Input
13X	CS0: COM- MAND SE- LECT UNIT 0	Selects on-line tape unit number "0" (group connected to a common interface cable)	Level	Input
14X	CRW: COM- MAND RE- WIND	Clears the write command on the selected tape unit and initiates a rewind operation, provided that the tape unit is ready, and not at load point.	Level	Input

Table 2-1. Motion Control/Status Connector, Description of I/O Lines (Continued)

Connector	Mnemonic	Description	Signal Type	Signal Direction
14X (Cont)		Tape is positioned at load point at the end of this operation. Assertion should be maintained until acknowledged by rewind status. (minimum 2 μ sec.)		
15X	CL: COM- MAND OFF- LINE	Assertion of this line clears the write condition and terminates the on-line condition of the selected tape unit. Assertion should be maintained until acknowledged by the negation of the on-line status.	Level	Input
16X	CF: COM- MAND FOR- WARD	Providing the tape unit is selected and ready, this command causes tape to be driven in the forward direction.	Level	Input
17X	CR: COM- MAND RE- VERSE	When asserted, clears the write condition and causes the tape to be driven in the reverse direction, provided that the tape unit is selected, and ready. Load point status inhibits the response of this command.	Level	Input
18X	CH: COM- MAND HIGH- SPEED	When asserted with forward or reverse on a selected and ready tape unit, will cause tape speed to accelerate to 160 ips.	Level	Input

Table 2-1. Motion Control/Status Connector, Description of I/O Lines (Continued)

Connector	Mnemonic	Description	Signal Type	Signal Direction
19X	WSW: WRITE SET WRITE COMMAND	The assertion of CF causes the WSW line to be sampled following a 20 μ sec maximum delay period.	Level	Input
		Assertion transition of the WSW line enables the setting of the selected and on-line tape unit's write condition, provided the tape unit is ready and write enabled.		
		Negation of the WSW line enables the clearing of the tape unit's write condition.		
		The desired logic level of WSW shall be maintained for not less than 20 μ sec after the assertion edge of CF.		
20X thru 24X		Reserved for options and spares		

Table 2-2. Read Data Connector, Description of I/O Lines

Connector	Mnemonic	Description	Signal Type	Signal Direction
1X to 7X		Reserved for Options and Spares		
8X	RC:READ CLOCK	Indicates that a character has been read from tape and is present on the read data lines. Assertion time is 2 μ sec, minimum, 3 μ sec, maximum.	Pulse	Output
9X to 17X	RD:READ DATA (RDO- RD7 & RDP)	(Any 1 of 9 lines.) These lines transmit detected characters read from the tape and present them to the interface. The read data lines are settled at the assertion transition time of read clock, and remain settled until 1 μ sec, maximum, before the next read clock.	Level	Output
18X to 24X		Reserved for Options and Spares		

Table 2-3. Write Data Connector, Description of I/O Lines

Connector	Mnemonic	Description	Signal Type	Signal Direction
1X to 5X		Reserved for Options		
6X	SW:STATUS WRITE	Indicates that the selected tape unit is write enabled and current is flowing in the write and erase heads.	Level	Input
7X	WRS:WRITE RESET	The assertion transition causes the LRCC character to be written on tape, provided the unit is in the write mode. Assertion must be maintained for a minimum of 2 μ sec.	Level	Input
8X	WC:WRITE CLOCK	The assertion transition of this pulse causes the character, represented by the write data lines, to be written on tape. The tape unit must be in the write condition and the assertion of the write clock must be maintained for a minimum of 2 μ sec.	Pulse	Input
9X to 17X	WD:WRITE DATA (WD0-WD7 & WDP)	(Any 1 of 9 lines.) These lines receive data to be recorded on tape as a character and must be electrically stable at assertion transition time of write clock and for 2 μ sec minimum, thereafter.	Level	Input
18X to 24X		Reserved for Options and Spares		

TEMPORARY CHANGE PAGE

Product

Date of Change:

MODEL: 7970A Magnetic Tape Unit
SERIAL PREFIX ~~XXXXXXXXXX~~: 1016A

3 December 1970

Literature

TITLE: Operating and Service Manual
DOCUMENT NO: 07970-90620
ISSUE/DATE: PRELIMINARY/July 1970

This temporary change page ~~represents~~ ^{adds} information ~~on~~ ^{to} page 2-13 as follows:

Add:

Table 2-4. Control and Status Cable (13190-60010) Pin Connections

FEMALE CONNECTOR			MNEU MONIC	DESCRIPTION	MALE CONNECTOR			
WHT-BLK	A	1	WHT	SL	ON-LINE STATUS	WHT	A 1	WHT-BLK
WHT-BRN	B	2	WHT	SLP	LOAD POINT STATUS	WHT	B 2	WHT-BRN
WHT-RED	C	3	WHT	SRW	REWIND STATUS	WHT	C 3	WHT-RED
WHT-ORN	D	4	WHT	SET	END OF TAPE STATUS	WHT	D 4	WHT-ORN
WHT-YEL	E	5	WHT	SR	READY STATUS	WHT	E 5	WHT-YEL
WHT-GRN	F	6	WHT	SFP	FILE PROTECT STATUS	WHT	F 6	WHT-GRN
WHT-BLU	H	7	WHT	SD8	DENSITY 800 STATUS	WHT	H 7	WHT-BLU
WHT-VIO	J	8	WHT	SD5	DENSITY 556 STATUS	WHT	J 8	WHT-VIO
WHT-GRA	K	9	WHT	SD2	DENSITY 200 STATUS	WHT	K 9	WHT-GRA
WHT-BLK-BLK	L	10	WHT	CS3	SELECT UNIT 3	WHT	L 10	WHT-BLK-BLK
WHT-BLK-BRN	M	11	WHT	CS2	SELECT UNIT 2	WHT	M 11	WHT-BLK-BRN
WHT-BLK-RED	N	12	WHT	CS1	SELECT UNIT 1	WHT	N 12	WHT-BLK-RED
WHT-BLK-ORN	P	13	WHT	CS0	SELECT UNIT 0	WHT	P 13	WHT-BLK-ORN
WHT-BLK-YEL	R	14	WHT	CRW	REWIND COMMAND	WHT	R 14	WHT-BLK-YEL
WHT-BLK-GRN	S	15	WHT	CL	OFF-LINE COMMAND	WHT	S 15	WHT-BLK-GRN
WHT-BLK-BLU	T	16	WHT	CF	FORWARD COMMAND	WHT	T 16	WHT-BLK-BLU
WHT-BLK-VIO	U	17	WHT	CR	REVERSE COMMAND	WHT	U 17	WHT-BLK-VIO
WHT-BLK-GRA	V	18	WHT	CH	HIGH SPEED COMMAND	WHT	V 18	WHT-BLK-GRA
WHT-BRN-BRN	W	19	WHT	WSW	SET WRITE COMMAND	WHT	W 19	WHT-BRN-BRN
WHT-BRN-RED	X	20	WHT		SPARES	WHT	X 20	WHT-BRN-RED
WHT-BRN-ORN	Y	21	WHT			WHT	Y 21	WHT-BRN-ORN
WHT-BRN-YEL	Z	22	WHT			WHT	Z 22	WHT-BRN-YEL
WHT-BRN-GRN	AA	23	WHT			WHT	AA 23	WHT-BRN-GRN
WHT-BRN-BLU	AB	24	WHT			WHT	AB 24	WHT-BRN-BLU

Place this temporary change page immediately preceding affected page.

TEMPORARY CHANGE PAGE

Product

Date of Change:

MODEL: 7970A Magnetic Tape Unit
SERIAL PREFIX ~~XXXXXX~~ **1016A**

3 December 1970

Literature

TITLE: Operating and Service Manual
DOCUMENT NO: 07970-90620
ISSUE/DATE: PRELIMINARY/July 1970

This temporary change page ~~replaces~~ ^{adds} information ~~on~~ ^{to} page 2-14 as follows:

Add:

Table 2-5. Read Cable (13190-60020) Pin Connections

FEMALE CONNECTOR						MALE CONNECTOR			
WHT-GRY	(A) 1	WHT	SPARES				WHT	(A) 1	
	(B) 2		↑					(B) 2	
	(C) 3		↓					(C) 3	
	(D) 4		SPARES					(D) 4	
	(E) 5		READ CLOCK	RC		(E) 5			
	(F) 6		IBM CHANNEL DESIGNATIONS					(F) 6	
	(H) 7							(H) 7	
	(J) 8							(J) 8	
WHT-BLK-BRN	(K) 9	WHT	9 TRACK	7 TRACK	9 TRACK	7 TRACK	WHT	(K) 9	WHT-BLK-BRN
WHT-BLK-RED	(L) 10	WHT	READ DATA P	READ DATA C	RDP	RDC	WHT	(L) 10	WHT-BLK-RED
WHT-BLK-ORN	(M) 11	WHT	READ DATA 0	-----	RD0	----	WHT	(M) 11	WHT-BLK-ORN
WHT-BLK-YEL	(N) 12	WHT	READ DATA 1	-----	RD1	----	WHT	(N) 12	WHT-BLK-YEL
WHT-BLK-GRN	(P) 13	WHT	READ DATA 2	READ DATA B	RD2	RDB	WHT	(P) 13	WHT-BLK-GRN
WHT-BLK-BLU	(R) 14	WHT	READ DATA 3	READ DATA A	RD3	RDA	WHT	(R) 14	WHT-BLK-BLU
WHT-BLK-VIO	(S) 15	WHT	READ DATA 4	READ DATA 8	RD4	RD8	WHT	(S) 15	WHT-BLK-VIO
WHT-BLK-GRA	(T) 16	WHT	READ DATA 5	READ DATA 4	RD5	RD4	WHT	(T) 16	WHT-BLK-GRA
WHT-BRN-RED	(U) 17	WHT	READ DATA 6	READ DATA 2	RD6	RD2	WHT	(U) 17	WHT-BRN-RED
	(V) 18	WHT	READ DATA 7	READ DATA 1	RD7	RD1	WHT	(V) 18	
	(W) 19			SPARES				(W) 19	
	(X) 20			↑				(X) 20	
	(Y) 21			↓				(Y) 21	
	(Z) 22			SPARES				(Z) 22	
	(1) 23							(1) 23	
	(2) 24							(2) 24	

Place this temporary change page immediately preceding affected page.

TEMPORARY CHANGE PAGE

Product

Date of Change:

MODEL: 7970A Magnetic Tape Unit
SERIAL PREFIX ~~XX~~ ~~XXXXXX~~ 1016A

3 December 1970

Literature

TITLE: Operating and Service Manual
DOCUMENT NO: 07970-90620
ISSUE/DATE: PRELIMINARY/July 1970

This temporary change page ~~replaces~~ ^{adds} information ~~on~~ ^{to} page 2-15 as follows:

Add:

Table 2-6. Write Cable (13190-60030) Pin Connections

FEMALE CONNECTOR				MALE CONNECTOR								
	(A) ①			SPARES					(A) ①			
	(B) ②			↑					(B) ②			
	(C) ③			↓					(C) ③			
	(D) ④			SPARES					(D) ④			
	(E) ⑤			WRITE STATUS					(E) ⑤			
WHT-BLU	(F) ⑥	WHT		WRITE RESET				SW	(F) ⑥	WHT	WHT-BLU	
WHT-VIO	(H) ⑦	WHT		WRITE CLOCK				WRS	(H) ⑦	WHT	WHT-VIO	
WHT-GRY	(J) ⑧	WHT		WC				WC	(J) ⑧	WHT	WHT-GRA	
IBM CHANNEL DESIGNATIONS												
			9 TRACK		7 TRACK		9 TRACK		7 TRACK			
WHT-BLK-BRN	(K) ⑨	WHT	WRITE DATA P	WRITE DATA C	WDP	WDC	WHT	(K) ⑨	WHT	WHT-BLK-BRN		
WHT-BLK-RED	(L) ⑩	WHT	WRITE DATA 8	-----	WD8	----	WHT	(L) ⑩	WHT	WHT-BLK-RED		
WHT-BLK-ORN	(M) ⑪	WHT	WRITE DATA 1	-----	WD1	----	WHT	(M) ⑪	WHT	WHT-BLK-ORN		
WHT-BLK-YEL	(N) ⑫	WHT	WRITE DATA 2	WRITE DATA B	WD2	WDB	WHT	(N) ⑫	WHT	WHT-BLK-YEL		
WHT-BLK-GRN	(P) ⑬	WHT	WRITE DATA 3	WRITE DATA A	WD3	WDA	WHT	(P) ⑬	WHT	WHT-BLK-GRN		
WHT-BLK-BLU	(R) ⑭	WHT	WRITE DATA 4	WRITE DATA 8	WD4	WD8	WHT	(R) ⑭	WHT	WHT-BLK-LLU		
WHT-BLK-VIO	(S) ⑮	WHT	WRITE DATA 6	WRITE DATA 4	WD5	WD4	WHT	(S) ⑮	WHT	WHT-BLK-VIO		
WHT-BLK-GRA	(T) ⑯	WHT	WRITE DATA 6	WRITE DATA 2	WD6	WD2	WHT	(T) ⑯	WHT	WHT-BLK-GRA		
WHT-BRN-RED	(U) ⑰	WHT	WRITE DATA 7	WRITE DATA 1	WD7	WD1	WHT	(U) ⑰	WHT	WHT-BRN-RED		
	(V) ⑱			SPARES					(V) ⑱			
	(W) ⑲			↑					(W) ⑲			
	(X) ⑳			↓					(X) ⑳			
	(Y) ㉑			SPARES					(Y) ㉑			
	(AA) ㉒			↑					(AA) ㉒			
	(AB) ㉓			↓					(AB) ㉓			

Place this temporary change page immediately preceding affected page.

SECTION III
OPERATION

3-1. INTRODUCTION

3-2. The Model 7970A Digital Magnetic Tape Unit will normally function as a peripheral unit of a computerized recording system. The operator will power-up the Unit, install tape supply reel (Takeup reel is supplied installed on takeup hub.), thread tape, tension tape and move tape to loadpoint by pressing LOAD pushbutton, select recording density (option), select unit address (option), place Unit on-line, change supply reels as required, correct for a power failure, and manually rewind, or unload tape as required.

3-3. The write-read functions and the On-Line tape control functions are computer programmed. The capability to handle seven or nine tracks, read-after-write, or read-only characteristics are dependent upon unit equipped head options and associated logic.

3-4. Operator control of Off-Line functions is limited to the built-in manual controls, equipment options, and user interfaced provisions.

3-5. OPERATING CONTROLS AND INDICATORS

3-6. Controls and indicators are illustrated and defined in figure 3-1. Each control or indicator has been assigned a number which is keyed to the descriptive text.

3-7. SELECTION AND CARE OF TAPE

3-8. Tape Selection

3-9. Use computer grade tape, 0.5 inch wide and 1.5 mils thick.

3-10. Care of Magnetic Tape

3-11. Tape and reels should be handled carefully. Avoid unnecessary handling of tape to minimize tape contamination. Tape should be kept in the supplier's container when not in use; preferably stacked on end. Avoid exposure to strong magnetic fields or excessive heat (such as temporary storage in direct sunlight). When handling reels, support the reel at the hub flange to minimize reel warpage.

CONTROLS AND INDICATORS	TYPE	FUNCTION
3-ON-LINE	Momentary pushbutton with indicator.	<p>a. Switches unit to On-Line status when:</p> <p>(1) Tape has completed a BOT search or search has been stopped by a RESET command.</p> <p>(2) ON-LINE pushbutton is pressed.</p> <p>b. Lamp illuminates indicating that Unit is available to processor.</p>
4-LOAD	Momentary pushbutton switch with indicator.	<p>a. Press pushbutton and release:</p> <p>(1) Establishes tape tension.</p> <p>(2) Logic initiates loadpoint (BOT) search. Safety-switch controls: Cover Door closed or override switch pulled out.</p> <p>b. Press RESET to terminate loadpoint search. (Rewind will override Loadpoint Search.)</p> <p>c. When transport stops at loadpoint, unit will go to On-Line status if On-Line pushbutton has been pressed during LOAD operation.</p> <p>d. Places reel motors under control of the tension arm photosense circuits.</p> <p>e. Lamp illuminates, indicating that tape is at loadpoint.</p> <p>f. Write Enable indicator will also be illuminated if that option feature is installed (and supply reel is fitted with a write enable ring).</p>

Figure 3-1. Controls and Indicators (Sheet 3 of 5)

CONTROLS AND INDICATORS	TYPE	FUNCTION
5-WRITE ENABLE	Indicator	a. Available with write option package.
		b. When LOAD is pressed, indicator illuminates indicating that write enable ring is installed in supply reel.
		c. Enables power to be applied to write system.
6-DENSITY SELECT	Interlocked pushbutton switches with indicators.	a. Option feature.
		b. Allows selection of read densities: 200, 556, and 800 bpi.
		c. Indicator illuminates indicating density selected.
		d. When unit is not equipped with a Density Select option, logic will normally be set for 800 bpi.
7-ADDRESS SELECT	Interlocked pushbutton switches with indicators.	a. Option feature.
		b. When one of four switches is depressed and the indicator is illuminated, the unit is assigned an address which must be selected by the processor to control the tape unit if the Unit is in ON-Line status.
		c. When the OFF switch is depressed all four address switches are disabled and the OFF indicator is illuminated.
		d. In OFF position, Unit will not respond to any incoming signal.

Figure 3-1. Controls and Indicators (Sheet 4 of 5)

CONTROLS AND INDICATORS	TYPE	FUNCTION
8-COVER DOOR INTERLOCK SWITCH	3-Position Switch a. Cover Door closed-normal operation.	a. When Cover Door is opened, switch is functioning to hold RE-SET condition.
	b. Cover Door Open-safety interlock.	b. Safety feature: In normal position (close door and open door), prevents tape motion other than tensioning of tape until door is closed.
	c. Switch pulled out-normal operation (for maintenance purposes)	
9-POWER	On-Off toggle switch.	a. Applies AC voltage to transformer primary circuit.
		b. Switches both sides of the AC line.

Figure 3-1. Controls and Indicators (Sheet 5 of 5)

3-12. Tape Storage

3-13. Store tape at operating room temperature (60° - 80° F, 15° - 25° C, 60% humidity), with reels on edge in their original boxes, book-shelf style. If reels are stored flat, avoid stacking. Play the tape occasionally to preserve its resistance to storage conditions. If tape is stored in an environment different from the using environment, allow 12 to 24 hours for the tape to reach environmental conditions before using.

3-14. INSTALLATION/REMOVAL OF WRITE ENABLE RING

3-15. The Write Enable assembly is part of the write/read option feature. Refer to paragraph 1-19. Loaded tape reels from the tape supplier come fitted with a Write Enable Ring. For write-read operation, the write enable ring is left installed. For read only operation, the write enable ring is removed. See figure 3-2. With the write enable ring removed, no inadvertent recording on the tape is possible. This, in essence, is a file protect feature.

3-16. TAPE REEL INSTALLATION

3-17. Check supply reel before installing. Examine reel for warpage or accumulation of dust. Clean reel if dirty. Do not use damaged or warped reel. Open Cover Door and verify that transport area is clean. Pull supply hub locking lever outward. Handle supply reel by the hub flange, position on hub, press firmly and seat reel to hub. Keep even pressure on reel flange and seat Quick Disconnect lever.

3-18. TAPE THREADING PROCEDURE

3-19. To thread tape proceed as follows:

- a. Verify that tape path is clean.
- b. Install tape supply reel. Refer to paragraph 3-16.
- c. Thread tape. Refer to figure 3-3. (Verify that tape is installed between guide flanges.)
- d. Work two turns of tape on takeup reel.
- e. Place power switch to ON position.
- f. Press LOAD pushbutton.
- g. Close Cover Door.

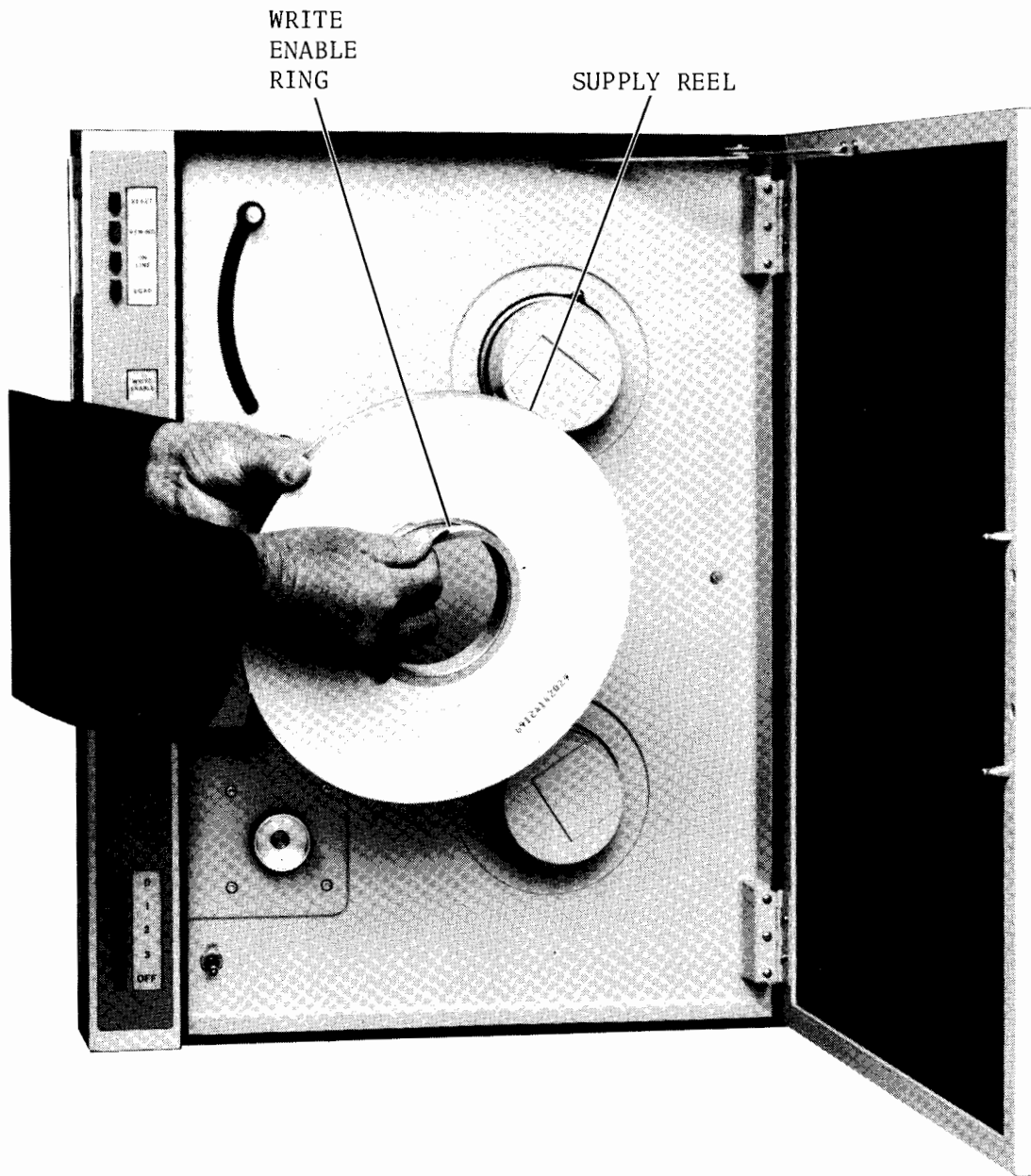

7970-A-31

Figure 3-2. Write Enable Ring Removal-Installation

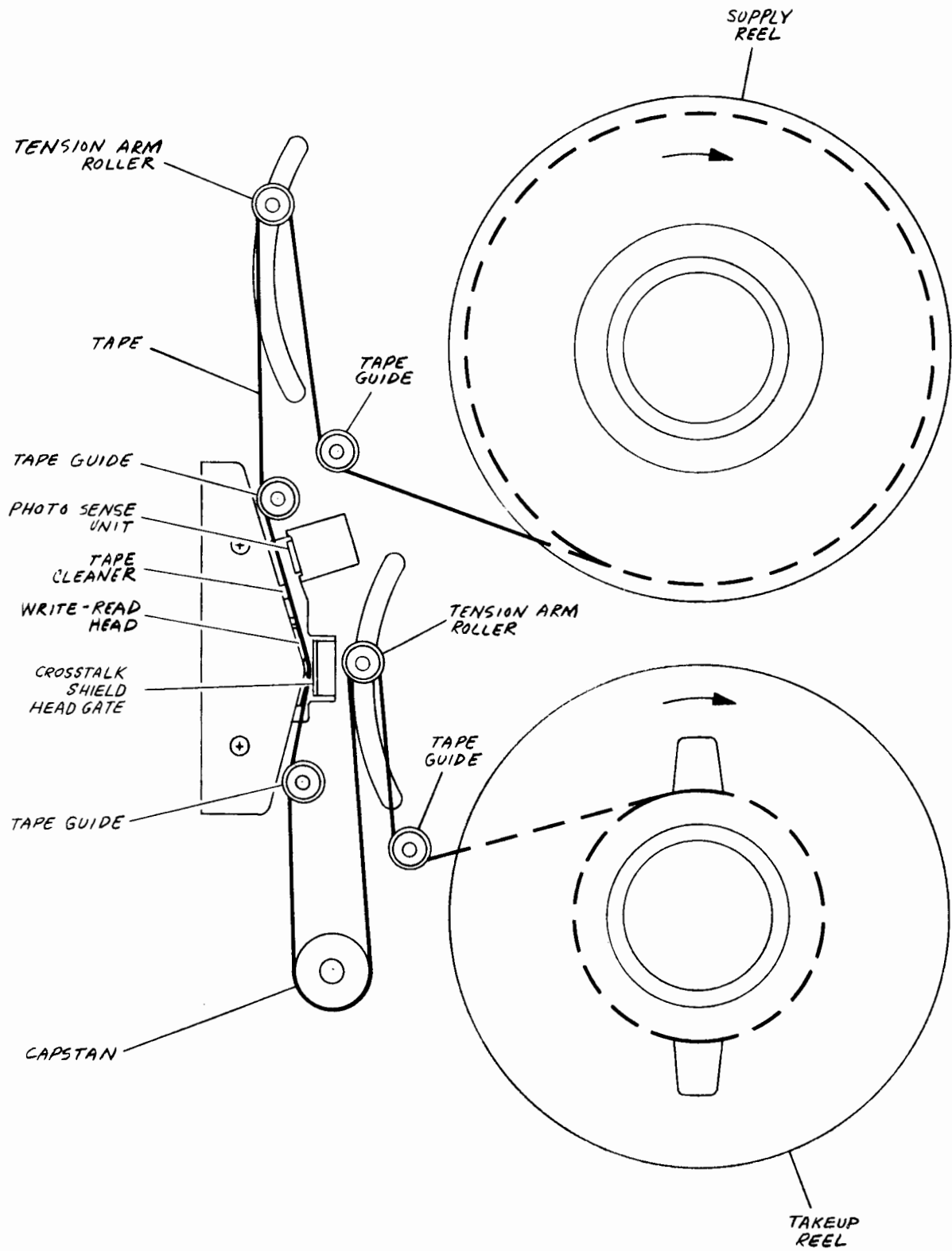

7970-A-30

Figure 3-3. Tape Threading

h. Press LOAD pushbutton and release. Motion control logic will initiate a loadpoint search (BOT tab). Tape will stop at loadpoint and LOAD pushbutton will illuminate.

3-20. ON-LINE READ ONLY OPERATION

3-21. To operate the unit in read-only mode, proceed as follows:

- a. Remove Write enable Ring from supply reel. See figure 3-2.
- b. Install supply reel. Refer to paragraph 3-16.
- c. Thread tape and place tape at loadpoint. Refer to paragraph 3-18.
- d. If unit is equipped with a Density Select option, press density selection.
- e. If unit is equipped with an Address Select option, press address pushbutton.
- f. Press ON-LINE pushbutton. Unit is now in Ready Status - under processor control.
- g. To stop unit, press RESET.
- h. Press ON-LINE to place unit under control of processor.
- i. Press Address Select OFF pushbutton to remove unit from processor control without disturbing unit logic. To place unit under processor control again, press unit Address Select pushbutton.

3-22. ON-LINE WRITE-READ OPERATION

3-23. To operate the unit in Write-Read operation, proceed as follows:

- a. Install Write Enable Ring to supply reel. See figure 3-2.
- b. The rest of this procedure is identical to the Read Only operation. Refer to paragraph 3-20 (steps b thru i).

3-24. MANUAL OPERATION

3-25. The 7970A is designed for processor controlled operation. However, manual controls are provided to bring the unit to On-Line status, to restart after a power failure, to position tape for addition of photosense tabs, and as a service aid during repair or checkout. The controls that the operator will normally use are located on the Control Panel. Three additional toggle-switch controls (REV

FWD, and +160 - high speed forward) are located on the Capstan Servo card. These controls are intended to provide service technician with additional tape control. To use the Capstan Servo switches, tape must be tensioned.

3-26. Rewind

3-27. High speed rewind can be initiated during any tape function by pressing RE-SET and then pressing REWIND. To stop rewind at any tape position, press RE-SET. To resume rewind, press REWIND. Fast rewind will continue until the loadpoint tab is sensed and passed. Unit logic will automatically go into loadpoint search and stop at loadpoint.

3-28. Restart After Power Failure

3-29. After a power failure during a read, write, or read-after-write operation, the unit will be off-line. To resume interrupted function, proceed as follows:

- a. Open Cover Door.
- b. Verify that tape is on guides.
- c. Press LOAD.
- d. Close Cover Door.
- e. Press RESET.
- f. Press ON-LINE.

3-30. REV, FWD, and +160 Capstan Servo Toggle Switches

3-31. To use the REV (Reverse), FWD (Forward), and +160 (high speed forward at 160 ips) switches proceed as follows:

- a. Open Cover Door.
- b. Install tape supply reel.
- c. Thread tape.
- d. Place power switch to ON position.
- e. Tension tape.
- f. Release transport latch. See figure 1-2.
- g. Close Cover Door and swing transport open.

- h. Operate service switches as desired.
- i. Leave all switches in OFF position before assuming normal operation.

3-32. Installation of BOT and EOT Photosense Tabs

3-33. Install EOT and BOT tabs as indicated in figure 3-4. The ten-feet (tab to end of tape) requirement is minimum. Handle tape with clean hands and avoid excessive handling in recording area. BOT tabs (beginning-of-tape; also called load-point) and EOT tabs (end-of-tape) are installed by the tape supplier. However, if the tabs come loose, or because of tape breakage, new tabs are required, they may be installed by the operator. Use IBM tabs (part number 352407, or equivalent). These tabs are made with a pressure-sensitive adhesive which is attached to the shiny side (non-oxide) of the tape. Tape transport control is required to position the tape. Refer to paragraphs 3-26 and 3-30.

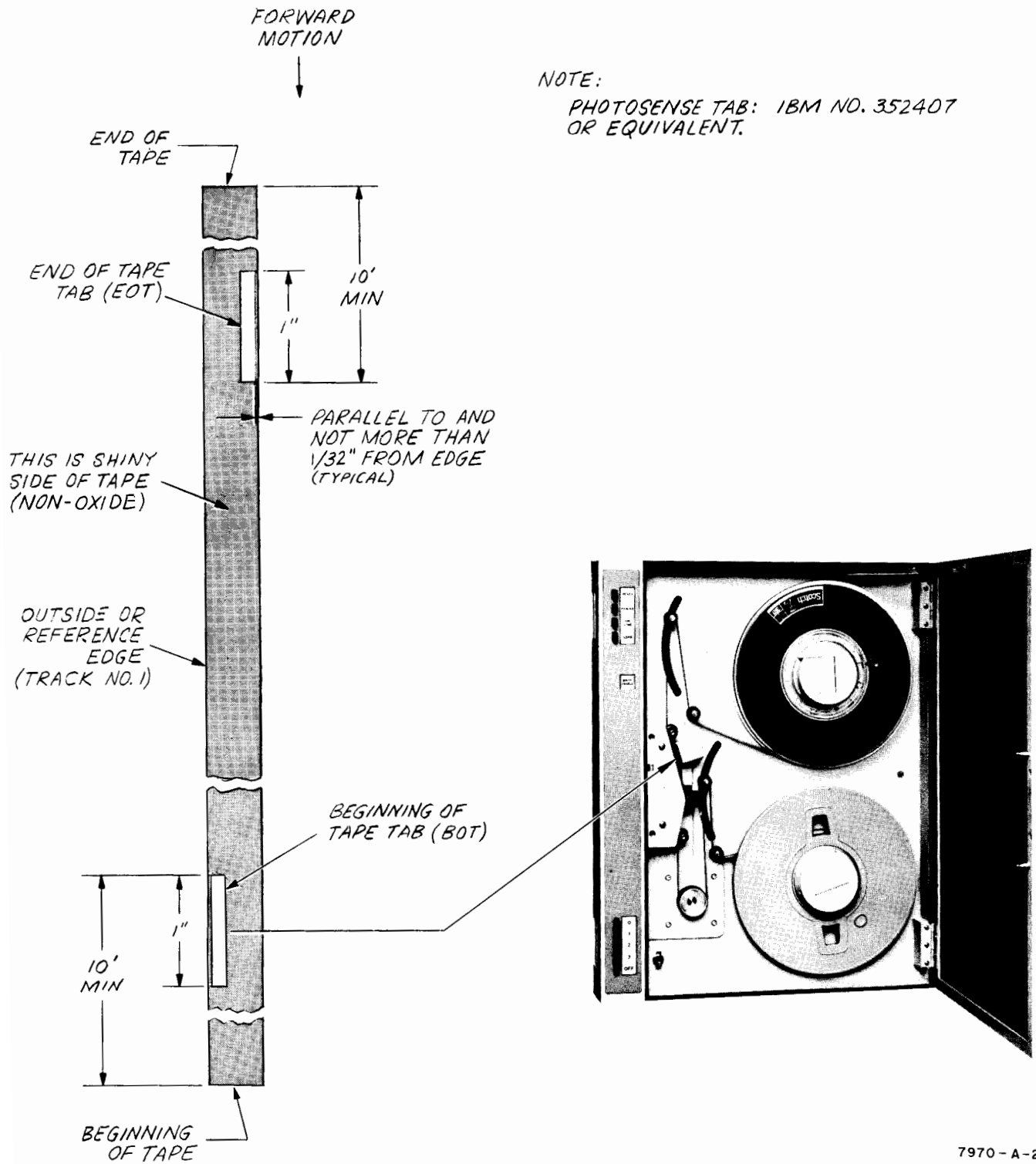

Figure 3-4. Installation of Photosense Tabs



SECTION IV

OPERATOR'S CHECKOUT PROCEDURES

4-1. INTRODUCTION

4-2. This section contains performance checks which may be used for incoming inspection or as an overall performance checkout after making adjustment or repairs. Off-Line performance checks should be performed as soon as the unit is installed to determine that it is in proper working order. No test equipment is required. Electronic checkout procedures requiring test equipment which are to be performed after making adjustments or repairs are included in section VII. Section VII also includes checkout procedures which determine that electronic motion control and data recording logic are within table 1-2 Specifications.

4-3. On-Line performance checks will depend upon unit application. On-Line refers to a unit that is physically connected to a controlling device, such as a computer, plotter, or key-to-tape system and is immediately addressable by the controller or requires a minimum amount of operator intervention such as pressing the on-line or address switches. On-Line performance procedures check the tape motion response of the unit to processor commands, tape status output signals, and input-output data electronics. Where the unit is to be used for On-Line application other than small computer peripheral application, the user should devise checks suitable to verify the special requirements.

4-4. OFF-LINE PERFORMANCE CHECKS

4-5. Mechanical Check

4-6. Perform a mechanical check as follows:

- a. Open and close Cover Door and note that detents hold firmly.
- b. Swing Cover Door open and note that hinges are free and that the door stop bracket prevents the Cover Door opening more than approximately 105° .
- c. Press upper Control Panel pushbuttons and note that the Reset, Rewind, On-Line, and Load pushbuttons depress freely and bottom.
- d. Press Density Select and Address Select pushbuttons and note that the mechanical interlocks are working properly.

- e. Release the Transport latch and swing the transport out:
 - 1. Verify that the unit is securely mounted and will not tip from the weight of the opened transport.
 - 2. Note that hinge action is smooth and that the transport is stopped at approximately 105° arc swing.
- f. Verify that all cable connectors are securely seated.
- g. Verify that all motion and data cards are securely seated.
- h. Verify that there is unobstructed airflow for instrument cooling.
- i. Slowly close/open transport and note that wire harnesses, wire cable, and ribbon cables fold properly.
- j. Close and latch transport.
- k. Open/close Cover Door and note that it rests snugly against rubber seal.

4-7. Motion Control Checkout Procedure

4-8. Perform the motion control checkout procedure as follows:

- a. Connect AC power and check 115-230 VAC Slide Switch for proper line voltage.
- b. Verify that manual control switches located on the Capstan Servo PCB are in the OFF position (switch levers down).
- c. Place power switch to ON position. The following pushbutton indicators will illuminate: Reset, Unit Address, and Density Select.
- d. Place a reel of tape on the supply hub (with BOT and EOT tabs attached). Remove Write Enable ring. Reel should be seated firmly to the hub when the quick disconnect hub is latched.
- e. Verify that empty reel on the takeup hub is properly seated.
- f. Thread tape and verify that tape is inserted between tape guide flanges.
- g. Press LOAD pushbutton and release. Tape will move until tape tension arms are centered and proper tape tension is established. Reel motors are now under control of the tension arm photosense circuits.
- h. Close Cover Door.
- i. Press LOAD pushbutton. Motion control logic initiates a loadpoint search. Tape will move forward at normal tape speed and will stop at loadpoint. LOAD indicator will illuminate.

e. Release the Transport latch and swing the transport out:

1. Verify that the unit is securely mounted and will not tip from the weight of the opened transport.

2. Note that hinge action is smooth and that the transport is stopped at
Add step 'j' to Paragraph 4-6 and re-number remaining steps as follows:

j. Verify that Select Jumper is connected to the proper pin (See Figure 1-5). The proper pin connection is as follows:

1. Tape Units equipped with Unit (Address) Select option (See Figure 3-1): Connect Select Jumper to pin labeled "OFF".
2. Tape Units not equipped with Unit (Address) Select option: Connect Select Jumper to pin labeled "0" (or any pin desired, "0" to "3").

k. Close and latch transport.

l. Open/close Cover Door and note that it rests snugly against rubber seal.

4-8. Perform the motion control checkout procedure as follows:

a. Connect AC power and check 115-230 VAC Slide Switch for proper line voltage.

b. Verify that manual control switches located on the Capstan Servo PCB are in the OFF position (switch levers down).

c. Place power switch to ON position. The following pushbutton indicators will illuminate: Reset, Unit Address, and Density Select.

d. Place a reel of tape on the supply hub (with BOT and EOT tabs attached). Remove Write Enable ring. Reel should be seated firmly to the hub when the quick disconnect hub is latched.

e. Verify that empty reel on the takeup hub is properly seated.

f. Thread tape and verify that tape is inserted between tape guide flanges.

g. Press LOAD pushbutton and release. Tape will move until tape tension arms are centered and proper tape tension is established. Reel motors are now under control of the tension arm photosense circuits.

h. Close Cover Door.

i. Press LOAD pushbutton. Motion control logic initiates a loadpoint search. Tape will move forward at normal tape speed and will stop at loadpoint. LOAD indicator will illuminate.

j. Press Density Select pushbuttons, one at a time, and note indicators. Pushbutton selected will illuminate and go dark when the next pushbutton is selected and illuminates.

k. Press Address Select pushbuttons: "0", "1", "2", "3", and OFF and note indicators. Leave one address selected. "0" pushbutton indicator will illuminate and go dark when "1" pushbutton is depressed, etc. Note that all Address Select pushbuttons are dark, except OFF, when OFF pushbutton is depressed.

1. Press ON-LINE pushbutton and release.
 1. On-Line pushbutton indicator will illuminate.
 2. The tape unit is now ready for processor control.
 3. The On-Line condition negates the REWIND and LOAD pushbutton circuits.
 4. To remove the unit from On-Line status, press RESET pushbutton.
 5. A substantial number of logic functions are initiated by the ON-LINE pushbutton. However, the following logic functions must occur before the unit is gated to On-Line status.
 - (a) The On-Line signal is and-gated with a Load Complete signal to generate a Ready Signal (RDY).
 - (b) The RDY signal is and-gated with a Select-On Line-Address (SOLA) signal to generate a Status Ready (SR) signal for the processor. (SR indicates that tape unit is selected, is On-Line, the initial loading sequence is complete, and the tape is not rewinding.)
 6. Press REWIND pushbutton; press LOAD pushbutton and observe transport response. No response should be observed.
- m. Press RESET pushbutton.
 1. ON-LINE indicator will go dark and RESET pushbutton will illuminate.
 2. Unit is now in Off-Line status. Manual controls are operative.
- n. Check REWIND and Capstan manual controls as follows:
 1. Open Cover Door and release transport latch.
 2. Close Cover Door.
 3. Swing transport open.

4. Place Capstan Servo FWD switch to ON position (up). Observe that tape moves in forward direction.
5. Place FWD switch to OFF position. Observe that tape motion stops.
6. Place Capstan Servo +160 (ips) switch to ON position.
 - (a) Observe that tape winds on to takeup reel at high speed.
 - (b) Allow approximately 100 feet of tape to wind on takeup reel.
 - (c) Place +160 switch to OFF position. Observe that tape motion stops.
7. Place Capstan Servo REV switch to ON position.
 - (a) Observe that tape moves in reverse direction.
 - (b) Place REV switch in OFF position. Observe that tape movement stops.
8. Press REWIND pushbutton (Control Panel). Observe that tape winds on to supply reel at high speed.
9. Press RESET pushbutton.
 - (a) Observe that tape movement stops.
 - (b) REWIND pushbutton will go dark.
 - (c) RESET indicator will illuminate.
10. Press REWIND pushbutton.
 - (a) Observe that transport goes into fast rewind.
 - (b) Open Cover Door.
 - (c) Observe that tape movement stops. (The interlock switch (option) has the same function as RESET).
 - (d) Close Cover Door.
 - (e) Press REWIND pushbutton.
 - (f) Observe that RESET button is dark.
 - (g) Observe that REWIND indicator is illuminated.
 - (h) Observe that tape winds past the loadpoint tab, stops, and that unit logic initiates a loadpoint search and comes to stop at loadpoint.
 - (i) Observe that LOAD indicator illuminates.

11. Hold REWIND pushbutton down until EOT tab passes photosense unit and then release pushbutton.
 - (a) Observe that tape winds off the takeup reel.
 - (b) Observe that REWIND pushbutton goes dark.
 - (c) The following pushbutton indicators will illuminate: RESET, Density Select, and Address Select.
- o. Remove supply reel and install write enable ring.
- p. Install supply reel.

Observe that WRITE ENABLE indicator is illuminated.
- q. Return unit to original configuration.

SECTION V

OPERATOR MAINTENANCE

5-1. INTRODUCTION

5-2. Operator maintenance will be confined to simple preventive maintenance procedures and fuse replacement. Periodic maintenance and mechanical/electrical checkout procedures should be performed on a scheduled operation basis. These procedures require test equipment normally available in a well-equipped test facility. If a system-level Maintenance Technician is not available, a Hewlett-Packard Field Service Engineer should be contacted.

5-3. PREVENTIVE MAINTENANCE

5-4. Preventive Maintenance, table 5-1, is time-oriented. The operator will only perform the 8-hour interval procedure as indicated. However, the operator should keep an hourly operating log so that the equipment will be checked, adjusted and serviced at the indicated intervals.

5-5. Eight-Hour Routine Cleaning and Check Procedure

5-6. Perform the 8-hour procedure as follows:

- a. Run tape and visually check for tape scraping on reel flanges, tape guide flanges, or uneven travel on the capstan. If tape reel flange scraping is observed, verify that the reel is properly seated on the hub. Notify Maintenance Technician if condition persists.
- b. Remove tape reels.
- c. Switch power switch to OFF position.
- d. Push Head Gate inward and hold to clean write-read heads.

NOTE

Clean tape path components with cotton-tipped applicators (HP 8520-0023, or equivalent) and lint-free wipers moistened with one of the following cleaners:

1. Hewlett-Packard Head Cleaner (HP 8500-0810).
2. Genesolve D (Allied Chemical).
3. Freon TF (Dupont)

Use cleaners sparingly, and avoid contaminating bearings. Be alert to any mechanical malfunction to prevent possible damage to recorded data.

- e. Clean heads and check for scratches.
- f. Release Head Gate to operating position.
- g. Clean tape scraper. Use a soft-bristle brush (or dry, compressed air) to clean serrations.
- h. Clean photosense head.
- i. Clean stationary and revolving tape guides. Verify that moving guides are revolving freely.
- j. Clean capstan.
- k. Clean transport area.

NOTE

1. Cover Door is fitted with plexiglas. Brush away any heavy residue with a soft-bristle brush, or compressed air, and clean gently with a wiper and commercial glass cleaner.
2. Weekly, remove Head Cover and clean area.

- l. Place power switch to ON position.
- m. Install tape reels.
- n. Thread tape.
- o. Tension tape and position at loadpoint.

~~p. Make density selection.~~

q. Make address selection.

r. Place unit On-Line.

5-7. FUSE REPLACEMENT

5-8. AC Line Fuses

5-9. The two AC line fuses are located on the interior, rear panel. See figure 1-13. For 115 VAC operation, a 4 ATT fuse is required (TT: super time lag). For 230 VAC operation, a 2 ATT fuse is required.

5-10. Secondary Voltage Fuses

5-11. The secondary voltage fuses are mounted to the power supply PCB. See figure 1-11. Fuse values are placarded at or near the fuse clip. Place a small screwdriver under the metal end of the fuse and pry outward to remove fuse. Use caution not to damage fuse clip.

Table 5-1. Operator Preventive Maintenance Schedule

Maintenance Interval (Hrs.)	Maintenance Routine
8	<ol style="list-style-type: none"> 1. Clean tape path components. 2. Visually inspect tape drive components.
500	<ol style="list-style-type: none"> 1. Perform 8-hour procedure. 2. Notify Maintenance Technician that 500-hour check procedure is due.
1000	<ol style="list-style-type: none"> 1. Perform 8-hour procedure. 2. Notify Maintenance Technician that 1000-hour check procedure is due.
2000	<ol style="list-style-type: none"> 1. Perform 8-hour procedure. 2. Notify Maintenance Technician that 2000-hour check procedure is due.
4000	<ol style="list-style-type: none"> 1. Perform 8-hour procedure. 2. Notify Maintenance Technician that 4000-hour check procedure is due.

SECTION VI
PRINCIPLES OF OPERATION

(To be supplied)

SECTION VII
PERFORMANCE CHECKOUT

7-1. INTRODUCTION

7-2. The purpose of this procedure is to provide checkout instructions which will verify Model 7970A conformance to published performance specifications, and certain manufacturing and service performance limits that will provide for continuing reliability margins during extended periods of use.

7-3. This test procedure has been written on the basis that the following general conditions will apply at all times unless specific instructions to the contrary are stated as part of a test routine.

7-4. Personnel conducting this test are presumed to be fully knowledgeable in the following areas:

- a. Operation of referenced commercial electronic test equipment.
- b. Generally familiar with Digital Magnetic Tape units, their characteristics, and their functional application in combination with computers or off line processing devices.
- c. Functionally familiar with the Model 7970A Tape Unit in detail to the extent covered.

7-5. Off-Line Operation Test Equipment

7-6. For the purpose of this procedure, it is presumed that the person conducting the test will be using either a computer or an Off-Line test set that is capable of meeting the following requirements. It is also presumed that any instruction in the operation of such equipment will be provided in documentation applicable to the equipment. In conjunction with the following statements, reference is made to Tables 2-1, 2-2, and 2-3.

- a. Provides all standard functional commands.
- b. Responds to all status outputs.
- c. Generates a variety of write data configurations.
- d. Is capable of reading data and detecting parity errors.

e. Transmits and Receives data through circuitry as specified in paragraph 1-45.

7-7. Test Environmental Conditions

7-8. The 7970A has successfully passed extensive environmental tests in accordance with Environmental Test Procedure A-7970-90390-1 and is subjected to periodic re-evaluation. All testing will be accomplished under the following conditions:

- a. Temperature: Nominally 25 Degrees C (Normal Laboratory Ambient)
- b. Humidity: 20% to 80%
- c. Power: 50 Hz to 400 Hz at 115 V rms (Tolerance as called for in specific tests)

7-9. Special Test Procedure Considerations

7-10. Since the 7970A tape unit is available in a wide range of speeds (from 10 ips to 37-1/2 ips); and to avoid tabulation of the many time vs distance conversions; the majority of the information contained in this procedure will be expressed in inches or microinches rather than time. A tape speed of 25 inches per second is also a tape speed of 25 Microinches per Microsecond.

7-11. When percentages of bit-to-bit distances are referenced, the following data is easily converted into appropriate time intervals.

Table 7-1. Bit-to-Bit Distances

Density in bpi	Bit-to-Bit Distance in Microinches
200	5,000
556	1,800
800	1,250

7-12. EQUIPMENT REQUIREMENTS

7-13. No special hand tools are required for normal adjustments. All hardware is posi-drive type and should be tightened with an appropriate screwdriver.

7-14. Electronic Test Equipment

7-15. The following electronic test equipment or equipment with equivalent capability is required to perform the adjustments.

a. A means of dynamically operating the tape unit at drive rates specified in the procedure. HP Model 13191A Control and Status Test Board is available as an economical service accessory and will meet the needs for all adjustments. Computer operation is also suitable.

b. A means of generating the write data patterns specified. HP Model 13192A Write Test Board is available as an accessory and will meet these requirements.

c. A means of verifying the data accuracy of the read data output. The HP Model 13193A Read Test Board Accessory will serve this need and aid in the analysis of any data errors.

d. The following Electronic Test Instruments are also required:

HP 140A Oscilloscope with HP 1421A Time Base Generator

HP 1421A Dual Trace Preamplifier (for HP 140A)

HP 5245L Counter with HP 5265A Digital Voltmeter Plug-in

7-16. Tape Requirements

7-17. The following tapes will be required to properly adjust the Model 7970A Tape Unit:

a. IBM Master Alignment Tape (All Ones, Full Width at 800 bpi) for master adjustment of read skew compensation. Available from IBM or may be obtained as HP Part Number 9162-0027.

b. HP Transport Test Tape (Various signals for accurate speed measurements. Recorded wavelengths are accurate to 0.1% throughout tape): HP Part Number 5080-4525 for seven track applications and 5080-4526 for nine track.

c. Write Test Tape (Standard computer grade tape such as 3M 777 or Memorex MRX 111 on 10-1/2 inch reels: HP Part Number 9162-0025.

7-18. PERFORMANCE CHECKOUT

7-19. Performance checkout procedures for the Model 7970 Digital Magnetic Tape Unit consist of:

a. Preliminary Power Off Checks

- b. Service Switches and Accessories Checks
- c. Tape Path Evaluation
- d. Power Supply Voltages Checks
- e. Tape Speeds and Capstan Servo Adjustments
- f. Transport Function, Motion, and Status Checks
- g. Read Data Electronics Checks
- h. Write Data Electronics Checks
- i. Data Transfer Characteristic Checks

7-20. Preliminary Power Off Checks

7-21. VISUAL INSPECTION. Visually inspect for workmanship and general visual quality in accordance with good commercial practice.

7-22. MECHANICAL ADJUSTMENTS. Verify proper adjustment of mechanical factors in accordance with the following:

a. Rotary Tape Guides: The Rotary Tape Guide must operate freely and have no end play.

b. Head Crosstalk Shield: The Head Crosstalk Shield should operate freely, and should have clearance between face of head and shield (Room to slip an IBM card thickness without binding).

c. Reel Servo Arm Limit Switches: The three limit switches associated with the reel servo arms must operate when the arm is approximately 1/8" from the rubber stop. The roller on the switch arm should be approximately on the center of the arm when the arm is fully against the stop. There should be positive travel of the Switch lever beyond the point at which it actuates the microswitch. Check can be made audibly if ambient noise level permits, or with an ohmmeter if room noise is too high.

d. Reel Servo Photosense Mask: The Reel Servo Arm Photosense Mask should clear the photosense cell by .010" minimum. This is not critical, but must not touch.

e. Write Enable Sensing: The write enable sensing finger nominal location dimensions should be as follows:

1. With solenoid deenergized, lower side of finger should be 5/32" above the outside diameter of the metal flange of the reel turntable.

2. With the solenoid deenergized the outer end of the finger should be 1/8" above the mounting face of the reel turntable.
3. With the solenoid energized (held in by hand operation) the finger should be 1/8" below the mounting face of the turntable and must not touch the outer diameter of the turntable under any condition.

f. **Reel Retaining Knob:** With the locking lever released, the reel should slip over the rubber grip ring easily, and it should be possible to easily rotate the reel. When the lever is closed, positive resistance should be felt as the rubber is compressed. In the locked position, it should not be possible to move the reel by hand. If slippage is suspected, place a piece of masking tape on the reel, and another on the hub. A mark placed in alignment on both pieces of tape should not become misaligned by more than 1/8" in 16 hours of operation. To correct tape reel slippage, release locking lever and loosen the pozidriv screw, rotate the Reel Retainer Knob clockwise and tighten screw. Repeat until tape reel mounts firmly and does not slip.

g. **Card Retainers:** With the data electronics card retainers in place over the cards it must not be possible to pull a card free of the connector.

h. Verify that the correct fuse values are installed in the unregulated power supply board and the AC line fuse receptacles. Correct values are etched on the board and located adjacent to the line fuses.

7-23. Operator Control Checks

7-24. Verify position of 115/230 volt selector switch; connect unit to appropriate power source and check the following operating modes.

7-25. **TAPE LOADING AND WRITE ENABLE.** Place a reel of tape (with Write Enable Ring) on unit and thread with the power switch on and the Safety Switch in Normal (achieved by first closing and then opening the cover door.) After threading tape, press LOAD and verify that the following takes place.

- a. Tape tension is established. RESET indicator comes on.
- b. WRITE ENABLE indicator comes on.
- c. All controls are inoperative, no sequence of commands can initiate tape movement.

7-26. Repeat 7-25 sequence with safety switch (option) in the override (out) position; and again with the door closed to verify the following takes place:

- a. Tape tension is established, RESET and WRITE ENABLE indicators come on.

b. Tape enters Loadpoint Search speed and stops at BOT Tab at which time the LOAD indicator comes on.

c. During Loadpoint Search operation, pressing RESET should stop tape motion.

d. During Loadpoint Search operation, pressing REWIND should place unit in REWIND mode and REWIND indicator should light.

e. REWIND should also be operative from BOT position (LOAD indicator ON).

7-27. ON LINE TRANSFER & RESET. Place the unit select jumper on the OFF pin (this is not the same as OFF on Unit Select Option); and load tape. Following completion of a load sequence with tape positioned at Loadpoint (LOAD indicator illuminated) press ON LINE and verify that unit will respond to external commands. Pressing ON LINE while loadpoint search is in process during the LOAD sequence will also result in ON LINE operation upon completing the search (LOAD indicator is ON). While ON LINE; the unit will not respond to local controls with the exception of RESET.

7-28. SAFETY SWITCH OPERATION (Option). The safety switch interlocks the Cover Door; with the door open and the override feature inoperative (switch in "normal" - refer to paragraph 7-25), no tape motion can be initiated other than that associated with providing tape tension. Opening the door should cause the tape unit to revert to a reset condition and all tape motion will stop. Closing the door and pressing RESET and ON LINE will reinstate the condition existing when the door was opened.

7-29. DYNAMIC BRAKING AND RECOVERY FROM POWER FAILURE. Place unit in rewind mode after tape is well into take-up reel. When full rewind speed is reached turn power switch off to simulate power failure. Tape should come to easy stop without any damage to tape.

a. Proceed with recovery to ON LINE status by following normal load sequence. Except that when tape unit goes into the loadpoint search mode; Load Point Tab must be simulated by pressing the RESET button. This can then be followed by an ON LINE command.

7-30. REWIND OPERATION. The REWIND control is operational only while the unit is in the RESET state which permits local control. The REWIND command will override the load command and will return the tape to the loadpoint position (Load indicator on with tape stopped). Rewind may be terminated prior to loadpoint by pressing RESET. Transfer to ON LINE is also possible immediately following this sequence.

7-31. Service Switches and Accessories

7-32. There are three service switches incorporated in the Capstan Servo Card. These together with the REWIND and LOAD controls provide a means of operating all five drive modes for service and/or adjustment purposes. There is no capability for cyclic drive operation.

7-33. Two Service Accessory Cards are available for use with the 7970A. With these cards it is possible to completely adjust and verify the performance of a 7970A Tape Unit under off-line conditions. Complete details covering these items are included with the cards. Basic capabilities are as follows:

a. 13191A Control and Status Test Board: This board provides normal drive modes as well as cyclic programming which is suitable for adjustment of the capstan start stop ramp. The board also includes status indicator lamps to verify all normal status functions. Installation is in the connector of the 7970A motion control board.

b. 13192A Write Test Board: This board plugs into the connector on the 7970A Write Interconnect Assembly and is capable of operating in conjunction with the 13191A Motion Control Board to verify all write capabilities and also provides signals required for completion of all write adjustments.

NOTE

These cards are not supplied with the 7970A Tape Unit.

7-34. Tape Path Evaluation

7-35. With undamaged tape threaded on the tape unit and with the unit in appropriate operating mode, evaluate the following characteristics of the tape path.

a. Capstan Height: Capstan height should be such that the tape is guided equal distance in from the outer and inner edge of the capstan. The air escape grooves provide a convenient means for judging. Adjustment is not overly critical.

b. Reel Servo Arm Position: Arms should be aligned with the centering marks on the rear of the casting. Adjustment is acceptable provided the arm is not out of location by more than the diameter of the arm.

c. Tape tracking over the rotary tape guides: Tracking over the guides should be smooth with no evidence of edge forces anywhere in the tape path. Transverse reflected light may be used to assist in judging. Light reflections across the 1/2" width of the tape should not be bent due to points of stress.

d. Photosense Position: Face of photosense head assembly should be parallel to the path of the tape and positioned 1/8" from the tape.

7-36. Power Supply Voltages

7-37. Both Regulated and Unregulated supplies should be checked for the following specifications.

7-38. **REGULATED SUPPLY VOLTAGES.** Regulated voltages will remain within tolerances over a primary voltage range of $\pm 10\%$. DC Voltages and tolerances are to be as specified below. The Peak-to-Peak ripple values are nominal and minor variances may be expected. Ripple is stated under tension only conditions.

a. The +5 Volt Supply must be $+5.000 \pm .050$ Vdc ($\pm 1\%$).

b. The + and -12 Volt Supplies must be 12.000 Vdc $\pm .360$ Vdc ($\pm 3\%$).

7-39. **UNREGULATED SUPPLY VOLTAGES.** Unregulated supply voltages are a direct function of line voltage. The following table of nominal values should be judged only at a line voltage of 115 Volts. RMS Ripple values are nominal and apply at 60 Hz.

a. ± 40 Volts DC: Nominal Value is ± 57 Volts; Ripple of 150 Mv P-P (Sawtooth)

b. $+ 20$ Volts DC: Nominal Value is 23 Volts; Ripple of 600 Mv P-P (Sawtooth)

c. $- 20$ Volts DC: Nominal Value is -23 Volts; Ripple of 300 Mv P-P (Sawtooth)

d. $+10$ Volts DC: Nominal Value is +12 Volts; Ripple of 900 Mv P-P (Sawtooth)

7-40. Tape Speeds and Capstan Servo Adjustment

7-41. The following tests serve to verify the proper adjustments as specified in paragraphs 8-21 and 8-28 of section VIII; and to verify conformance to related tape velocity specifications.

7-42. **CAPSTAN MOTOR OFFSET CURRENT.** Connect a suitable DC Voltmeter or oscilloscope across the 3 ohm 1% resistor (comprised of R21 and R22 in

parallel). The common side of the resistor is connected to Pin 2 of CJ-1. With the tape under tension but no tape motion, the voltage should not exceed the following referenced to 0 volts DC.

- a. Maximum acceptable operating limit: ± 100 Mv DC at 25° C.
- b. Adjustment recommended if greater than: ± 80 Mv DC.

7-43. LONG TERM SPEED VARIATION. Measure the tape speed accuracy over any interval greater than one second and under each of the five drive speeds. The principle of measurement requires that a tape having highly accurate bit-to-bit distances be read, and that the output of the read preamplifier be connected to a suitable counter. HP Transport Test Tape (referenced in 7-17b) provides frequencies accurately spaced to better than 0.1%. For the following tests, reference frequencies are based on using the signal that will be available from Channel 3-Preamplifier. This has a bit-to-bit spacing of .00150" and will produce a frequency of 10,000 Hz when reproduced at a tape speed of 30.000 IPS. Frequencies for other speeds are in direct ratio to the change in speed relation to 30 IPS. Example: 60 IPS would produce 20,000 Hz. Use this principle and check the following:

- a. High Speed Forward: 160 IPS; Basic Frequency is 53,333 Hz.
 1. Maximum Acceptable Operating Limit: ± 1050 Hz ($\pm 2\%$)
 2. Adjustment Recommended if greater than: ± 800 Hz ($\pm 1.5\%$)
- b. Rewind (High Speed Reverse): Checked identically to the limits applicable to High Speed Forward; only the Rewind Mode is used.
- c. Forward and Reverse Drive: Frequency depends on Tape Speed and must be calculated for speeds other than 25 IPS and 37.5 IPS which are tabulated below. Maximum acceptable operating limit is based on $\pm 1\%$ with adjustment recommended if speed error is $+0.8\%$ or greater.
 1. 25 IPS Drive Nominal Frequency is 8,333 Hz. Acceptable limits are ± 83 Hz; adjustment is required if greater than ± 65 Hz.
 2. 37.5 IPS Drive Nominal Frequency is 12,500 Hz. Acceptable limits are ± 125 Hz; adjustment is recommended if greater than ± 100 Hz.
- d. Loadpoint Search: 20 IPS; Basic Frequency is 6,667 Hz.
 1. Maximum acceptable limit is ± 1330 Hz ($\pm 20\%$)
 2. No adjustment is provided.

7-44. **START/STOP TIME AND DISTANCE DEFINITIONS.** Start and Stop times are precisely defined values based on tape speed.

a. Start-ramp Delay Time: The time (following a start command) required for the capstan tachometer voltage to reach a value that is greater (+ or -) than 0 Volts DC but less than 3% of the value reached at normal drive speed.

b. Start-ramp 100% Time: The time (following a start command) required for the analog output of any preamplifier track to first reach 100% of the peak-to-peak (or 0-to-Peak) value established while reading an all ones tape under steady state drive conditions.

c. Stop-ramp Delay Time: The time (following a stop command) required for the analog output of any preamplifier to fall to a peak-to-peak (or 0-to-Peak) value that is less than 100% but greater than 97% of the value established under steady state drive conditions while reading an all ones tape.

d. Stop-ramp 100% Time: The time (following a stop command) required for the capstan tachometer voltage to reach a level between 3% of its normal drive speed value and 0 volts DC.

e. Start Balance Time: The time difference between the Start-ramp 100% time and the specified start time for the tape speed involved. This period of time is allowed to provide a balance in tape distance as it offsets the time delay at full drive speed represented by the Stop-ramp Delay Time.

f. Start-ramp Time: This is the time required to accelerate the tape from zero ips to the drive speed. It is determined by subtracting the start delay time (Measured) from the Start-ramp 100% Time (also measured).

g. Stop-ramp Time: This is the time required to decelerate the tape to zero ips from the drive speed. It is determined by subtracting the Stop-ramp Delay Time (measured) from the Stop-ramp 100% time (also measured).

NOTE

These definitions apply for both forward and reverse directions. The capstan tachometer voltage will reverse polarity when direction is changed, however, there will be no observable difference in the preamplifier output waveforms.

7-45. Measurement of the characteristics defined in 7-44 requires that the tape unit be driven with commands that are adjustable to periods greater than the

specified start/stop times and that there be a provision to synchronize an oscilloscope sweep directly from these commands (both start and stop). The tape to be read may be any previously recorded tape, preferably at 800 BPI as this provides the best resolution where measurements from preamplifier outputs are required. Wavelength accuracy is not a factor in this test. Do Not make measurements during read-after-write operation.

7-46. **START MEASUREMENT.** Start Measurement (both forward and reverse) are made as follows:

a. Measure Start-ramp delay time: Specification is 0.5 Milliseconds ± 0.5 Milliseconds (1 Millisecond maximum).

b. Measure Start-ramp 100% Time: This is a function of tape speed. The following limits apply with the Capstan RAMP adjustment being made during the Forward Start Mode only.

1. 25 IPS Start-ramp 100% Time should be 14.5 Milliseconds ± 0.2 Msec for Forward Ramp; and ± 0.3 Milliseconds for Reverse Ramp.
2. 37.5 IPS Start-ramp 100% Time should be 9.5 Milliseconds ± 0.2 Msec for Forward Ramp and ± 0.3 Milliseconds for Reverse Ramp.

7-47. **START DISTANCE.** Start Distance is calculated as follows:

- a. Determine "Start-ramp Time" (per 7-44f.)
- b. Determine "Start Balance Time" (per 7-44e.)
- c. $1/2$ of the start-ramp time plus the start balance time (both in milliseconds) multiplied by the tape speed in inches per second equals the start distance (in inches $\times 10^{-3}$) Spec: 0.1875" ± 0.020 ".

7-48. **STOP MEASUREMENT.** Stop Measurements (both forward and reverse) are made as follows:

a. Measure Stop-ramp delay time: Specification is 0.5 Milliseconds ± 0.5 Ms. (1 Millisecond maximum).

b. Measure Stop-ramp 100% Time: Specification is a function of tape speed, and must not exceed a time that is at least 0.2 Milliseconds less than the specified stop time for the tape speed involved.

7-49. **STOP DISTANCE.** Stop Distance is calculated as follows:

- a. Determine Stop-ramp Delay time. (per 7-44c.)
- b. Determine Stop-ramp Time. (per 7-44g.)

c. The stop-ramp delay time plus $1/2$ the stop ramp time (both in milliseconds) multiplied by the tape speed in inches per second equals the stop distance (in inches $\times 10^{-3}$). Spec: $0.1875'' \pm 0.020''$.

7-50. INSTANTANEOUS SPEED VARIATION. Instantaneous speed variation is a measurement of the short term departure of the tape velocity from its long term average speed. Measurement is made as follows:

a. Write a reasonable length of "All Ones at 800 BPI" and rewind as required to be in position to reproduce this section of tape.

b. Connect scope to any convenient preamplifier output, position so that waveform is centered on screen and adjust main sweep sync for positive slope and to trigger at the zero crossover.

c. Use the delayed sweep feature to position the delayed sweep at the next zero axis crossover (this corresponds to one bit-to-bit distance) with the delayed sweep auto triggered from main (delaying) sweep.

d. Adjust delayed sweep rate to permit good resolution of the time shift band at the zero axis crossover. During this evaluation the vertical gain and the delaying sweep time may be adjusted to optimize the resolution. If the correct point is being observed it will be the waveform that is coming from top left of screen to bottom right with the slope depending on the gain and delayed sweep speed.

e. Observe the jitter band under conditions in (d) in microseconds peak-to-peak time displacement and determine this distance in microinches. This value must not exceed the following limits which are based on $\pm 3\%$ Instantaneous Speed Variation:

1. 800 BPI must not exceed ± 37.5 Microinches (75 Microinches peak-to-peak.)
2. 556 BPI must not exceed ± 54 Microinches (108 Microinches peak-to-peak.)
3. 200 BPI must not exceed ± 150 Microinches (300 Microinches peak-to-peak.)

NOTE

Above values apply to both the forward and reverse modes.

7-51. DYNAMIC TAPE SKEW. Dynamic tape skew is that variation in tape velocity which generates a differential time position with respect to the two outermost tracks on the tape. Measurement is made as follows:

a. Write a reasonable length of "All Ones tape" (or use the same tape written in 7-50a). Rewind as required to reproduce this section of tape.

b. Use dual trace scope and connect to preamp output of the two outside tracks (Channels 4 and 5). Use chopped mode (triggered by Channel A) with the main sweep synchronized for positive slope triggered at zero axis crossover. (Use negative slope in reverse direction).

c. Adjust both channel gains and positions to superimpose the two waveforms (amplitude only; there will be varying degrees of time difference due to static skew characteristics).

d. Use the delayed sweep feature to present the next (one bit-to-bit distance later) zero axis crossover on the delayed sweep. The delayed sweep must be on Internal Sync, triggered on the negative slope. (Use positive slope in reverse direction). If the waveform is correct, there will be a presentation similar to that described in 7-50d, except that there will be two traces. The earliest of the two tracks will sync the delayed sweep and the other will arrive later and will have jitter that represents the time differential in microseconds peak-to-peak. Again gains must be adjusted as high as possible (both the same) and the delayed sweep trigger set for maximum stability of the stable waveform. There will be a considerable dead zone in the delaying sweep adjustment. Use the first operating position as the sweep is moved out from minimum delay position. There is no significance to the time differential between the stable and unstable waveforms. Also, this does not represent static skew as the difference is a function of scope gain and position settings.

e. Measure the peak-to-peak time band of the unstable waveform as it crosses the zero axis. Convert this to microinches peak-to-peak for the tape speed involved. Worst Case must not exceed ± 50 Microinches (100 microinch Peak-to-Peak) and applies to forward or reverse mode.

7-52. FAST FORWARD/REVERSE START/STOP CHARACTERISTIC. Fast Forward and Fast Reverse characteristics are measured by synchronizing an oscilloscope with the appropriate drive command, and observing the DC output of the Tachometer using the TACH test point on the capstan servo card.

CAUTION

Do not issue sequential fast drive commands without allowing time to reach full speed or to return to zero speed. Failure to observe this precaution may cause excessive power dissipation in the reel servo amplifier circuitry. Minimum time between commands should be 1 second or the sum of the start and stop times measured (whichever is greater).

7-53. Fast Forward/Reverse; Start or Stop Times are measured by observing the time (following a start or stop command) required for the tachometer output to either reach its maximum value (for start time) or to fall to zero (for stop time.) Nominal times are from 400 to 700 milliseconds. Typically the value will be 600 milliseconds with no change in tape velocity occurring during the first 100 milliseconds. (500 milliseconds of ramp time).

7-54. Fast Forward/Reverse; Start or Stop Distances are determined by the time required for the ramp to move from one state to the other. This time is nominally 500 milliseconds. One-half of this time multiplied by 160 ips equals the nominal start/stop distance of 40 inches. No tolerances is applicable.

7-55. Transport Function, Motion and Status

7-56. The following checks cover the I/O lines in the Status & Motion Command Connector. Use appropriate off-line test equipment as described in paragraph 7-5, and verify proper performance as indicated.

7-57. FUNCTION COMMANDS. Select, CS: The motion control board includes a jumper that can serve to establish unit identification where the front panel select option is not present. If no select function is desired, the jumper can be placed in the Off position which will permit response to controller commands, when unit is in ON-Line with load sequence completed, and is not rewinding. Check following conditions.

- a. Unit responds to commands with jumper in OFF.
- b. Unit responds to 0 through 3 positions when corresponding CS0 through CS3 is selected by the controlling device.
- c. When Front Panel Select option is included, place internal jumper in the off position and verify that response to 0 through 3 buttons is same as (b) above.

When the Front Panel OFF button is depressed, unit must not respond to any commands from the controlling device.

7-58. Off-Line, CL: Verify that this line clears the write condition and returns the selected tape unit to the RESET condition.

7-59. MOTION COMMANDS. Verify that the following external commands will place the selected and on-line tape unit in the corresponding drive mode:

- a. Forward, CF: Tape drives forward.
- b. Reverse, CR: Tape drives reverse and stops at loadpoint tab.
- c. Rewind, CRW: Tape unit enters rewind mode, remains on-line.
- d. High Speed, CH: Tape unit will respond only when this is combined with either a forward or reverse command. When so combined, tape will drive at 160 ips speed. CH with CR will drive reverse past loadpoint.

CAUTION

Separate Sequential Commands as stipulated in paragraph 7-52.



7-60. STATUS OUTPUTS. Verify that the following status outputs are true when a selected and ready tape unit is in the condition indicated.

- a. On-Line, SL: True when selected tape unit has been manually placed on-line.
- b. Ready, SR: True when selected unit is on-line; tape loading cycle completed; and is not in rewind mode.
- c. Load Point, SLP: True when selected tape unit has tape positioned at the loadpoint reflective strip.
- d. Density, SD2, SD5, or SD8: Verify that selected tape unit will display the density selected by the tape unit density switch if this option is present. Without this option, the tape unit will be set at 800 BPI but there will be no SD8 output.
- e. Rewind, SRW: Verify that this status remains true as long as the selected unit is in the rewind mode. Must remain true until tape is repositioned at loadpoint tab.
- f. File Protect, SFP: True when selected unit is not Write Enabled.
- g. End-of-Tape, SET: True when selected unit has moved end-of-tape tab beyond photosense head. Will remain true until tab again passes photosense head in the reverse direction.

7-61. Read Data Electronics

7-62. The following checks cover the Read Data Electronics adjustments, I/O Lines, and operational performance. Appropriate off-line test facilities are required.

7-63. **READ PREAMPLIFIER GAIN.** In the Read-After-Write Mode, with data of all ones at 200 BPI; measure the peak-to-peak output voltage at the preamplifier test points.

a. All Ones at 200 BPI Read-After-Write: 6.4 Volts peak-to-peak (± 0.3 V p-p).

b. All Ones at 800 BPI (Read Only Systems) using IBM Alignment Tape. Values will vary depending on amount of erasure of the master tape. If tape is relatively new, the nominal value should be about 4.6 Volts P-P. Optimum method is to know what the specific alignment tape will do on units that have been adjusted and checked to (a).

7-64. **READ THRESHOLD LEVEL.** Use Oscilloscope and check DC Voltage level on the Threshold test point on the read control card. Values should be as indicated:

a. During Read-after-write mode: $+1.27$ VDC ± 0.060 .

b. During Read Only mode: $+0.450$ VDC ± 0.010 .

7-65. **READ HEAD STATIC SKEW.** Read head static skew is measured optically during head manufacturing and is also verified electrically on special test facilities. At this point the maximum is 150 Microinches. When installed on the tape transport certain electrical and mechanical considerations enter as factors. These may modify the static skew to a minor degree. Measurement may be used as additional information for analysis of field performance. The electronic read de-skewing effectively eliminates this factor in normal operation. Measurement is as follows:

a. Use the IBM Master alignment tape as the source of data.

b. Connect the A Channel of the oscilloscope to the P track Preamplifier output and adjust the sweep to synchronize near the zero axis crossover on the positive slope.

c. The B Channel will be connected to the various Skew Test Points on the read cards. Channels will be used in Alternate Mode.

d. With the delayed sweep operated under a sweep rate of 2 microseconds/Cm adjust the delay to display the positive going step at the start of the Channel "P" skew delay ramp exactly on the center of the scope. This will be the 0 time reference for all other measurements. Adjust B channel gain as required to obtain good resolution.

e. Without making any further adjustments to the scope time base, move the B probe to each skew delay in sequence and note its relative position to the center of scope. Signals to the left of center are early, and may be noted as "plus" with those to the right noted as "minus" as they are later than the signal from track P.

f. When all measurements have been completed for the Forward Direction; the same sequence can be repeated for the reverse. It will be necessary to re-adjust the time delay for positioning track P to center.

g. Review data taken and determine the two tracks that are the earliest (largest plus number) and latest (largest minus number). The time differential between them (sum of two times) converted to microinches for the tape speed involved is the read head static skew. In general this number will not exceed 200 to 225 Microinches.

NOTE

For readings between 200 and 225 microinches, it may be wise to correct for the electronic time delay variation in the peak detection circuitry. This may be measured by repeating the exact steps (a) through (f) except that the A Scope probe must be connected to the Preamplifier output corresponding to the skew test point on the B Scope probe. These figures must be subtracted from the normal readings (taken with Ch P as the only sync) to determine the true head skew. Under these conditions, a true head skew in excess of 200 microinches is higher than normal but will not cause any practical problems.

7-66. COMPENSATED STATIC READ SKEW. Compensated static read skew is a measure of the degree to which the electronic time delays are effective in eliminating the read head static skew. The termination of each tracks skew delay is the fall (or negative going trailing edge) of the positive going ramp visible at the SKEW testpoints on each read card. With perfect compensation these will all coincide.

As a matter of practical consideration this seldom happens except during the period of adjustment with a specific master alignment tape. When comparisons are made during alignment tapes other than the one used for adjustment, or where the same tape is subject to possible damage, it is not uncommon to see a time difference of several microseconds depending on tape speed. Considering only a $\pm 1\%$ error in the alignment tapes, and complete stability of the skew delay there could be a difference of 25 microinches between two tapes (allowing a time difference from 2.5 microseconds at 10 IPS to 0.5 microseconds at 50 IPS). Evaluate compensated skew using the following procedure.

a. Use Channel A of the scope for the master reference for all skew measurements. Connect probe to the Skew Test Point for track "P" read card.

b. Sync the main sweep to the negative slope of Channel A waveform; and set sweep speed to display two bit-to-bit distances. This will result in a negative going trailing edge at the center of the scope and another at the right side. If there is time asymmetry in the master tape (some have this and some do not) there will be double trailing edge in the center of the screen with the time difference corresponding to the recorded pulse asymmetry on the tape. If this is visible be sure to see note following this section. Use the variable setting of the main sweep to position pulses as stated. This will assure the visibility of write time asymmetry on the master tape.

c. The delayed sweep will be used to position the next sequential bit in the center of the screen. Use the internal sync, positive slope position on the delayed sweep, and adjust the trigger level for a stable waveform. The delayed sweep should be adjusted (from the CCW position) only as far as required to permit the delayed sweep to internally trigger on the next pulse.

d. Establish final positioning of the P track reference (negative going trailing edge) point at the exact center of the screen by use of the sweep positioning controls. Be sure that the delayed sweep remains correctly calibrated as correct time differences in microseconds will be required. Some positioning can also be done with the trigger level.

e. With steps (a) thru (d) correct, use the B channel of the scope, and the chopped mode, to observe the relative position of all other tracks. Note these positions and determine the earliest and latest tracks as outlined in 7-65 d thru f.

f. If the maximum difference is 30 microinches or less there should be no further concern. If readings are between 30 and 50 microinches and (adjustment is desired) be sure to check the Write/Read skew for the unit. If this skew results in the difference being less than 25 microinches no adjustment should be made

unless there is agreement between two master skew tapes showing that the same relative error exists between the same tracks. If this occurs, it can be presumed that the unit adjustments have remained stable (Write/Read Skew within $\pm 1\%$ since last adjustment) but the previous read skew adjustment was made with a bad Alignment Tape.

NOTE

Skew measurements can become somewhat difficult if significant write time asymmetry exists. This asymmetry will be observed on some master alignment tapes as well as tapes generated by the 7970 Tape units. (Tests for this are included in the sections on Write Data Electronics.) No special steps can be taken when reading the master alignment tape, but when writing tapes for check of Write/Read skew it is important to be sure that all write pulses start with the same relative flux polarities on tape. This can be assured if there is a sequence of Reverse/Stop/Forward drive commands prior to a skew measurement. The forward command assures complete write reset conditions as the WSW line is made true.

g. Measurement of Compensated Static Read Skew in the Reverse direction may be made by the same technique (steps a thru e). Evaluation of this area becomes somewhat complex, as the magnetic characteristics of the pulse wavefronts in the reverse direction will not necessarily be symmetrical with the forward direction wavefront. This is true for alignment tapes as well as for tapes written on the 7970A.

7-67. READ CHARACTER GATE, STROBE, AND READ CLOCK. The read character gate is initiated by the first one bit to complete a read skew delay period. The fall of read skew delay provides a trigger at the NOR line causing it to move in a negative direction. This fall triggers the read character gate period which is nominally 40% of the bit-to-bit period for each density. Termination of the gate will cause the NOR line to move in a positive direction which does two things. It sets the data levels at the read outputs and initiates the leading edge of the read strobe pulse. The read strobe trailing edge then generates the read clock output.

The strobe delay time provides an interval for the read data outputs to settle before the read clock output occurs. Measure these characteristics as follows:

a. Generate an appropriate data pattern as called for, starting with an all ones program under read-after-write conditions.

b. Sync the scope on the NOR test point with the negative slope. Then adjust the main sweep rate so that the next negative going edge occurs 10 division later (each division now is 10% of the bit-to-bit period).

c. Observe that the positive going edge (end of gate) occurs between 35% and 45% of the bit-to-bit period. If the Density Select option is included check for all three densities using appropriate clock rates.

7-68. Strobe pulse delay and read clock relationships to data are measured as follows:

a. Generate a data pattern that will move a single bit through all data channels in sequence. This will provide a data output pattern and will exercise each read channel in terms of initiating a read strobe.

b. Connect the scope A Channel to the data output of any read channel using negative sync and Auto triggering mode.

c. Remove the Read Data Connector to establish standard measurement conditions. (Various lengths of cables and associated capacity will effect measurement.)

d. Set sweep speed to 0.2 Microseconds/Div and establish a stable pattern for the leading edge of data (for both negative and positive sync).

e. Using the Alternate triggered by A mode, connect the scope channel B to the read clock test point on the read control card.

f. Observe the time difference between the leading edge of data and the leading edge of clock. The clock delay must be at least 0.5 microsecond, and not more than 1.5 microseconds.

g. Observe the pulse width of the read clock. This should be between 2 and 3 microseconds.

h. Read clock output should be continuous. (Verifies that Read Strobe is being initiated by each read channel.)

7-69. Write Data Electronics

7-70. The following checks cover the Write Data Electronics Adjustments, I/O Lines, and operational performance. Appropriate off-line test facilities are required.

7-71. STATUS AND FUNCTION COMMANDS. Set Write, WSW: With Set Write function true (from controlling device) a CF command will cause the WSW line to be sampled within less than 20 μ sec following CF. If WSW is true, then the internal write condition will be set true if the tape unit is selected and on line. Measurement is made as follows:

- a. Connect the A Probe of the scope to the Write Permit test point on the Write Control Card. When this level goes in the positive direction, write permit is true, and head current is flowing.
- b. Connect the external sweep input to the forward drive command from the controlling device (CF); and arrange the controlling device to provide bi-directional commands of sufficient length to exceed the start/stop time requirements for the unit. Synchronize sweep with this command (CF).
- c. The scope display should show the write permit line going in the positive direction within 5 to 15 microseconds following CF.
- d. Observe that the following conditions exist at the Write Permit Line as tape unit is put in following modes.
 1. Sequential CF Commands: Permit remains true (steady level).
 2. Sequential CR Commands: Permit remains false (steady level).
 3. WSW Command removed and applied during Bi-directional: WSW False, write permit remains false, at steady level: WSW True, Write permit pulses with CF Command.

7-72. Write Status, SW: Check to be sure status is true when selected tape unit is write enabled and WSW is true.

7-73. WRITE TIME ASYMMETRY. Write time asymmetry is the departure (in microinches) of the effective magnetic location of a data bit from that location which would make all sequential data bits equal distance apart. Measurement is made as follows.

- a. Place unit in the read after write mode, All Ones at 800 BPI.
- b. Use A Channel of scope and connect to Read Skew Test point.
- c. Sync sweep on negative edge, and adjust main sweep rate so that the 10 divisions are equal to two bit-to-bit distances. When this is correct, there will be a negative going trailing edge at the beginning of the sweep and at the end of the sweep. At the center, there may or may not be double trailing edges (this is the time asymmetry). Scope is now calibrated at 250 microinches per horizontal division, or 25 microinches if the x 10 magnifier is used.

reel of tape. Errors that can be positively associated with defects in the tape need not negate a test. Such errors will be read in both forward and reverse drive over the same area of the tape.

7-85. **READ ONLY DATA TRANSFER.** The tape generated during read-after-write test must also be read error free in both the forward and reverse directions under read only operation.

SECTION VIII
ADJUSTMENT, ALIGNMENT, AND CALIBRATION

8-1. ADJUSTMENT PROCEDURES

8-2. This section provides procedures for electrical and mechanical adjustments. To avoid interaction and minimize overall time requirements, it is important to make adjustments in this order:

- a. Basic Transport Mechanical Adjustments
- b. Power Supply Adjustment & Checks
- c. Capstan Servo Electrical Adjustment
- d. Read Data Electronics Adjustments
- e. Write Electronics Adjustments
- f. Parity Adjustments



8-3. Equipment Requirements

8-4. Special hand tools are not required for normal adjustments. All hardware is Pozidrive type and should be tightened with appropriate screwdriver.

8-5. ELECTRONIC TEST EQUIPMENT. The following electronic test equipment, or equipment with equivalent capacity is required to perform the adjustments.

a. A means of dynamically operating the tape unit at drive rates specified in the procedure. HP Model 13191A Control and Status Board is available as an economical service accessory and will meet the needs for all adjustments. Computer operation is also suitable.

b. A means of generating specified write data patterns as called for in the procedure. HP Model 13192A Write Test Board is available as a service accessory to meet these needs. If the Write Test Board is not available, the computer programmed to give write data patterns is suitable to perform these procedures.

c. One each of the following Instruments:

- HP 140A Model Oscilloscope
- HP 1421A Model Time Base & Delay Generator (for HP 140A)
- HP 1402A Model Dual Trace Amplifier (for HP 140A)
- HP 5245L Model Counter/Digital Voltmeter
- HP 5265A Model Digital Voltmeter Plug-In (for 5245L)

cho

DVM

8-6. **TAPE REQUIREMENTS.** The following tapes will be required to properly adjust the Model 7970A Tape Unit:

a. IBM Master Alignment Tape (All Ones, Full Width at 800 BPI) for master adjustment of read skew compensation. Available from IBM or may be obtained as HP Part Number 9162-0027.

b. HP Transport Test Tape (Various signals for accurate speed measurements. Recorded wavelengths are accurate to 0.1% throughout tape): HP Part Number 5080-4525 for seven track applications and 5080-4526 for nine track.

c. Write Test Tape (Standard computer grade tape such as 3M 777 or Memorex 111 on 10-1/2 inch reels): HP Part Number 9162-0025.

8-7. Transport Mechanical Adjustments

8-8. Transport mechanical adjustments consists of tape roller guide, reel servo, write enable, and photosense head.

8-9. **TAPE ROLLER-GUIDE PRELOAD.** All roller-guides are precision referenced to the step in the shaft on which they are mounted. Under no circumstances should any adjusting shims be placed between the inner guide bearing and this step. Shimming is done at the outer end of the guide. Assembly should consist of one shim next to the bearing, then the preload washer followed by shims to remove all end play. Proper preload will exist when there is one shim beyond the number required to just remove the end play. Shim thickness is .005" nominal.

8-10. **REEL SERVO ARM PHOTONSENSE.** This adjustment is critical. Adjust as required to assure that the Reel Arm Photosense Mask does not touch the photosense lamp and cell assembly. There should be a nominal clearance of .010 inch minimum between the cell and the outer side of the mask. See Paragraph 8-15.

not critical. Adjust not touch the photo-rance of .010 to

8-11. **REEL SERVO ARM LIMIT SWITCHES.** The limit switch mounting bracket pivots on the screw that mounts the Reel Servo Arm rubber stop. The hole for the adjacent screw is elongated to provide Limit Switch positioning adjustment; this screw locks the mounting bracket in position after completion of adjustment. Mounting holes for the microswitch are also elongated, providing slight additional Limit Switch adjustment movement. To position the Limit Switch, rotate the bracket and/or adjust height position to achieve the following conditions:

a. When arm is fully against bumper, the roller on the microswitch should be approximately at the high point of the arm diameter without being over center.

b. When the arm is within 1/8 inch of the bumper stop, the microswitch must operate. Also there must be further positive movement of the switch arm between the point at which the switch closes and the servo arm in full stopped condition against the rubber bumper.

mounting bracket locked in position to provide the bracket to. Rotate the conditions.

roller should be centered.

microswitch switch arm

8-6. TAPE REQUIREMENTS. The following tapes will be required to properly adjust the Model 7970A Tape Unit:

a. IBM Master Alignment Tape (All Ones, Full Width at 800 BPI) for master adjustment of read skew compensation. Available from IBM or may be obtained as HP Part Number 9162-0027.

b. HP Transport Test Tape (Various signals for accurate speed measurements. Recorded wavelengths are accurate to 0.1% throughout tape): HP Part Number 5080-4525 for seven track applications and 5080-4526 for nine track.

d. HP Reference Amplitude Test Tape (HP5080-4547). This test tape is written all "ones" at 200 bpi, full tape width, and has a certified signal amplitude marked on each reel.

8-7. Transport Mechanical Adjustments

8-8. Transport mechanical adjustments consists of tape roller guide, reel servo, write enable, and photosense head.

8-9. TAPE ROLLER-GUIDE PRELOAD. All roller-guides are precision referenced to the step in the shaft on which they are mounted. Under no circumstances should any adjusting shims be placed between the inner guide bearing and this step. Shimming is done at the outer end of the guide. Assembly should consist of one shim next to the bearing, then the preload washer followed by shims to remove all end play. Proper preload will exist when there is one shim beyond the number required to just remove the end play. Shim thickness is .005" nominal.

8-10. REEL SERVO ARM PHOTONSENSE. This adjustment is critical. Adjust as required to assure that the Reel Arm Photosense Mask does not touch the photosense lamp and cell assembly. There should be a nominal clearance of .010 inch minimum between the cell and the outer side of the mask. See Paragraph 8-15.

8-11. REEL SERVO ARM LIMIT SWITCHES. The limit switch mounting bracket pivots on the screw that mounts the Reel Servo Arm rubber stop. The hole for the adjacent screw is elongated to provide Limit Switch positioning adjustment; this screw locks the mounting bracket in position after completion of adjustment. Mounting holes for the microswitch are also elongated, providing slight additional Limit Switch adjustment movement. To position the Limit Switch, rotate the bracket and/or adjust height position to achieve the following conditions:

- a. When arm is fully against bumper, the roller on the microswitch should be approximately at the high point of the arm diameter without being over center.
- b. When the arm is within 1/8 inch of the bumper stop, the microswitch must operate. Also there must be further positive movement of the switch arm between the point at which the switch closes and the servo arm in full stopped condition against the rubber bumper.

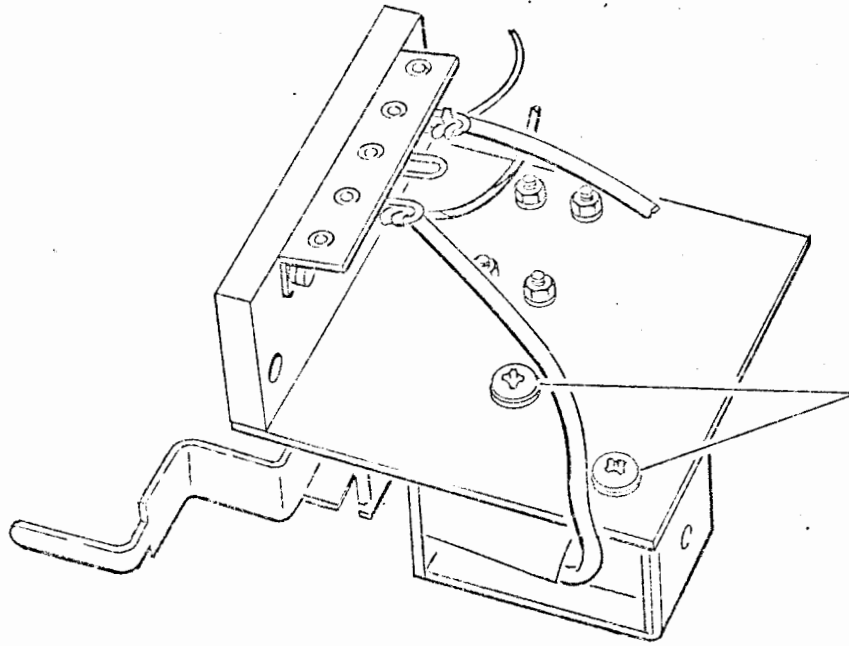

SOLENOID
MOUNTING
SCREWS (2)

SOLENOID IN
DE-ENERGIZED
POSITION

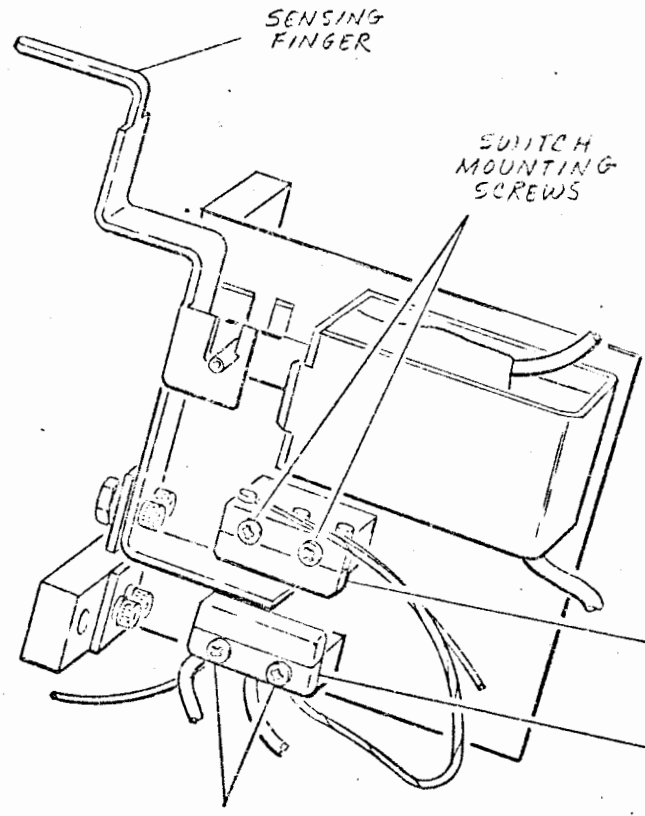

SENSING
FINGER

SWITCH
MOUNTING
SCREWS

SWITCH S1
ENERGIZES
SOLENOID

S2

SWITCH
MOUNTING
SCREWS

Figure 8-1(A). Write Enable Switch (07970-60150)

bet c. Be sure that all screws are tight prior to final confirmation of a and b. Repeat
cor adjustment for all three limit switches. If background noise permits, switch operation can
pe: ohmmeter is used be sure that power is not applied to the tape unit.

t and b. Re-
ts, switch

operation can be checked audibly, otherwise connect a suitable ohmmeter across
the switch terminals. If ohmmeter is used be sure that power is not applied to the
tape unit.

8-12. WRITE ENABLE SWITCH POSITION. The write enable switch must be positioned to assure clearance when
operated with a reel that does not have the write enable ring installed (Reel is "File Protected") and to assure both
retraction and operating clearance when used with a reel that has the "Write Enable" ring installed. These conditions
will be established when the proper dimensional relationships exist between the write enable sensing finger and the
outer face of the reel turntable. To obtain these required dimensional relationships, perform the adjustment procedure
in the order indicated (See Figure 8-1(A) and Figure 12-5):

a. Sensing Finger - Turntable Face Adjustment.

1. Loosen S1 switch mounting screws (2).
2. With the solenoid de-energized, adjust S1 until the write enable finger extends 1/8" beyond the turntable face.
3. Tighten mounting screws.

b. Sensing Finger - Solenoid Travel Adjustment.

1. Loosen Solenoid Frame mounting screws.
2. Energize solenoid.
3. Adjust solenoid frame until the write enable finger is retracted approximately 1/8" from the face of the turntable.
4. Tighten solenoid frame mounting screws.
5. Verify that the total finger travel (solenoid energized vs de-energized state) is $1/4 \pm 0.020$ inch.

c. S2 Switch Position Adjustment.

1. Loosen S2 switch mounting screws (2).
2. Energize solenoid.
3. Position S2 switch body so that the switch is tripped with the solenoid bottomed-out.
4. Tighten switch mounting screws (2).

8-13. 8-13. REEL RETAINING KNOB: This adjustment is made at the factory but will
will not require some correction during the life of the reel motor. When the locking lever is working
develop properly, it should be possible to place the reel over the rubber with a very minimum of
this contact interference. When the locking lever is closed, positive resistance should be encountered as
turntable the rubber is compressed. In the locked position, it should not be possible to move the
be positioned the reel by hand. If slippage is suspected, place a piece of masking tape on the reel, another
(Locking turntable aligned by more than 1/8" in 16 hours of operation. To correct tape reel slippage, release
locked locking lever and loosen the pozdriv screw, rotate the Reel Retainer Knob clockwise and
turntable tighten screw. Repeat until tape reel mounts firmly and does not slip.

actory
uble de-
peration,
en the
y it should
rference
o the
the
ct to the

bet c. Be sure that all screws are tight prior to final confirmation of a and b. Repeat
 cor adjustment for all three limit switches. If background noise permits, switch operation can
 be checked audibly, otherwise connect a suitable ohmmeter across the switch terminals. If
 ohmmeter is used be sure that power is not applied to the tape unit.

stopped

t and b. Re-
ts, switch

operation can be checked audibly, otherwise connect a suitable ohmmeter across
 the switch terminals. If ohmmeter is used be sure that power is not applied to the
 tape unit.

8-12. WRITE ENABLE SWITCH POSITION. The write enable switch must be positioned to assure clearance when
 operated with a reel that does not have the write enable ring installed (Reel is "File Protected") and to assure both
 retraction and operating clearance when used with a reel that has the "Write Enable" ring installed. These conditions
 will be established when the proper dimensional relationships exist between the write enable sensing finger and the
 outer face of the reel turntable. To obtain these required dimensional relationships, perform the adjustment procedure
 in the order indicated (See Figure 8-1(A) and Figure 12-5):

a. Sensing Finger - Turntable Face Adjustment.

1. Loosen S1 switch mounting screws (2).
2. With the solenoid de-energized, adjust S1 until the write enable finger extends 1/8" beyond the
turntable face.
3. Tighten mounting screws.

b. Sensing Finger - Solenoid Travel Adjustment.

1. Loosen Solenoid Frame mounting screws.
2. Energize solenoid.
3. Adjust solenoid frame until the write enable finger is retracted approximately 1/8" from the
face of the turntable.
4. Tighten solenoid frame mounting screws.

5. Veril d. Sensing Finger - Reel Turntable Flange Diameter Clearance Adjustment.

c. S2 Switch

1. Loos
2. Ener
3. Positi
4. Tighten switch mounting screws (2).
1. Loosen write enable frame mounting screws (3).
2. Position frame so that the sensing finger will clear the reel flange diameter throughout solenoid
travel.
3. Tighten frame mounting screws (3).

8-13. REEL RETAINING KNOB: This adjustment is made at the factory but will
 require some correction during the life of the reel motor. When the locking lever is working
 properly, it should be possible to place the reel over the rubber with a very minimum of
 interference. When the locking lever is closed, positive resistance should be encountered as
 the rubber is compressed. In the locked position, it should not be possible to move the
 reel by hand. If slippage is suspected, place a piece of masking tape on the reel, another
 on the hub. A mark placed in alignment on both pieces of tape should not become mis-
 aligned by more than 1/8" in 16 hours of operation. To correct tape reel slippage, release
 locking lever and loosen the pozidriv screw, rotate the Reel Retainer Knob clockwise and
 tighten screw. Repeat until tape reel mounts firmly and does not slip.

actory
 ible de-
 peration,
 en the
 y it should
 rference
 o the
 the
 ct to the

TEMPORARY CHANGE PAGE

Product

MODEL: 7970A Magnetic Tape Unit
SERIAL PREFIX ~~XXXXXXXXXX~~ 1026A

Date of Change:

29 July 1970

Literature

TITLE: Operating and Service Manual
DOCUMENT NO: 07970-90620
ISSUE/DATE: Preliminary/July 1970

This temporary change page replaces information on page 8-4 as follows:

Delete: Paragraph 8-15, a, b, c, and d.

Add:

8-15. REEL SERVO ARM OPERATING POSITION AND PHOTOCCELL/MASK ADJUSTMENT. The reel servo arm photosense mask is adjusted so that the normal tensioned position of the arm will be in the center of the operating range. Position marks have been provided on the rear side of the casting for this purpose. After this centering adjustment, the voltage output from the photocell is checked with full arm swing and adjusted if required. Adjustment is performed as follows:

- a. The power switch must be ON with no tape threaded on the transport.
- b. While holding the upper tension arm away from the limit switch, press the LOAD pushbutton. This will cause the reel motors to start turning.
- c. Manually hold the servo arm in the correct position as viewed from the back of the transport; loosen the center mounting screw for the Photosense mask and rotate the mask until the reel motor stops operating. Rotation of the motor is visible through the opening in the rear of the reel motor case. Tighten mask mounting screw.
- d. Repeat the adjustment for both motors and make a final check by loading tape. With tape loaded, both motors should be stopped with the arms positioned opposite the location marks. If necessary a final adjustment can be made with the tape loaded. Be careful to manually hold the arm when loosening or tightening the mask holding screw. With the screw slightly loose the mask may be carefully rotated until the arm position is achieved. Again hold the arm by hand while re-tightening the mask position locking screw.

Place this temporary change page immediately preceding affected page.

TEMPORARY CHANGE PAGE

Product

MODEL: 7970A Magnetic Tape Unit
SERIAL PREFIX ~~XXXXXXXX~~: 1026A

Date of Change:

29 July 1970

Literature

TITLE: Operating and Service Manual
DOCUMENT NO: 07970-90620
ISSUE/DATE: Preliminary/July 1970

This temporary change page replaces information on page 8-5 as follows:

Delete paragraph at top of page.

Add the following steps to Paragraph 8-15, starting on page 8-4.

e. The output voltage from the photocell (measured at the input test point on the Reel Servo Board) should make a $2.0 \frac{+0.1}{-0.0}$ volts change when the arm is swung through its full travel. To increase the voltage swing (change), loosen the tension arm board assembly mounting screws and move the photocell closer to the mask. Move the photocell away from the mask to reduce the voltage swing (change).

f. Recheck arm centering per step d, page 8-4.



Place this temporary change page immediately preceding affected page.

opposite the location marks. If necessary a final adjustment can be made with the tape loaded. Be careful to manually hold the arm when loosening or tightening the mask holding screw. With the screw slightly loose the mask may be carefully rotated until the arm position is achieved. Again hold the arm by hand while retightening the mask position locking screw.

8-16. PHOTONSENSE HEAD POSITION. The photosense position is adjusted so that the face is parallel to the tape path and approximately 1/8 inch from the tape with the tape in the normal LOAD and tensioned position. The position is not critical and is adjusted as follows:

- a. Load tape on the transport in normal manner.
- b. If head is out of position, loosen mounting screws on rear of transport and reposition head. Tighten all screws.

8-17. Regulated Power Supplies Adjustment

8-18. Only one adjustment is provided to cover the three regulated supplies. The adjustment control is located in the circuitry for the +12 Volt supply, but is adjusted to establish the value of the +5 Volt supply which is held to a tighter operating tolerance. The value of the +12 and -12 supplies is established by precision resistor network. The control is located on the power regulator card.

8-19. Voltage is correctly adjusted when the following conditions are met.

+5 Volts	$\pm 1\%$ ($\pm .050$ Vdc)	*Adjust to $\pm .010$ Vdc when adjustment is required.
+12 Volts	$\pm 3\%$ ($\pm .360$ Vdc)	
-12 Volts	$\pm 3\%$ ($\pm .360$ Vdc)	

8-20. Capstan Servo Electrical Adjustment

8-21. Prior to making capstan servo adjustment it is important that the power supply adjustments be verified. It is also essential that the following adjustments be made in the order indicated as there is interdependence and interaction. All adjustments should be rechecked after completing the last adjustment (FWD Start RAMP Slope, paragraph 8-29.)

8-22. CAPSTAN MOTOR OFFSET CURRENT. Connect a suitable DC Voltmeter (capable of resolution to ± 5 Mv DC) across the 3 ohm 1% resistor comprised of R21 and R22 connected in series with the capstan motor. The common side of the

resistor is associated with pin 2 of CJ1 and the high or motor side is associated with pin 2 of CJ2.

8-23. Load the tape transport and be sure tape is stopped. Adjust OFFSET control until voltmeter reading is minimum. An acceptable minimum is any value which is between +0.100 VDC and -0.100 VDC. Typical adjustment at room ambient temperature (25 degrees C) will be in the order of ± 0.050 VDC. Adjust if greater than ± 0.080 VDC.

8-24. HIGH SPEED FORWARD & REWIND. Accurate adjustment is based on reading (into a computer) data bits that have been recorded with high average accuracy. HP Test Tapes 5950-4526 and 5950-4525 have bit to bit accuracy of better than 0.1% when measured over a distance of 2000 bits or more. The tapes include a variety of data and are provided in both 7 and 9 track formats. In using these tapes it is important to recognize that there are two data bits for each cycle counted by the counter when the counter is connected to the preamplifier analog output signal, and also that the frequency at other than the specified tape speeds may be calculated on a direct ratio basis.

8-25. Complete data location tables are included with the tapes. The data location used in adjusting the 7970A is on Channel 3 which provides a signal of 10,000 Hz at a tape speed of 30 ips and has a bit-to-bit distance of .0015 inch.

8-26. High Speed Forward Adjustment (+160) is made as follows:

a. Load the test tape (5950-4526 for 9 tracks) or (5950-4525 for 7 tracks) on the transport and connect a counter to Channel 3 Preamplifier output. This signal is on Channel 3 for both the seven and nine track units.

b. Place unit in high speed forward with the +160 service switch, and use the +160 Adjustment to adjust speed until counter reads 53,333 Hz ± 100 Hz. No adjustment is required if counter reads between 52,533 and 54,133 Hz ($\pm 1.5\%$).

8-27. Rewind (High Speed Reverse) adjustment is made as follows:

a. Adjustment is identical to the High Speed Forward Adjustment except the local REWIND control is used to place unit in rewind mode and the -160 Adjustment control is used. Counter readings are to be identical to tolerances for high speed forward adjustment.

8-28. FORWARD AND REVERSE DRIVE SPEEDS. Requirements and principles of adjustment are the same as described in paragraphs on High Speed Forward and Rewind. The test tape data on Channel 3 (10,000 Hz at 30 ips tape speed) is the basis for the following adjustment sequence:

a. Load transport test tape and place unit in FWD drive mode using service switch provided.

resistor is associated with pin 2 of CJ1 and the high or motor side is associated with pin 2 of CJ2.

8-23. Load the tape transport and be sure tape is stopped. Adjust OFFSET control until voltmeter reading is minimum. An acceptable minimum is any value which is between +0.100 VDC and -0.100 VDC. Typical adjustment at room ambient temperature (25 degrees C) will be in the order of ± 0.050 VDC. Adjust if greater than ± 0.080 VDC.

8-24. HIGH SPEED FORWARD & REWIND. Accurate adjustment is based on reading (into a computer) data bits that have been recorded with high average accuracy. HP Test Tapes 5950-4526 and 5950-4525 have bit to bit accuracy of better than 0.1% when measured over a distance of 2000 bits or more. The tapes include a variety of data and are provided in both 7 and 9 track formats. In using these tapes it is important to recognize that there are two data bits for each cycle counted by the counter when the counter is connected to the preamplifier analog output signal, and also that the frequency at other than the specified tape speeds may be calculated on a direct ratio basis.

8-25. Complete data location tables are included with the tapes. The data location used in adjusting the 7970A is on Channel 3 which provides a signal of 10,000 Hz at a tape speed of 30 ips and has a bit-to-bit distance of .0015 inch.

8-26. High Speed Forward Adjustment (+160) is made as follows:

a. Load the test tape (5950-4526 for 9 tracks) or (5950-4525 for 7 tracks) on the transport and connect a counter to Channel 3 Preamplifier output. This signal
 ADD: Paragraph 8-26, Step c as follows:

c. If high speed search is required for 7-track Tape Units equipped with parity options, having normal drive speeds less than 15 ips, high speed mode must not exceed a factor of 12 times the normal drive speed.

the
id-

8-27. Rewind (High Speed Reverse) adjustment is made as follows:

a. Adjustment is identical to the High Speed Forward Adjustment except the local REWIND control is used to place unit in rewind mode and the -160 Adjustment control is used. Counter readings are to be identical to tolerances for high speed forward adjustment.

8-28. FORWARD AND REVERSE DRIVE SPEEDS. Requirements and principles of adjustment are the same as described in paragraphs on High Speed Forward and Rewind. The test tape data on Channel 3 (10,000 Hz at 30 ips tape speed) is the basis for the following adjustment sequence:

a. Load transport test tape and place unit in FWD drive mode using service switch provided.

b. Adjust until counter reading is correct for tape speed involved. The values for speeds of 25 ips and 37.5 ips will follow. Values for other speeds may be readily calculated by direct ratio to speed and application of the percentage tolerances indicated.

c. For 25 ips Speeds, the counter should read 8,333 Hz ± 16 Hz ($\pm 0.2\%$) when adjustment is completed. No adjustment is necessary as long as counter reading is within ± 65 Hz ($\pm 0.8\%$).

d. For 37.5 ips Speeds, the counter reading should be 12,500 Hz ± 25 Hz ($\pm 0.2\%$) at time of adjustment. No adjustment is necessary if reading is within ± 100 Hz ($\pm 0.8\%$).

e. Repeat steps a and b with unit in REV drive mode.



8-29. RAMP SLOPE. The ramp slope adjustment determines the start and stop distances for both forward and reverse drive modes. In order to maintain a symmetrical relationship for forward and reverse distances it is necessary to compensate for the inherent time constant of approximately 0.5 millisecond that exists between the issuance of a drive command and the start of any actual change in the velocity of the capstan motor. This delay does not move tape at the beginning of the start command where capstan velocity is zero; but does move tape at full capstan velocity immediately following the stop command. This compensation is accomplished as illustrated in figure 8-1. The specified start and stop times must include periods of 0.5 milliseconds with no tape motion; equal periods of acceleration or deceleration; and periods of 0.5 milliseconds of operation at full drive speed. Adjustment sequence is as follows:

a. Load tape having all ones at 800 BPI, or generate such a tape as required. The tape used for speed tests is also acceptable for this test. Channel 3 output can continue to be used.

b. Connect oscilloscope to utilize external sync from the drive command (The equipment referenced in paragraph 8-6a will provide this sync, as well as the dynamic programming that will be required). Connect the display to the preamplifier output of Channel 3 (if transport test tape is used).

c. Operate transport in steady state forward drive and observe the steady state maximum analog output level from the preamplifier. Adjust scope as required to locate this 100% level for positive identification under dynamic programming.

d. Operate transport in dynamic forward drive mode with drive times long enough to go well beyond the specified start times.

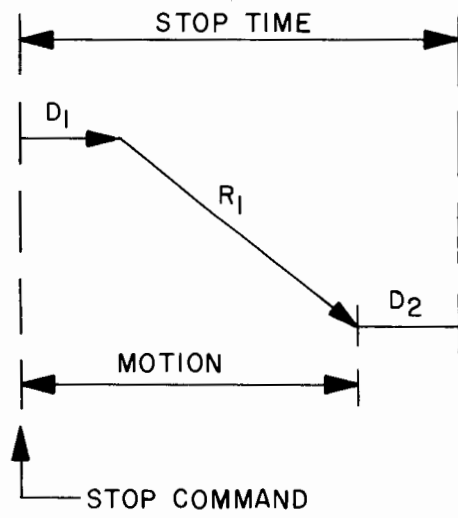
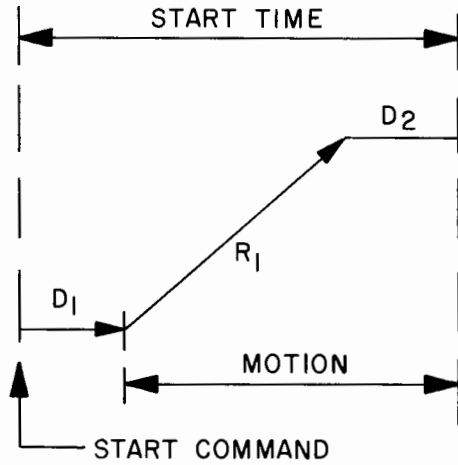

DI REPRESENTS THE INHERENT DELAY.
RI REPRESENTS THE RAMP TIME.
D2 EQUALS DI AND IS INCLUDED FOR COMPENSATION.

7970-A-33

Figure 8-1. Start/Stop Time

- e. Observe the point in time (following a forward start command) when the output level first reaches the steady state maximum established in (c).
- f. Adjust RAMP control so that this point is 0.5 millisecond less than the start time specified for the tape speed of the transport. No readjustment is necessary if this point is between 0.4 and 0.6 millisecond less than the start time.
- g. The specified start and stop times for 25 ips and 37.5 ips are respectively 15 milliseconds and 10 milliseconds. Other speed times may be calculated using the formula $T_S = 375/V$ (Where T_S is the specified start/stop time in milliseconds; 375 is a constant; and V is tape speed in ips).
- h. The 100% adjustment times (based on $T_S - 0.5$) in milliseconds for the 25 ips and 37.5 ips units are as follows:
 - i. 100% amplitude for 25 ips units should be adjusted to 14.5 milliseconds.
 - j. 100% amplitude for 37.5 ips units should be adjusted to 9.5 milliseconds.

8-30. Read Data Electronics Adjustments

Revised Paragraph 8-31.

8-31. PREAMPLIFIER GAIN. The gain/bandwidth characteristics of the preamplifier will cause small changes in phase that will effect the static skew compensation if the preamplifier gain control is adjusted. Therefore, it must be adjusted prior to the read static skew compensation, and if changed, the read static skew adjustment should be rechecked. Adjustment is made as follows:

- a. Preamp Gain Adjustment - Read Only Equipped Tape Units. (With A Single 7- or 9-Track Head).
 - 1. Preferred Method Where a Read-After-Write Equipped Tape Unit Is Available:
 - (1) Load the write test tape specified in Paragraph 8-6c and place the Tape Unit in write mode and write a full reel of all "ones" data at 200 bpi density. DO NOT REWIND.
 - (2) Transfer the test tape to the Read Only Tape Unit.
 - (3) Read the tape in reverse.
 - (4) Adjust preamp gain pots for an average peak-to-peak output of $6.4 \pm 0.2V$.
 - 2. Test Method Utilizing A Reference Amplitude Test Tape:
 - (1) Load the test tape specified in Paragraph 8-6d.
 - (2) Operate the Tape Unit in read mode.
 - (3) Adjust preamp gain pots to obtain the average peak-to-peak preamp output voltage specified on the test tape reel tolerance specification, $\pm 0.2 V PP$.
- b. Preamp Gain Adjustment - Tape Units Equipped With Dual, 7- And 9-Track Heads (Read/Read Tape Units).



1. Nine-Track Mode Gain Adjustment:
 - (1) Select 9-Track operation.
 - (2) Adjust the nine preamp gain pots using the procedure outlined in Paragraph 8-31a, Procedure "1" or "2".
2. Seven Track Mode Gain Adjustment (use one of the two indicated procedures which follow):
 - (1) Reference Amplitude Test Tape Procedure.
 - (a) Select 7-Track operation.
 - (b) Perform procedure indicated in Paragraph 8-31a, 2.
 - (2) IBM 800 BPI Master Alignment Tape Procedure.
 - (a) Adjust the 9-Track preamplifiers as indicated in 8-31b, 1.
 - (b) Install IBM Master Alignment Tape (refer to Paragraph 8-6a).
 - (c) Select 9-Track operation and observe 9-Track output signal amplitudes while reading the IBM Master Alignment Tape.
 - (d) Select 7-Track operation and adjust preamp gain pots to obtain the same peak-to-peak output observed in 9-Track operation.

NOTE

Alignment tapes that have been passed over 9-Track write heads may suffer some signal degradation due to residual flux from the write heads; consequently, the signal amplitude will be different in the 7-Track tape zones. Therefore use only relatively new tape that has not been read on Read-After-Write Tape Units.

skew test point, in turn, and observe the relationship between the P channel skew delay (trailing edge) and the other delay.

f. Each time that the channel under test is greater than the P channel delay (occurs to right of P channel trailing edge on scope), readjust the P channel FWD skew delay so that the P channel is later (by a time equal to approximately 25 micro-inches at the tape speed involved) and continue observation. When completed, there is assurance that the P channel is latest (by approximately 25 microinches).

NOTE

The purpose of the above steps is to assure that there need be only one pass through the skew delay adjustment process and also to assure that the skew delay adjustment uses the earliest portion of the available adjustment range to accomplish this compensation. Proceed with finalizing the adjustments with steps g thru j.

8-32. FORWARD STATIC SKEW COMPENSATION. The technique for rapid adjustment and the technique for evaluating the need for adjustment differ. To adjust static skew compensation proceed as follows:

- a. Load the IBM Master Alignment Tape (refer to paragraph 8-6a) and place Unit in forward steady state drive mode during any adjustment operation.
- b. Preset all skew delay controls fully CCW (minimum delay position).
- c. Select one track (Channel P) for reference and connect scope channel A to the FWD SKEW test point on Channel P read card.
- d. Sync scope on negative slope (to trailing edge of waveform) and adjust sweep to present the next skew delay waveform near center of scope screen.
- e. Using the "Chopped Mode" connect the B channel of the scope to each FWD skew test point, in turn, and observe the relationship between the P channel skew delay (trailing edge) and the other delay.
- f. Each time that the channel under test is greater than the P channel delay (occurs to right of P channel trailing edge on scope), readjust the P channel FWD skew delay so that the P channel is later (by a time equal to approximately 25 microinches at the tape speed involved) and continue observation. When completed, there is assurance that the P channel is latest (by approximately 25 microinches).

NOTE

The purpose of the above steps is to assure that there need be only one pass through the skew delay adjustment process and also to assure that the skew delay adjustment uses the earliest portion of the available adjustment range to accomplish this compensation. Proceed with finalizing the adjustments with steps g thru j.

g. Adjust scope controls to present at least two and preferably three periods (bit-to-bit times) on the sweep with scope internally synched on channel A (negative slope).

h. Adjust scope gain for equal sensitivity for channels A and B and adjust for less than 50% full screen deflection for either channel separately.

i. With scope synched internally on channel A and set to A + B mode, connect channel B to each FWD Skew Test Point and adjust each track to produce maximum 0 to Peak deflection on the scope screen. If steps a thru f were accomplished satisfactorily, it should be possible to go through a maximum and beyond with each skew delay.

8-33. To check the magnitude of any error in read static skew compensation for purposes of determining the necessity for readjustment proceed as follows:

a. Utilize the delayed sweep features of the oscilloscope to observe the time difference between the various tracks. Synchronize to one of the channels and set the delaying sweep to delay the majority of the bit-to-bit time. This will permit the delayed sweep speed to be set fast enough for good resolution of the time difference of the peak signals. Comparison should be made under "Chopped" mode only.

b. If the maximum time difference between the earliest and latest bit received is not greater than the time corresponding to a distance of 50 microinches at the tape speed involved, there is no reason to readjust the skew compensation.

8-34. REVERSE STATIC SKEW COMPENSATION. Reverse static skew compensation is accomplished in exactly the same manner as that used for forward skew except for the use of reverse drive mode and adjustment of reverse skew controls. The same SKEW test points are used for both adjustments.

8-35. When considering the need for readjustment it must be recognized that there are small differences in the master skew tapes. For example, if there is an observed difference of 1 microsecond between channels, this would correspond to 25 microinches at a tape speed of 25 ips. If the previous adjustment had been made with one Master tape and checked with another, and if both master tapes were accurate to $\pm 1\%$ (± 12.5 Microinches), this small difference could occur even with complete stability of adjustment on the part of the electrical and mechanical factors involved in the tape unit.

8-36. READ CHARACTER GATE. The read character gate is adjusted to allow a period equal to 40% of the bit-to-bit distance for all of the read bits in a character to be placed in the output register. At the end of this period a read strobe occurs

which sets all read data lines. One microsecond later, a read clock is generated which lasts 2 to 3 microseconds as an output signal. The read character gate is adjusted as follows:

- a. Use the IBM Master Alignment Tape (or any conveniently available tape) and place the tape unit in the forward read mode.
- b. Synchronize the scope (negative slope) to the NOR test point on the read control card. (The first data bit of a character will start the GATE time when this line goes to ground).
- c. Observe the time to the (positive going) edge of the NOR signal.
- d. Adjust this time with the GATE adjustment control so that it corresponds to a time equal to 500 microinches of tape motion for 800 bpi density. ($T = 500/V$ where T is time in microseconds and V is the tape velocity in inches per second.) No adjustment is warranted if the gate time corresponds to a distance variation of $\pm 10\%$ (+50 microinch). Time intervals for nominal 800 bpi adjustment at 25 ips and 37.5 ips are as follows:
 - e. 25 ips Gate time should be adjusted to 20 microseconds.
 - f. 37.5 ips Gate time should be adjusted to 13.3 microseconds.
 - (1) 556 bpi gate = 720 microinches \pm 72 microinches
 - (2) 200 bpi gate = 2000 microinches \pm 200 microinches

8-37. Write Data Electronics Adjustment

8-38. The only adjustment for write data electronics is the Write Static Skew Compensation. Write static skew compensation provides additional assurance that tapes written on the unit will not have more than 150 microinches of absolute static skew in any data character. This figure applies to any data pattern condition and includes all factors that cause bits to be displaced from their theoretical locations. The objective of setting write static skew is to cause the write function of the tape unit to produce a tape which appears to be identical to the IBM Master skew tape when read on the unit. It is therefore a prerequisite that the Read Static Skew adjustment be verified prior to proceeding with the following Write Static Skew Compensation adjustments.

8-39. The equipment connections and principles of operation are identical to those used for forward read skew except that the IBM Master Alignment Tape is replaced

with a write tape that is in good mechanical condition. To adjust the write static skew compensation proceed as follows:

- a. Place unit in forward write mode of operation with a data pattern of all ones at 800 bpi. Minimize write skew delay by performing steps a thru f, paragraph 8-32.
- b. While observing the corresponding read track, adjust the write SKEW control to make sure that it is possible to go through a point of maximum output (as developed in steps g thru k, paragraph 8-32). If maximum output cannot be achieved; readjust the write SKEW control that corresponds to the read channel being used for reference and repeat all previous skew adjustments.

CAUTION

Under no circumstances are any of the read skew adjustments to be changed during the write skew compensation process.

- c. Repeat step (b) as required until all channels meet the requirement of being adjusted to point of maximum amplitude under conditions of paragraph 8-32e; and there is assurance that it is possible to go through this point with the available range in the write SKEW compensation adjustment.

8-40. Write Parity Adjustments

8-41. To be supplied.

8-42. Read Parity Adjustments

8-43. To be supplied.

8-44. ALIGNMENT PROCEDURE

8-45. To be supplied.

8-46. CALIBRATION PROCEDURE

8-47. To be supplied.

TEMPORARY CHANGE PAGE

Product

Date of Change:

PRODUCT: 7970A Magnetic Tape Unit
SERIAL PREFIX/SERIES: 1016A

21 December 1970

Technical Manual

TITLE: Operating and Service Manual
TYPE: Preliminary Instruction Manual
NO: 07970-90620 **ISSUE/DATE:** July 1970

This temporary change page affects information on page 8-14 as follows:

ADD: 8-48. TAPE DECK TAPE GUIDE LOADING PROCEDURE

8-49. Tape Guide loading is critical; Tape Guide loading must be performed whenever the tape guide is dismantled or repaired. The exploded tape guide assembly is illustrated in Figure 8-2. Numbers in parenthesis refer to page 11-9, Figure 11-2, Tape Deck Assembly (Parts List). To obtain the proper tape guide loading, proceed as follows:

- a. Assure that brass nut (8) is torqued to 5 in. lb. (torque-meter is recommended).
- b. Install assembly components as indicated in Figure 8-2. Use Retaining Ring Pliers (Waldes 18-23, Industrial Retaining Ring Corp., P100 or equivalent). Avoid distorting retaining ring.
- c. Check Tape Guide Bearing Assembly (6) end-play. Add/remove flat washers (3 or 2) until end-play is just removed.
- d. Spin bearing assembly and check for drag. The tape guide must spin freely. If the tape guide does not spin freely, loading is excessive; recheck end-play clearance.

Place this page immediately preceding or facing affected page.

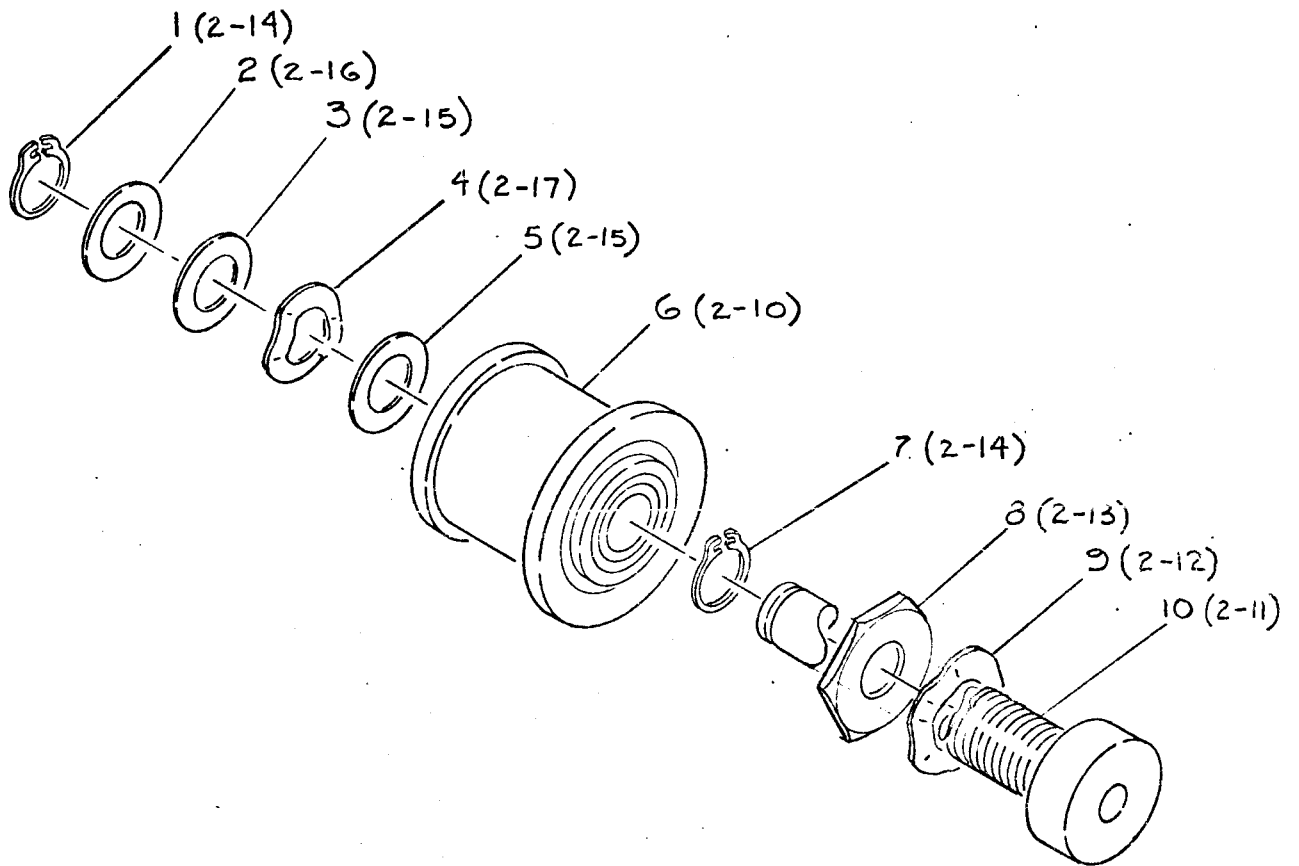

Figure 8-2. Tape Deck Tape Guide Assembly

SECTION IX
TROUBLESHOOTING

(To be supplied)



TEMPORARY CHANGE PAGE

Product

PRODUCT: 7970 MAGNETIC TAPE UNIT
SERIAL PREFIX/SERIES: 1016A

Date of Change:

29 January 1971

Technical Manual

TITLE: OPERATING AND SERVICE MANUAL
TYPE: PRELIMINARY INSTRUCTION MANUAL
NO: 07970-90620 **ISSUE/DATE:** July 1970

This temporary change page affects information on page XXX as follows:

ADD Section X, REPAIR AND REPLACEMENT, Paragraphs 10-1 through 10-10, pages 10-1 and 10-2.

Place this page immediately preceding or facing affected page.

Section X

REPAIR AND REPLACEMENT

10-1. INTRODUCTION

10-2. Repair and replacement procedures provided in this section are for Tape Unit parts or assemblies. Repair and replacement of parts should be initiated only after troubleshooting, inspection, or regular maintenance has indicated a malfunction due to excessive wear, faulty alignment of components, etc.

10-3. CAPSTAN

10-4. The Capstan Servo Assembly must be removed from the tape deck mainframe before the Capstan can be removed. For reference see Figure 1-4.

10-5. The following tools are required/desirable.

- a. 9/64 (0.141 inch) Allen Wrench
- b. 3/64 (0.047 inch) Allen Wrench
- c. Torque Wrench (2 inch-pound capability).
- d. Torque Wrench (34 inch-pound capability).
- e. 6" scale with 1/32 and 1/64 graduations.

10-6. Removal

10-7. To remove Capstan proceed as follows:

- a. Disconnect AC power cable.
- b. Open Tape Unit Cover Door.
- c. Release Tape Deck Pawl Fastener and swing Tape Deck Mainframe open.
- d. Disconnect electrical plug at CJ4, Capstan Servo Board.
- e. Disconnect electrical plug at CJ3, Capstan Servo Board.
- f. Remove Capstan Servo Assembly mounting screws (4) while supporting assembly.
- g. Place Capstan Servo Assembly on padded surface.
- h. Loosen Capstan set screws (2).
- i. Remove Capstan.

10-8. Installation

10-9. Make visual check of unit and wire assemblies. Check shaft end-play. Shaft is spring-loaded and must be free of end-play. Turn shaft and assure that bearings turn free and have no "flat" spots. A slight, even shaft "drag" is normal.

10-10. To install, proceed as follows:

- a. Position Capstan on shaft so that set screws seat in flat-machined surfaces of shaft.
- b. Lightly seat set screws (2).
- c. Position Capstan to measure $1\text{-}1/32 + 1/64$ inch from motor flange to front of Capstan.
- d. Tighten set screws to 2-inch pounds or tighten set screws until they bottom on shaft and move CW $1/8$ turn.
- e. Position Capstan Servo Assembly and install mounting screws (4) and lock washers (4).
- f. Torque mounting screws to 34-inch pounds.
- g. Connect electrical leads (2).
- h. Clean Capstan with HP Head Cleaner (HP 8500-0810). Use cleaner sparingly.
- i. Connect AC power cable.
- j. Install a reel of tape and check tape travel.

SECTION X
REPAIR AND REPLACEMENT

(To be supplied)

SECTION XI
REPLACEABLE PARTS

11-1. INTRODUCTION

11-2. This section provides information for ordering replacement parts for the Model 7970A Digital Magnetic Tape Unit manufactured by Hewlett-Packard, Mountain View Division, Mountain View, California.

11-3. This section contains group assembly parts lists, supporting illustrations, and ordering information.

11-4. GROUP ASSEMBLY PARTS LIST

11-5. The group assembly parts list presents a breakdown of all major replaceable parts of the Model 7970A Digital Magnetic Tape Unit. The information contained in the parts lists are under the following headings:

- a. Figure and Index Number
- b. Part Number
- c. Description
- d. Units per Assembly

11-6. Figure and Index Number

11-7. This column will identify the figure which illustrates each listed item and the index number which identifies the item on the illustration.

11-8. Part Number

11-9. This column will provide the Hewlett Packard part number for each item listed in the group assembly parts list.

11-10. Description

11-11. This column describes the items within the equipment. An indented column arrangement is used to show the relationship between a part and the next higher assembly. The top assembly of each listing appears in indention 1. Primary subassemblies (of the top assembly) and attaching parts appear in indention 2.

This method of indention is continued through indention 3, 4, etc. until all replaceable parts are listed. Attaching parts are listed immediately following the part they attach. Attaching parts are identified by the abbreviation (AP) enclosed in parentheses at the end of the description.

11-12. Reference designation and manufacturer information (if applicable) is also included in the description column.

11-13. Units Per Assembly

11-14. The quantity shown in this column reflects the total quantity of a part required by that parts next higher assembly. This quantity is not necessarily the total used for the complete equipment. The abbreviation AR is used to indicate usage as required of a particular item. The abbreviation REF is used to indicate that the quantity of an item used per assembly is listed in the next higher assembly of the group assembly parts list.

11-15. ORDERING INFORMATION

11-16. To order replacement parts, address the order or inquiry to the local Hewlett-Packard Sales and Service Office. (Refer to the list at the end of this manual for addresses.) Specify the following information for each part ordered.

- a. Identification of the instrument, kit, or assembly containing the part.
- b. Hewlett Packard part number for each part.
- c. Description of each part.
- d. Circuit reference designation (if applicable).
- e. Paint sensitive parts. When ordering transport parts that are paint sensitive, the MOD NUMBER (e.g., 7970 MOD XXX) must be included. The paint sensitive parts are tabulated in table 11-1.

TEMPORARY CHANGE PAGE

Product

Date of Change:

MODEL: 7970A Magnetic Tape Unit
SERIAL PREFIX ~~XXXXXX~~ **SERIES:** 1040A

21 October 1970

Literature

TITLE: Operating and Service Manual
DOCUMENT NO: 07970-90620
ISSUE/DATE: PRELIMINARY/July 1970

This temporary change page ^{adds} ~~replaces~~ information ^{to} ~~on~~ page 11-2a as follows:
 Add Table 11-1. Transport Paint Sensitive Parts.

DESCRIPTION	PART NUMBER	NO. REQD
PANEL, DOOR COVER.....	07970-00060	1
STRIP, DOOR.....	07970-00090	1
HEAD COVER.....	07970-00130	1
SWITCH COVER.....	07970-01000	1
SWITCH COVER.....	07970-01010	1
SWITCH COVER.....	07970-01020	1
SWITCH COVER.....	07970-01030	1
SWITCH COVER.....	07970-01040	1
SWITCH COVER.....	07970-01050	1
SWITCH COVER.....	07970-01060	1
SWITCH COVER.....	07970-01070	1
SWITCH COVER.....	07970-01150	1
SWITCH COVER.....	07970-01160	1
CASTING HINGE BLOCK.....	07970-20070	2
CASTING.....	07970-20270	1
COVER DOOR.....	07970-60160	1
HINGE TRANSPORT.....	07970-20470	2

Place this temporary change page immediately preceding affected page.

Model 7970A

Section XI
Preliminary

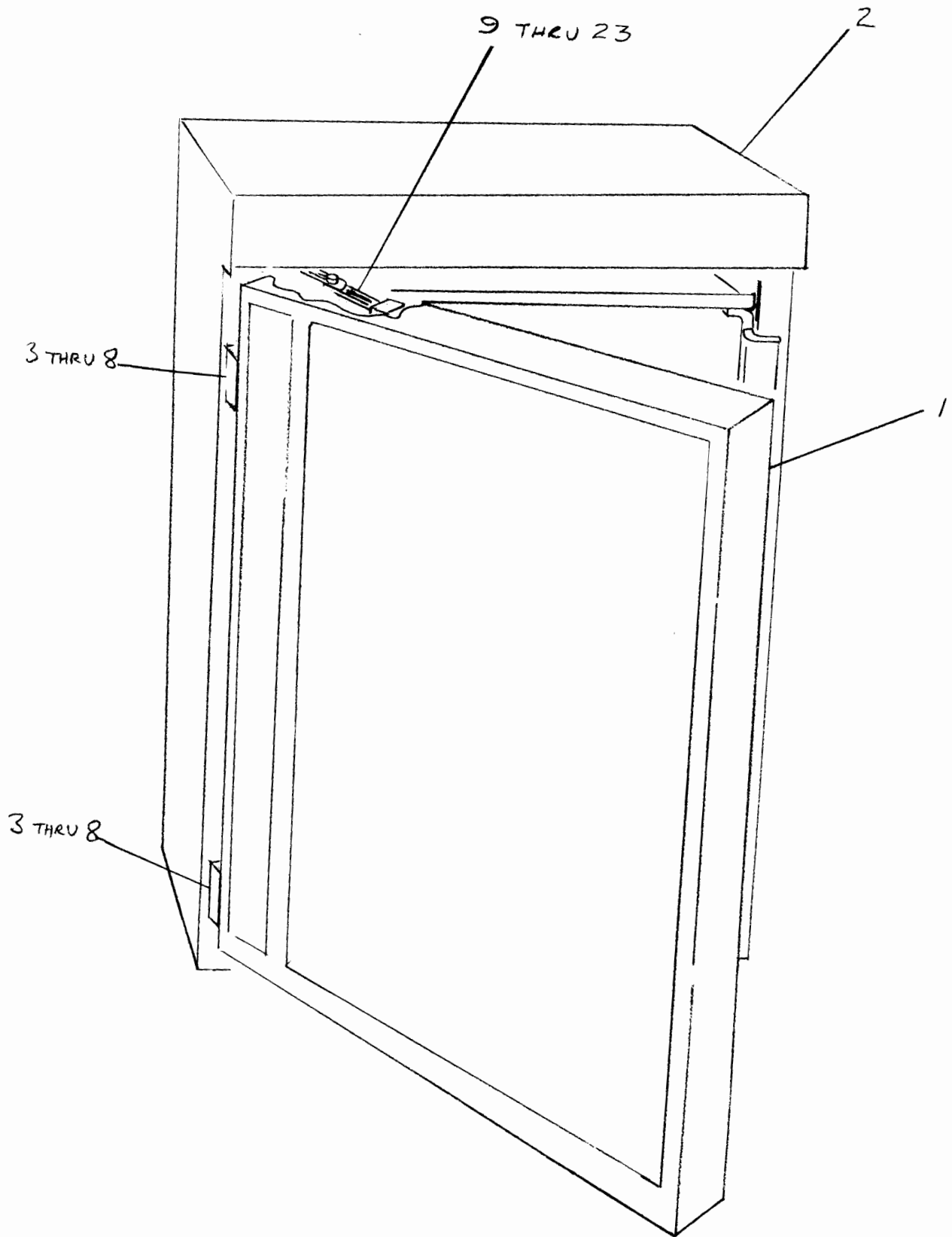

7970-A-34-1

Figure 11-1. Model 7970A Digital Magnetic Tape Unit
(Sheet 1 of 2)

7970-A-34-2

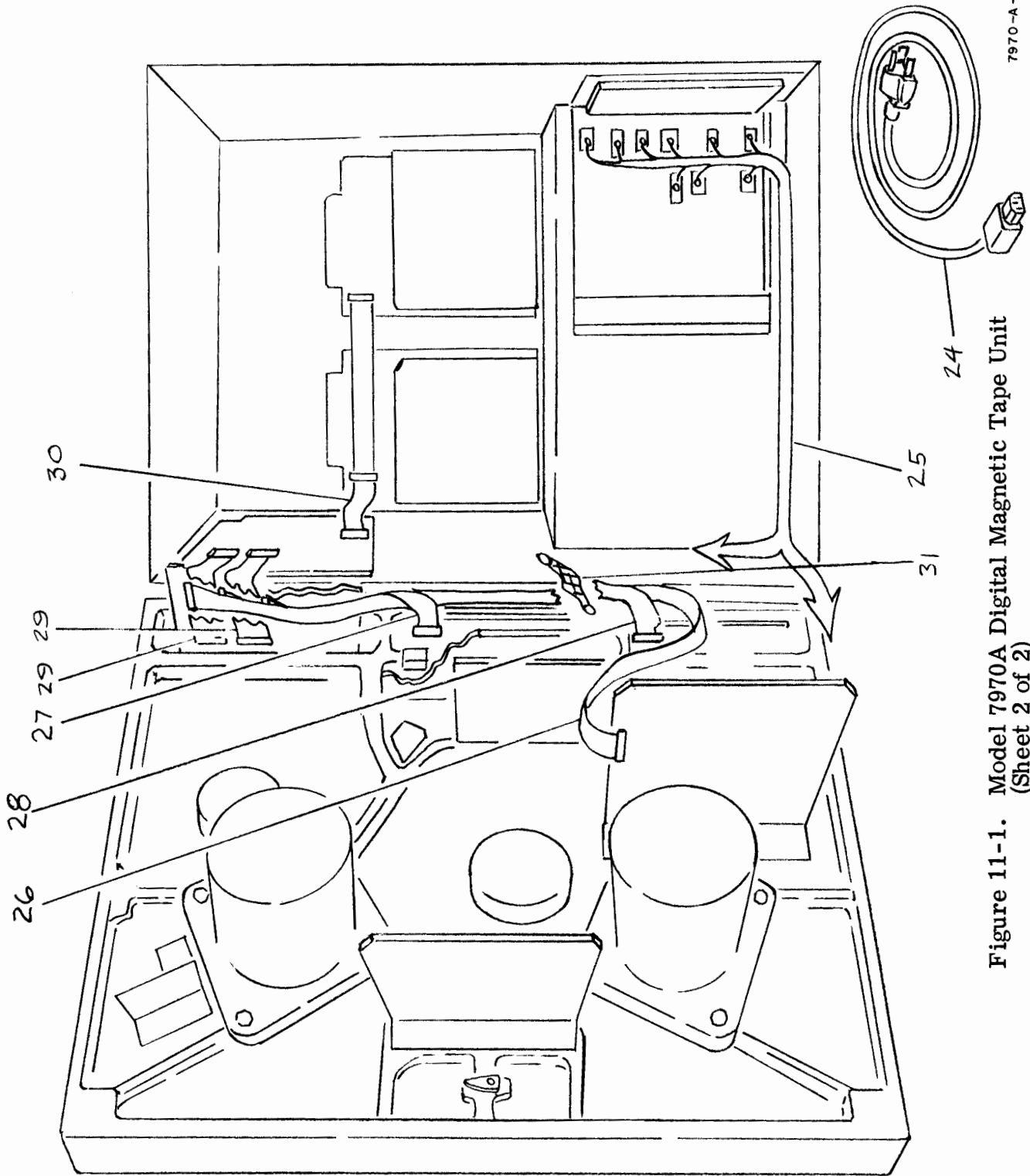
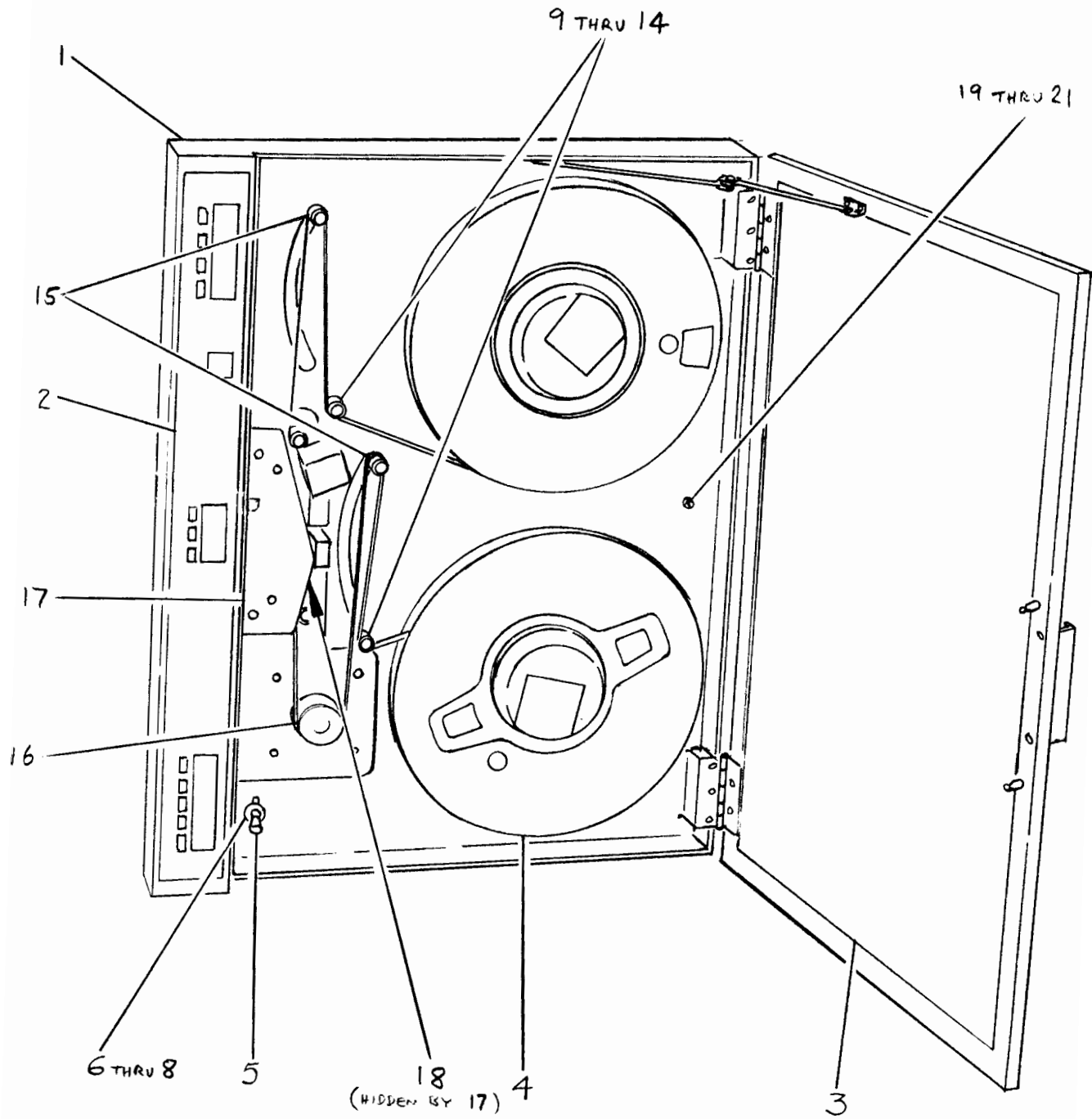

Figure 11-1. Model 7970A Digital Magnetic Tape Unit
(Sheet 2 of 2)



FIG. & INDEX NO.	PART NUMBER	DESCRIPTION				UNITS PER ASSY
		1	2	3	4	
1-	Ref. Only	7970A DIGITAL MAGNETIC TAPE UNIT				
-1	Ref. Only	. TAPE DECK ASSEMBLY (See figure 11-2)				1
-2	Ref. Only	. CABINET ASSEMBLY (See figure 11-3)				1
-3	Ref. Only	. MOUNTING HINGE ASSEMBLY				2
-4	07970-20470	. . MOUNTING HINGE				1
-5	2680-0104	. . . SCREW - Mach, 10-32 x .50 LG, 100°, FH, PHL POZI, SS				2
-6	2680-0103	. . . SCREW - Mach, SS, 10-32 x .500, PH, POZI				3
-7	07970-20070	. . MOUNTING HINGE BLOCK				1
-8	2680-0118	. . . SCREW - Mach, SS, 10-32 x .500, FH, POZI				3
-9	Ref. Only	. SLIDE HINGE ASSEMBLY				1
-10	07970-00450	. . SLIDE HINGE ARM				2
-11	2680-0105	. . . SCREW - Mach, SS, 10-32 x .625, PH, POZI				2
-12	2680-0103	. . . SCREW - Mach, SS, 10-32 x .500, PH, POZI				2
-13	2190-0034	. . . WASHER - Lock, Helical, #10, MED, SS, PASS				2
-14	3050-0002	. . . WASHER - Steel, .4375-OD, .203-ID				4
-15	2190-0475	. . . WASHER - SHLDR Nylon, .195-ID, .399-OD, .290-LG				8
-16	3050-0006	. . . WASHER - EXTRU Fibre, .5-OD, .0625-T				2
-17	0590-0050	. . . NUT - Lock, 10-32-UNF-3B, .172-HT				2
-18	07970-20120	. . SLIDE HINGE BLOCK, Tape Deck				1
-19	2680-0065	. . . SCREW - Mach, SS, 10-32 x 1.25, PH, POZI				2
-20	2190-0034	. . . WASHER - Lock, Helical, #10, MED, SS, PASS				2
-21	07970-20140	. . SLIDE HINGE BLOCK, CABINET				1
-22	2680-0099	. . . SCREW - Mach, SS, 10-32 x .375, PH, POZI				2
-23	2190-0034	. . . WASHER - Lock, Helical, #10, MED, SS, PASS				2
-24	8120-1395	. CABLE ASSEMBLY, Power (W1)				1
-25	---	. HARNESS ASSEMBLY, Tape Unit (W2)				1
-26	07970-60610	. CABLE ASSEMBLY, Capstan (W3)				1

FIG. & INDEX NO.	PART NUMBER	DESCRIPTION				UNITS PER ASSY
		1	2	3	4	
1-27	07970-60620	.	CABLE ASSEMBLY,	Density Select	(W4)	1
-28	07970-60630	.	CABLE ASSEMBLY,	Unit Select	(W5)	1
-29	07970-60880	.	CABLE ASSEMBLY,	Motion Control	(W6, W7)	2
-30	07970-60890	.	CABLE ASSEMBLY,	Read Only Data	(W8)	1
	07970-60900	.	CABLE ASSEMBLY,	Write/Read Data	(W8)	1
-31	07970-00510	.	BONDING STRAP,	Deck-to-Cabinet Ground	(W9)	1



7970-A-35-1

Figure 11-2. Tape Deck Assembly (Sheet 1 of 2)

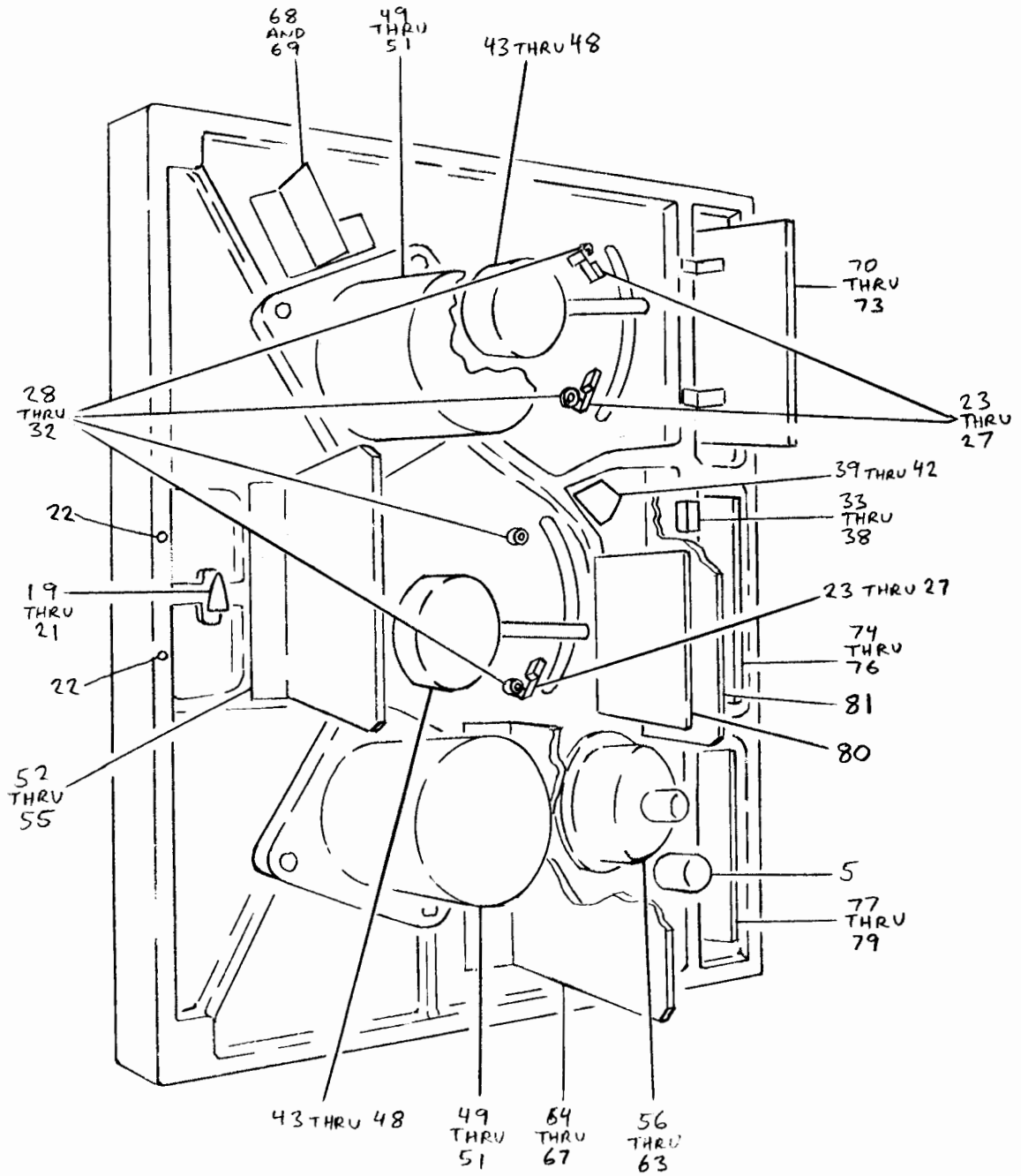

7970-A-35-2

Figure 11-2. Tape Deck Assembly (Sheet 2 of 2)

FIG. & INDEX NO.	PART NUMBER	DESCRIPTION				UNITS PER ASSY
		1	2	3	4	
2-	Ref. Only	TAPE DECK ASSEMBLY				
-1	07970-20270	. MAINFRAME, Tape Deck				1
-2	07970-01000	. SWITCH COVER, Control, Write Enable, Density Select, Unit Select				1
	07970-01010	. SWITCH COVER, Control, Write Enable, Density Select				1
	07970-01020	. SWITCH COVER, Control, Write Enable, Unit Select				1
	07970-01030	. SWITCH COVER, Control, Write Enable				1
	07970-01040	. SWITCH COVER, Control, Density Select, Unit Select				1
	07970-01050	. SWITCH COVER, Control, Density Select				1
	07970-01060	. SWITCH COVER, Control, Unit Select				1
	07970-01070	. SWITCH COVER, Control				1
	07970-01150	. SWITCH COVER, Blank				1
-3	07970-20270 60760	. COVER DOOR ASSEMBLY				1
-4	1490-0738	. MAGNETIC TAPE REEL, Empty				1
-5	---	. SWITCH, On-Off (A19A1W1S1)				1
-6	7122-0006	. . INDICATOR PLATE, On-Off Switch				1
-7	2190-0037	. . WASHER - Lock, #6, Helical, Spring Type, SS				1
-8	0590-0012	. . NUT - Knurled, 15/32-32, UNS-2B, .6-OD				1
-9	Ref. Only	TAPE GUIDE ASSEMBLY, Tape Deck				2
-10	07970-60130	. . BEARING ASSEMBLY, Tape Guide				1
-11	07970-20460	. . MOUNTING SHAFT, Tape Guide				1
-12	3050-0424	. . WASHER, SPG, Wavy, 260-27 ID, 490-510 OD, Spring Stl.				1
-13	2950-0036	. . NUT, Brass, .25-28 x .4375				1
-14	0510-0238	. . RING, Retaining				2
-15	3050-0032	. . WASHER, Brass, .3125 OD .189 ID, .010 THK				A/R
-16	2190-0181	. . WASHER, SS, .191 ID .311 OD, .005 THK.				A/R
-17	3050-0253	. . WASHER, SS, .205 ID .307 OD, Wavy				1
		(A3A1, A4A1)				4
-16	---	. CAPSTAN ASSEMBLY (A8A2)				1
-17	07970-00130	. TAPE HEAD COVER				1
-18	07970-60580	. TAPE HEAD ASSEMBLY, Write/Read/Erase, 9-Track, 20-37-1/2 IPS (A1)				1
	07970-60581	. TAPE HEAD ASSEMBLY, Write/Read/Erase, 7-Track, 20-37-1/2 IPS (A1)				1

FIG. & INDEX NO.	PART NUMBER	DESCRIPTION				UNITS PER ASSY
		1	2	3	4	
2-18	07970-60582	.	TAPE HEAD ASSEMBLY, Read Only, 9-Track, 20-37-1/2 ips (A1)			1
	07970-60583	.	TAPE HEAD ASSEMBLY, Read Only, 7-Track, 20-37-1/2 ips (A1)			1
	07970-60589	.	TAPE HEAD ASSEMBLY, Read/Read, 7/9-Track, 20-37-1/2 ips (A1)			1
	07970-60585	.	TAPE HEAD ASSEMBLY, Write/Read/Eraser 9-Track, 10-20 ips (A1)			1
	07970-60584	.	TAPE HEAD ASSEMBLY, Write/Read/Eraser 7-Track, 10-20 ips (A1)			1
	07970-60587	.	TAPE HEAD ASSEMBLY, Read Only, 9-Track, 10-20 ips (A1)			1
	07970-60586	.	TAPE HEAD ASSEMBLY, Read Only, 7-Track, 10-20 ips (A1)			1
	07970-60588	.	TAPE HEAD ASSEMBLY, Read/Read, 7/9-Track, 10-20 ips (A1)			1
-19	1390-0174	.	PAWL FASTENER, Tape Deck			1
-20	2200-0141	.	SCREW - Mach, SS, 4-40 x .312, PH, POZI			2
-21	2190-0003	.	WASHER - Lock, Helical, #4, Heavy, SS, PASS			2
-22	4320-0206	.	RUBBER PAD, Round			2
-23	---	.	SWITCH, Tension Arm Limit (W2S2, W2S3, W2S4)			3
-24	07970-00120	.	BRACKET, Tension Arm Limit Switch			3
-25	2680-0099	.	SCREW -			3
-26	2190-0034	.	WASHER -			3
-27	3050-0002	.	WASHER -			3
-28	0403-0163	.	BUMPER STOP, Tension Arm Limit			4
-29	2680-0103	.	SCREW -			4
-30	2190-0034	.	WASHER -			4
-31	3050-0002	.	WASHER -			4
-32	0380-0004	.	SPACER -			4
-33	07970-00200	.	BRACKET, Interlock Switch (Option)			1
-34	2200-0139	.	SCREW -			3
-35	2190-0003	.	WASHER -			3
-36	2680-0129	.	SCREW -			2
-37	2190-0034	.	WASHER -			2
-38	3050-0002	.	WASHER -			2

TEMPORARY CHANGE PAGE

Product

Date of Change:

PRODUCT: 7970A MAGNETIC TAPE UNIT
SERIAL PREFIX/SERIES: 1016A

14 December 1970

Technical Manual

TITLE: OPERATING AND SERVICE MANUAL
TYPE: PRELIMINARY INSTRUCTION MANUAL
NO: 07970-90620 **ISSUE/DATE:** July 1970



This temporary change page affects information on page 11-10 as follows:

DELETE:

FIGURE & INDEX NO.	PART NUMBER	DESCRIPTION				UNITS PER ASSY
		1	2	3	4	
2-33	07970-00200	. BRACKET, Interlock Switch (Option)				1
-34	2200-0139	.. SCREW				3
-35	2190-0003	.. WASHER				3
-36	2680-0129	.. SCREW				2
-37	2190-0034	.. WASHER				2
-38	3050-0002	.. WASHER				2

ADD:

2-33	07970-90600	. INTERLOCK SWITCH, Cover Door (Option)				1
	07970-61030	.. Switch Assembly				1
	2680-0129	... Screw, Mach., 10-32 x 3/16				2
	2190-0034	... Washer, Lock				2
	3050-0002	... Washer, Flat, No. 10				2

Place this page immediately preceding or facing affected page.



FIG. & INDEX NO.	PART NUMBER	DESCRIPTION				UNITS PER ASSY
		1	2	3	4	
2-39	07970-60070	.				1
-40	2200-0141	.	.		SCREW -	2
-41	2190-0003	.	.		WASHER -	2
-42	3050-0105	.	.		WASHER -	2
-43	07970-60180	.			TENSION ARM ASSEMBLY (A3, A4)	2
-44	3030-0216	.	.		SCREW -	3
-45	2190-0034	.	.		WASHER -	3
-46	3050-0065	.	.		WASHER -	3
-47	07970-60130	.	.		BEARING ASSEMBLY, Tension Arm (A1)	1
-48	07970-60480	.	.		TENSION ARM PCB SUBASSEMBLY (A2)	1
-49	07970-60170	.			REEL MOTOR ASSEMBLY (A5, A6)	2
-50	0570-0082	.	.		SCREW -	4
-51	2190-0432	.	.		WASHER -	4
-52	07970-60030	.			REEL SERVO PCB ASSEMBLY (A7)	1
-53	2680-0103	.	.		SCREW -	3
-54	3190-0034	.	.		WASHER -	3
-55	3050-0002	.	.		WASHER -	3
-56	07970-60930	.			CAPSTAN SERVO ASSEMBLY (A8)	1
-57	2680-0103	.	.		SCREW -	3
-58	2190-0034	.	.		WASHER -	3
-59	3050-0002	.	.		WASHER -	3
-60	07970-20390	.	.		CAPSTAN SUBASSEMBLY (A8A1)	1
-61	07970-60140	.	.		CAPSTAN MOTOR SUBASSEMBLY (A8A2)	1
-62	3030-0047	.	.	.	SCREW -	4
-63	2190-0429	.	.	.	WASHER -	4
-64	07970-60040	.			CAPSTAN SERVO PCB ASSEMBLY (A9)	1
-65	2680-0103	.	.		SCREW -	3
-66	2190-0034	.	.		WASHER -	3
-67	3050-0002	.	.		WASHER -	3
-68	07970-60150	.			WRITE ENABLE ASSEMBLY (A10)	1
-69	07970-60490	.	.		WRITE ENABLE DIODE SUBASSEMBLY (A10A1)	1
-70	07970-60931	.			CONTROL SWITCH ASSEMBLY, Vertical (A11)	1
-71	07970-60080	.	.		CONTROL SWITCH PCB SUBASSEMBLY (A11A1)	1

FIG. & INDEX NO.	PART NUMBER	DESCRIPTION				UNITS PER ASSY
		1	2	3	4	
2-72	07970-60340	.	.	CONTROL SWITCH LENS BLOCK SUB- ASSEMBLY, Vertical (A11A2)	1	
-73	07970-60932	.	.	WRITE ENABLE LENS BLOCK SUB- ASSEMBLY, Vertical (A11A3)	1	
	07970-60933	.		CONTROL SWITCH ASSEMBLY, Hori- zontal (A11)	1	
	07970-60080	.	.	CONTROL SWITCH PCB SUBASSEMBLY (A11A1)	1	
	(Not Assigned)	.	.	CONTROL SWITCH LENS BLOCK SUB- ASSEMBLY, Horizontal (A11A2)	1	
	07970-60934	.	.	WRITE ENABLE LENS BLOCK SUB- ASSEMBLY, Horizontal (A11A3)	1	
-74	07970-60935	.		DENSITY SELECT ASSEMBLY, Vertical (A12)	1	
-75	07970-60090	.	.	DENSITY SELECT PCB SUBASSEMBLY (A12A1)	1	
-76	07970-60350	.	.	DENSITY SELECT LENS BLOCK SUB- ASSEMBLY, Vertical (A12A2)	1	
	07970-60936	.		DENSITY SELECT ASSEMBLY, Hori- zontal (A12)	1	
	07970-60090	.	.	DENSITY SELECT PCB SUBASSEMBLY (A12A1)	1	
	(Not Assigned)	.	.	DENSITY SELECT LENS BLOCK SUB- ASSEMBLY, Horizontal (A12A2)	1	
-77	07970-60937	.		UNIT SELECT ASSEMBLY, Vertical (A13)	1	
-78	07970-60100	.	.	UNIT SELECT PCB SUBASSEMBLY (A13A1)	1	
-79	07970-60360	.	.	UNIT SELECT LENS BLOCK SUB- ASSEMBLY, Vertical (A13A2)	1	
	07970-60938	.		UNIT SELECT ASSEMBLY, Horizontal (A13)	1	
	07970-60100	.	.	UNIT SELECT PCB SUBASSEMBLY (A13A1)	1	
	(Not Assigned)	.	.	UNIT SELECT LENS BLOCK SUB- ASSEMBLY, Horizontal (A13A2)	1	
-80	07970-60300	.		WRITE HEAD INTERCONNECT PCB ASSEMBLY (A14)	1	
-81	07970-60500	.		READ HEAD PREAMPLIFIER PCB ASSEMBLY, 10-20 ips (A15)	1	
	07970-60510	.		READ HEAD PREAMPLIFIER PCB ASSEMBLY, 20-37-1/2 ips (A15)	1	

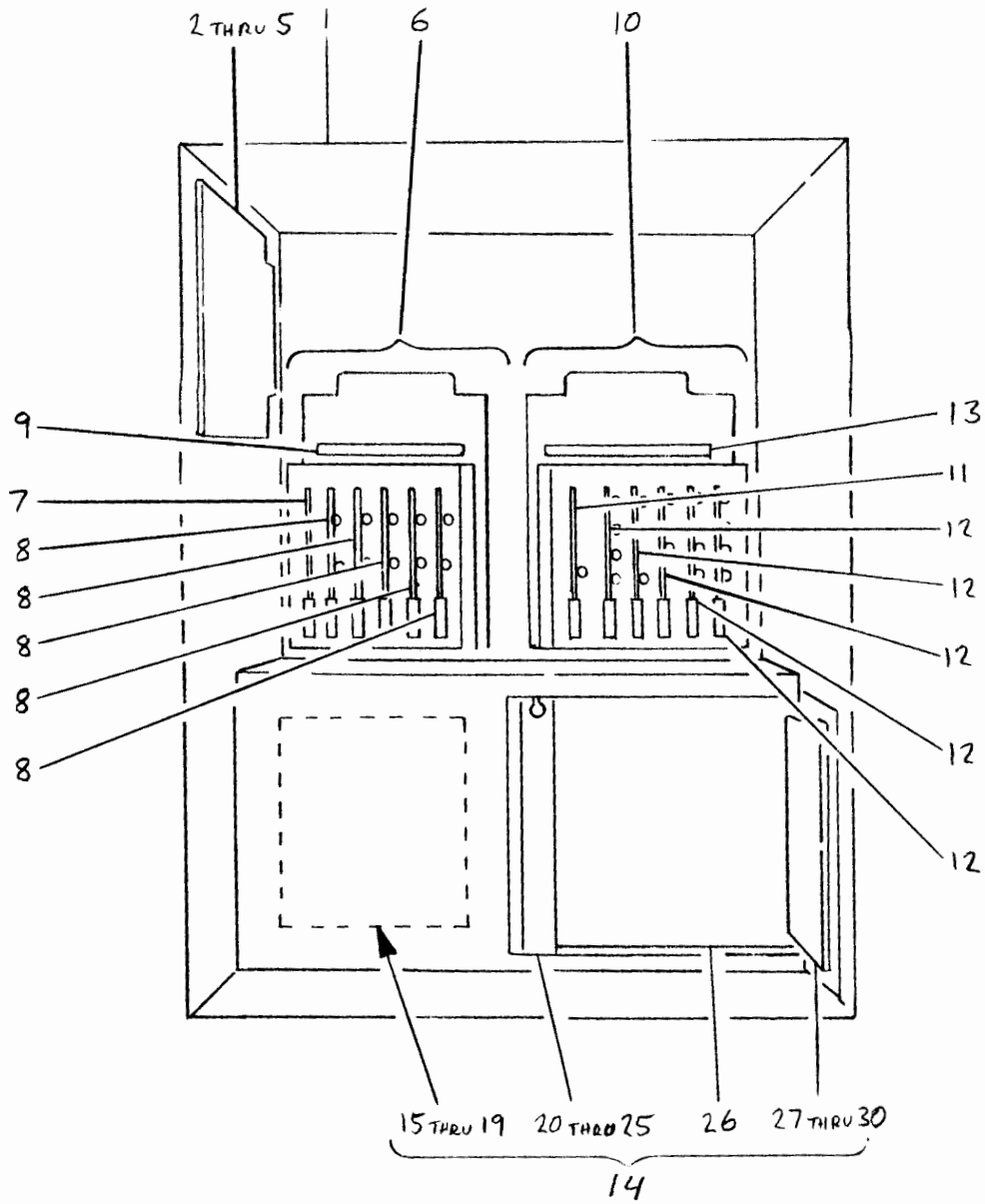

7970-A-36-1

Figure 11-3. Cabinet Assembly (Sheet 1 of 2)

TOP REAR ACCESS PANEL (07970-00390)

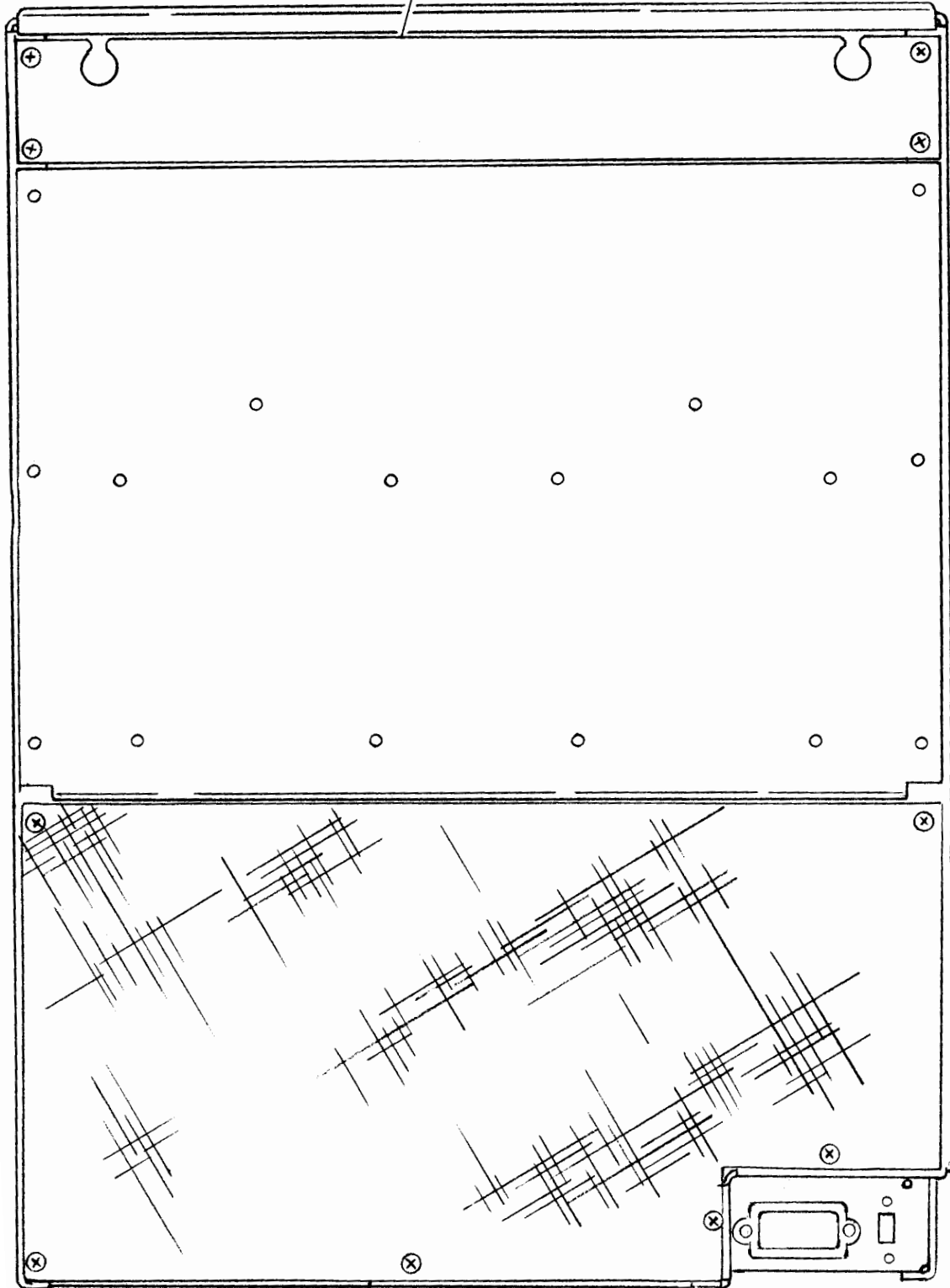

BOTTOM REAR ACCESS PANEL (07970-00080)

7970-A-36-2

Figure 11-3. Cabinet Assembly (Sheet 2 of 2)

FIG. & INDEX NO.	PART NUMBER	DESCRIPTION				UNITS PER ASSY
		1	2	3	4	
3-		CABINET ASSEMBLY				
-1	07970-60450	.	MAINFRAME,	Cabinet		1
-2	07970-60400	.	MOTION CONTROL PCB ASSEMBLY	(A16)		1
-3	2360-0195	.	SCREW	-		4
-4	2190-0085	.	WASHER	-		4
-5	3050-0227	.	WASHER	-		4
-6	Ref. Only	.	WRITE DATA ASSEMBLY,	10-20 ips (A17)		1
Ref.	07970-60230	.	WRITE INTERCONNECT SUBASSEMBLY			1
-7	07970-60240	.	WRITE CONTROL PCB SUBASSEMBLY	(A7A1)		1
-8	07970-60800	.	WRITE DATA PCB SUBASSEMBLY	10-20 ips (A17A2 thru A6)		1
-9	(Not Assigned)	.	WRITE PARITY PCB SUBASSEMBLY	(A17A7)		1
	(Not Assigned)	.	WRITE PARITY PCB SUBASSEMBLY	(A17A7)		1
	Ref. Only	.	WRITE DATA ASSEMBLY,	20-37-1/2 ips (A17)		1
	07970-60230	.	WRITE INTERCONNECT SUBASSEMBLY			1
	07970-60240	.	WRITE CONTROL PCB SUBASSEMBLY	(A17A1)		1
	07970-60810	.	WRITE DATA PCB SUBASSEMBLY,	20-37-1/2 ips (A17A2 thru A6)		1
	(Not Assigned)	.	WRITE PARITY PCB SUBASSEMBLY	(A17A7)		1
	(Not Assigned)	.	WRITE PARITY PCB SUBASSEMBLY	(A17A7)		1
-10	Ref. Only	.	READ DATA ASSEMBLY,	10-20 ips (A18)		1
Ref.	07970-60390	.	READ INTERCONNECT SUBASSEMBLY			1
-11	07970-60540	.	READ CONTROL PCB SUBASSEMBLY,	10-20 ips (A18A1)		1
-12	07970-60520	.	READ DATA PCB SUBASSEMBLY,	10-20 ips (A18A2 thru A6)		1
-13	(Not Assigned)	.	READ PARITY PCB SUBASSEMBLY	(A18A7)		1
	Ref. Only	.	READ DATA ASSEMBLY,	20-37-1/2 ips (A18)		1
	07970-60390	.	READ INTERCONNECT SUBASSEMBLY			1
	07970-60550	.	READ CONTROL PCB SUBASSEMBLY	20-37-1/2 ips (A18A1)		1
	07970-60530	.	READ DATA PCB SUBASSEMBLY,	20-37-1/2 ips (A18A2 thru A6)		1

FIG. & INDEX NO.	PART NUMBER	DESCRIPTION				UNITS PER ASSY
		1	2	3	4	
3-13	(Not Assigned)	.	.	READ PARITY PCB SUBASSEMBLY (A18A7)	1	
-14	Ref. Only	.		POWER SUPPLY ASSEMBLY (A19)	1	
-15	07970-60470	.	.	TRANSFORMER SUBASSEMBLY (A19A1)	1	
-16	2680-0129	.	.	SCREW -	3	
-17	2680-0099	.	.	SCREW -	7	
-18	2190-0034	.	.	WASHER -	10	
-19	3050-0002	.	.	WASHER -	10	
-20	07970-60440	.	.	POWER SUPPLY SUBASSEMBLY (A19A2)	1	
-21	2200-0141	.	.	SCREW -	6	
-22	2680-0101	.	.	SCREW -	2	
-23	2190-0004	.	.	WASHER -	6	
-24	2190-0034	.	.	WASHER -	2	
-25	3050-0002	.	.	WASHER -	2	
-26	07970-60110	.	.	POWER SUPPLY PCB SUBASSEMBLY (A19A2A1)	1	
-27	07970-60020	.	.	POWER REGULATOR PCB SUB- ASSEMBLY (A19A3)	1	
-28	2360-0195	.	.	SCREW -	2	
-29	2190-0085	.	.	WASHER -	2	
-30	3050-0227	.	.	WASHER -	2	

TEMPORARY CHANGE PAGE

Product

Date of Change:

MODEL: 7970A Magnetic Tape Unit
SERIAL PREFIX XXXXXXXX: 1016A

3 December 1970

Literature

TITLE: Operating and Service Manual
DOCUMENT NO: 07970-90620
ISSUE/DATE: PRELIMINARY/July 1970

This temporary change page ^{adds} ~~replaces~~ information ^{to} ~~on~~ page 11-17 as follows:

Add:

Figure 11-4. 13190-60010 Control and Status Cable

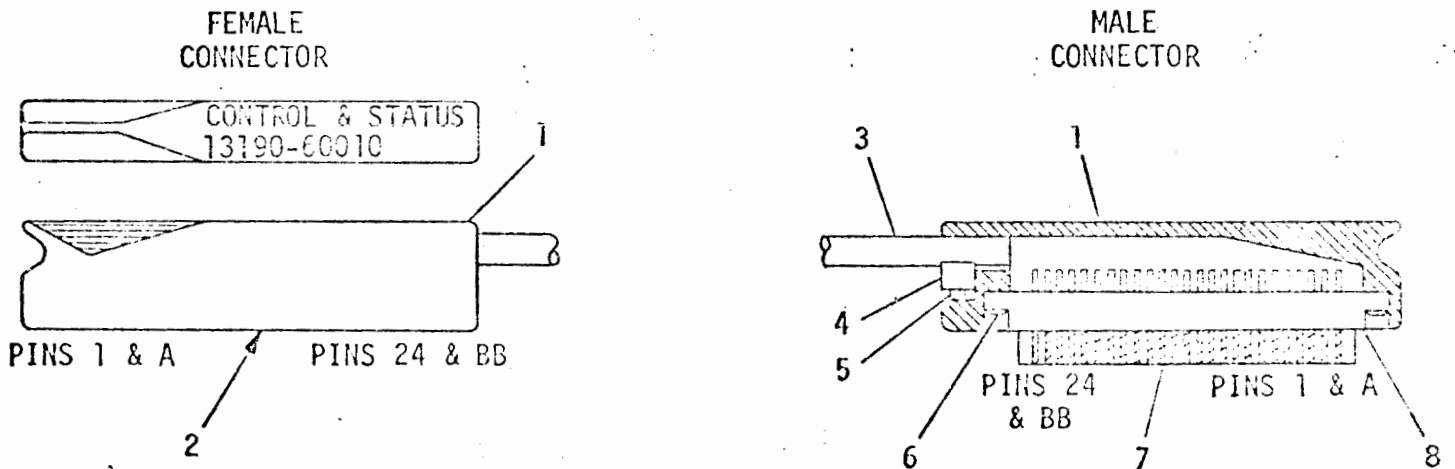

Place this temporary change page immediately preceding affected page.

TEMPORARY CHANGE PAGE

Product

MODEL: 7970A Magnetic Tape Unit
SERIAL PREFIX ~~XXXXXXXX~~: 1016A

Date of Change:

3 December 1970

Literature

TITLE: Operating and Service Manual
DOCUMENT NO: 07970-90620
ISSUE/DATE: PRELIMINARY/July 1970

This temporary change page ~~replaces~~ ^{adds} information ~~on~~ ^{to} page 11-18 as follows:

Add: Parts List for 13190-60010 Control and Status Cable.

FIG & INDEX NO.	PART NUMBER	DESCRIPTION				UNITS PER ASSY
		1	2	3	4	
REF	13190A	MULTI-UNIT CABLE ASSEMBLY				REF
4-	13190-60010	.	.	CONTROL & STATUS CABLE		1
-1	13190-40001	.	.	HOLDER		2
-2	1251-1400	.	.	KEY, PC Connector*		1
-3	8120-0957	.	.	CABLE - Unshielded (12-1/2 ft.)		1
-4	02116-4004	.	.	CLAMP, Cable		2
-5	3030-0143	.	.	SETSCREW		2
-6	0624-0026	.	.	TAP SCREW		4
-7	02116-8176	.	.	PC BOARD, Cable		1
-8	1251-0335	.	.	CONNECTOR		2

*Polarizing key is located between pins 5 and 6, Female Connector.

TEMPORARY CHANGE PAGE

Product

MODEL: 7970A Magnetic Tape Unit
SERIAL PREFIX ~~XXXXXXXXXX~~ 1016A

Date of Change:

3 December 1970

Literature

TITLE: Operating and Service Manual
DOCUMENT NO: 07970-90620
ISSUE/DATE: PRELIMINARY/July 1970

This temporary change page ~~replaces~~ ^{adds} information ~~on~~ ^{to} page 11-19 as follows:

Add:

Figure 11-5. 13190-60020 Read Cable

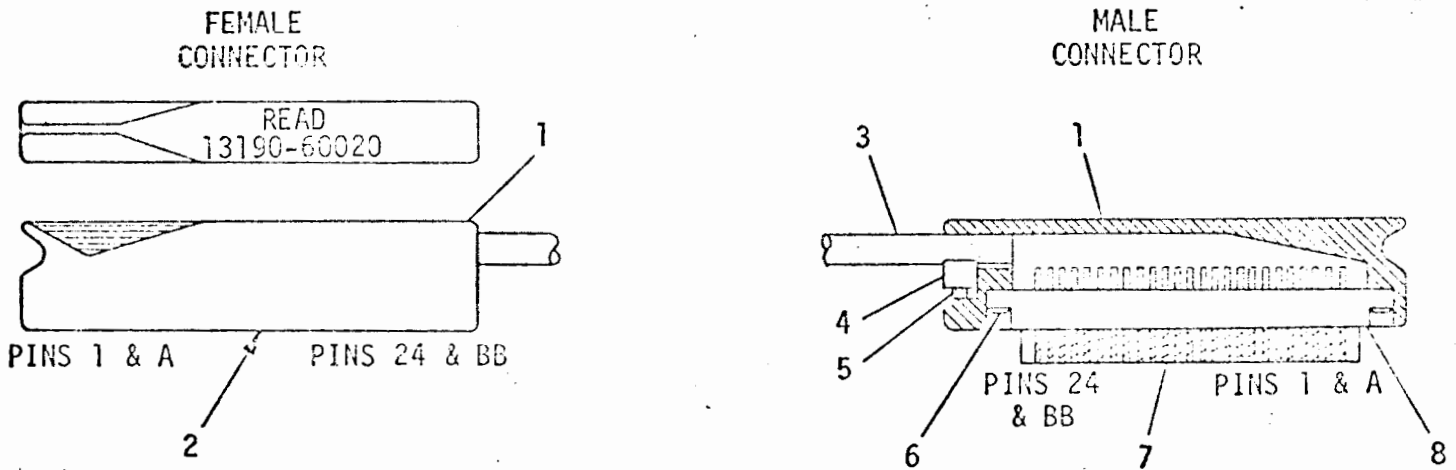

Place this temporary change page immediately preceding affected page.

TEMPORARY CHANGE PAGE

Product

Date of Change:

MODEL: 7970A Magnetic Tape Unit
SERIAL PREFIX ~~XXXXXXX~~ SERIAL: 1016A

3 December 1970

Literature

TITLE: Operating and Service Manual
DOCUMENT NO: 07970-90620
ISSUE/DATE: PRELIMINARY/July 1970

This temporary change page ~~xxxxxxx~~ adds information ~~on~~ to page 11-20 as follows:

Add: Parts List for Figure 11-5, 13190-60020 Read Cable.

FIG & INDEX NO.	PART NUMBER	DESCRIPTION				UNITS PER ASSY
		1	2	3	4	
REF	13190A	MULTI-UNIT CABLE ASSEMBLY				REF
5-	13190-60020	1
-1	13190-40002	2
-2	1251-1400*	1
-3	8120-1522	1
-4	02116-4003	2
-5	3030-0143	2
-6	0624-0026	4
-7	02116-8176	1
-8	1251-0335	2

*Polarizing key is located between pins 17 and 18, Female Connector.

Place this temporary change page immediately preceding affected page.

TEMPORARY CHANGE PAGE

Product

MODEL: 7970A Magnetic Tape Unit
SERIAL PREFIX ~~XXXXXXXX~~ 1016A

Date of Change:

3 December 1970

Literature

TITLE: Operating and Service Manual
DOCUMENT NO: 07970-90620
ISSUE/DATE: PRELIMINARY/July 1970

This temporary change page ~~replaces~~ adds to ~~the~~ information on page 11-21 as follows:

Add:

Figure 11-6. 13190-60030 Write Cable

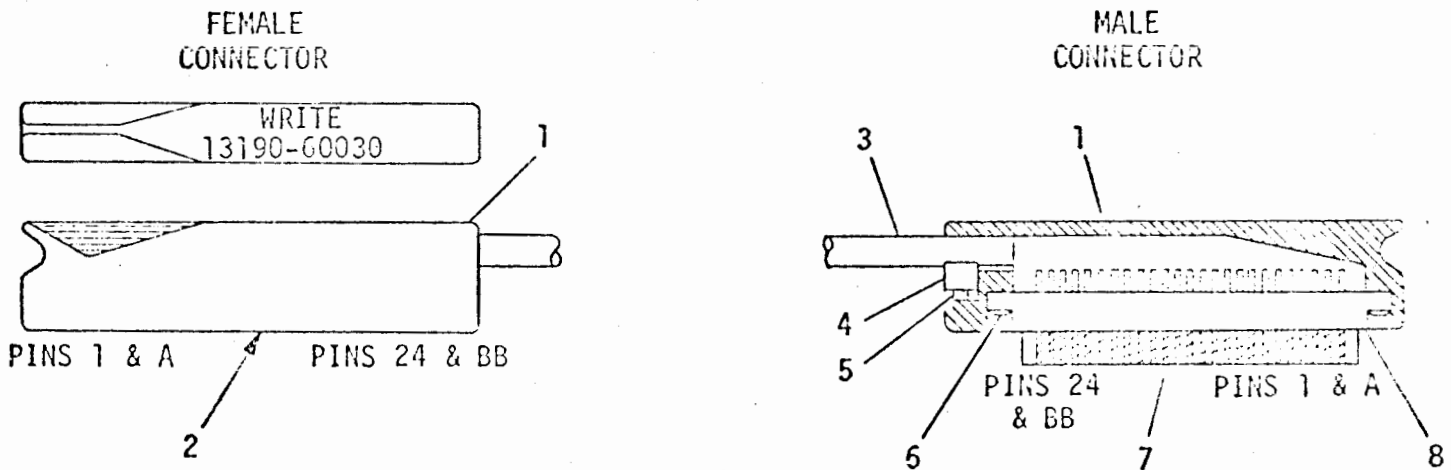

Place this temporary change page immediately preceding affected page.



TEMPORARY CHANGE PAGE

Product

Date of Change:

MODEL: 7970A Magnetic Tape Unit
SERIAL PREFIX ~~XXXXXXX~~: 1016A

3 December 1970

Literature

TITLE: Operating and Service Manual
DOCUMENT NO: 07970-90620
ISSUE/DATE: PRELIMINARY/July 1970

This temporary change page ~~replaces~~ adds information on page 11-22 as follows:

Add: Parts List for Figure 11-6, 13190-60030 Write Cable

FIG & INDEX NO.	PART NUMBER	DESCRIPTION				UNITS PER ASSY
		1	2	3	4	
REF	13190A	MULTI-UNIT CABLE ASSEMBLY				REF
6-	13190-60030	. WRITE CABLE				1
-1	13190-40003	. . HOLDER, Write				2
-2	1251-1400	. . KEY, PC Connector*				1
-3	8120-1522	. . CABLE, Unshielded (12-1/2 ft.)				1
-4	02116-4003	. . CLAMP, Cable				2
-5	3030-0143	. . SETSCREW				2
-6	0624-0026	. . TAP SCREW				4
-7	02116-8176	. . PC BOARD, Cable				1
-8	1251-0335	. . CONNECTOR, PC, 48 CONT				2

*Polarizing key is located between pins 18 and 19, Female Connector.

Place this temporary change page immediately preceding affected page.

SECTION XII

DIAGRAMS

(Text to be supplied)

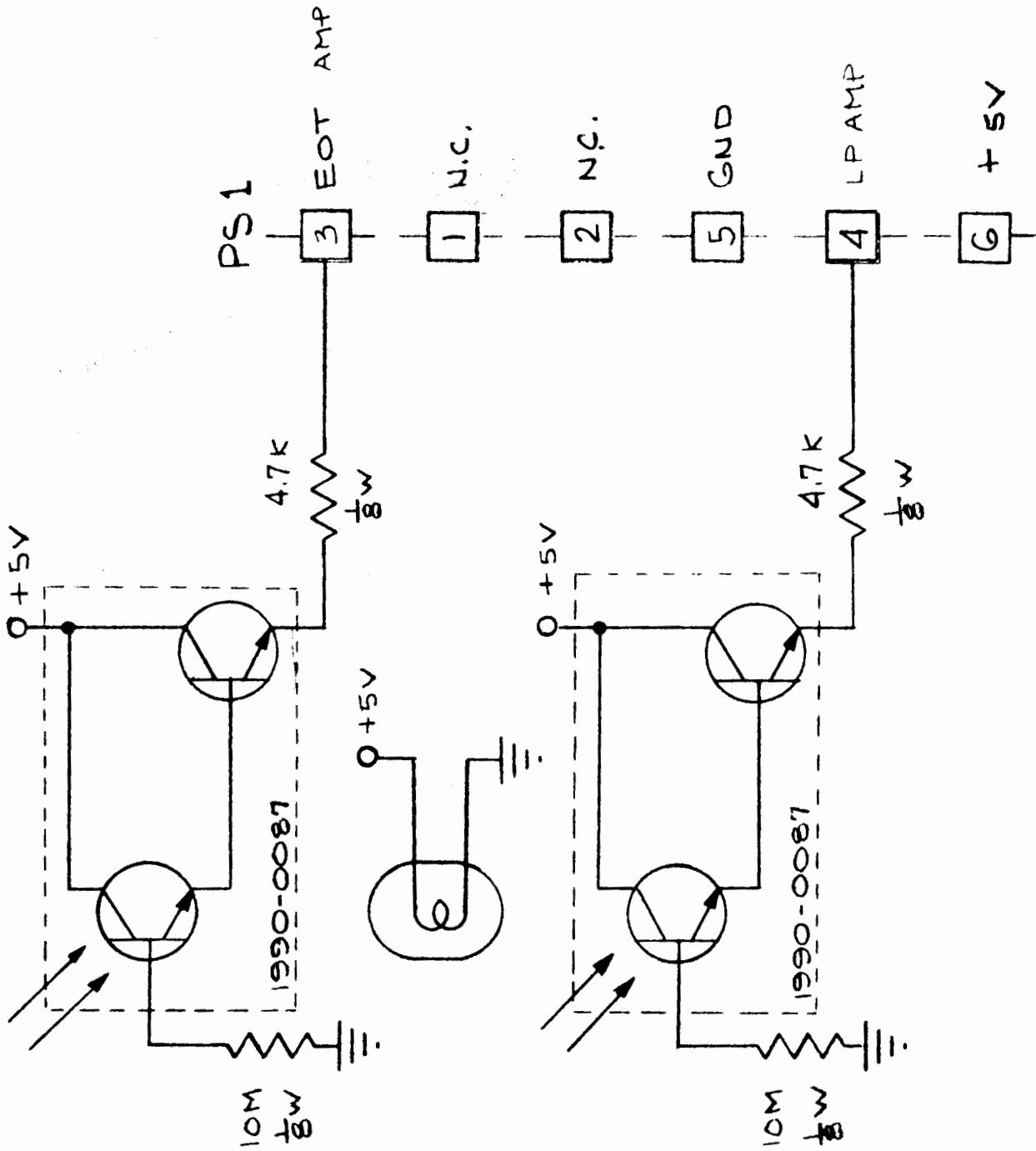

EDGE

7970-A-37

Figure 12-1. Photosense Head Assembly (A2), Schematic

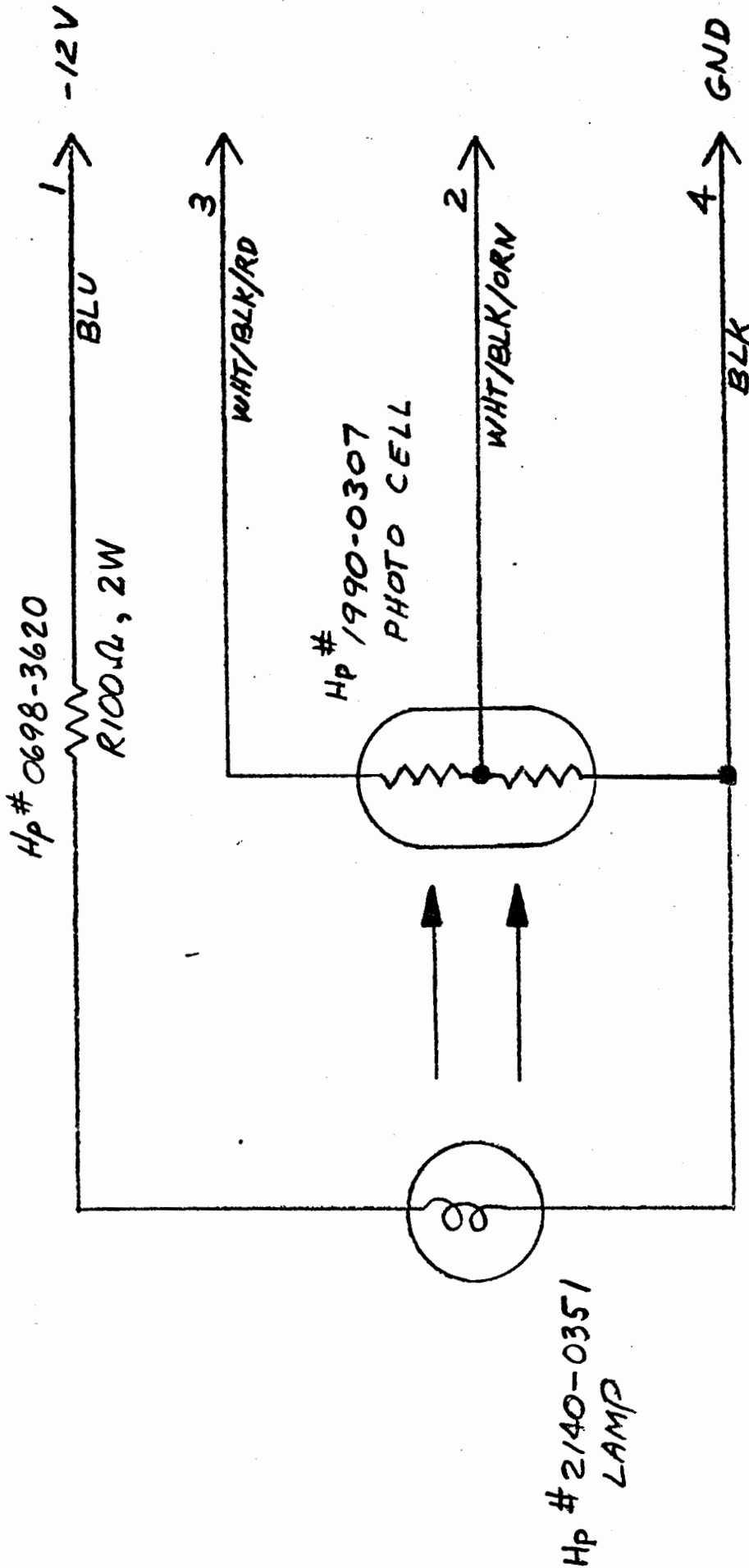

Figure 12-2. Tension Arm (A3/A4) Schematic

TEMPORARY CHANGE PAGE

Product

MODEL: 7970A Magnetic Tape Unit
SERIAL PREFIX ~~XXXXXXXX~~: 1030A

Date of Change:

29 July 1970

Literature

TITLE: Operating and Service Manual
DOCUMENT NO: 07970-90620
ISSUE/DATE: Preliminary/July 1970

This temporary change page replaces information on page 12-3 as follows:

(SEE OTHER SIDE)

Place this temporary change page immediately preceding affected page.

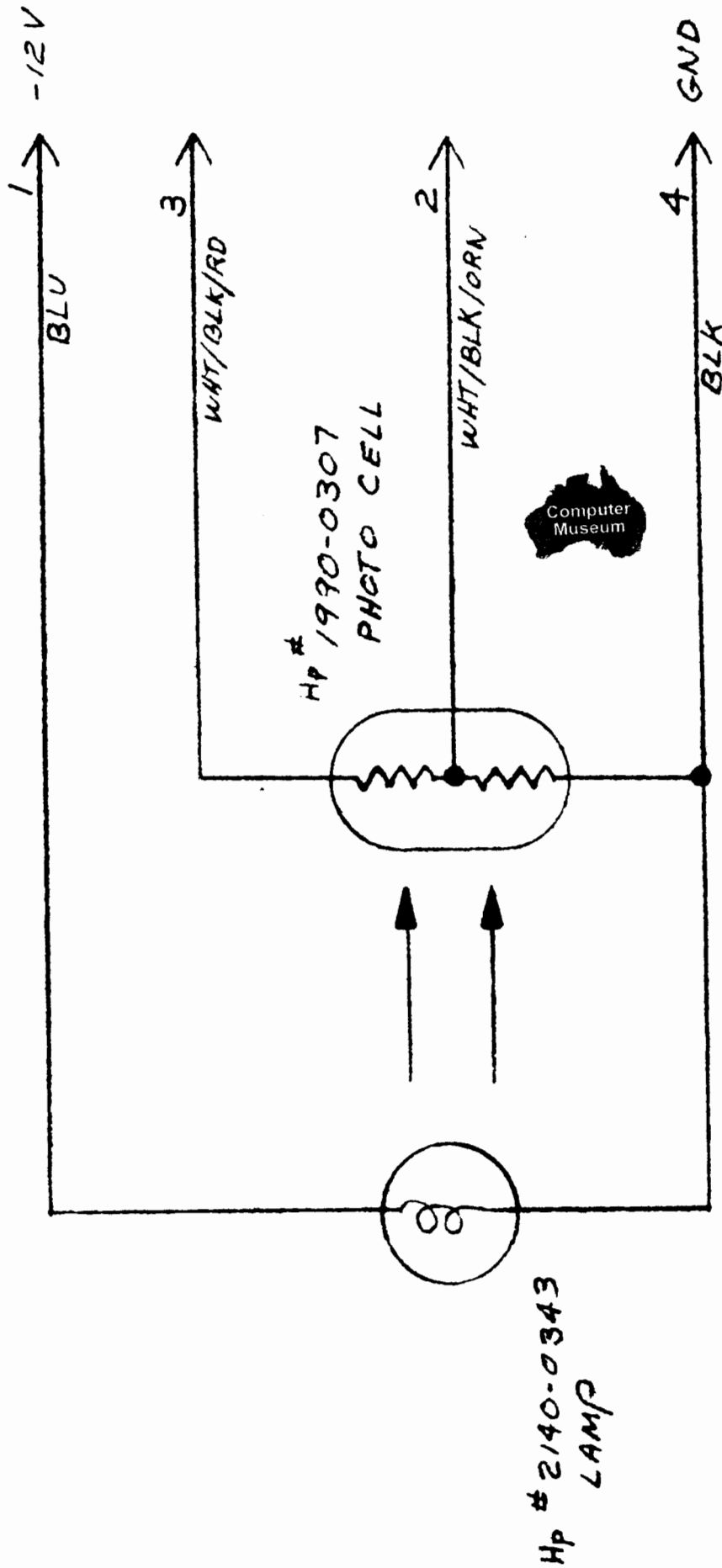

7970-A-38

Figure 12-2. Tension Arm (A3/A4) Schematic

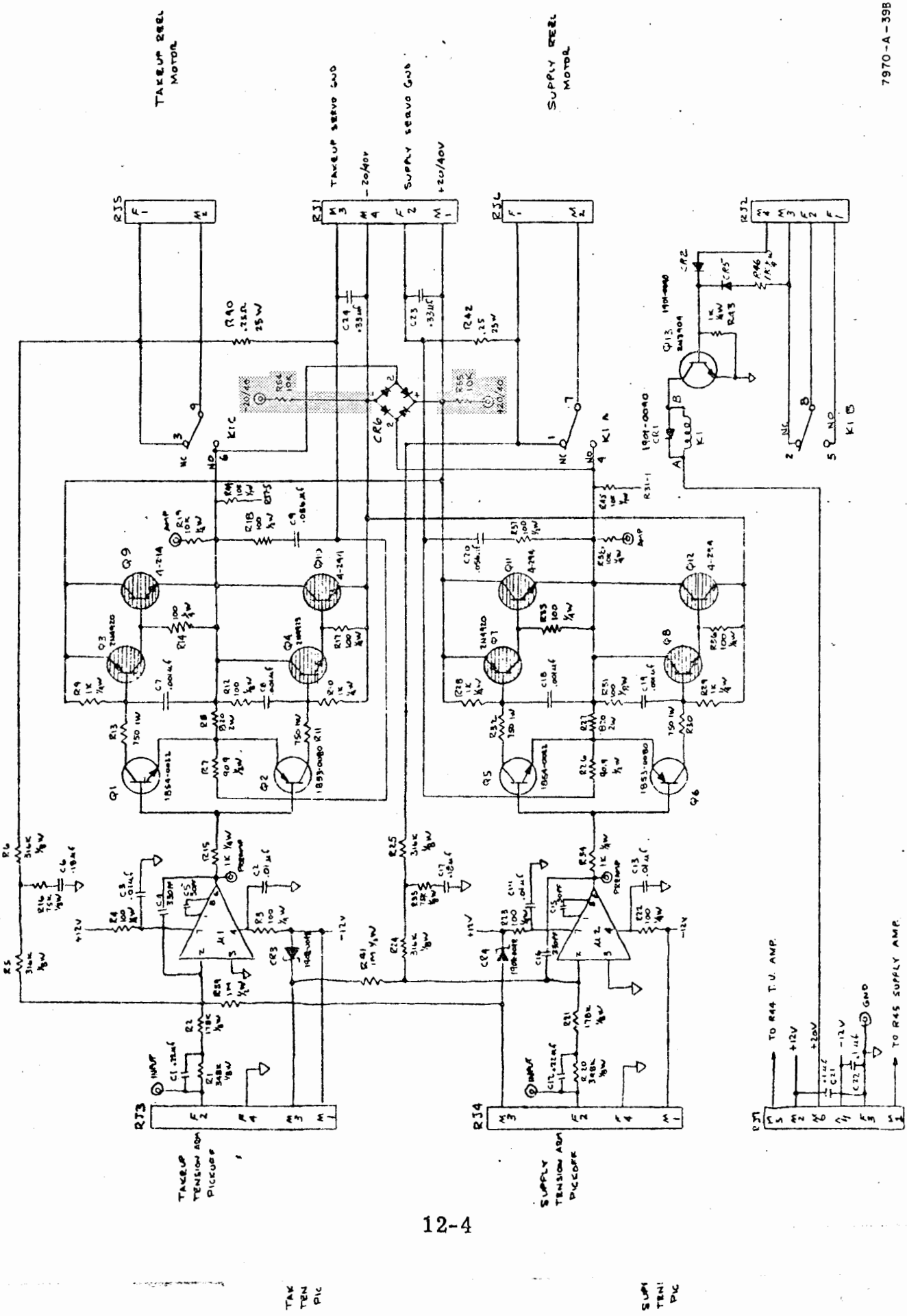

12-4

TAK
TEN
PIC

SUP
TEN
PIC

12-4

Figure 12-3. Reel Servo (A7) Schematic (Series 1038A)

Figure 12-3. Reel Servo (A7) Schematic

7970-A-39

7970-A-39B

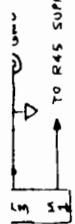

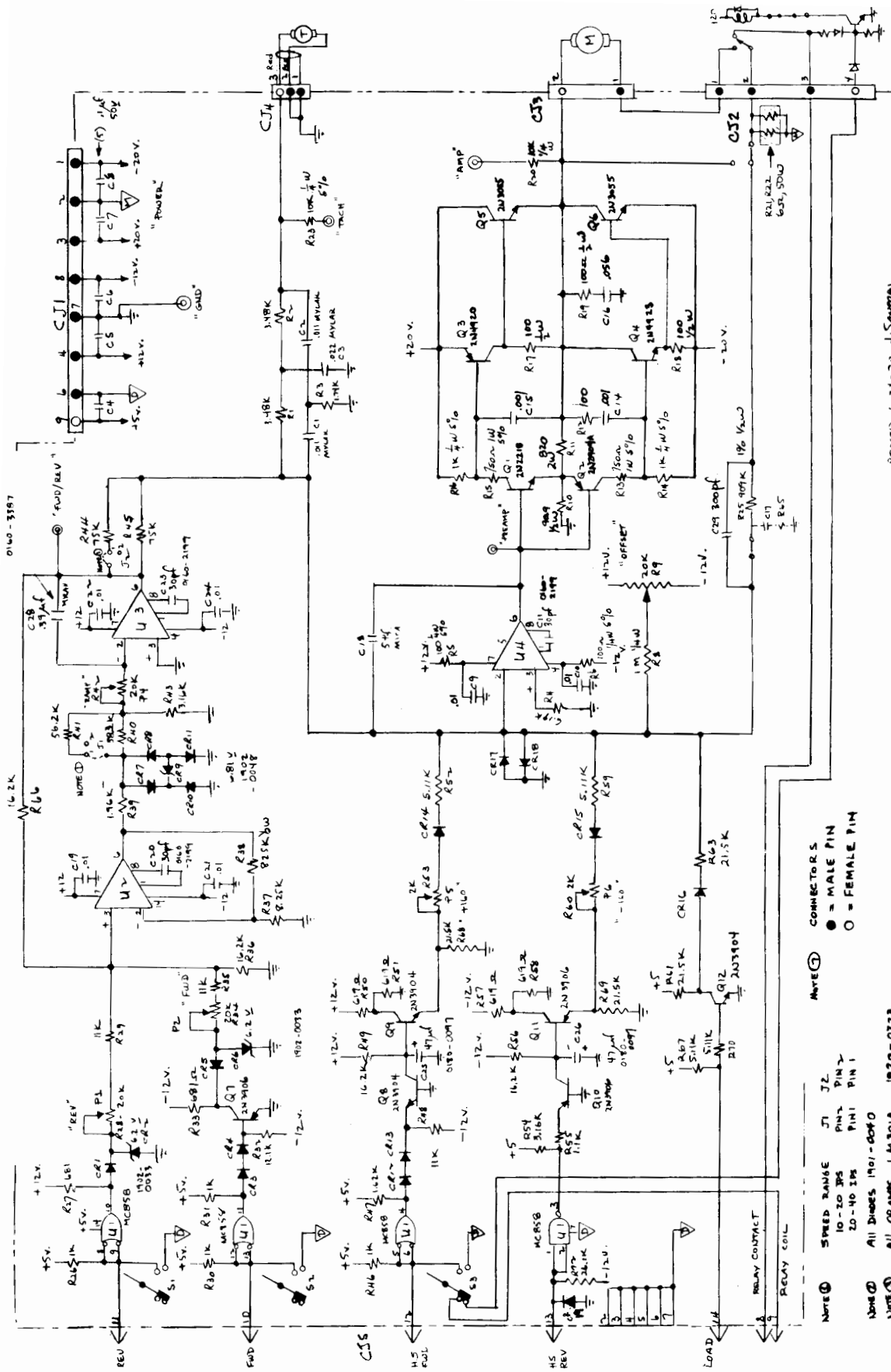

DESIGNED 6-21-70 J. SAUNDERS
 REVISED 6-10-70 J. SAUNDERS
 REVISED 1-19-76 NPD

- NOTE 1 SPEED RANGE J1 J2
 10-20 IPS PIN 2
 20-40 IPS PIN 1
- NOTE 2 ALL DIODES 1N91-0040
- NOTE 3 ALL OP AMPS LM101A 1020-0223
- NOTE 4 DIGITAL (45VMT) GND RETURN
- NOTE 5 ANALOG (±12VMT) GND RETURN
- NOTE 6 R9, R28, R34 2100-1972 (BOURNS 300FP-1-205 20K)
 R4, R11, R12 2100-1762
 R53, R60 2100-2851 (BOURNS 300FP-1-202 2K)
 NOTE 7 ALL RESISTORS 1% 1/8W 1/4W UNLESS OTHERWISE SPEC.
- NOTE 8 CONNECTORS
 ● = MALE PIN
 ○ = FEMALE PIN
- NOTE 9 MOTOR RETURN (±10V GND RETURN)

Figure 12-4. Capstan Servo (A9) Schematic

Revise Figure 12-5, Write Enable Assembly (A10) Schematic as indicated:

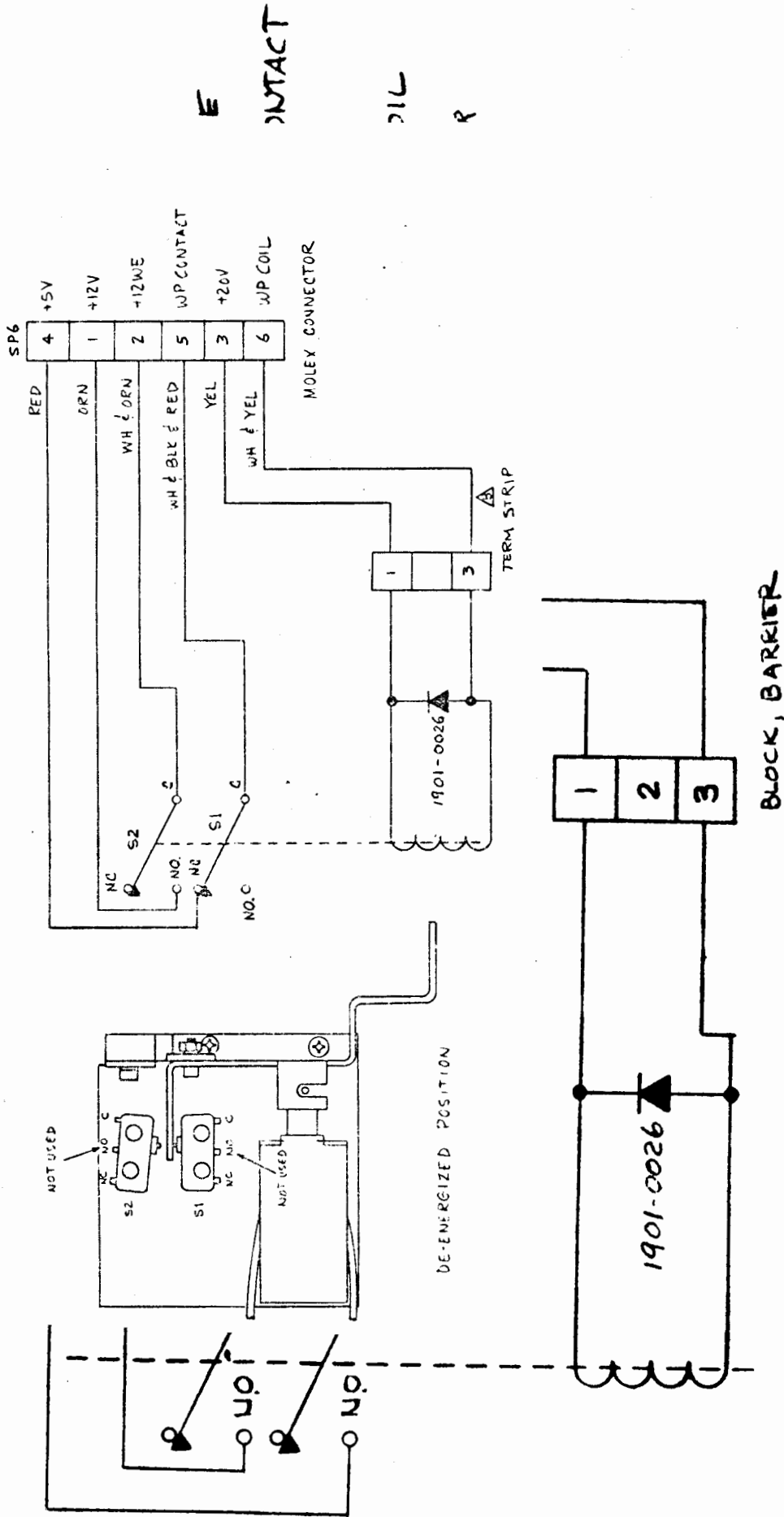

Figure 12-5. Write Enable Assembly (A10) Schematic

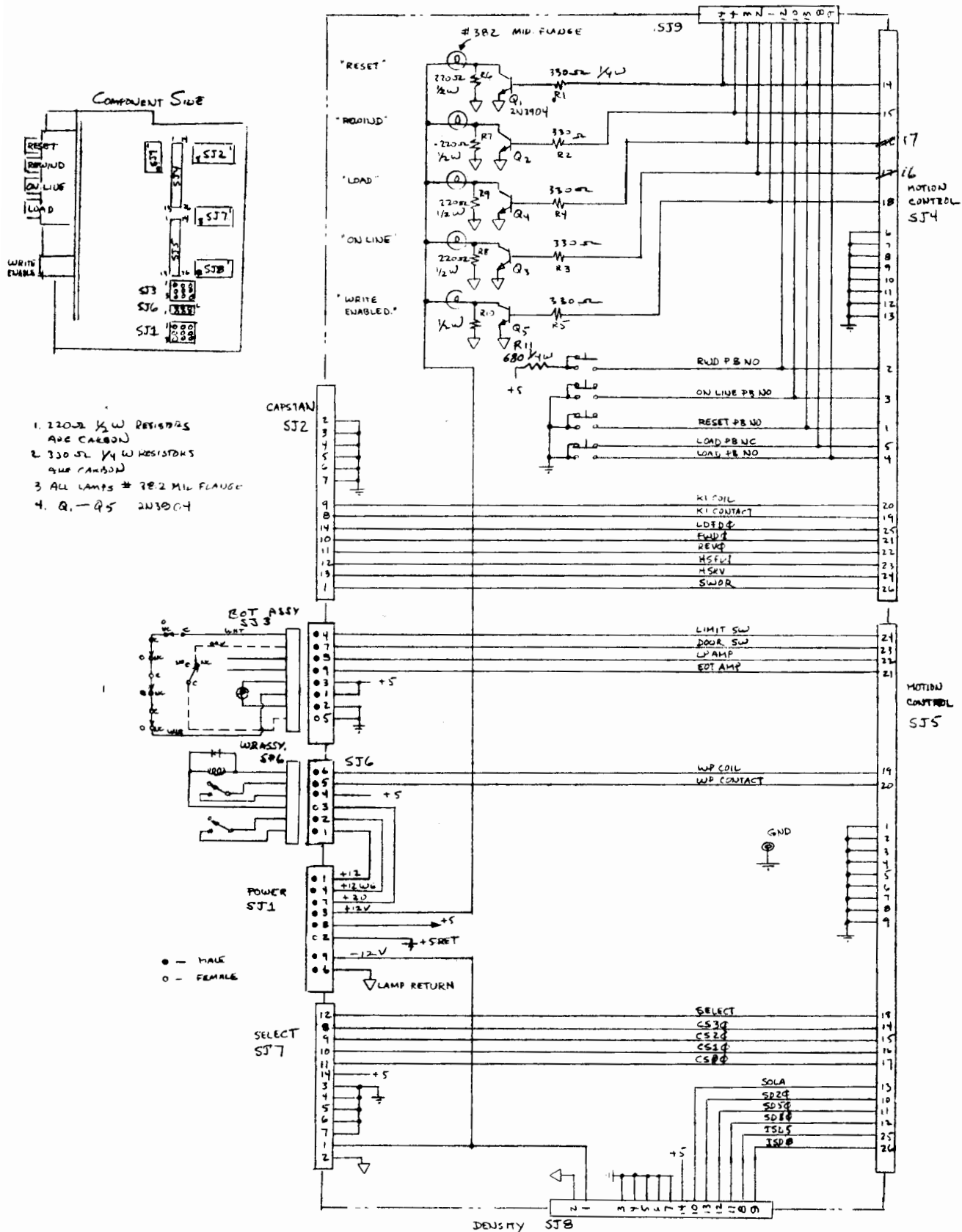

Figure 12-6. Control Switch (A11A1) Schematic

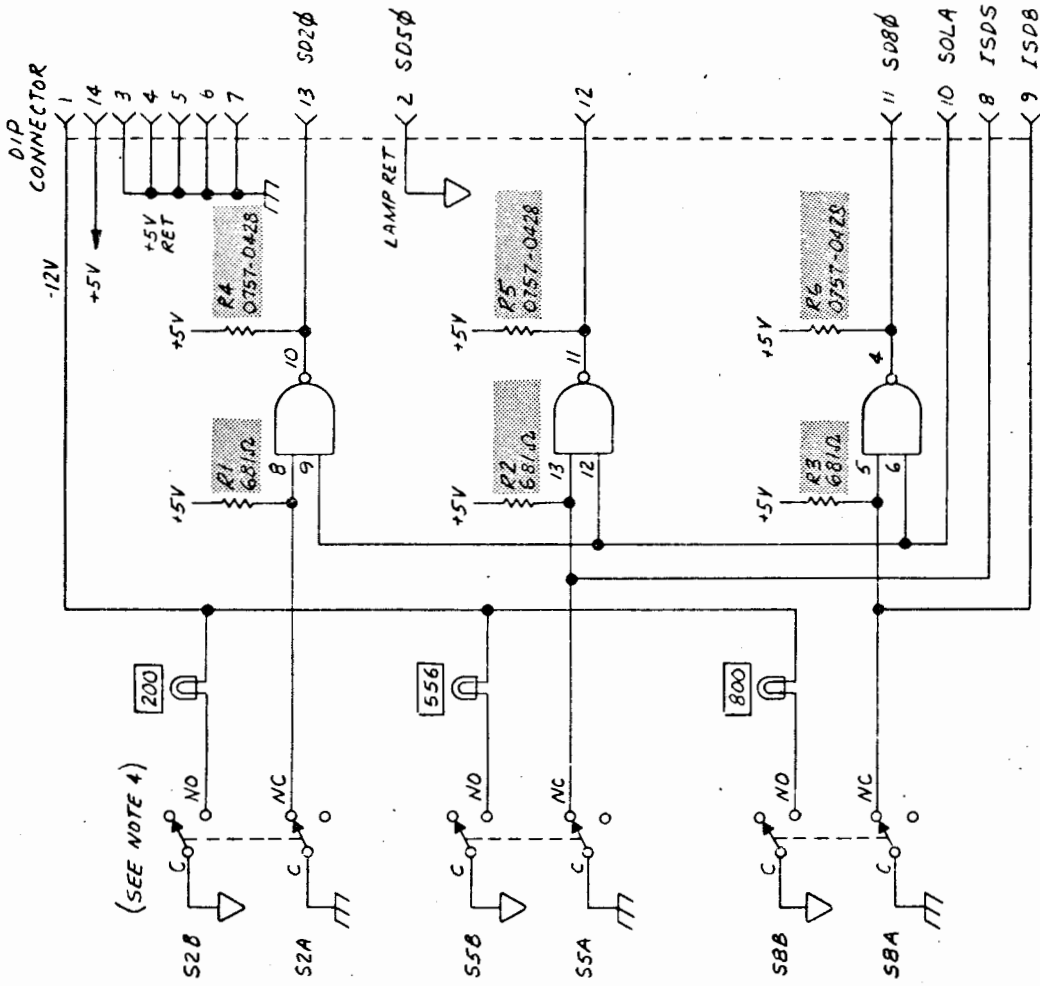
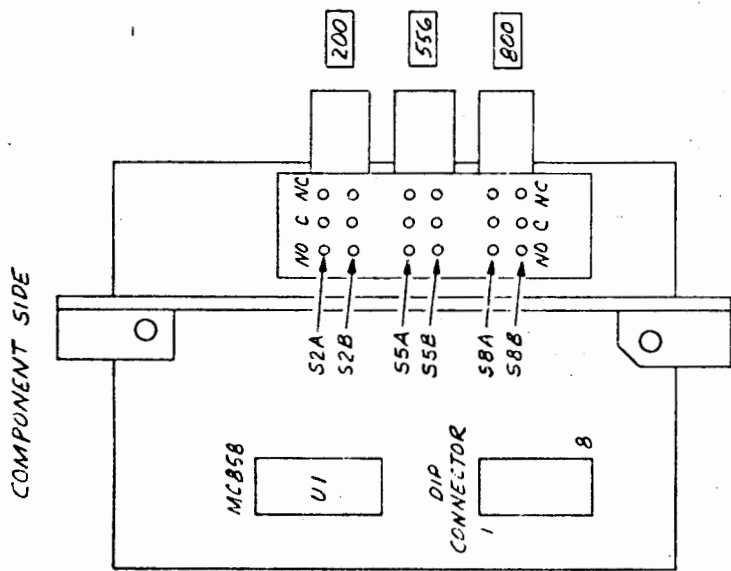
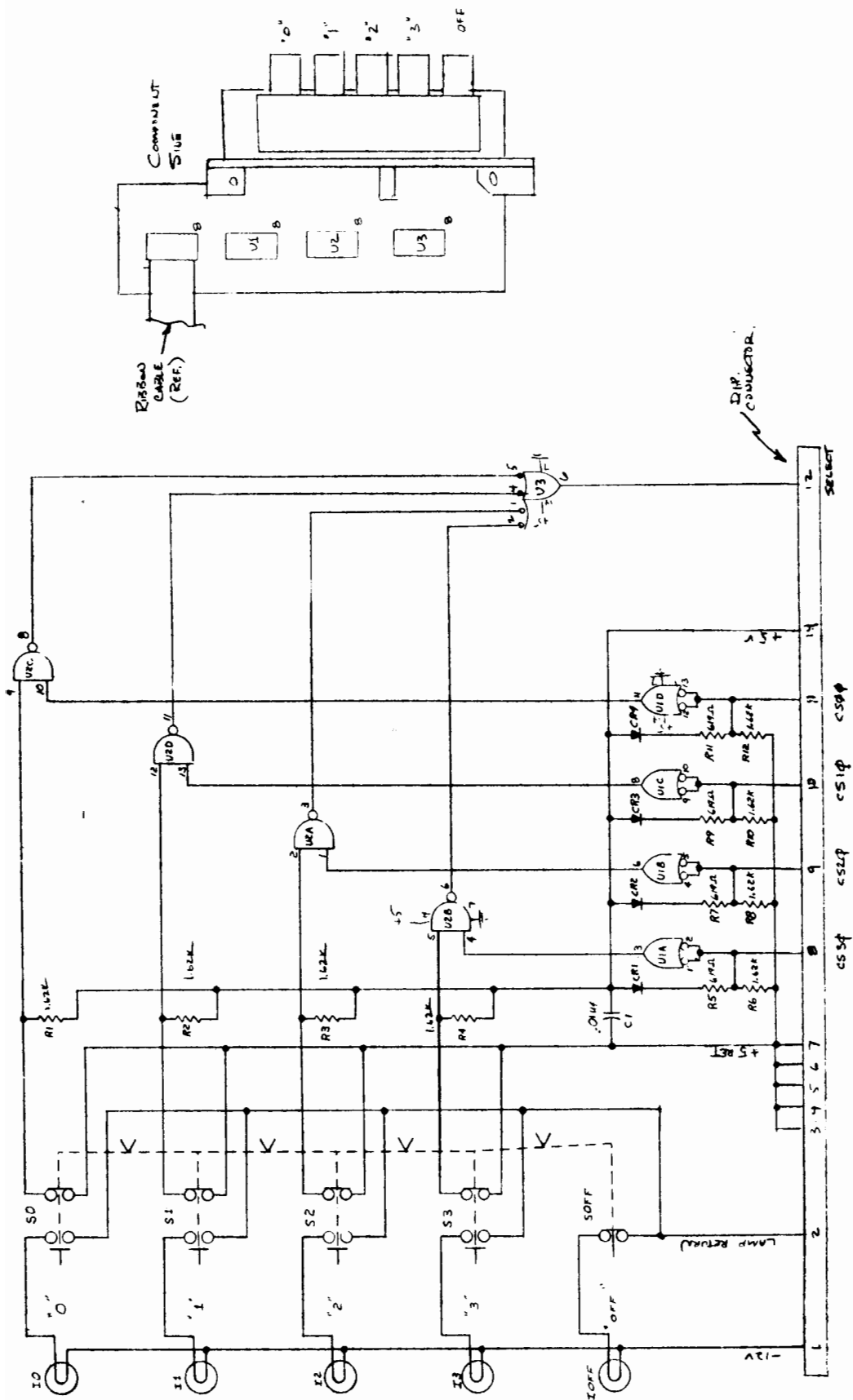

Figure 12-7. Density Select (A12A1)

Figure 12-7. Density Select (A12A1)



- NOTES:
1. ALL RESISTORS ARE 1/8W M.F.
 2. IC = MC858P, 1820-0256
 3. LAMPS ARE #392 MID. FLANGE
 4. SWITCHES ARE MECHANICALLY INTERLOCKED TO SELECT ONLY ONE SWITCH AT A TIME. EACH SWITCH IS 2-POLE DOUBLE THROW.



NOTE: SWITCHES ARE MECHANICALLY INTERLOCKED TO SELECT ONLY ONE SWITCH AT A TIME.

- 1. ALL RESISTORS 1/8 W M.F.
- 2. ALL DODGES 1901-0040
- 3. LAMPS - #182 MD. FLANGE.
- 4. U1 5U7482N
- U2 5U7482N
- U3 5U7482N

Figure 12-8. Unit Select (A13A1) Schematic

2. Change PCB Series Number from 101

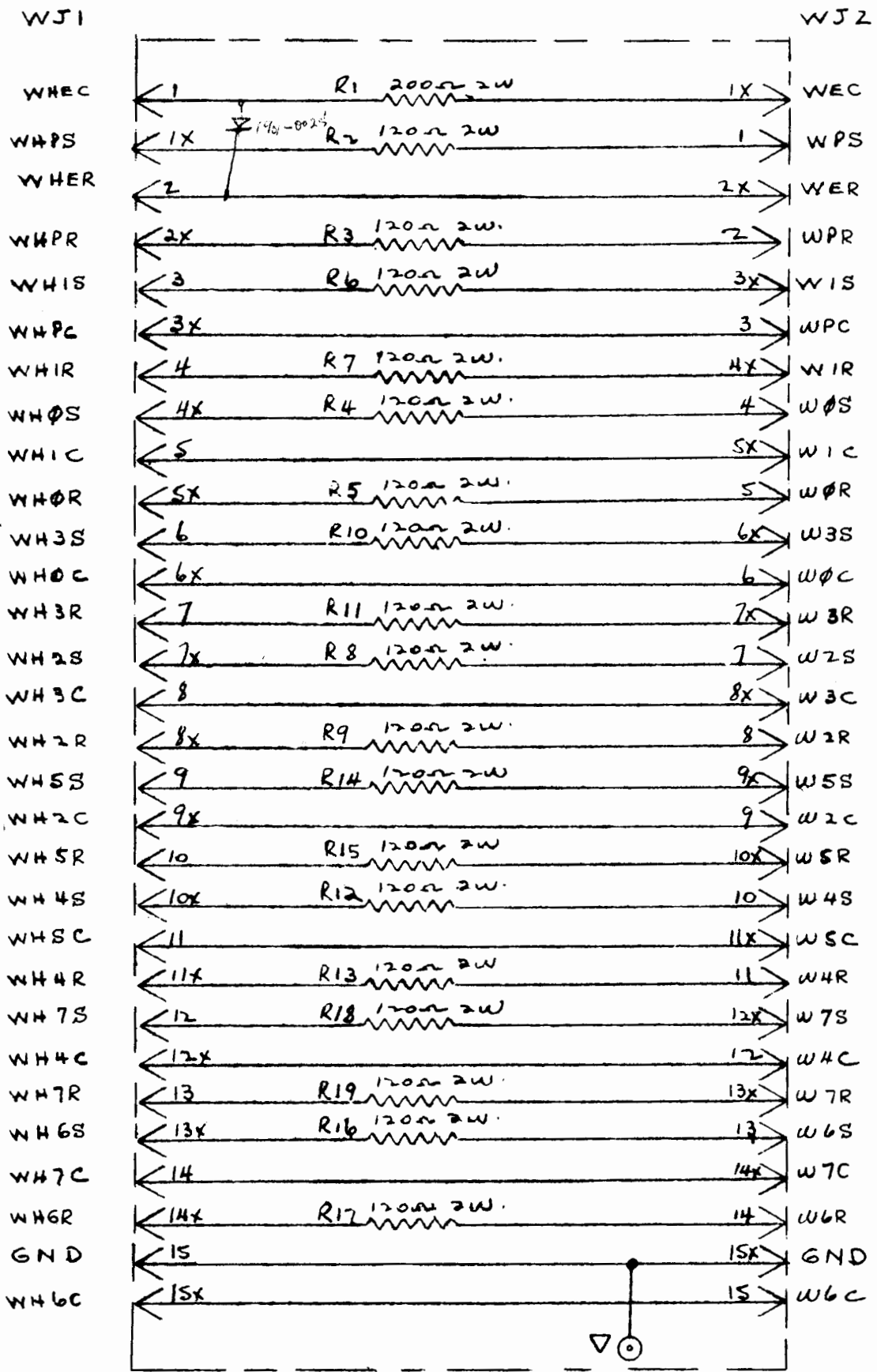

7970-A-45

Figure 12-9. Write Head Interconnect (A14) Schematic

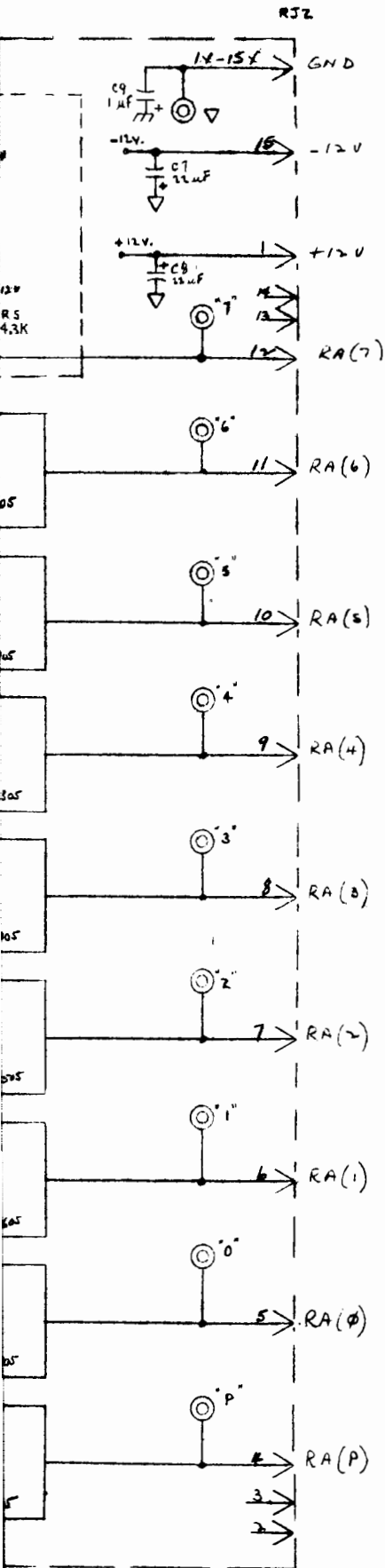

REVISION: 2-13-70 HFD

11 TEST POINTS ADDED
 R5 CHANGED FROM 10K TO 8.2K
 R2 CHANGED FROM HORIZONTAL TO VERTICAL TYPE
 24P4 P.C. CONNECTOR DELETED
 P.C. SIGNAL CONNECTOR 07970-50440 DELETED
 ORDER OF CHANNELS REVERSED

REVISION: 3-16-70 HFD

1 GND TEST POINT DELETED

REVISION: 4-20-70 HFD

C6 = .002 uF 10% CAPACITOR INSTEAD OF 12 uF
 RETURNED TO GND INSTEAD OF PIN 6

REVISION: 4-21-70 HFD

C6 = .002 uF 10% CAPACITOR RETURNED TO -12V, INSTEAD OF TO GND



SPEED (ups)	C.3*	DRAWING NO.
10-20	680uF	07970-60500
20-37-1/2	330uF	07970-60510

7970-F-46

Figure 12-10. Read Head Preamplifier (A15) Schematic

R31

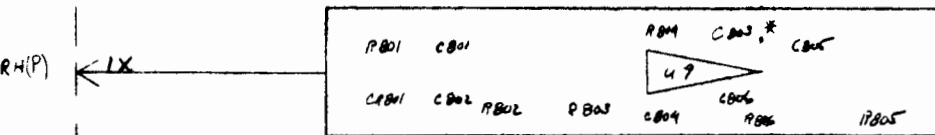
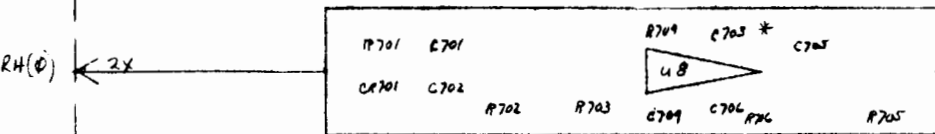
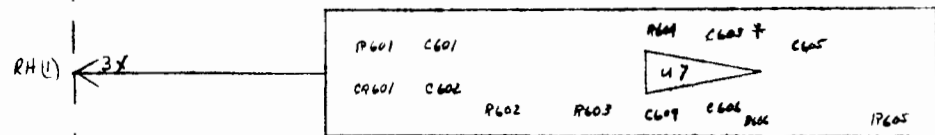
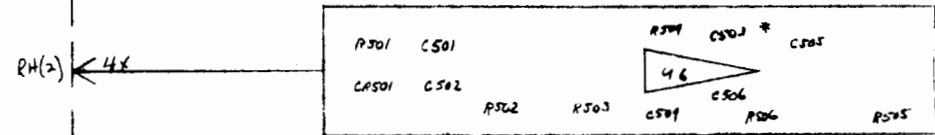
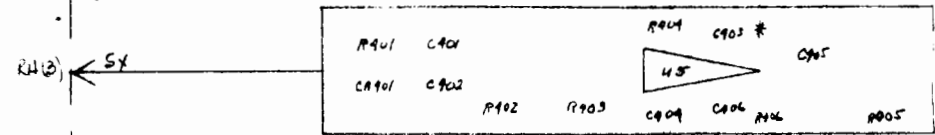
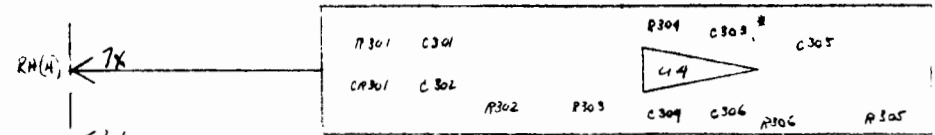
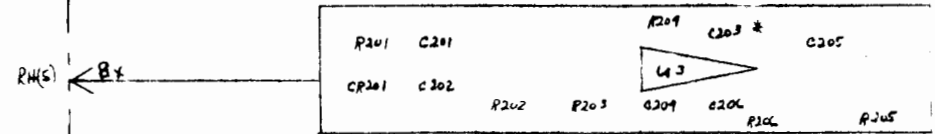
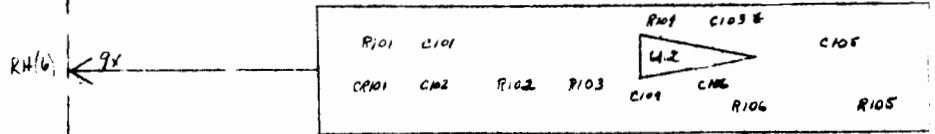
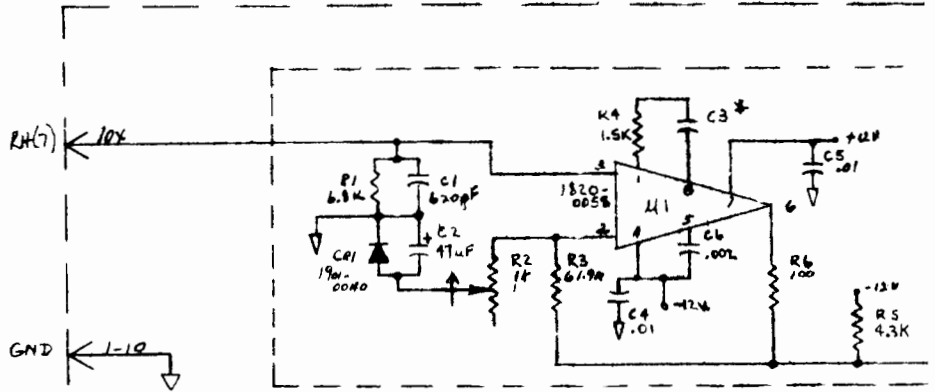

RH(7) ← 10x
 GND ← I-10
 RH(6) ← 9x
 RH(5) ← 8x
 RH(4) ← 7x
 ← 6x
 RH(3) ← 5x
 RH(2) ← 4x
 RH(1) ← 3x
 RH(0) ← 2x
 RH(P) ← 1x

TEMPORARY CHANGE PAGE

Product

MODEL: 7970A Magnetic Tape Unit
SERIAL PREFIX ~~XXXXXX~~: 1016A

Date of Change:

28 July 1970

Literature

TITLE: Operating and Service Manual
DOCUMENT NO: 07970-90620
ISSUE/DATE: Preliminary/July 1970

This temporary change page replaces information on page 12-12 as follows:

FROM:

TO:

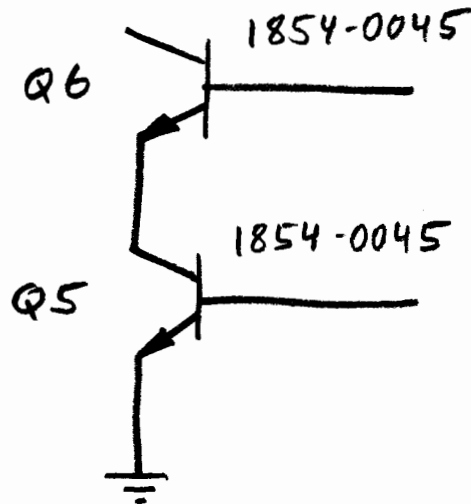
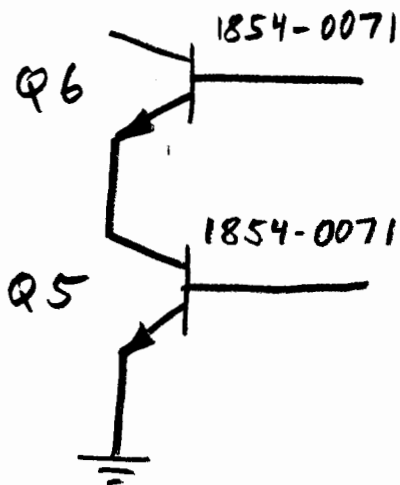

Place this temporary change page immediately preceding affected page.

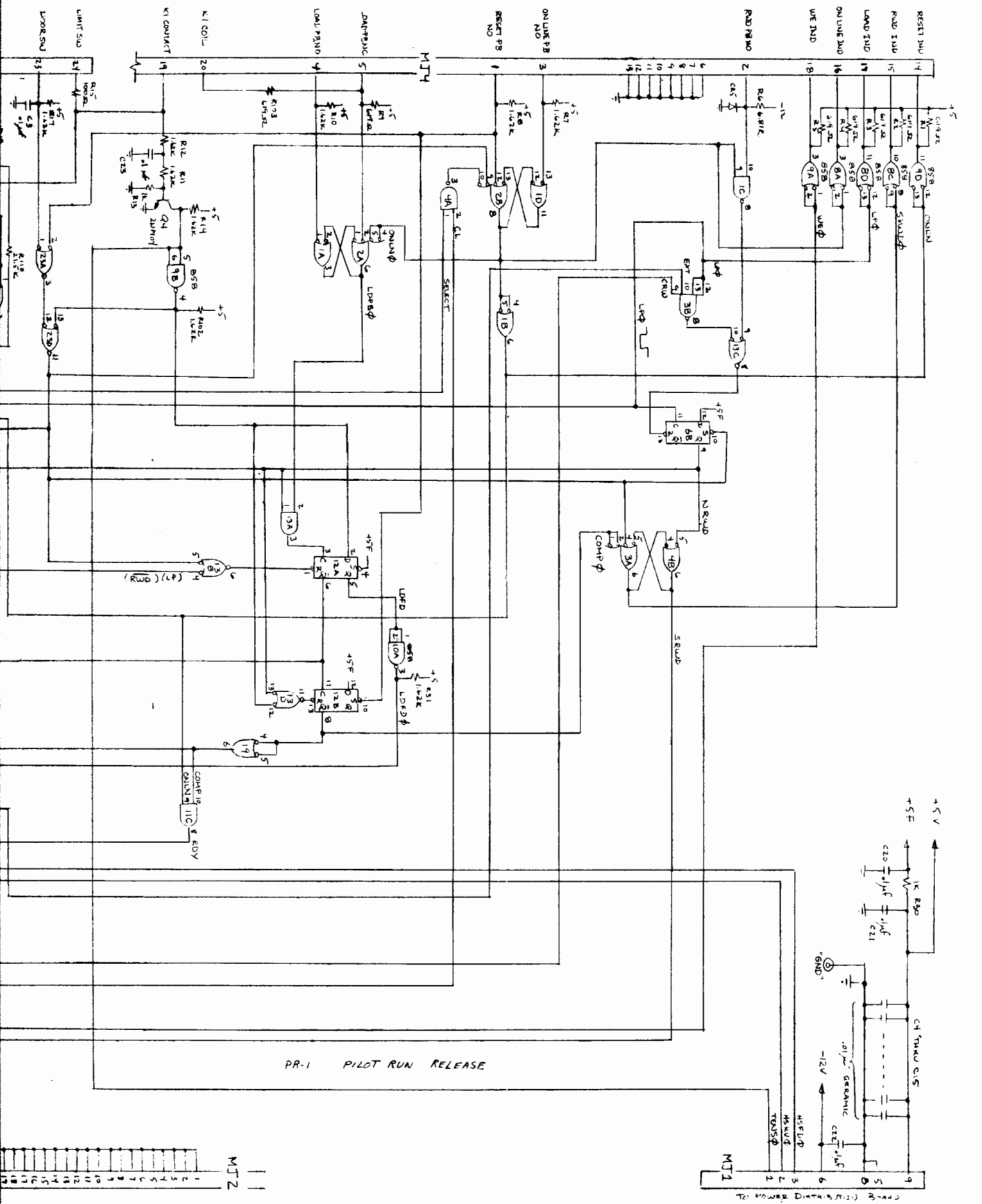
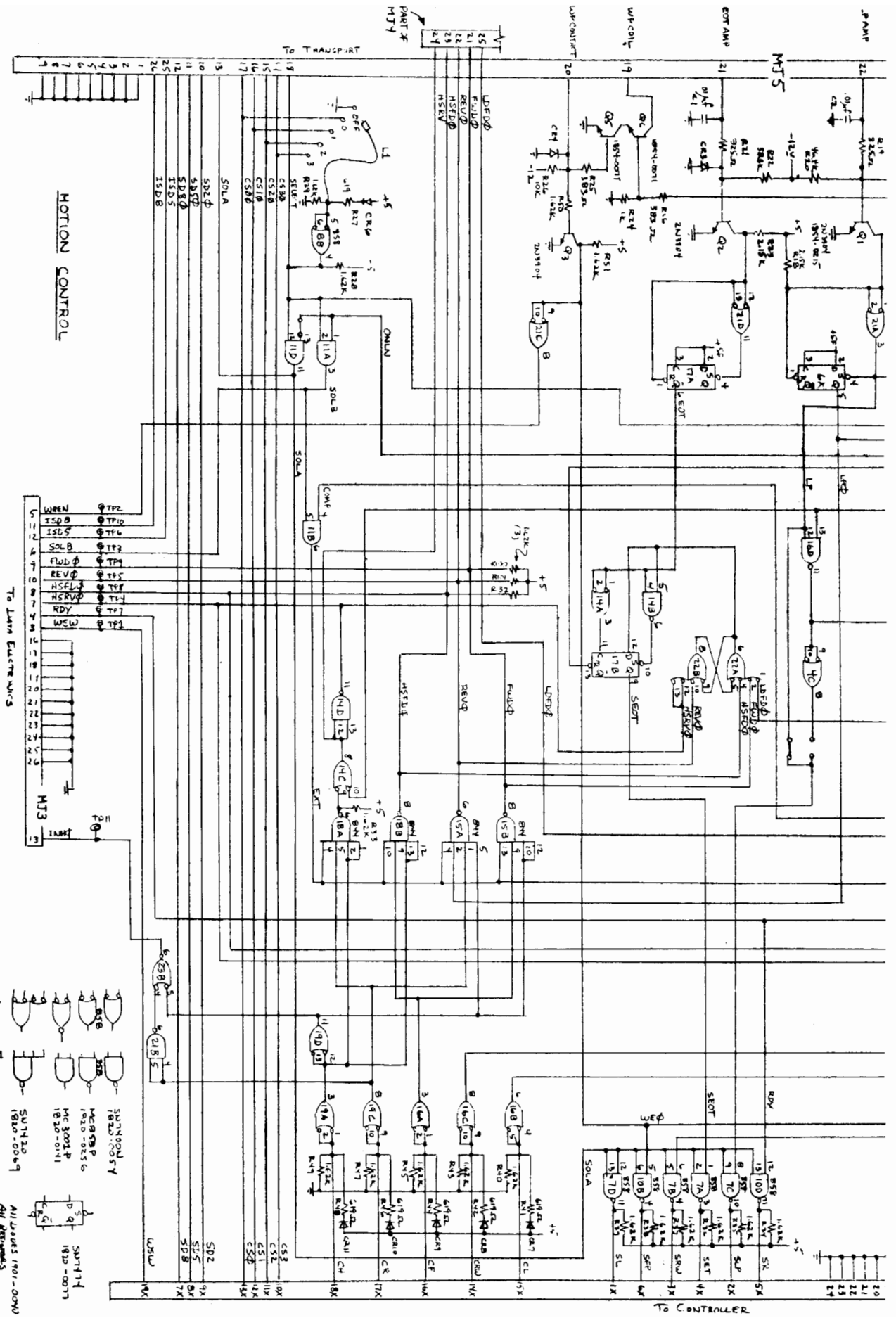
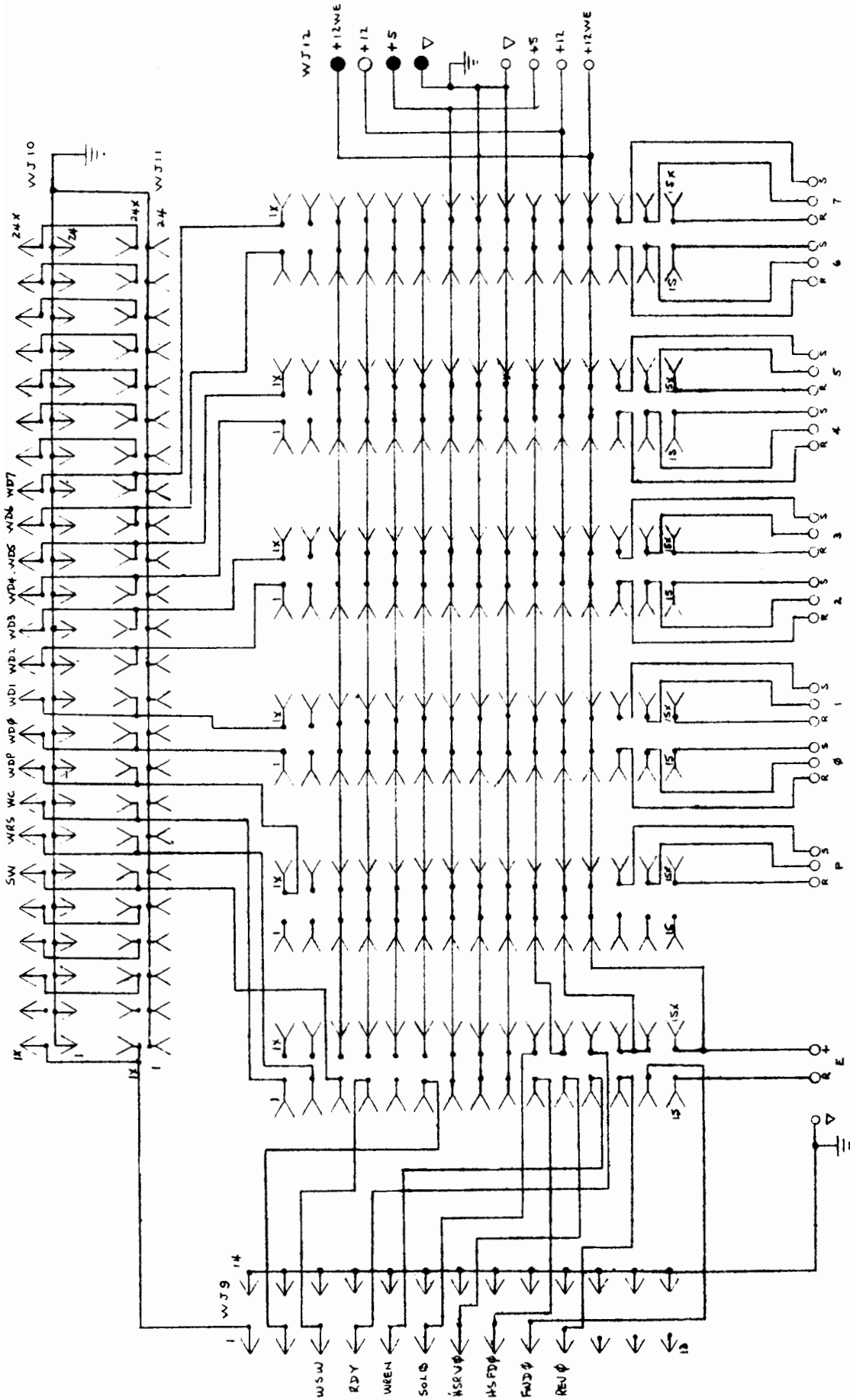

Figure 12-11. Motion Control (A16) Schematic
12-12



- 3024000-FY
 - 1820-0077
 - MC858P 1820-0056
 - MC3003P 1820-0111
 - SW1420 1820-0009
 - MC847P 1820-0318
 - SW1420 1820-0077
 - MC847P 1820-0318
- All Relays 1801-0000
 All Relays 1820-0000
 All Relays 1820-0000



NOTE: WJ12
 ● = MALE MOLEX PIN
 ○ = FEMALE MOLEX PIN

Figure 12-12. Write Interconnect (AI7) Schematic

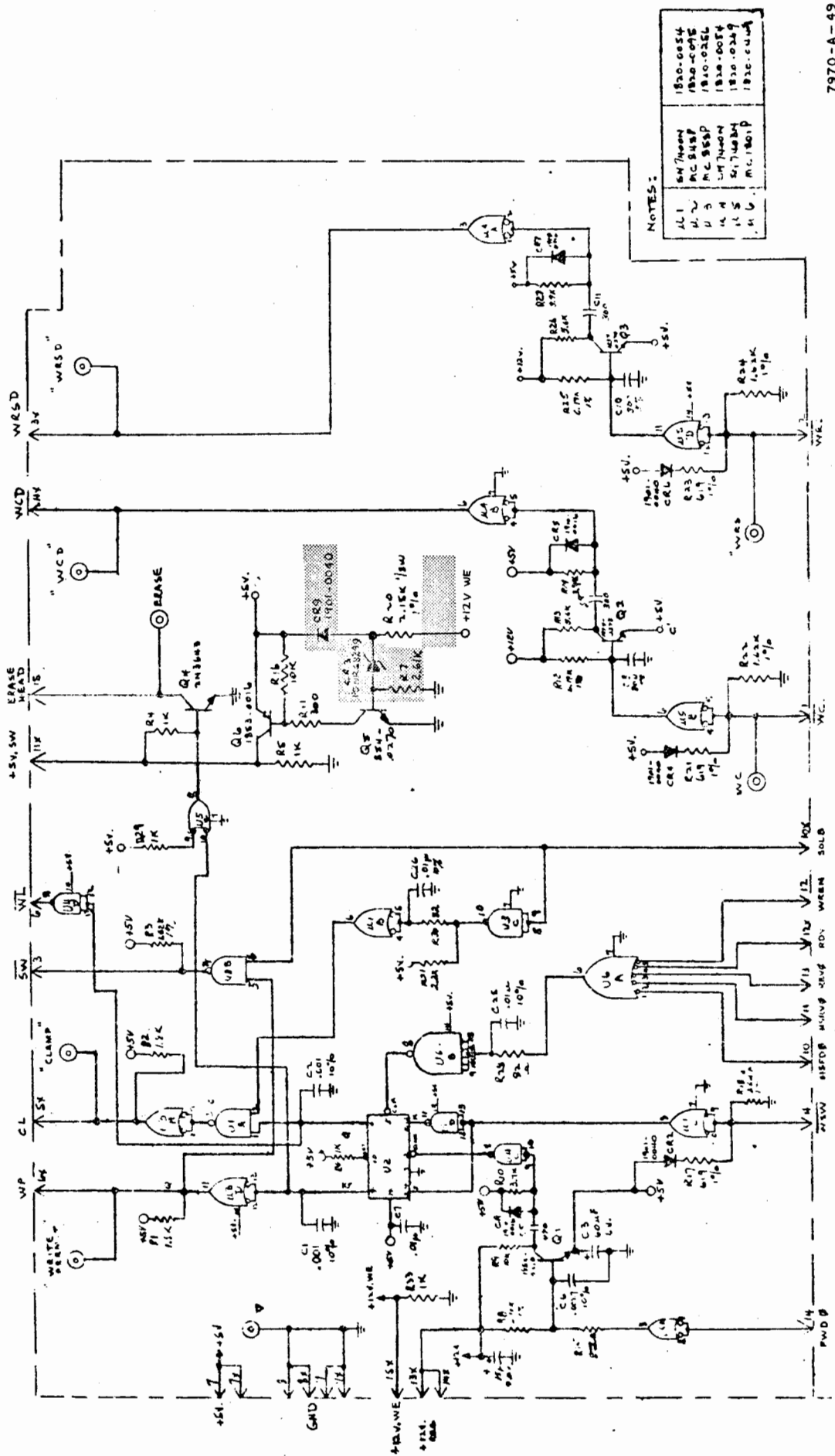

7970-A-49

73

Figure 12-13. Write Control (A17A1) Schematic (Series 1047A)

Figure 12-13. Write Control (A17A1) Schematic

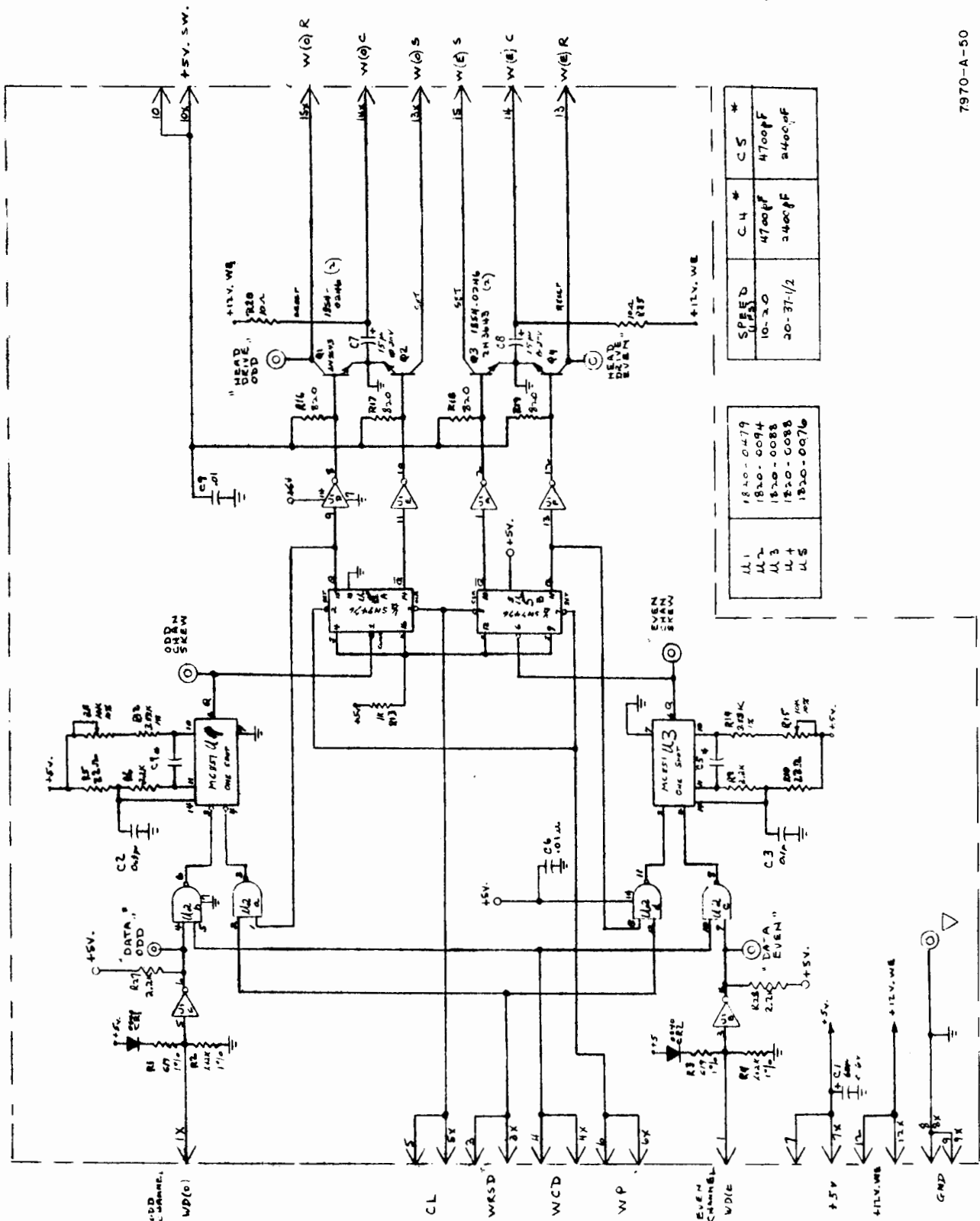

SPEED (US)	C4 #	C5 #
10-20	4700pF	4700pF
20-37-1/2	2400pF	2400pF

U1	1820-0479
U2	1820-0094
U3	1820-0088
U4	1820-0088
U5	1820-0076

7970-A-50

Figure 12-14. Write Data (A17A2 thru A6) Schematic

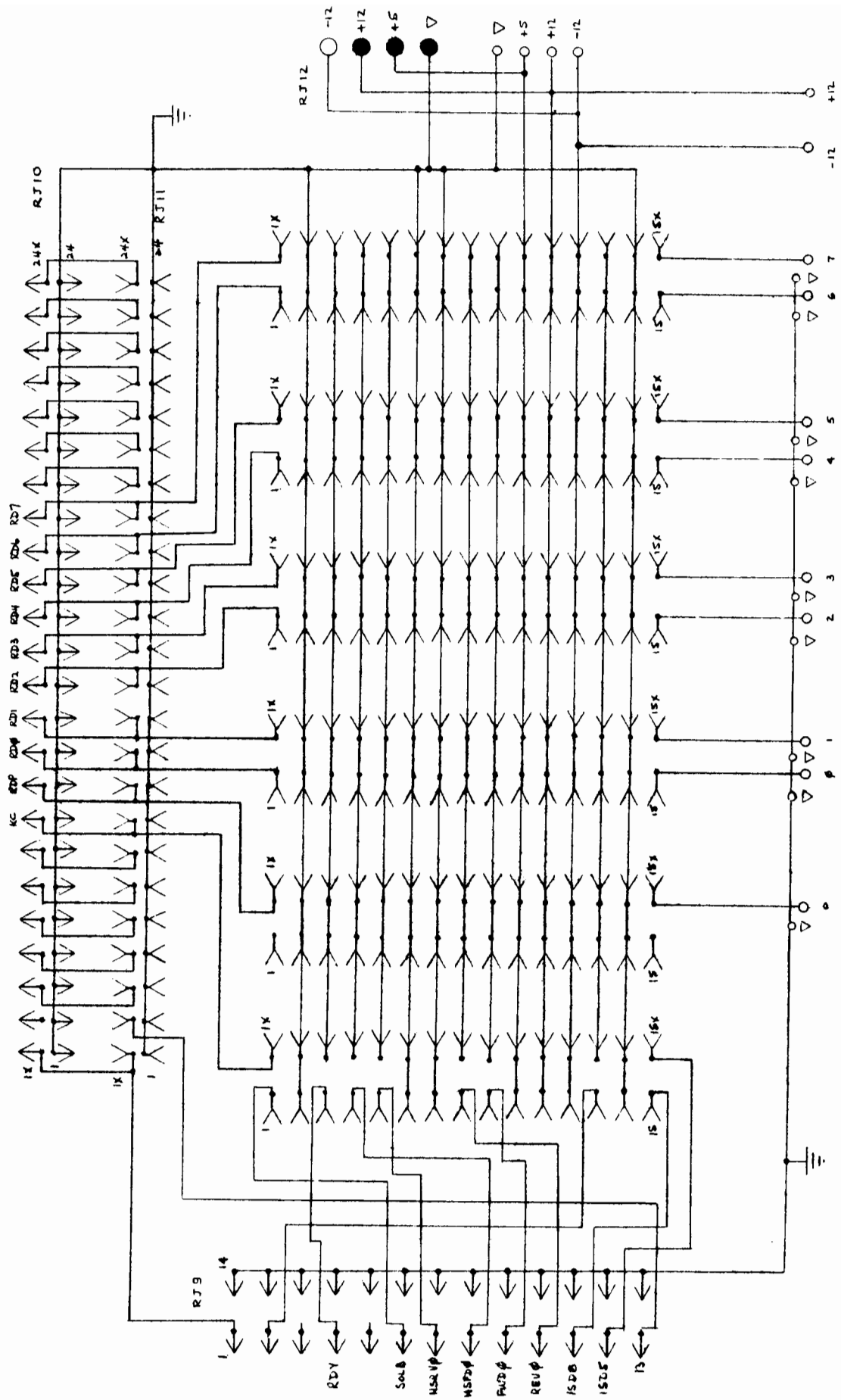

NOTE: RJ12
 ● = MALE MOLEX P.I.N.
 ○ = FEMALE MOLEX P.I.N.

Figure 12-15. Read Interconnect (A18) Schematic

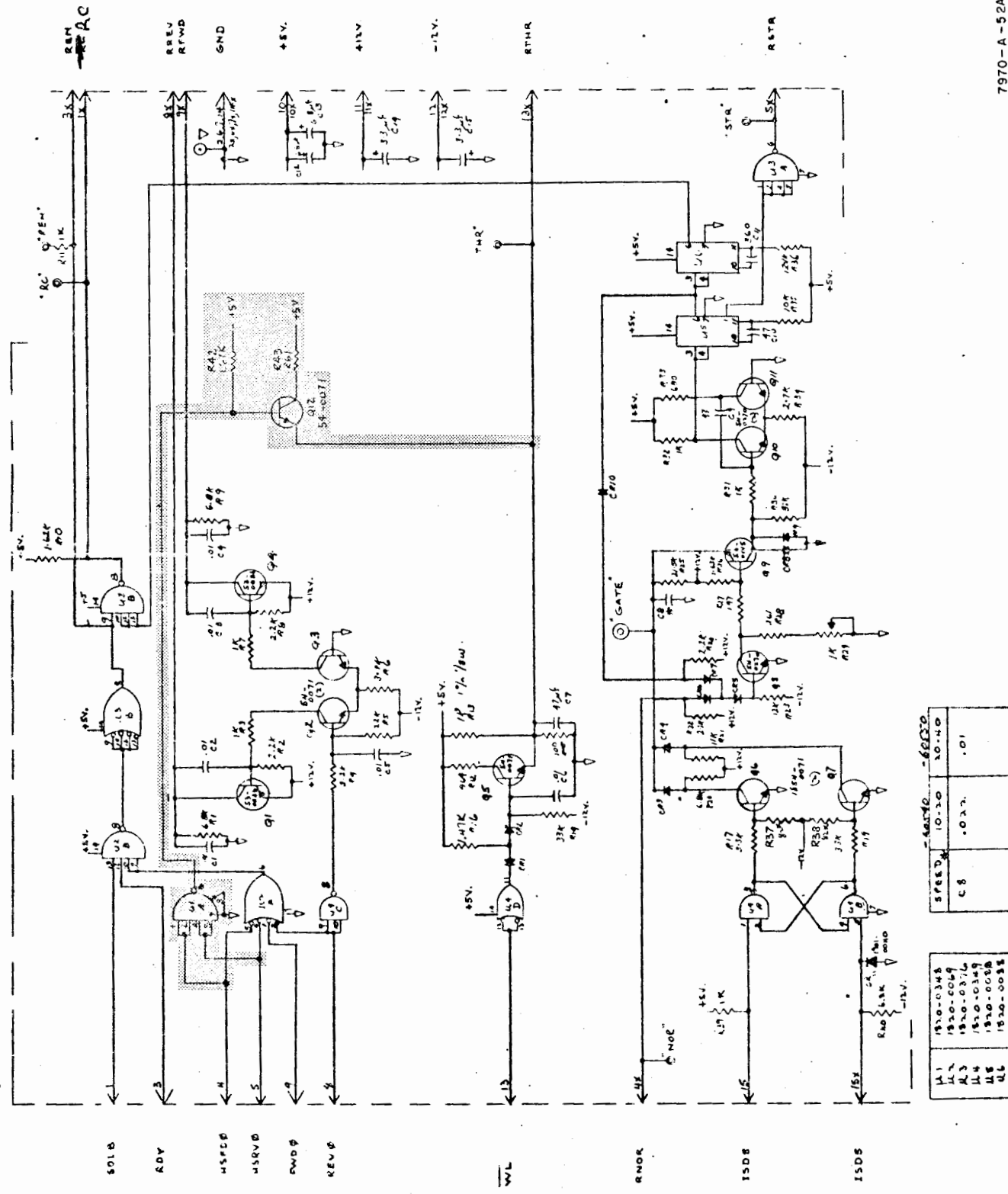

7970-A-52A

Figure 12-16. Read Control (A18Ai) Schematic (Series 1040A)

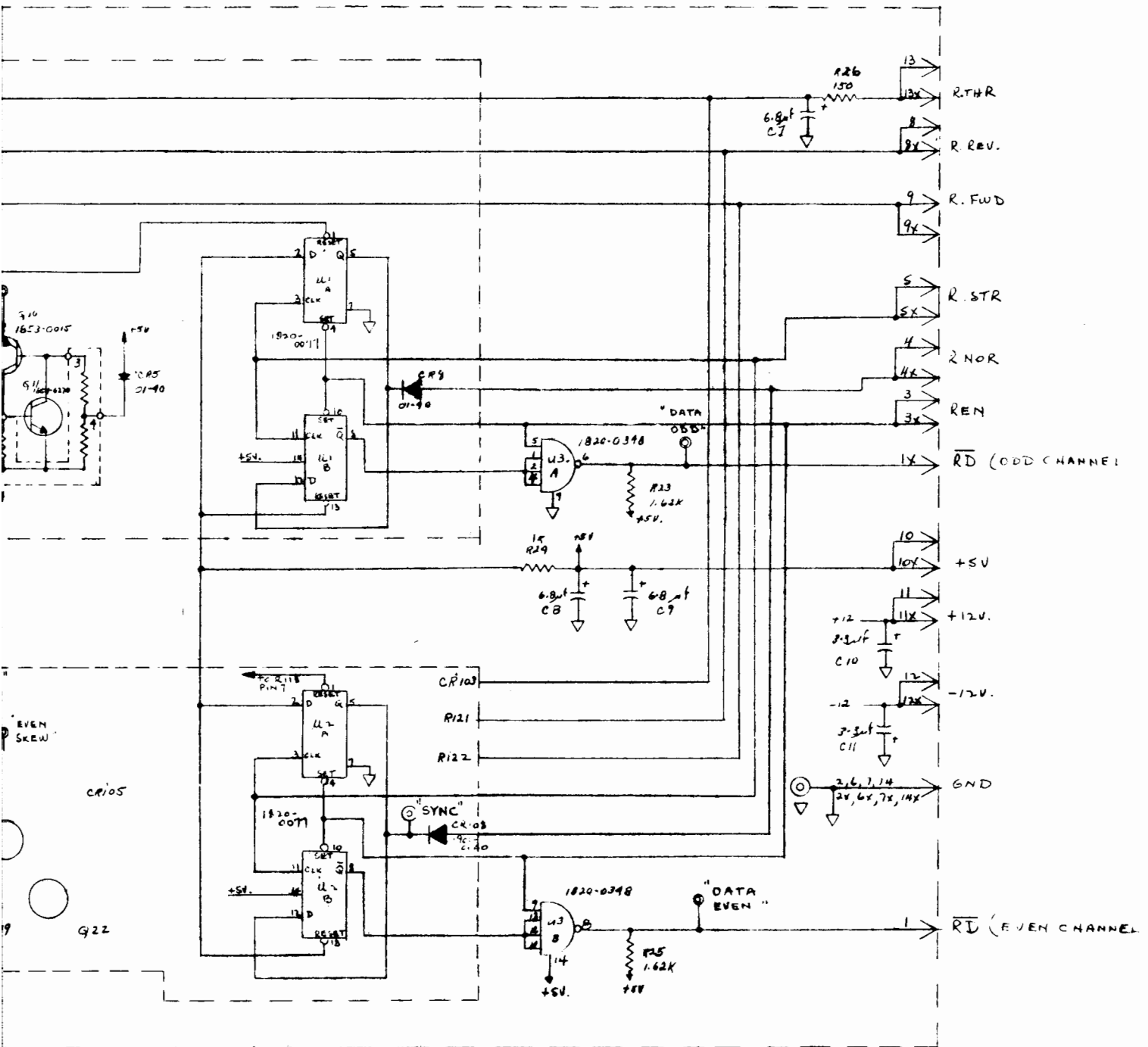

7970-F-53

Figure 12-17. Read Data (A18A2 thru A18A6) Schematic

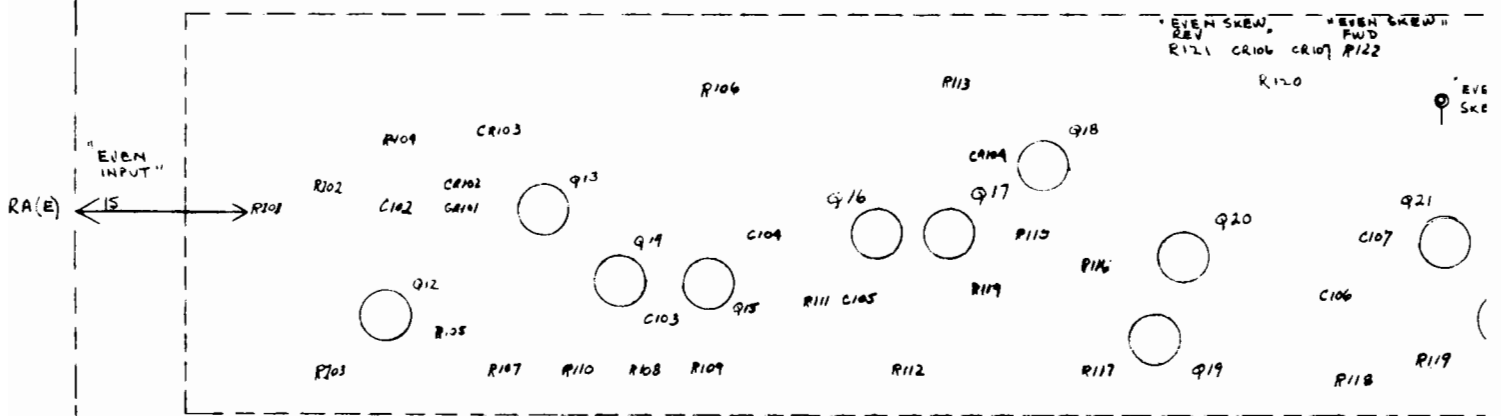
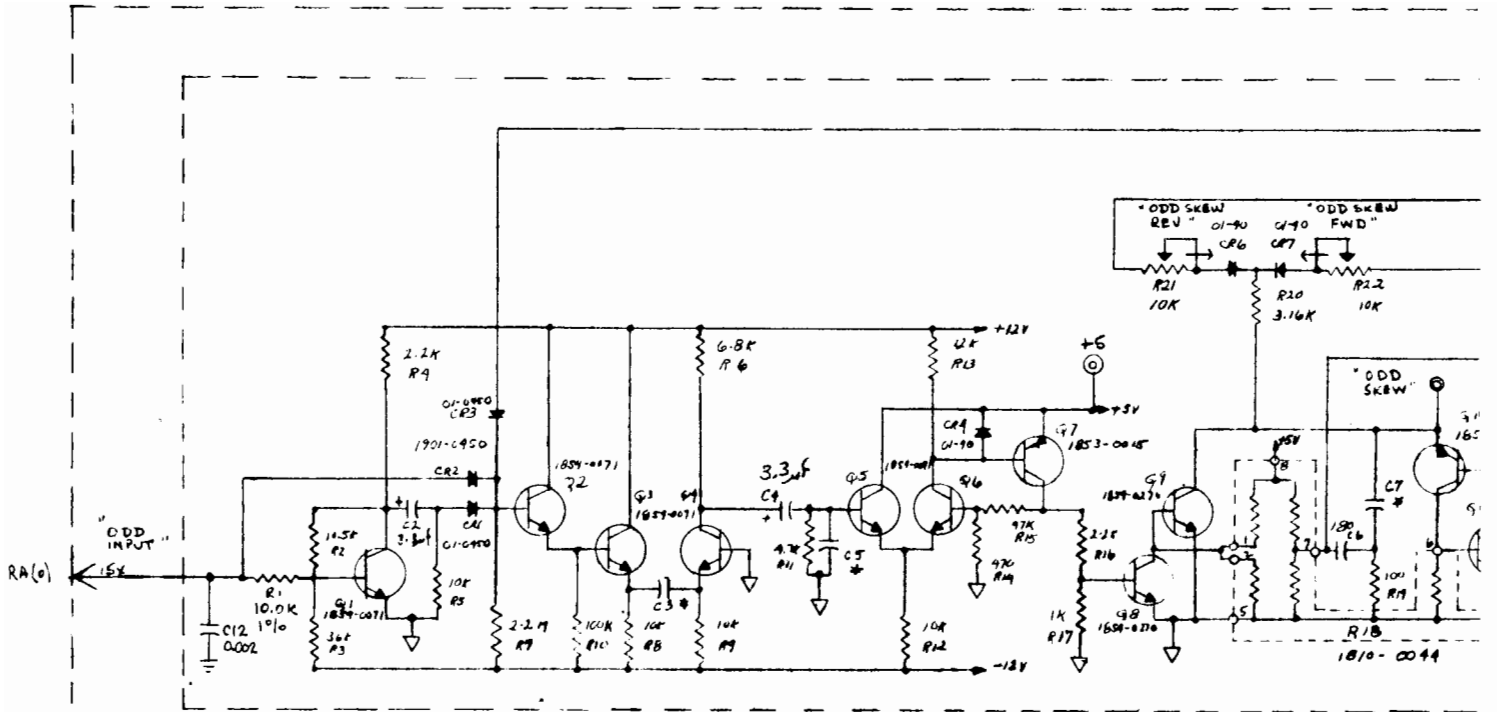

DRAWING	SPEED	C3 C103	C5 C105	C7 C107
07970-60520	10-20	.0082	630pF Disc	.0068
07970-60520	20-37-1/2	.0039	330pF Disc	.0033

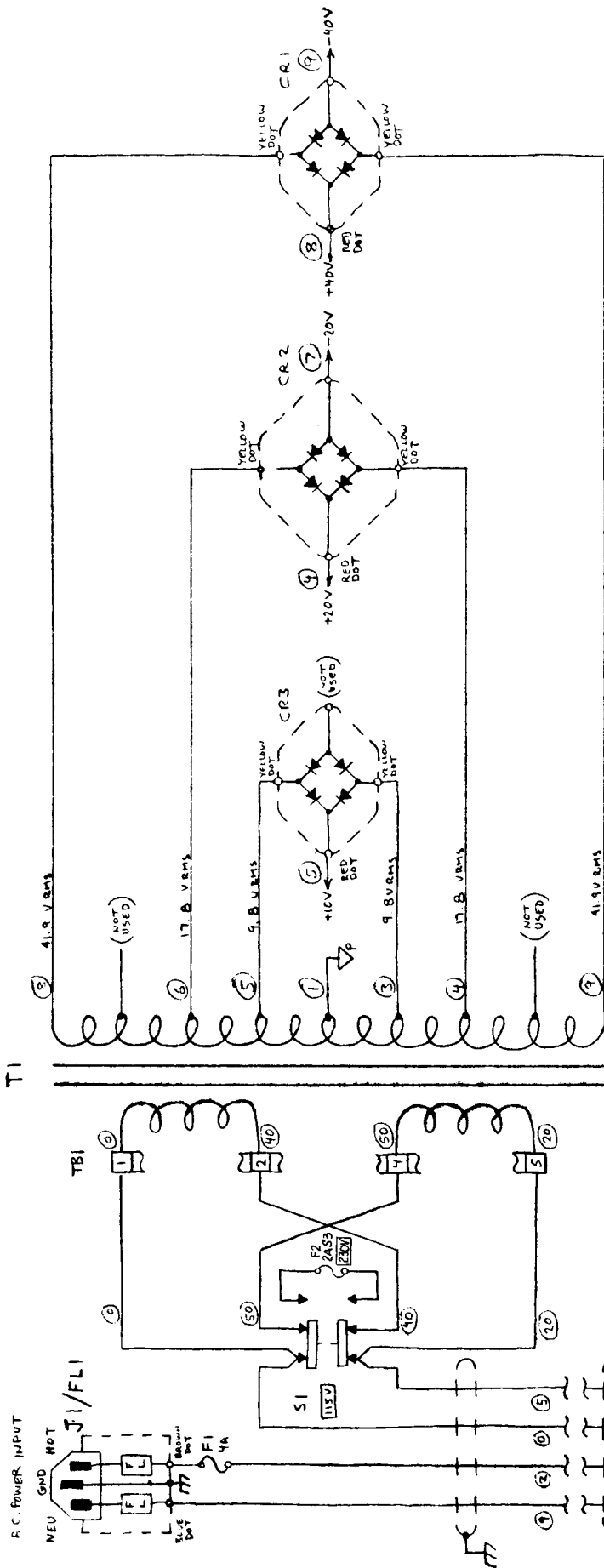

7970-A-54

Figure 12-18. Transformer (A19A1) Schematic

T1

(X) : NUMBERS ENCLOSED IN
A CIRCLE INDICATE
WIRE COLORS

∇ : COMMON, POWER

Add wire code to Figure 12-18, Transformer (A19A1) Schematic, as indicated in the following sketch:

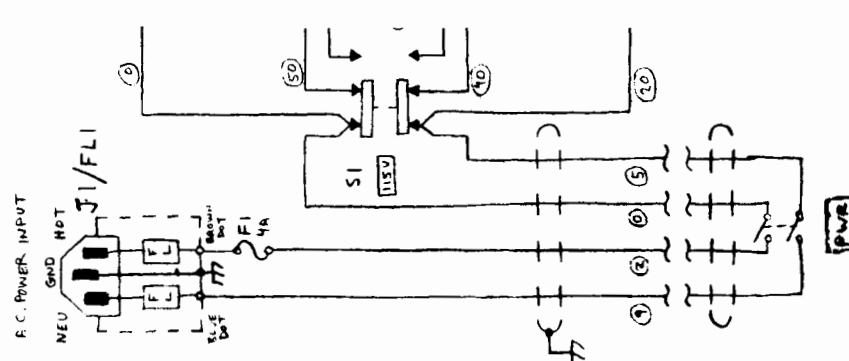
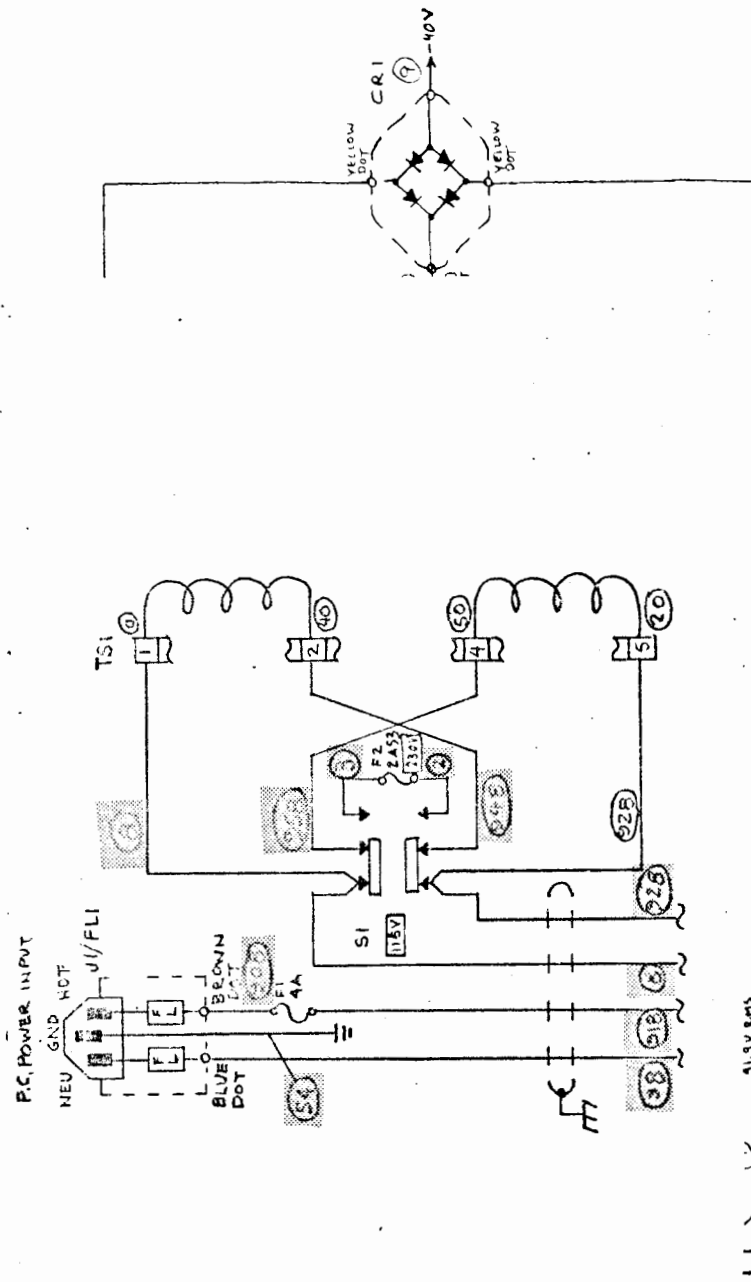

(X) : NUMBERS ENCLOSED IN
 A CIRCLE INDICATE
 WIRE COLORS
 ⚡ : COMMON, POWER



Figure 12-18. Transformer (A19A1) Schematic

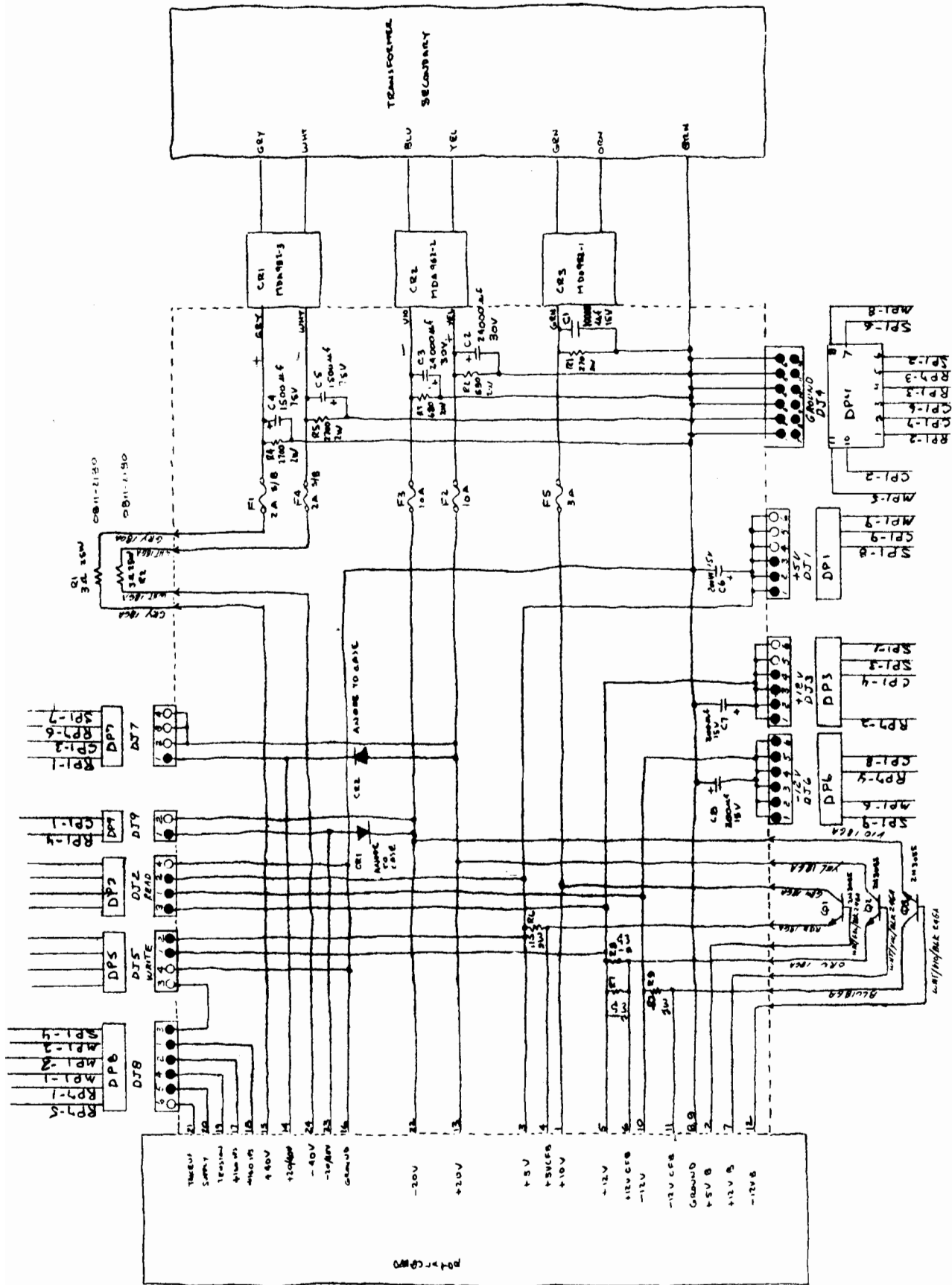
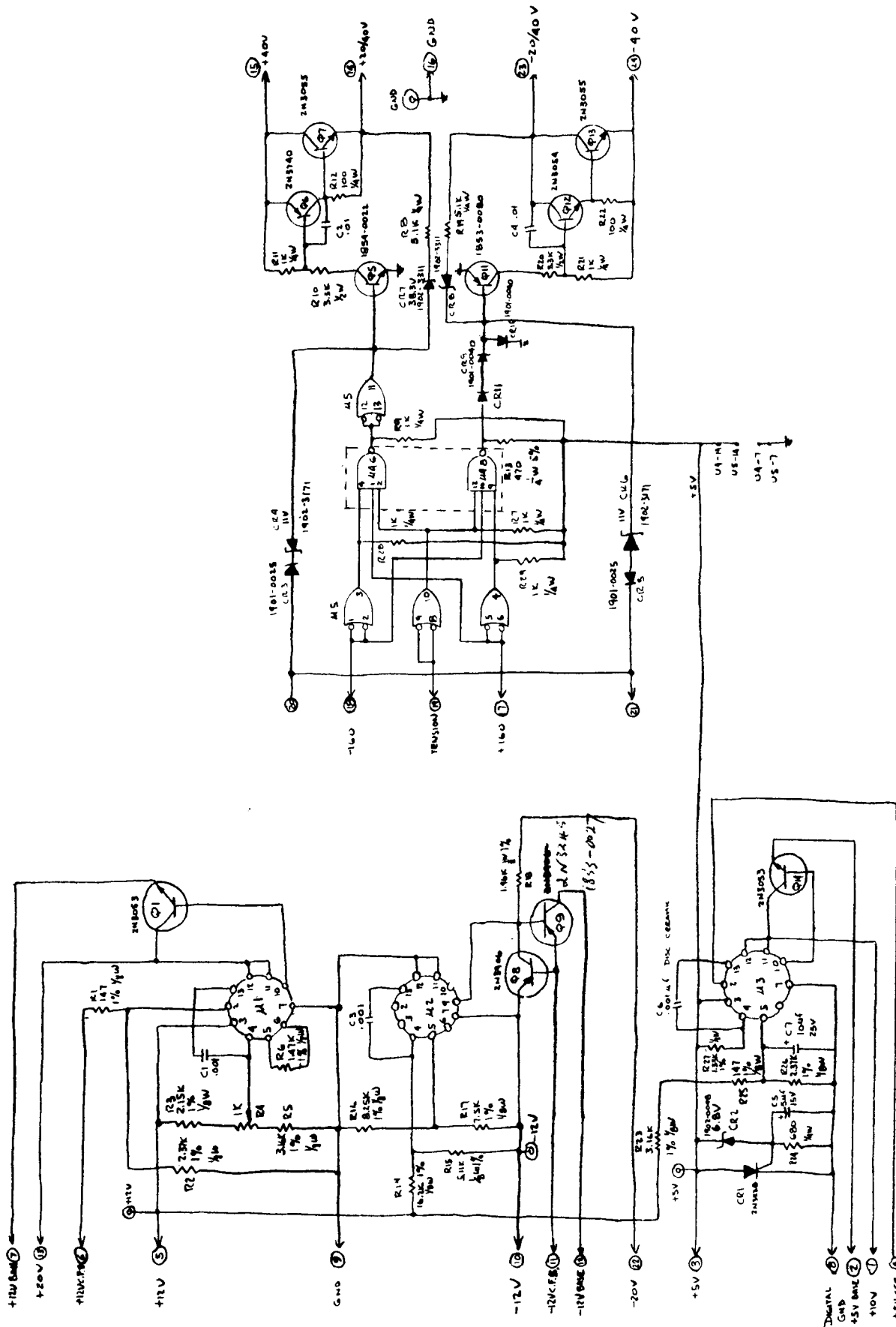
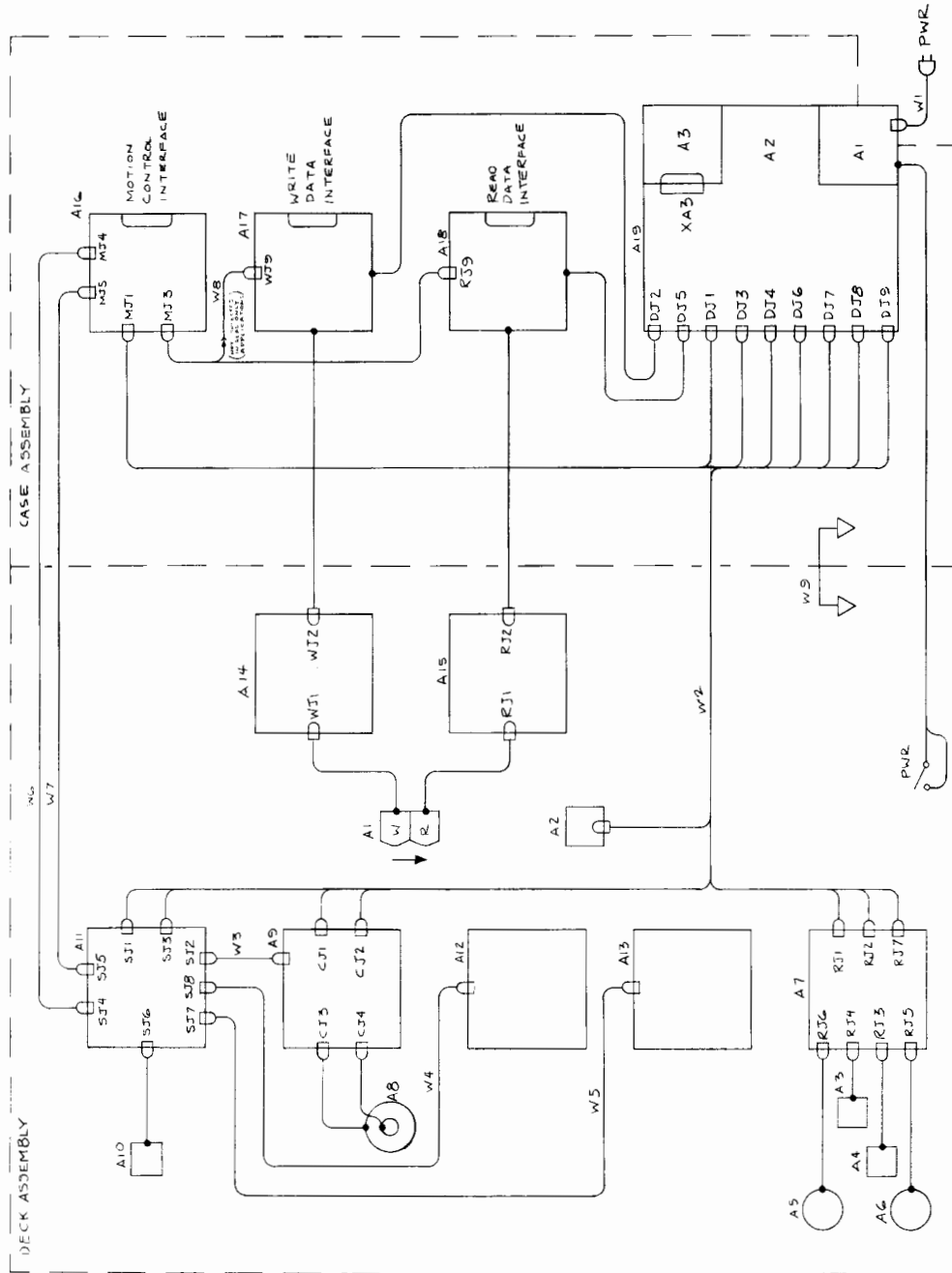

Figure 12-19. Power Supply (A19) Schematic



- A1, A2, A3 see #A728 1820-0057
- A4 MC844P 1820-0540
- A5 MLC56P 1810-025C

Figure 12-20. Power Regulator (A19A3) Schematic



7970-A-57

Figure 12-21. Intercabling Diagram for 7970