

HP 3000 Series 9X7 PA-RISC Computer System
Installation and Configuration Guide

Series 9X7 Family



HP Part No. A1707-92018
Printed in U.S.A. 1993

Second Edition
E0893

Notice

Hewlett-Packard makes no warranty of any kind with regard to this material, including, but not limited to, the implied warranties of merchantability and fitness for a particular purpose. Hewlett-Packard shall not be liable for errors contained herein or for incidental or consequential damages in connection with the furnishing, performance, or use of this material.

Hewlett-Packard assumes no responsibility for the use or reliability of its software on equipment that is not furnished by Hewlett-Packard.

This document contains proprietary information which is protected by copyright. All rights are reserved. No part of this document may be photographed, reproduced, or translated to another language without prior written consent of Hewlett-Packard Company.

The information contained in this document is subject to change without notice.

HP Computer Museum
www.hpmuseum.net

For research and education purposes only.

Printing History

New editions are complete revisions of the manual. Update packages, which are issued between editions, contain additional and replacement pages to be merged into the manual by the customer. The dates on the title page change only when a new edition or a new update is published. No information is incorporated into a reprinting unless it appears as a prior update; the edition does not change when an update is incorporated.

Many product updates and fixes do not require manual changes and, conversely, manual corrections may be done without accompanying product changes. Therefore, do not expect a one-to-one correspondence between product updates and manual updates.

First Edition December 1992
Second Edition August 1993

List of Effective Pages

The List of Effective Pages gives the date of the current edition and of any pages changed in updates to that edition. Within the manual, any page changed since the last edition is indicated by printing the date the changes were made on the bottom of the page. No information is incorporated into a reprinting unless it appears as a prior update.

All December 1992

Safety and Regulatory Information

For your protection this product has been tested to various national and international regulations and standards. The scope of this regulatory testing includes electrical/mechanical safety, radio frequency interference, ergonomics, acoustics, and hazardous materials. Where required, approvals obtained from third-party test agencies are shown on the product label. In addition, various regulatory bodies require some information under the following headings.

FCC Statement (USA only)

The United States Federal Communications Commission (in Subpart J, of Part 15, Docket 20780) has specified that the following notice be brought to the attention of the users of this product:

Warning **This equipment generates, uses, and can radiate radio frequency energy and if not installed and used in accordance with the instructions manual, may cause interference to radio communications. It has been tested for compliance with the limits of Class A computing devices pursuant to Subpart J of Part 15 of FCC Rules, which are designed to provide reasonable protection against such interference.**

Operation of this equipment in a residential area is likely to cause interference in which case the user at his own expense will be required to take whatever measures may be required to correct the interference.

Japanese Radio Frequency Interference

この装置は、第一種情報装置(商工業地域において使用されるべき情報装置)で商工業地域での電波障害防止を目的とした情報処理装置等電波障害自主規制協議会(VCCI)基準に適合しております。

従って、住宅地域またはその隣接した地域で使用すると、ラジオ、テレビジョン受信機等に受信障害を与えることがあります。

取扱説明書に従って正しい取り扱いをして下さい。

Japanese Radio Frequency Notice

For Germany Only

This is to certify that this product meets the Radio Frequency Interference Requirements of Directive 1046/84. The German Bundespost has been notified that this equipment has been put into circulation and has been granted the right to check the product type for compliance with these requirements.

Hersteller- bescheinigung

Hiermit wird bescheinigt, da das Gert/System in bereinstimmung mit den Bestimmungen von Postverfgung 1046/84 funkentstrt sind.

Der Deutschen Bundespost wurde das Inverkehrbringen dieses Gertes/Systems angezeigt und die Berechtigung zur berprfung der Serie auf Einhaltung der Bestimmungen eingerumt.

United Kingdom Only (UK Telecom Statement)

Interconnection of ports marked "WARNING. Connect only apparatus complying with BS6301 to this (these) port(s)", with ports not so marked may produce hazardous conditions on the network and advice should be obtained from a competent engineer before such a connection is made.

Warning **Connect only apparatus complying with BS6301 to the ports of this apparatus.**

Finland (only)

LASERTURVALLISUUS

LUOKAN 1 LASERLAITE
KLASS 1 LASER APPARAT

HP 3000 Series 9x7 ja HP 9000 Model 800 -tietokoneisiin voidaan asentaa lisävarusteena muistilaitteeksi laitteensisäinen CD-ROM-levyasema, joka on laserlaite.

Kyseinen CD-ROM-levyasema on käyttäjän kannalta turvallinen luokan 1 laserlaite. Normaalisissa käytössä levyaseman suojakotelo estää lasersäteiden pääsyn laitteen ulkopuolelle.

CD-ROM-levyaseman on tyyppihyväksynyt Suomessa laserturvallisuuden osalta Työministeriön työsuojeluosasto. Laitteen turvallisuusluokka on määritetty valtioneuvoston päätöksen N:o 472/1985 ja standardin SFS-EN 60825 (1992) mukaisesti.

Tiedot CD-ROM-levyasemassa käytettävän laserdiodin säteilyominaisuuksista:

Aallonpituus 780 nm
Teho 0,4 mW
Luokan 1 laser

Safety Considerations

This product and related documentation must be reviewed for familiarization with safety markings and instructions before operation. The following figure shows some of the safety symbols used on the product to indicate various safety considerations.

Warning **The WARNING sign denotes a hazard. It calls attention to a procedure, practice, of the like, which if not done correctly or adhered to, could result in injury. Do not proceed beyond a WARNING sign until the indicated conditions are fully understood and met.**

Caution The CAUTION sign denotes a hazard. It calls attention to an operating procedure, practice, of the like, which if not done correctly or adhered to, could damage or destroy part or all of the product. Do not proceed beyond a CAUTION sign until the indicated conditions are fully understood and met.

Warning ■ **A wheel is located in the center of this system so it can be easily positioned.**

 ■ **Use care when moving the system on a cart. Do not allow the system to move or roll off the cart.**

 ■ **The system is designed as a floor standing product. It could be used on a table top if precautions are taken:**

- **Make sure the table will support the weight, and**
- **Make sure the table is stable (will not tip over), and**
- **Do not allow the system to move on the table, and**
- **Do not push the system when it is on the table.**

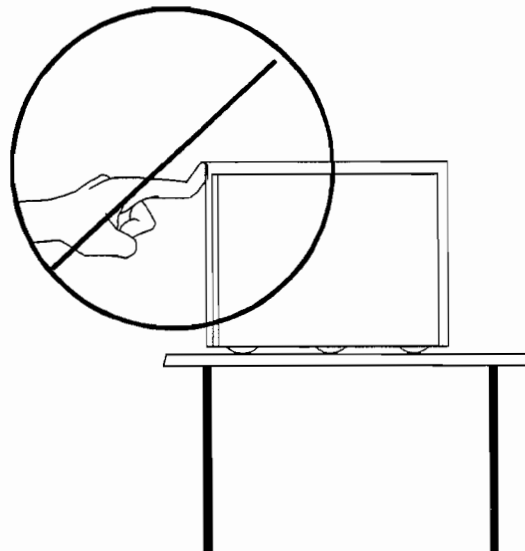

■ **Failure to follow these procedures may result in personal injury.**

Preface

This manual is intended for use by trained and experienced Hewlett-Packard field maintenance personnel. This edition of the *Installation and Configuration Guide* contains technical information about the HP 3000 Series 9X7 Family of computers listed in the table below.

HP 3000 9X7 Models

| | 917 32MHz | 927 32MHz | 937 32MHz | 947 32MHz | 957 48MHz | 967 48MHz | 977 64MHz | 987 96MHz | 987/150 96MHz |
|-----------|----------------------|----------------------|----------------------|----------------------|----------------------|----------------------|----------------------|----------------------|--------------------------|
| LX | Yes | Yes | Yes | Yes | No | No | No | No | No |
| RX | No | No | Yes | Yes* | Yes* | Yes* | No | Yes | Yes* |
| SX | No | No | Yes | Yes* | Yes* | Yes* | Yes* | Yes* | Yes* |

Model

Chassis Type

LX 2 I/O slot chassis
RX 4 I/O slot chassis
SX 12 I/O slot chassis

* These models are available with an optional Openview Console package referred to as the HP 3000 9X7RX/SX PLUS System.

Other Documents Referenced in this Guide:

| Part Number | Title |
|--------------------|---|
| A1707-92014 | <i>HP 3000 Site Preparation Guide</i> |
| A1707-90016 | <i>HP 3000 and HP 9000 CE Handbook</i> |
| B3118-90001 | <i>HP OpenView Console User's Guide</i> |
| B3118-90002 | <i>HP OpenView Console Manager's Guide</i> |
| 5958-5859 | <i>Computer Products Site Preparation Resources Guide</i> |
| 5958-2370 | <i>HP CEO Site Preparation Handbook</i> |



Contents

| | |
|---|-----|
| 1. About This Manual | |
| 2. Site Considerations | |
| Site Preparation Considerations | 2-1 |
| Hewlett-Packard Service Organization | 2-2 |
| Sales Representative | 2-2 |
| Customer Engineer | 2-2 |
| Applications Engineer | 2-2 |
| Hewlett-Packard Site Preparation Services | 2-2 |
| Site Planning Visit | 2-2 |
| Site Verification at Installation | 2-2 |
| Third Party Service | 2-3 |
| Customer Responsibilities | 2-5 |
| Local Codes | 2-5 |
| Data Communications Equipment | 2-5 |
| 3. Receiving The System | |
| Unpacking and Inspection | 3-1 |
| Unpack the HP 3000 9X7LX Computer | 3-1 |
| Unpack the HP 3000 9X7RX/SX Computer: | 3-4 |
| In Case of Damage | 3-7 |
| Physical Inventory | 3-8 |
| Manuals | 3-8 |
| Equipment | 3-8 |
| Computer | 3-8 |
| Claims Procedures | 3-8 |
| Repacking | 3-9 |
| Storage Requirements | 3-9 |
| 4. Installation | |
| Installation Procedures | 4-1 |
| SPU Installation | 4-1 |
| System Console Installation | 4-3 |
| DTC Installation | 4-3 |
| Installation Completion | 4-4 |

| | |
|---|------|
| 5. Starting the Computer System | |
| Turning On the Computer System | 5-1 |
| Initial Power On | 5-2 |
| To identify the computer's first displays | 5-2 |
| Installation Verification | 5-6 |
| Verifier global status messages | 5-6 |
| Verifier log file | 5-7 |
| | |
| A. Remote Support Modem Configuration | |
| Quick Reference | A-2 |
| HP Support Link (HP50759A) | A-2 |
| Hayes Smartmodem 2400 | A-4 |
| Black Box V.32 Plus (Version 2.01.01) | A-5 |
| Multitech MT224EH7 | A-6 |
| HP 37212B | A-7 |
| Modem Cable Pin-out | A-8 |
| Multifunction I/O PCA Modem Line Behavior | A-9 |
| CCITT Mode AP protocol 0 | A-9 |
| Bell Mode AP protocol 1 | A-9 |
| CCITT_BIS Mode AP protocol 2 | A-10 |
| Modem Settings (Predictive Support) | A-10 |

Figures

| | |
|---|-----|
| 3-1. Removing Loose Parts | 3-2 |
| 3-2. Positioning the Shipping Box | 3-2 |
| 3-3. Raising the Flap | 3-3 |
| 3-4. Removing the Computer from the Box | 3-3 |
| 3-5. Removing the Outer Shipping Box | 3-5 |
| 3-6. Unpacking the Accessories | 3-6 |
| 3-7. Lowering the Ramp | 3-7 |



Tables

| | |
|--|------|
| 2-1. Technical Tasks/Personnel | 2-4 |
| 4-1. Example Power Consumption Worksheet | 4-2 |
| 5-1. START with 1, 2, 3, or 4 Disk Drives | 5-4 |
| A-1. Settings for Remote Support Modem (Quick Reference) | A-2 |
| A-2. 8-Position DIP Switch Option Settings (Set S) | A-3 |
| A-3. 4-Position DIP Switch Option Settings (Set X) | A-3 |
| A-4. Switch Option Settings | A-4 |
| A-5. HP 37212B Switch Configuration | A-8 |
| A-6. 92219Q Cable Pin-out | A-9 |
| A-7. Predictive Support Modems and Switch Settings | A-11 |



About This Manual

This manual contains the installation instructions for the HP 3000 Series 9X7 LX/RX/SX Family Computer Systems.

This manual also contains information for installing the Distributed Terminal Subsystem and for configuring modems for remote support. This manual does not include instructions for installing networks.

This manual is organized as follows:

Chapter 1 About This Manual. Introduces the manual and describes its organization.

Chapter 2 Site Considerations. This chapter defines HP organizations and lists site preparation responsibilities.

Chapter 3 Receiving The System. This chapter provides information on receiving the system, instructions for unpacking the system, and putting it into position.

Chapter 4 Installation. Contains installation procedures and configuration information.

Chapter 5 Starting the Computer System. Provides instructions for turning on the equipment, booting MPE/iX, and running the verification program.

Appendix A Support Link Modem Configuration. Provides configuration information on a number of modems that can be used for the support link modem.



Site Considerations

This chapter lists the HP organizations and services available for site preparation for the HP 3000 9X7 family computers. It also lists and describes the responsibilities of the customer.

The HP 3000 Series 9X7 family computers are fully integrated computers that include up to three embedded disk drives and one Digital Data Storage (DDS) tape device.

In addition to the embedded peripherals, each system supports external peripherals that are connected to the computer through HP-IB or HP-FL interface cards. Terminals and serial printers are connected to the computer through a Distributed Terminal Subsystem connected to a Local Area Network (LAN). HP 3000 models use the MPE/iX operating system.

Site Preparation Considerations

This section contains site preparation information for the HP 3000 Series 9X7 Computer Systems. The CE or Site Preparation Specialist provides peripheral equipment power and environmental specifications contained in the *HP CEO Site Preparation Handbook* and the *HP 3000 and HP 9000 CE Handbook*.

Proper site preparation is vital to the reliability of any computer system. As our customer, it is your responsibility to ensure that the facility conditions are maintained in accordance with the information and specifications contained in the *HP Site Preparation Guide* and the *Site Preparation Resource Guides*. Refer the *Preface* for manual part numbers.

This allows Hewlett-Packard to provide support services in accordance with the *Customer Support Services Agreement*.

The HP 3000 Series 9X7 computers are primarily designed to be used in commercial office environments. Except for verifying the environment and AC power, very little site preparation is required. When the computer is configured into a larger system employing numerous peripherals and mass storage devices, you should study and become more familiar with the contents of this manual and the *Computer Products Site Preparation Resource Guides*.

Be aware that the HP 3000 Series 9X7RX/SX computer requires two power outlets for the two power cords that attach to the computer. Be sure to have enough outlets for all the peripheral equipment that comes with the computer system.

Hewlett-Packard Service Organization

Each member of the Hewlett-Packard service organization is dedicated to making sure that each customer realizes maximum benefits from their computer system. Brief descriptions of Hewlett-Packard service representatives and how they can assist you are contained in the following paragraphs. Table 2-1 summarizes a number of site preparation technical tasks and lists the personnel who should be responsible for completing each task.

Sales Representative

The Hewlett-Packard Sales Representative is the customer's primary point of contact. Each Sales Representative coordinates all of the Hewlett-Packard resources required to ensure a successful delivery schedule and installation. The Sales Representative is also responsible for arranging additional system capabilities and staff training where necessary.

Customer Engineer

The Hewlett-Packard Customer Engineer (CE) is trained and experienced in computer equipment and peripherals service, with the tools, parts, and knowledge to install and maintain Hewlett-Packard computer systems.

Applications Engineer

The Hewlett-Packard Applications Engineer (AE) is technical specialist for HP 3000 systems and programming languages. The AE organization provides a host of training courses and technical consulting services in support of your computer system's languages, utility programs, data base management, and system performance.

Hewlett-Packard Site Preparation Services

The following paragraphs outline Hewlett-Packard's site planning and verification services.

Site Planning Visit

Upon receipt of a purchase order, a Hewlett-Packard Customer Engineer (CE) will make arrangements for an on-site meeting with the customer's Principal Operator and electrician. As a part of this on-site meeting, the CE will discuss site planning and preparation needs, including electrical, mechanical, and physical requirements. The forms in Section 2 of the *Computer Products Site Preparation Resource Guide* will be completed at this time.

As a result of this visit, a site layout plan agreeable to the customer and HP will be created. All of your system requirements and specifications are contained in either this manual or the *Computer Products Site Preparation Resource Guide*.

Site Verification at Installation

The Hewlett-Packard CE verifies that your site meets or exceeds your computer system's requirements and specifications during system installation.

Hewlett-Packard provides service under the conditions of the Computer Products Warranty & Installation Terms, Customer Support Services Agreement, Installation Support Plan, and on a time and material basis. (Refer to Section 1 of the *Computer Products Site Preparation Resource Guide*.)

2-2 Site Considerations

Third Party Service

If an HP 3000 Series 9X7 Computer system and/or applications software is purchased from a "third party vendor", that third party is responsible for providing consultation services on the system operation and applications software.

In the situation of a third party purchase, a maintenance agreement for hardware and Account Management Service (AMS) for software are available directly from Hewlett-Packard.



Table 2-1. Technical Tasks/Personnel

| Technical Task | Person Responsible |
|--|---------------------|
| Line voltage measured | Electrician and CE |
| Power line frequency measured | CE |
| Power line noise levels measured | CE |
| Neutral to ground levels measured | CE |
| Safety and ground connections verified | Electrician and CE |
| Advice on correct circuit breakers and wire sizes | Electrician and CE |
| Verification that maintenance power outlets (those used for floor cleaning, etc.) are on separate circuits from the computer system. | Electrician |
| Recommendations about lightning protection | CE |
| Measurements and recommendations on radiated interference | CE |
| Answers to questions concerning modems and modem options | CE |
| Thermal load of HP equipment | CE |
| Thermal load of non-HP equipment | Customer/Vendor |
| Total air conditioning required | Customer/Contractor |

2-4 Site Considerations

Customer Responsibilities

The customer is responsible for scheduling, planning, and preparing a suitable environment for the complete computer system. The Hewlett-Packard CE will be available to assist you throughout the planning and preparation for and the installation of the system.

In the *Computer Products Site Preparation Resource Guide*, read the Site Planning and Warranty Information (Section 1) and the On-Site Customer Documents (Section 2). Pay particular attention to the contents of the Customer Responsibilities page in Section 1 and the forms contained in Section 2. (The forms in Section 2 will be completed as the site planning preparation and equipment installation progresses.)

Local Codes

Special local codes exist in some locations regulating the installation of computer equipment. The customer is responsible for making sure the system is in compliance with all local laws, regulations, and codes for mechanical, building, and electrical distribution systems prior to system installation.

Data Communications Equipment

The customer is responsible for ordering and installing all required data communications equipment such as:

- Modems (Consult with CE for Hewlett-Packard requirements.)
- Telephone equipment
- Equipment supplied by companies other than Hewlett-Packard
- Any hardware or cables for connection or installation



Receiving The System

This chapter contains information for unpacking and inspecting the computer, taking inventory of shipped goods, filing claims, repacking, and storing the system.

Unpacking and Inspection

The computer and its accessories may be shipped in more than one container. First, check to ensure that all the containers ordered by the customer are present, as specified in the carrier's Bill of Lading. Inspect each container for evidence of mishandling during transit. If any of the containers are damaged, request that the carrier's agent be present when the container is opened.

Unpack the shipping containers and inspect each item for damage. Look for damage such as broken controls and connectors, dented corners, scratches, bent panels, and loose components. Check the rigid foam packing material for signs of damage, which could indicate rough handling during transit.

Unpack the HP 3000 9X7LX Computer

The unpacking of the computer is shown on the flap of the shipping box. To remove the computer from the shipping box, perform the following steps:

Warning *DO NOT* try to lift the computer out of the shipping box. The shipped weight of the computer exceeds 70 pounds (32 kg). If the computer is dropped it could cause injury and will cause damage to the internal components of the computer.

1. Remove all loose parts inside the shipping box, and the inside shock absorbing packing materials. See Figure 3-1.

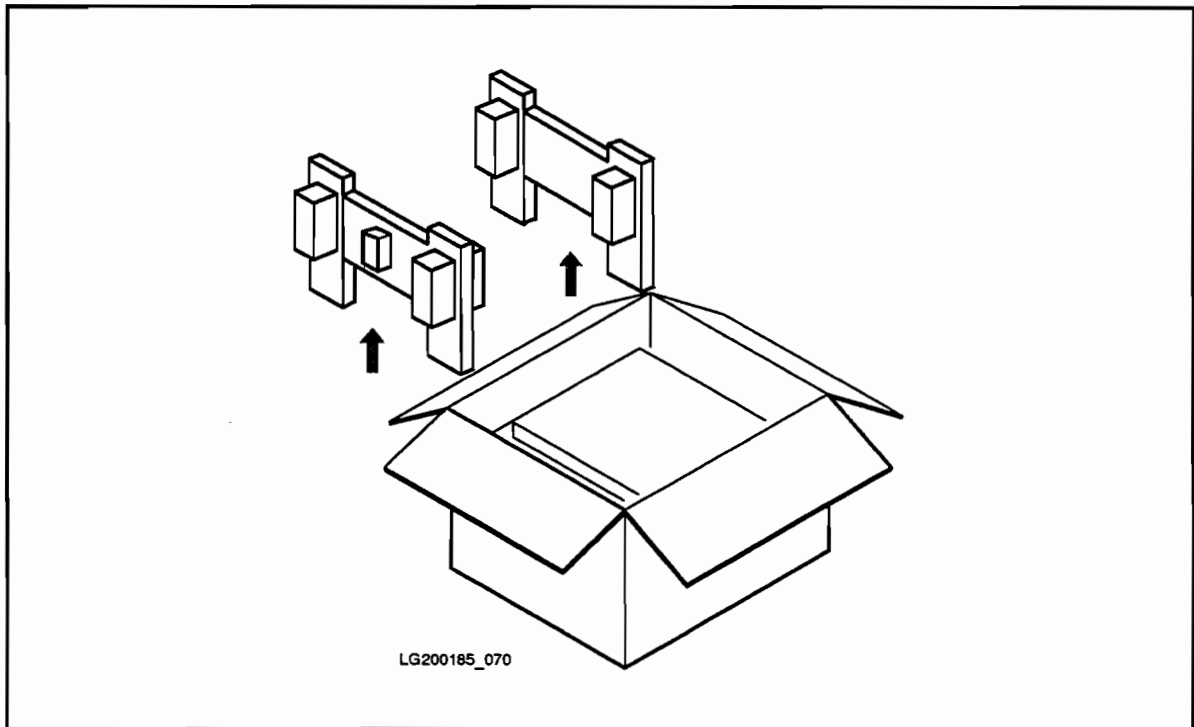

Figure 3-1. Removing Loose Parts

2. Close the flap with the handles cut in it, the other three flaps should be open.
3. Position yourself so that you must reach across the box to grasp the handles. See Figure 3-2.

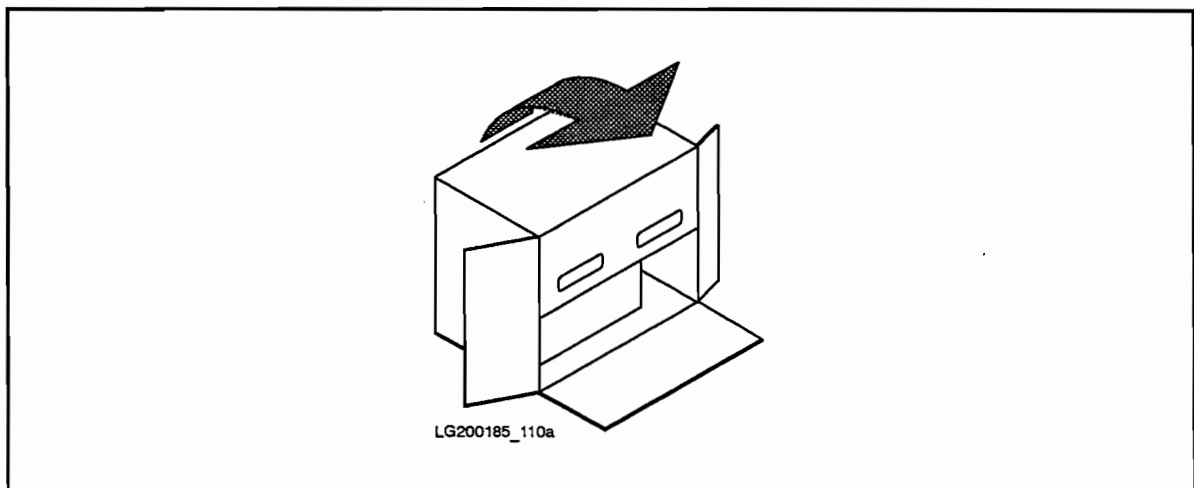

Figure 3-2. Positioning the Shipping Box

3-2 Receiving The System

4. Grasp the handles and carefully pull the shipping box toward yourself until the shipping box rests on its side, with the handles on top. This positions the computer in an up right position resting on its feet. See Figure 3-2.

Note The feet on the bottom of the computer slide easily on cardboard. They should also slide easily over hard floors or carpets.

5. Open the top flap. See Figure 3-3. Reach into the shipping box and grasp the computer on the left and right side.

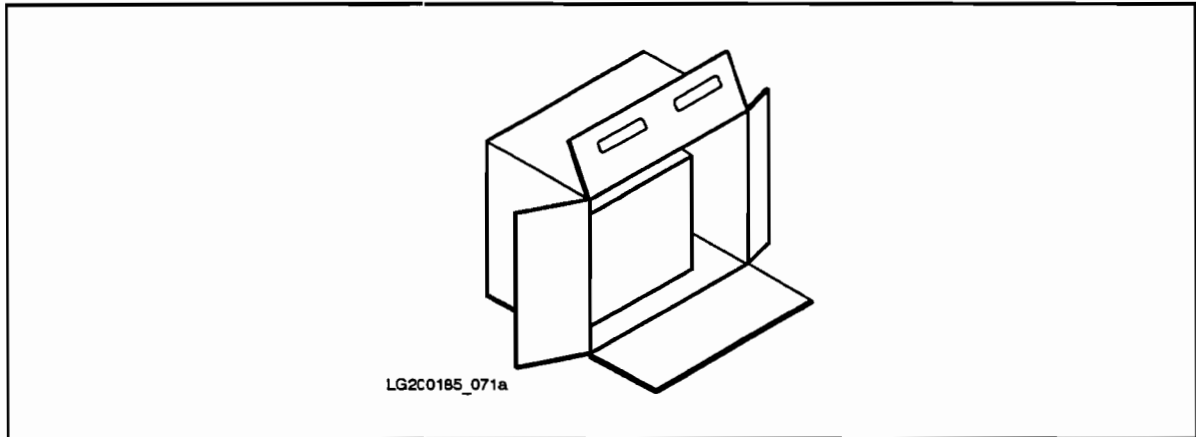

Figure 3-3. Raising the Flap

6. Pulling alternately with your left and right hand, slowly slide the computer out of the shipping box. See Figure 3-4. Save the shipping box and packing materials in case the computer needs to be moved to another location.

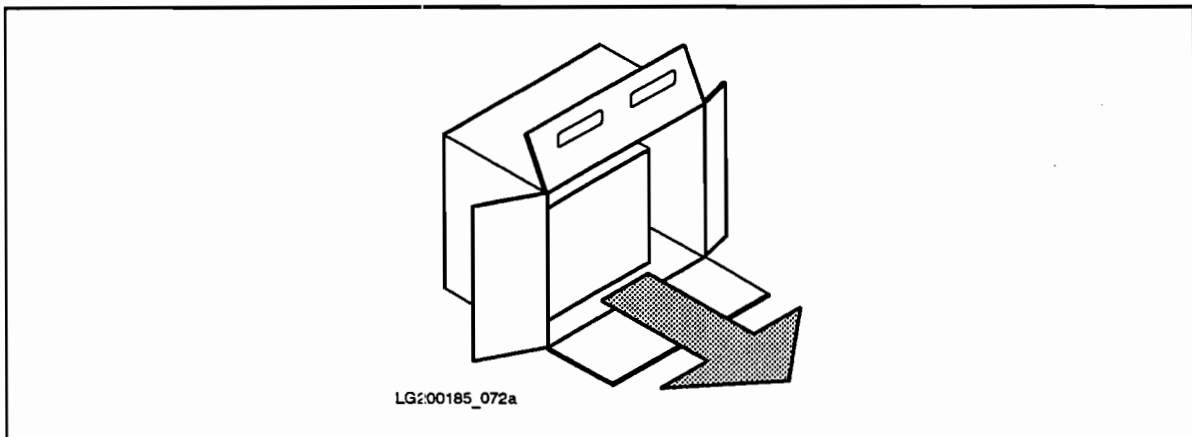

Figure 3-4. Removing the Computer from the Box

Unpack the HP 3000 9X7RX/SX Computer:

Warning *DO NOT* try to lift the computer out of the shipping box. The shipped weight of the computer can exceed 110 pounds (50 kg). If the computer is dropped it could cause injury and will cause damage to the internal components of the computer.

1. Put the computer package close to its installation site.
 2. Position the container so that there is at least six feet of clearance from all obstacles.
-

Warning The packing and binding straps are under extreme tension and could cause personal injury when cut. Exercise caution when cutting packing straps.

3. Carefully cut the packing straps.
 4. Pull the outer shipping box ① up and off the computer/shipping tray ② assembly. See Figure 3-5.
-

Note There is another strap holding the computer in a shipping tray, *DO NOT* cut that strap at this time. It will be removed later in the process.

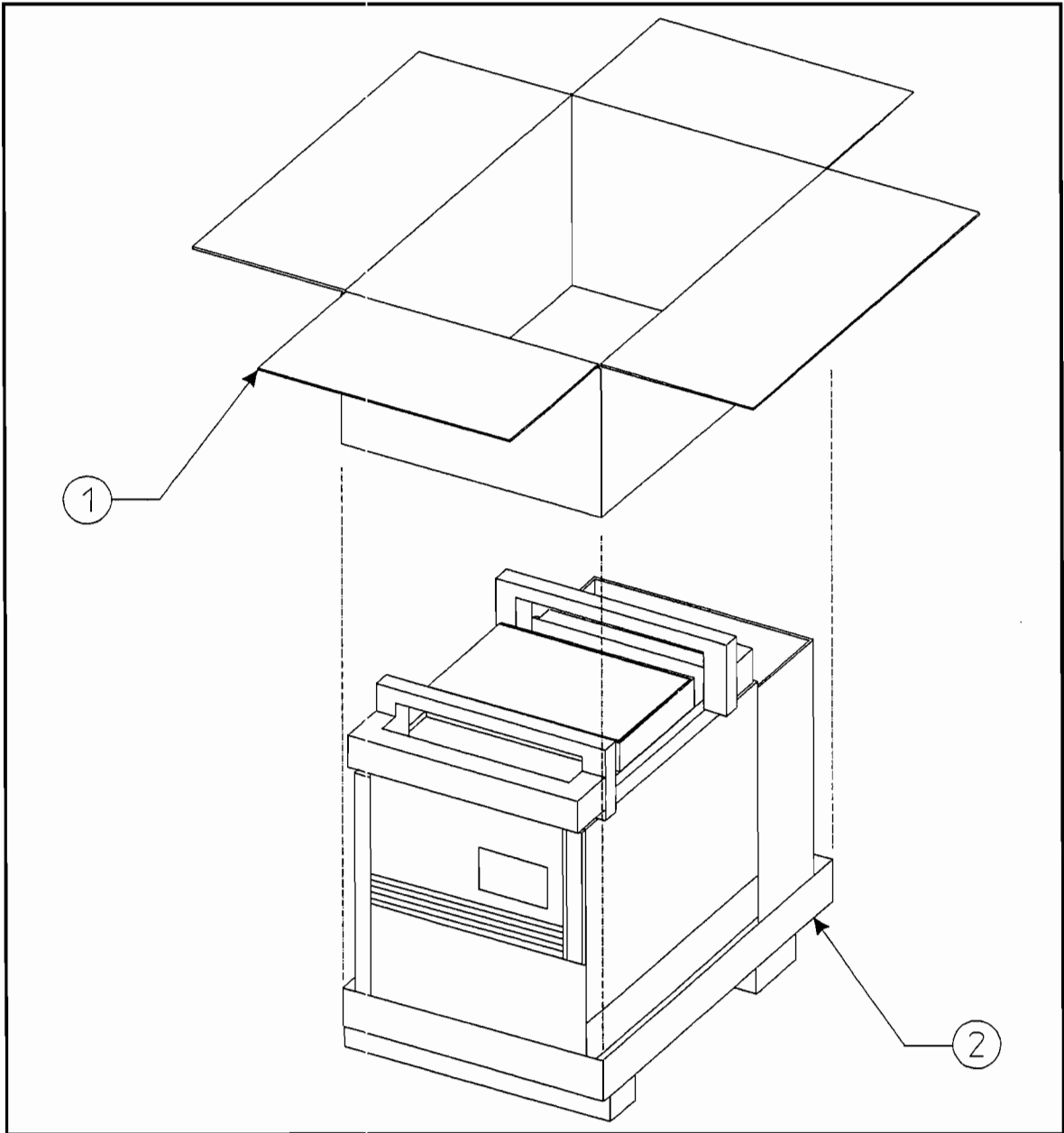

Figure 3-5. Removing the Outer Shipping Box

5. Remove the small accessory box ①, shipping foam ②, and accessories from the large accessory box ③. Remove the large accessory box ③. See Figure 3-6.

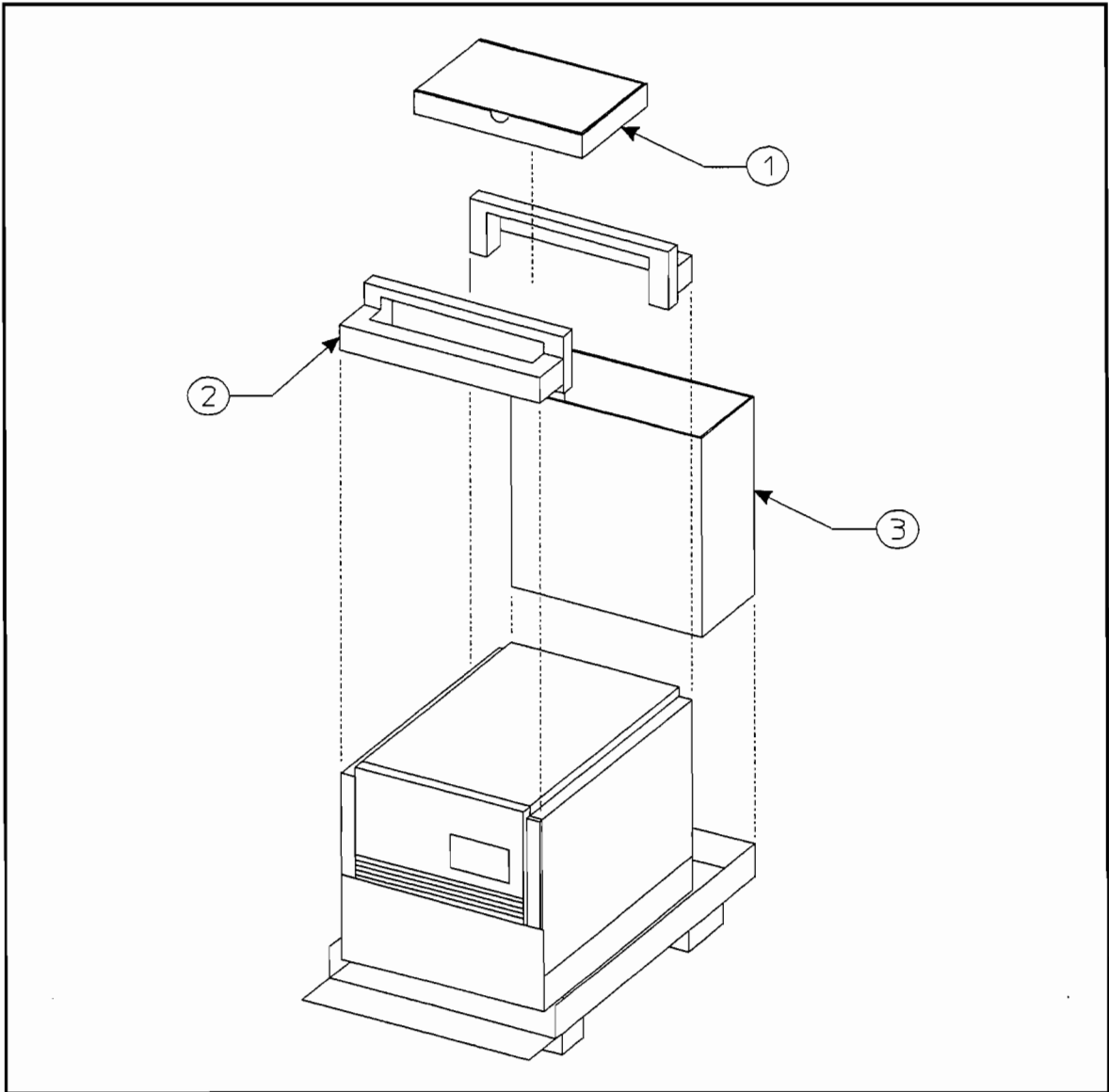

Figure 3-6. Unpacking the Accessories

6. Cut or tear the corners of the shipping box bottom that are adjacent to the front of the computer, as shown in Figure 3-6. Fold the flap, created by the cuts, down to form a small ramp.
7. Carefully slide the computer (still in its shipping tray) out of the shipping box bottom. The strap holding the computer to the shipping tray should still be in place.

Warning **The packing and binding straps are under extreme tension and could cause personal injury when cut. Exercise caution when cutting packing straps.**

8. Carefully cut the strap holding the computer to the shipping tray.

3-6 Receiving The System

9. Lower the shipping tray flap ① at the front of the computer. See Figure 3-7. This flap forms a ramp for removing the computer.

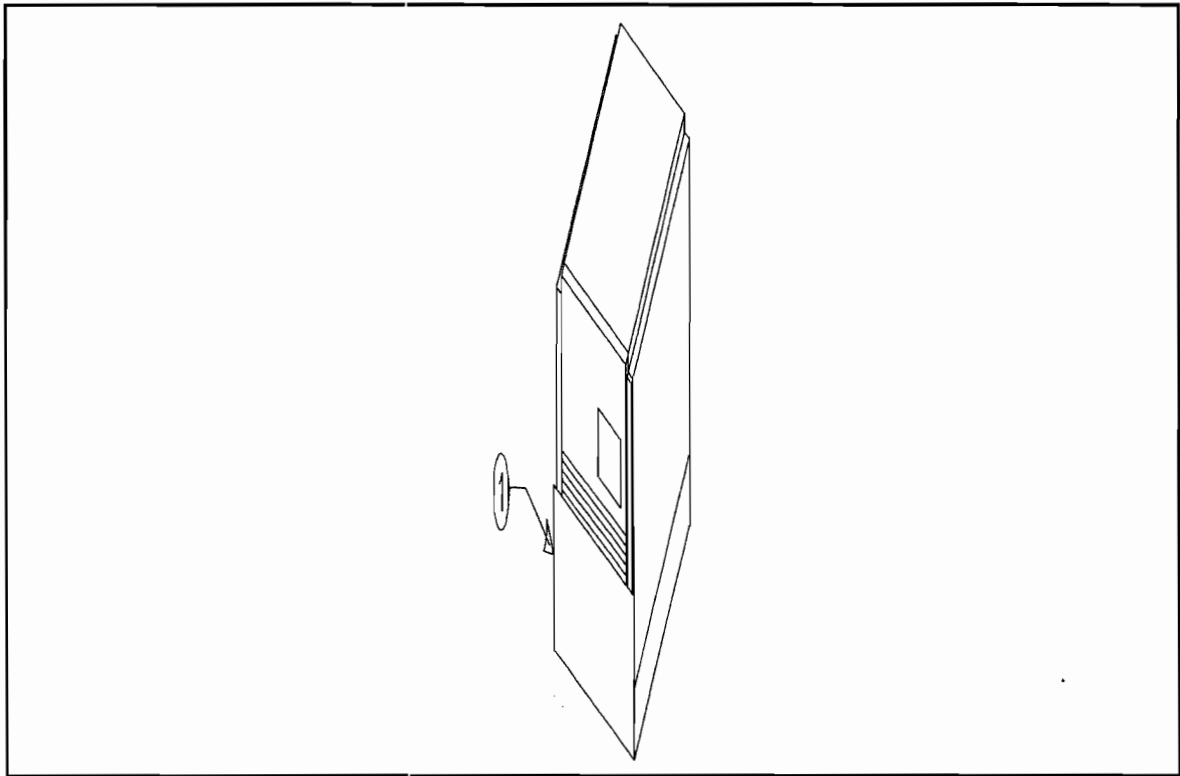

Figure 3-7. Lowering the Ramp

10. Carefully slide the computer down the ramp off the shipping tray.
11. Position the computer close to the final installation site. Leave enough room to access the back of the computer for installing any optional cards and cables.
12. Unpack any other components and peripherals of the computer system.

In Case of Damage

If damage is observed, refer to the claims Procedures section later in this chapter.

Physical Inventory

When the shipping containers is opened, locate the picklist which contains a list of equipment supplied. Compare the product and option numbers on the picklist with the purchase order to verify that the shipment is correct.

Manuals

Ensure that all of the manuals listed have been received. If any of the manuals are damaged or missing, refer to the Claims Procedure section.

Update the documentation as required before installing the computer. Update instructions are provided in a supplement supplied with each respective document.

Equipment

Ensure that all of the equipment on the list has been received. If any of the equipment is damaged or missing, refer to the Claims Procedures section.

Computer

Ensure that the model and serial numbers are identical to those specified on the picklist. The model and serial numbers are printed on a general information label, located on the back of the computer.

The computer comes with some peripherals embedded in the SPU cabinet. Check that these peripherals are integrated and that they match the equipment list. The general information label contains the serial numbers of the embedded peripherals, along with regulatory approvals and electrical ratings.

Claims Procedures

Notify the nearest Hewlett-Packard Sales and Service Office if the shipment is incomplete, damaged, or fails to meet specifications. If damage occurred in transit, notify the carrier as well.

Hewlett-Packard will arrange for replacement or repair without waiting for settlement of claims against the carrier. In the event of damage in transit, retain the packing container and packing materials for inspection.

Repacking

When computers must be reshipped, use the original shipping and packing materials, if available. Contact the local Hewlett-Packard Sales and Service Office for repacking information and materials.

Storage Requirements

Hewlett-Packard computer equipment can be stored or shipped in environments that fall within the following limits:

- Storage Temperature (with tape media): -40° to 45° C (-40° to 113° F)
- Storage Temperature (without tape media): -40° to 65° C (-40° to 149° F)
- Rate of change (with tape media): <10° C/hr.
- Rate of change (without tape media): <20° C/hr.
- Non-operating humidity; 5% to 80% non-condensing
- Humidity rate of change: <30% RH/hr.

Caution The computer and components should be protected from environmental extremes that can cause condensation within the equipment. When installing the equipment, allow time for the temperature of the equipment to stabilize to the site environment.





Installation

This chapter contains information for installing the HP 3000 Series 9X7 Family Computer systems. All installation tasks should be performed by trained and experienced personnel only. The installation tasks are as follows:

- System Processor Unit (SPU) Installation
- System Console Installation
- Datacommunication Terminal Controller (DTC) Installation

Installation Procedures

Tools required: Standard CE hand tool set, plus a #10 Torx driver.

SPU Installation

To install the SPU, perform the following steps:

1. Remove the I/O RFI covers from the slots that will hold any I/O cards to be installed. Table 4-1 is an example of the power consumption worksheet that must be completed before installing any additional I/O cards and peripherals to the system.

Note Refer to the *CE Handbook* (part number A1707-90016) for specific details on I/O card slot loading and configuration information.

2. Install all I/O cards into an appropriate I/O slot. Make a note of the type of card inserted into the I/O slot, as well as the slot number. This information will be used during system configuration.
3. Connect all external peripherals to the appropriate I/O connector at the back of the SPU.
 - a. The top connector on the multifunction I/O card is for SCSI peripherals. If there are no additional SCSI peripherals to connect, install a SCSI terminator (part number 1252-3932) to the SCSI connector.
 - b. Refer to the documentation that came with the peripheral device for specific installation instructions for that device.
 - c. Use only the cables that come with the peripheral device.

Note SCSI cable part numbers are listed in *Chapter 8* of the *CE Handbook*. *Chapter 4* of the *CE Handbook* has external SCSI cabling and configuration information.

- d. Make a note of all device addresses that apply to system configuration, along with the slot number that they are connected to. Refer to the note in step 1.
- e. Connect a BCN T connector to the **ThinLAN** connector on the Multifunction I/O card.

Note The **ThinLAN** connector is enabled at the factory, and the **AUI LAN** connector is disabled. If the **AUI LAN** connector needs to be enabled, the Multifunction I/O card has to be removed and jumper block W1 needs to be repositioned. Refer to the *CE Handbook, Chapter 4* for more configuration information.

Table 4-1. Example Power Consumption Worksheet

| Component | Left Bank | | | Right Bank | | |
|--------------------------------|-----------|-------|------|------------|------|------|
| | +12V | +5V | -12V | +12V | +5V | -12V |
| MULTIFUNCTION I/O CARD | | | | | | |
| | | | | | | |
| INTERNAL PERIPHERALS | | | | | | |
| Bay 1 | | | | | | |
| Bay 2 | | | | | | |
| Bay 3 | | | | | | |
| Bay 4 | | | | | | |
| Bay 5 | | | | | | |
| Bay 6 | | | | | | |
| I/O CARDS | | | | | | |
| Slot 1 | | | | | | |
| Slot 2 | | | | | | |
| Slot 3 | | | | | | |
| Slot 4 | | | | | | |
| Slot 5 | | | | | | |
| Slot 6 | | | | | | |
| Slot 7 | | | | | | |
| Slot 8 | | | | | | |
| Slot 9 | | | | | | |
| Slot 10 | | | | | | |
| Slot 11 | | | | | | |
| Slot 12 | | | | | | |
| TOTAL CURRENT REQUIRED | | | | | | |
| TOTAL CURRENT AVAILABLE | 6.27 | 27.00 | 1.50 | 6.27 | 6.80 | 1.50 |

System Console Installation

There are two types of consoles supported on the HP 3000 9X7 family of computers. One is the standard terminal type console used as the dedicated system console. The second is a 386-based OpenView PC, supplied with the necessary software to act as a system console, supported on the HP 3000 9X7RX/SX PLUS System.

Standard System Console

1. Connect the system console cable (part number A1703-63003) to the Multifunction I/O card connector labeled **Console**, on the rear of the SPU.
2. Connect the other end of the system console cable to the console connector labeled **DATACOMM.**, located on the back of the console. Refer to the documentation that came with the console for specific installation instructions that apply to the device being used as the system console.

PLUS System Console

1. Unpack the 386-based OpenView PC.
2. Follow all installation procedures described in the OpenView PC documentation.

Caution DO NOT connect the PC Monitor to the connector with the screen **ICON**, connect the PC monitor to the 9-pin D type connector in the expansion slots.

3. Connect the system console cable (part number A1703-63003) to the Multifunction I/O card connector labeled **Console**, on the rear of the SPU.
4. Connect the other end of the system console cable to the OpenView PC, RS-232 serial port on the rear. The serial port is a 25-pin, D type connector on a card in the PC expansion slots.

Caution DO NOT connect the console cable (A1703-63003) to the PC connectors labeled **SERIAL** on the back of the PC, connect it to the 25-pin D type connector in the expansion slots.

5. Connect a BNC T connector to the LAN connector on the OpenView PC.
6. Connect the ThinLAN cable to one side of the BNC connector. The other end of the ThinLAN cable connects to the SPU BNC T connector (ThinLAN).

DTC Installation

There may be multiple DTCs to be installed on the system. Repeat the installation instructions for each DTC installed on the system.

1. The DTC is connected to the SPU through the LAN link.
2. Connect another BNC T connector (part number 92227N) to the connector labeled **LAN Interface** on the back of the DTC.
3. Connect the LAN cable (all ready connect to the SPU, or the OpenView PC) to the DTC BNC T connector.

4. If there is another DTC, connect a LAN cable from the other end of the BNC T connector to the next DTC.
5. On the last DTC installed, connect a LAN terminator (part number 92227P) to the remaining side of the BNC T connector assembly.
6. Cover all the BNC T connector assemblies with the fabric anti-static cover that came with the T connector.
7. Refer to the documentation that came with the DTC for complete installation and configuration instructions.

Note Be sure that each end of the system LAN link has a BNC LAN Terminator (part number 92227P) installed.

Installation Completion

1. Make sure all (SPU and peripheral devices) power switches are in the OFF position.
2. Connect the SPU power cord (For RX and SX there are two power cords) to an ac outlet(s).
3. Connect all peripheral device power cords to ac outlets.

The computer system should now be ready for initial power up self-test, and system configuration. Continue to *Starting the Computer System* Chapter 5.

Starting the Computer System

The procedures listed in this chapter show you how to interact with the computer to get you to the ISL (Initial Software Load) prompt (ISL>_). When the ISL prompt is displayed, the command to load the MPE/iX operating system software can be issued.

Turning On the Computer System

The computer and its external equipment contain built in self-test programs. These programs automatically run each time the computer and the equipment are turned off and then turned on again.

Remember, depending on how much internal memory the computer has, the computer self-test can take up to approximately 2 to 5 minutes to complete.

Caution *Do not* move the computer or disk cabinet while the power is on. Moving the equipment while power is on can cause disk damage and loss of data.

Initial Power On

When turning on the computer system (this includes all equipment) be sure to follow the sequence listed below:

Caution If any of the external equipment has been OFF due to any environmental problem, such as heating or air conditioning failure, allow approximately 30 minutes for the temperature of the equipment to stabilize before turning on the computer.

1. Turn on all the external equipment (except the DTC) connected to the computer first.
2. Check all READY or ONLINE indicator lights on the external equipment to be sure that they indicate being powered up and ready.
3. For HP 3000 9X7RX/SX PLUS Systems, perform the following steps on the 386-based OpenView PC:
 - a. Turn on the OpenView PC and PC Monitor.
 - b. when the PC monitor displays the DOS prompt (C:\>), type *win* and press **Enter**. This starts the Windows program. The PC hard-disk has all the necessary software to come up in Windows with the console window (*Console ldev-20*) active (in the foreground).
 - c. If the console window is not in the foreground of the PC monitor, place the mouse arrow in the top bar of the window (with *Console ldev-20* written in it) and click the left mouse button once. This brings the console window into the foreground and makes it active. For information about using windows on the OpenView console, refer to the *HP OpenView Console User's Guide* (B3118-90001).
 - d. The console window and PC keyboard now act as a normal system console. All screen displays described in this chapter are displayed in the console window as shown.
 - e. To make the console window the largest size possible, place the mouse arrow in the upper right corner on the up arrow (▲) and click the left mouse button once.
4. When all external equipment indicate READY or ONLINE by their particular indicator lights, press the computer ON/OFF switch to the ON position.

To identify the computer's first displays

The primary display for the computer is the system console, or the *Console ldev-20* window on the 386-based OpenView PC.

1. The first thing displayed on the computer console is a line of messages along the bottom of the console screen indicating the self-test programs are running:

```
TEST nnnn REMOTE: disabled inactive multiple ACCESS FAULT: yy
```

2. When self-test is complete, the console displays a screen similar to the following:

```
Processor Dependent Code (PDC) revision x.x

Console path      = 56.0.0.0.0.0.0 (dec)
                  38.0.0.0.0.0.0 (hex)

Primary boot path = 52.6.0.0.0.0.0 (dec)
                  34.00000006.0.0.0.0.0 (hex)

Alternate boot path = 52.0.0.0.0.0.0 (dec)
                   34.0.0.0.0.0.0 (hex)

nn MB of memory configured and tested.
```

The revision number *x.x* and amount of memory *nn* will vary depending on when the computer is purchased and how much memory was ordered. The values for the paths may differ slightly from this display.

3. When the console display resembles step 2, the following conditions should be true:
- the console display should not end with any error messages.
 - the tape drive indicator lights should both be OFF.
4. If the conditions in step 3 are true, proceed with the rest of the computer start up procedures.
5. If any of the conditions in step 3 are wrong, refer to the *CE Handbook* for troubleshooting procedures.
6. Next the computer asks if you want to boot from the primary boot path.
- Type Y and press the **Return** key, as shown:

```
Boot from primary boot path (Y or N)?> Y Return
```

7. Next the computer asks if you want to interact with Initial Program Load (IPL) software.
- Type Y and press the **Return** key, as shown:

```
Interact with IPL (Y or N)?> Y Return
```

- The computer now starts the process of loading the IPL software from the internal disk drive, to the computer memory.

There are a number of things displayed on the computer console, as shown:

```

Alternate boot path   = 52.0.0.0.0.0.0 (dec)
                      34.0.0.0.0.0.0 (hex)

nn MB of memory configured and tested.

Boot from primary boot path (Y or N)?> Y

Interact with IPL (Y or N)?> Y

Booting. . .
Boot path initialized.
Attempting to load IPL.

HARD Booted

ISL Revision x.xx.xx DATE

ISL>

```

The word *Booting* appears while the computer is booting. The next three messages display as the load process continues. The *x.xx.xx* is an Initial System Load (ISL) revision number and will vary with the release and date of the product.

- At this point the ISL prompt (ISL>) is displayed. The system should be waiting for your response to the ISL> prompt.
- Respond to the ISL> prompt with one of the following commands, depending on how many disk drives the system has. Check the customer's order to determine how many disk drives were ordered in the SPU.

Table 5-1. START with 1, 2, 3, or 4 Disk Drives

| TOTAL Disk Drives (from Worksheet) | Use the Appropriate Command |
|------------------------------------|---|
| 1 | START <input type="button" value="Return"/> |
| 2 | START GROUP=CONF9X72 NORECOVERY <input type="button" value="Return"/> |
| 3 | START GROUP=CONF9X73 NORECOVERY <input type="button" value="Return"/> |
| 4 | START GROUP=CONF9X74 NORECOVERY <input type="button" value="Return"/> |

5-4 Starting the Computer System

For example, an HP 3000 Series 947SX model with a total of two disk drives (2 internal disk drives) would use the following command:

```
ISL> START GROUP=CONF9X72 NORECOVERY 
```

11. After a few minutes, you are prompted to confirm the date and time as shown below. *If you do not respond within 15 seconds, the system accepts the displayed date and time by default, and continues with the start-up process.*

- If the date and time displayed are accurate, type Y and press , or wait for the time out.
- If they are not, type N and press within the 15 seconds allowed.

Enter the correct date and time when prompted. Time must be entered in 24-hour format (for example, 5:00 p.m. is entered as 17:00). Seconds default to 00 if not specified.

```
MPE/iX launch facility
Initialize_genesis - Version : <<870204.1552>>
TUE, AUG 11, 1991, 10:20:03 AM (y/n)? Y

[TMUX_DAM] n n n n
Initialize genesis completed.
```

The fundamental operating software is starting.

If you have used one of the commands that included the phrase NORECOVERY, warning messages will be displayed on the console telling you that unconfigured devices are attached to the system. These messages are normal during the first boot up. They appear during the first boot up because the final configuration is not done. Among the messages you may see are these:

```
DCC warning 103-5, Add ldev to class failure (HLIO status FF6A00BD,..
DCC warning 103-5, Add ldev to class failure (HLIO status FF6A00BD,..
DCC STARTUP - ERROR
```

The system is making many internal checks and is reporting that the configuration is not complete. When this checking process is complete a welcome message is displayed on the console. You are automatically logged on to the system as OPERATOR.SYS.

12. When the system prompt (:) is displayed, all the system self-tests are complete. At this time, turn on the DTC(s). The configuration process can begin. For configuration procedures on the OpenView PC, refer to the *HP OpenView Console Manager's Guide* (B3118-90002).

Installation Verification

Once the configuration is complete, the system installation can be verified by the use of the *Verifier* program.

The Verifier program usually resides in the DIAG group of the SYS account. However, a command file named VERIFY.PUB.SYS is provided to setup the proper environment for Verifier operation.

To invoke MPE/iX Verifier log on as Manager.Sys (or any log on with SM, OP or DI capability) and enter the following:

VERIFY

Follow the program prompts on the console screen. Verifier performs more than one task at one time. For this reason, you will frequently see messages for assorted devices interspersed with one another, this is normal.

Verifier global status messages

When Verify is finished it prints one of three status messages indicating:

If everything verified as *okay* a message similar to the following appears:

```
System verification is complete. Everything is okay.  
Proceed with the next operation...
```

If something needs *attention*, a message similar to the following appears:

```
ATTENTION: System verification indicates that noncritical  
devices are not all working.
```

This message indicates a problem with a *noncritical* device. A noncritical device is everything *except*: system disks, nonsystem (private volume) disks and tape drive logical device 7.

If there is an *error*, a message similar to the following appears:

```
ERROR: System verification failed. Critical devices are  
not functional. Do not continue to use the system.
```

This message indicates a *critical* device failed. You should not attempt to use the system until the problem has been corrected. *Critical* devices are all system disks, all non-system (private volume) disks and tape drive logical device 7.

Verifier log file

In addition to the messages described above, MPE/iX Verifier creates a log file named VERLOG. This file contains a detailed history of the verification actions and status messages and a system I/O map which shows the current status of each device and the overall system status.

VERLOG is created in the group and account from which Verifier is invoked. However, a file equation can be used to redirect it to another location.



Remote Support Modem Configuration

This section contains information for connecting specific modems to the HP 3000 9X7 Family Computer System. This section also discusses the signal line behavior of the Multifunction I/O modem interface to aid in configuring modems that are not listed.

General rules for configuring modems:

- The modem must be set up to respond to DTR.
- CTS should follow RTS.
- DSR must follow OH, not DCD.
- For Bell mode, the modem should disregard RTS.
- Set both local and remote modems to either:
 - the same compression mode, OR
 - to NO data compression.



If problems occur connecting two modems, usually the fault is that one is enabled for some MNP level and the other modem is set for no data compression.

If the modem sends up-modem dialog with all of the signals asserted, it is possible for the user to be logged off immediately when a password is enabled for the Access Port. This can be corrected by setting the modem so it does not report connection status via the data path.

Note V.22bis/V.25bis modes are not supported on the A1703-60004 or A1703-60022 Multifunction I/O interfaces.

Quick Reference

Table A-1 is a quick reference table for the supported modems for remote support. For detailed information, refer to the appropriate section of this appendix.

Table A-1. Settings for Remote Support Modem (Quick Reference)

| Modem Model | Settings |
|-------------------------------|--|
| HP50759A (Support Link) | X1, X2, X3, X4, and S8: Down S1, S3, S4, S5, and S6: Up S2 and S7: Do not care |
| Hayes Smartmodem 2400 | S3, S9, and S10: Down S1, S4, S5, S6, and S7: Up S2: Do not care |
| Black Box V.32 Plus (2.01.01) | AT&D2&S1&C1&R (See Black Box V.32 section for details) |
| Multitech MT224EH7 | X1, X4, S3, S7, and S8: Down X2, X3, S1, S2, S4, S5, and S6: Up |
| HP 37212B | S1, S2, S4, S5, S6, S7, and S10: Down (0) S3, S8, S9, S11, and S12: Up (1) |

HP Support Link (HP50759A)

Supported modes:

- Bell
- CCITT_OM
- CCITT_AM
- CCITT_BIS_OM
- CCITT_BIS_AM

Supported cables:

- HP 92219Q - Bell, CCITT_OM, CCITT_AM
- A1703-63006 - CCITT_BIS_OM, CCITT_BIS_AM

Auto-dial modes: Hayes

This modem is the standard HP Support Link. It supports V.22bis line discipline, but does not support V.25bis auto-dialing. In order for V.22bis answer mode to work properly, DSR must follow OH. Data Compression should be set *OFF*. Setting data compression *ON* can cause problems when connecting to other modems that do not have data compression.

Table A-2. 8-Position DIP Switch Option Settings (Set S)

| Switch | Position | Description | Option Command |
|--------|----------|-------------------------|----------------|
| S1 | up | DTR Normal | &D2 |
| S2 | xx | Verbose Responses | V1 |
| S3 | up | Suppress Responses | &Q0 |
| S4 | up | Enable Echo of commands | E1 |
| S5 | up | Enable Auto-Answer | S0=1 |
| S6 | up | DCD/DSR Normal | &C1 &S1 |
| S7 | xx | Depends on phone line | |
| S8 | down | Enable Command Mode | |

Note xx means do not care.

Table A-3. 4-Position DIP Switch Option Settings (Set X)

| Switch | Position | Description | Option Command |
|--------|----------|-------------------|---------------------------------|
| X1 | down | CTS Normal | &R0 |
| X2 | down | DSR Follows OH | &S1 |
| X3 | down | Use HP Defaults | &E0 &E3 &E6 &E8 &E10 &E14 \$BA1 |
| X4 | down | No ENQ/ACK Pacing | &E8 |

Note An AT1517 command should have the following output:

```
BO E1 M1 Q0 V1 X0 &EO &E3 &E6 &E8 &E10 &E14 &Q0
$MB2400 $SB2400 $BA1 &W1

&AO $AO &BO &BS1 &C1 &D2 $DO $F1 &GO &IO &MO $MIO &RO $RO &S1 &T5
&V1 &W1

OK
```

Hayes Smartmodem 2400

Supported modes:

- Bell
- CCITT_OM
- CCITT_AM

Supported cables:

- Must use 92219Q modem cable.

Auto-dial modes: Hayes.

This modem drives circuit 111 (Pin 23) instead of using it as an input. With either cable (92219Q or A1703-63006), the Multifunction I/O PCA and the modem, drive the same line.

Caution This modem should not be used because all HP cables connect circuit 111 to the modem. If this modem is connected, both the Multifunction I/O PCA and the modem drive circuit 111. This modem has been used in the past with the CIO based AP card and had the same problem.

Turn off all data compression modes.

The Hayes defaults for the modem lines must be changed to the following:

Table A-4. Switch Option Settings

| Switch | Position | Description | Option Command |
|--------|----------|-------------------------|----------------|
| S1 | up | DTR normal | AT&D3&W |
| S2 | xx | | |
| S3 | down | Result codes disabled | ATQ1&W |
| S4 | up | Characters echoed | ATE1&W |
| S5 | up | Auto-Answer enabled | ATS0=1&W |
| S6 | up | Detect Carrier | AT&C1&S1&W |
| S7 | up | RJ-11 | AT&J0&W |
| S9 | down | CCITT | ATB0&W |
| S10 | down | Return to command state | AT&D3&W |

Note xx means do not care.

Black Box V.32 Plus (Version 2.01.01)

Supported modes:

- Bell
- CCITT_OM
- CCITT_AM

Supported cables:

- Must use 92219Q modem cable.

Auto-dial modes: Hayes.

This modem does not work with v.22bis because it does not supply 112 and because the sense of 111 is backwards (TRUE means low speed, FALSE means high speed). The fact that 111 is backwards is not too big a problem because the modem can be configured to ignore 111. Change so that DTE Fallback is *Disabled*. This is the factory default. Not supplying 112 means that the Multifunction I/O PCA always thinks it is running at the lower speed. If you set the speed for twice the desired speed, then it will work at the desired speed. It is best not to use this modem with any of the CCITT bis protocols.

The Black Box defaults for all of the modem lines are incorrect and must be changed before this modem will work properly. To do this from the front panel, go into the Change DTE Parameters and set the following:

Responds to DTR
DSR is Normal
DCD is Normal
CTS follows RTS

This can be done with the following AT command: `AT&D2&S1&C1&R`

For Hayes dialing, make certain that the AT command set is enabled. It is normally good to disable status messages to the host by using the `ATQ1` command.

The current configuration can become the power-on configuration by using the `AT&W` command.

This modem does not do any rate shifting. So the DTE rate and the DCE rate must be the same.

This modem seems to work in AP mode with the protocol set to either Bell or CCITT. It does not work with the modem protocol set to CCITT_BIS. Make certain to configure the modem to ignore 111, or configure the Access Port to set FS low. It also seems to work fine in normal mode (i.e. under host control).

Multitech MT224EH7

Supported modes:

- Bell
- CCITT_OM
- CCITT_AM
- CCITT_BIS_OM
- CCITT_BIS_AM

Supported cables:

- HP 92219Q - Bell, CCITT_OM, CCITT_AM
- A1703-64006 - CCITT_BIS_OM, CCITT_BIS_AM

Auto-dial modes: Hayes, V.25bis.

Note The version of the modem has a problem when dialing with V.25bis where if the number that is dialed is busy, DSR does not drop. This same problem causes V.25bis error indications to be improperly decoded, meaning that the modem time-out timer must expire before we know that the attempt failed. This also means that multiple dialing attempt will always fail. If the DSR jumper is set so that DSR follows DCD, this problem goes away.

The configuration of the hardware switches on the modem are:

8-position DIP-Switch (S switches):

| | | | | | | | | |
|---------|----|----|------|----|----|----|------|------|
| Switch: | 1 | 2 | 3 | 4 | 5 | 6 | 7 | 8 |
| ----- | | | | | | | | |
| | UP | UP | DOWN | UP | UP | UP | DOWN | DOWN |

4-position DIP-Switch (X switches):

| | | | | |
|---------|------|----|----|------|
| Switch: | 1 | 2 | 3 | 4 |
| ----- | | | | |
| | DOWN | UP | UP | DOWN |

For Hayes mode to work correctly, AT&R0 must be set so that it drops CTS when the connection goes down. For Hayes, AT\$V0 must be set. For V.25bis dialing, VT\$V1 and AT\$BA1 must be set.

Hayes dialing parameters:

```
BO E1 M1 Q0 RO V1 XO &E1 &E4 &E6 &E8 &E10 &E13 &E15
$MB2400 $SB2400 $BA1 &W0

S0 S2 S3 S4 S5 S6 S7 S8 S9 S10 S11 S12 S24 S25 S30
001 043 013 010 008 002 030 002 006 007 070 050 020 000 000

$A0 &A0 &B0 &BS1 &C1 $D0 &D2 #DB0 $EBO $F1 &GO #LO $MIO &MO
&PO #P2 &Q0 &Q3 $RO &R1 &S1 $T1 &T4 $VO $VDO &XO YO
$MB2400 $SB2400 $BA1 &W0
```

OK

For V.22bis auto-answer, internal jumper DSR must be set so that DSR follows OH. The factory default is for DSR to follow CD. This is different from the Support Link where the factory default was for DSR to follow OH. There does not seem to be an AT command that does this.

V.25bis dialing parameters:

```
BO E1 M1 QO RO V1 XO &E1 &E4 &E6 &E8 &E10 &E13 &E15
$MB2400 $SB2400 $BA1 &WO
```

```
S0 S2 S3 S4 S5 S6 S7 S8 S9 S10 S11 S12 S24 S25 S30
001 043 013 010 008 002 030 002 006 007 070 050 020 000 000
```

```
$AO &AO &BO &BS1 &C1 $DO &D2 #DBO $EBO $F1 &GO #LO $MIO &MO
&PO #P2 &QO &Q3 $RO &R1 &S1 $T1 &T4 $V1 $VDO &XO YO
$MB2400 $SB2400 $BA1 &WO
VAL
```

To modify a MT224E7B:

- Open modem and change the DSR jumper.
- Set switches on the bottom of the box to above.
- Send AT&R0
- For Hayes dialing, send AT\$V0.
- For V.25bis dialing, send AT\$V1.

HP 37212B

Supported modes:

- Bell
- CCITT_OM
- CCITT_AM
- CCITT_BIS_OM
- CCITT_BIS_AM

Supported cables:

- HP 92219Q - Bell, CCITT_OM, CCITT_AM
- A1703-64006 - CCITT_BIS_OM, CCITT_BIS_AM

Auto-dial modes: None

It is best to use this modem in CCITT mode because it causes the Access Port to hang up if used in Bell mode at 1200 baud. It can be used in Bell mode at 2400 baud, or either 1200 or 2400 in CCITT mode. This modem can not be dialed with either Hayes or V.25BIS auto-dial protocols. Table A-5 describes the switch settings.

Table A-5. HP 37212B Switch Configuration

| Switch | Position | Description |
|--------|----------|--|
| S1 | down | Computer mode operation (HP command set) |
| S2 | down | |
| S3 | up | |
| S4 | down | Primary channel |
| S5 | down | 1 start, 8 data and 1 stop |
| S6 | down | |
| S7 | down | Error correction disabled |
| S8 | up | No Flow control |
| S9 | up | |
| S10 | down | DSR/CTS/CD to RS-232-C definition |
| S11 | up | |
| S12 | up | DTR behaves to RS-232-C definition |

Note Although this modem claims to be able to dial using V.25bis, it only uses the V.25bis line discipline. The command set does not match the set specified in the V.25bis specification.

Modem Cable Pin-out

Table A-6 list the pin-outs for the 92219Q cable, which is most often used to connect the Access Port to the support modem.

Table A-6. 92219Q Cable Pin-out

| Computer End | Signal Name | Modem End |
|--------------|-------------|-----------|
| 2 | TD | 3 |
| 3 | RD | 2 |
| 8 | RTS | 4 |
| 22 | CTS | 5 |
| 20 | DSR | 6 |
| 6 | DTR | 20 |
| 9 | RI | 22 |
| 4 and 5 | DCD | 8 |
| 23 | FS | 23 |
| 7 | GROUND | 7 |

The pin-out for the A1703-63006 cable is the same except that pin 9 on the computer end is routed to pin 12 on the modem end and that Line functions as Rate Select (RS). This cable is only used with the A1703-60003 SCSI/Console/LAN Multifunction I/O interface for V.22bis/V.25bis applications.

Multifunction I/O PCA Modem Line Behavior

CCITT Mode AP protocol 0

This protocol is known as HP-UX CCITT. The card waits for RI before raising DTR. It also raises RTS when it raises DTR. If DSR does not come up within 25 seconds, DTR goes back down. The connection also depends on CTS and DCD. DCD can drop for up to 400ms before the connection will drop. CTS must stay high always. Once CTS drops, the connection starts to drop. A new connection cannot occur until DSR, DCD and CTS all drop. FS can be programmed to either state via the CA command.

Bell Mode AP protocol 1

This is sometimes called Bell simple protocol. It raises DTR when it can accept a connection. The connection is valid when it sees DCD. It drives RTS whatever it was when Remote is enabled (usually, RTS is low) and does not look at DSR or CTS. When a disconnect is done, DCD must drop before a new connection can be made (i.e. it will not raise DTR until DCD drops).

CCITT_BIS Mode AP protocol 2

This protocol is CCITT V.22bis. It requires the special cable A1703-63006 which is just like the 92219Q cable with the exception that pin 9 on the computer end is routed to pin 12 (RS) rather than pin 22 (RI). DTR is raised whenever a connection is allowed. RTS follows DSR. A connection is established when DSR is high. CTS can drop for an indefinite amount of time without dropping the connection. The card will not send data to the modem when CTS is low. DCD can drop for up to 400ms before the connection is dropped. Once the connection is dropped, DSR, DCD and CTS must all go low before a new connection can be made. RS controls what speed the card sends to the modem. If RS is high, the programmed baud rate is used. If RS is low, half of the programmed baud rate is used. If you use the 92219Q cable, the baud rate will most certainly be half the programmed baud rate, since RI will almost always be down. FS can be programmed to either state via the CA command.

Modem Settings (Predictive Support)

The *MPE/iX Predictive Support Handbook* contains additional information on predictive support modem settings. Table A-7 contains a quick reference description of the modem switch settings.

| | |
|-------------|--|
| Note | Some of the settings in Table A-7 are different than those described in the first part of the Appendix. Also be aware that the modems listed here are not necessarily recommended or supported as Remote Support Modems. |
|-------------|--|

Table A-7. Predictive Support Modems and Switch Settings

| Modem Type | Switch Settings |
|--------------------------|--|
| HP 50759A (Support Link) | X1, X2, X4, S4, and S8; Down All others; Up |
| HP 37212A | All switches; Open |
| Hayes Smartmodem | S4, S8, and S10; Down |
| Support Link I | Option 1: Code 3 Option 1: Code 2 Option 8: Code 2 Option 15: Code 2 Option 16: Code 2 Option 22: Code 1 for pulse Option 22: Code 2 for tone Option 22: Code 3 for autoselect Option 24: Code 2 |
| Support link II | Option 1: Code 3 Option 1: Code 2 Option 8: Code 2 Option 15: Code 2 Option 16: Code 2 Option 22: Code 1 for autoselect Option 22: Code 2 for tone Option 22: Code 3 for pulse |



READER COMMENT SHEET

Systems Technology Division

HP 3000 Series 9x7 Computer Systems
Installation and Configuration Guide

Manual Part Number A1707-92018 August 1993

A reader comment sheet helps us to improve the readability and accuracy of the document. It is also a vehicle for recommending enhancements to the product or manual. Please use it to suggest improvements.

SERIOUS ERRORS, such as technical inaccuracies that may render a program or a hardware device inoperative, should be reported to your HP Response Center or directly to a Support Engineer. An engineer will enter the problem on HP's STARS (Software Tracking and Reporting System). This will ensure that critical and serious problems receive appropriate attention as soon as possible.

Editorial suggestions (please include page numbers): _____

Recommended Improvements (attach additional information, if needed): _____

_____  _____

Name: _____ Date: _____

Job Title: _____ Phone: _____

Company: _____

Address: _____

HP 3000 Series _____ (eg., 922, 932, 925, 935, 950, 955, 960, 990, etc.)

HP 9000 Series _____ (eg., 808, 815, 825, 835, 845, 850, 855, 890, etc.)

Check here if you would like a reply.

Hewlett-Packard has the right to use submitted suggestions without obligation, with all such ideas becoming property of Hewlett-Packard.

Fold and Tape



NO POSTAGE
NECESSARY
IF MAILED
IN THE
UNITED STATES

BUSINESS REPLY MAIL

FIRST CLASS PERMIT NO. 1070, CUPERTINO, CA

– POSTAGE WILL BE PAID BY ADDRESSEE –

Publications Manager – Hardware
Hewlett-Packard Company
Systems Technology Division
19483 Pruneridge Avenue
Mailstop 42UK
Cupertino, California 95014-9786

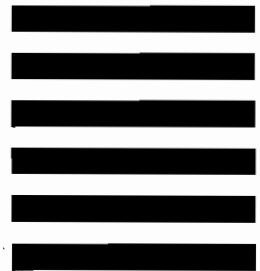

Fold and Tape

READER COMMENT SHEET

Systems Technology Division

HP 3000 Series 9x7 Computer Systems
Installation and Configuration Guide

Manual Part Number A1707-92018 August 1993

A reader comment sheet helps us to improve the readability and accuracy of the document. It is also a vehicle for recommending enhancements to the product or manual. Please use it to suggest improvements.

SERIOUS ERRORS, such as technical inaccuracies that may render a program or a hardware device inoperative, should be reported to your HP Response Center or directly to a Support Engineer. An engineer will enter the problem on HP's STARS (Software Tracking and Reporting System). This will ensure that critical and serious problems receive appropriate attention as soon as possible.

Editorial suggestions (please include page numbers): _____

Recommended improvements (attach additional information, if needed): _____

Name: _____ Date: _____

Job Title: _____ Phone: _____

Company: _____

Address: _____

HP 3000 Series _____ (eg., 922, 932, 925, 935, 950, 955, 960, 990, etc.)

HP 9000 Series _____ (eg., 808, 815, 825, 835, 845, 850, 855, 890, etc.)

Check here if you would like a reply.

Hewlett-Packard has the right to use submitted suggestions without obligation, with all such ideas becoming property of Hewlett-Packard.

Fold and Tape



NO POSTAGE
NECESSARY
IF MAILED
IN THE
UNITED STATES

BUSINESS REPLY MAIL

FIRST CLASS PERMIT NO. 1070, CUPERTINO, CA

– POSTAGE WILL BE PAID BY ADDRESSEE –

Publications Manager – Hardware
Hewlett-Packard Company
Systems Technology Division
19483 Pruneridge Avenue
Mailstop 42UK
Cupertino, California 95014-9786

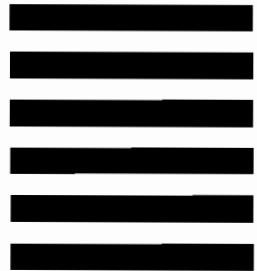

Fold and Tape

READER COMMENT SHEET

Systems Technology Division

HP 3000 Series 9x7 Computer Systems
Installation and Configuration Guide

Manual Part Number A1707-92018 August 1993

A reader comment sheet helps us to improve the readability and accuracy of the document. It is also a vehicle for recommending enhancements to the product or manual. Please use it to suggest improvements.

SERIOUS ERRORS, such as technical inaccuracies that may render a program or a hardware device inoperative, should be reported to your HP Response Center or directly to a Support Engineer. An engineer will enter the problem on HP's STARS (Software Tracking and Reporting System). This will ensure that critical and serious problems receive appropriate attention as soon as possible.

Editorial suggestions (please include page numbers): _____

Recommended improvements (attach additional information, if needed): _____

Name: _____ **Date:** _____

Job Title: _____ **Phone:** _____

Company: _____

Address: _____

HP 3000 Series _____ (eg., 922, 932, 925, 935, 950, 955, 960, 990, etc.)

HP 9000 Series _____ (eg., 808, 815, 825, 835, 845, 850, 855, 890, etc.)

Check here if you would like a reply.

Hewlett-Packard has the right to use submitted suggestions without obligation, with all such ideas becoming property of Hewlett-Packard.

Fold and Tape



NO POSTAGE
NECESSARY
IF MAILED
IN THE
UNITED STATES

BUSINESS REPLY MAIL

FIRST CLASS PERMIT NO. 1070, CUPERTINO, CA

- POSTAGE WILL BE PAID BY ADDRESSEE -

Publications Manager – Hardware
Hewlett-Packard Company
Systems Technology Division
19483 Pruneridge Avenue
Mailstop 42UK
Cupertino, California 95014-9786

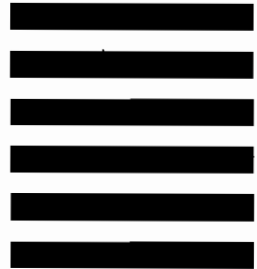

Fold and Tape