

# HP 2688A OPERATOR'S MANUAL

Manual Part No. 26088-90901

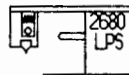

Text printed in U.S.A.  
on an  
HP 2680A Laser Printing System

**HP Computer Museum**  
**[www.hpmuseum.net](http://www.hpmuseum.net)**

**For research and education purposes only.**

# Publication History

Changes in text to document updates subsequent to the initial release are supplied in manual update notices and/or complete revisions to the manual. The history of any changes to this edition of the manual is given below. The last update itemized reflects the machine configuration documented in the manual.

Any changed pages supplied in an update package are identified by an update number adjacent to the page number. Changed information is specifically identified by a vertical line (revision bar) on the outer margin of the page.

First Edition .....OCT 1983

## NOTICE

The information contained in this document is subject to change without notice.

HEWLETT-PACKARD MAKES NO WARRANTY OF ANY KIND WITH REGARD TO THIS MATERIAL, INCLUDING, BUT NOT LIMITED TO, THE IMPLIED WARRANTIES OF MERCHANTABILITY AND FITNESS FOR A PARTICULAR PURPOSE. Hewlett-Packard shall not be liable for errors contained herein or for incidental or consequential damages in connection with the furnishing, performance, or use of this material.

This document contains proprietary information which is protected by copyright. All rights are reserved. No part of this document may be photocopied or reproduced without the prior written consent of Hewlett-Packard Company.

# 2688A

## TABLE OF CONTENTS

<b>SECTION I. GENERAL INFORMATION</b>	<b>PAGE</b>
Introduction-----	1-1
Product Description-----	1-1
Options-----	1-2
Location Considerations-----	1-2
Environmental Conditions-----	1-2
Mounting-----	1-3
Power Source-----	1-3
Printer Positioning-----	1-4
Minimum Clearance Requirements-----	1-5
Cautions in Relocation-----	1-5
Useful Information-----	1-5
Specifications-----	1-5
Supplies and Accessories-----	1-9
Operator Safety-----	1-10
<b>SECTION II. CONTROLS AND INDICATORS</b>	
Introduction-----	2-1
Functional Description of Printer Components-----	2-2
Printer Operator Guide Panel Description-----	2-3
HP 26088A Controller Description-----	2-4
Power Controls-----	2-5
<b>SECTION III. PREPARING THE PRINTER FOR USE</b>	
Introduction-----	3-1
Getting Your Printer Ready For Operation-----	3-1
Paper Loading-----	3-4
How to Add Paper-----	3-4
How to Change Paper Size-----	3-7
Adding Toner-----	3-7
Setting the HP-IB address-----	3-10
<b>SECTION IV. OPERATOR PREVENTIVE MAINTENANCE</b>	
Introduction-----	4-1
Corona Cleaning-----	4-1
Disposal Bottle Replacement-----	4-5
Fuser Cleaning Pad Replacement-----	4-7
Ozone Filter Replacement-----	4-11
OPC Belt Replacement-----	4-13
Sensor and Second Cylindrical Lens Cleaning-----	4-20

# 2688A

## SECTION V. IN CASE OF DIFFICULTY

## PAGE

Introduction-----	5-1
Paper Jams-----	5-1
Service Required Indicator-----	5-12
Operator Hints-----	5-13
Self Test-----	5-15
Reset-----	5-17

## LIST OF ILLUSTRATIONS

1-1. Installing Your HP 2688A-----	1-3
1-2. Front View-----	1-4
1-3. Side View-----	1-4
1-4. Minimum Clearance Requirements-----	1-5
1-5. Paper Size Image Area (8 1/2 x 11 in. paper)-----	1-7
1-6. Paper Size Image Area (A4 paper)-----	1-8
1-7. Safety Labels-----	1-11
1-8. Conformance Labels-----	1-11
2-1. HP 2688A Laser Page Printer-----	2-2
2-2. Printer Operator Guide Panel-----	2-3
2-3. HP 26088A Controller-----	2-4
2-4. HP 26088A Controller Rear Panel Description-----	2-4
2-5. Power ON/OFF Switches-----	2-5
3-1. Positioning the Printer-----	3-2
3-2. Connecting Printer's Power Cord-----	3-2
3-3. Connecting Controller's AC Power Cord-----	3-3
3-4. Connecting Video Cable-----	3-3
3-5. Connecting HP-IB Cable-----	3-4
3-6. Paper Cover-----	3-5
3-7. Adding Paper-----	3-6
3-8. Limit Line Location-----	3-6
3-9. Paper Guide Positioning-----	3-7
3-10. Pulling Out Development Drawer-----	3-8
3-11. Opening Toner Inlet Cover-----	3-9
3-12. Pouring Toner-----	3-9
3-13. Setting the HP-IB Address-----	3-10
4-1. Opening Left Cover-----	4-2
4-2. Removing Charge Corona-----	4-2
4-3. Cleaning the Charge Corona-----	4-3
4-4. Opening Development Drawer-----	4-4
4-5. Removing Transfer Corona-----	4-4
4-6. Cleaning Transfer Corona-----	4-5
4-7. Opening Left Side Cover-----	4-6
4-8. Removing Disposal Bottle-----	4-7
4-9. Pulling Out Paper Exit Unit-----	4-8
4-10. Opening Paper Exit Cover-----	4-8
4-11. Opening Upper Cover-----	4-9
4-12. Covering Upper Cover With Paper-----	4-10

## LIST OF ILLUSTRATIONS CONTINUED

## PAGE

4-13. Replacing Fuser Cleaning Pad Assembly-----	4-10
4-14. Cleaning Oil-Spreading Roller-----	4-11
4-15. Removing Rear Cover-----	4-12
4-16. Replacing Ozone Filter-----	4-12
4-17. Removing Development Unit-----	4-14
4-18. Removing Paper Tray-----	4-14
4-19. Removing Paper Feed Guide Plate-----	4-15
4-20. Removing OPC Belt Cassette-----	4-16
4-21. Cleaning OPC Cassette Receptacle-----	4-16
4-22. Removing Dust-Proof Cover-----	4-17
4-23. Unlocking OPC Belt Tension Levers-----	4-17
4-24. Removing OPC Belt-----	4-18
4-25. Installing New OPC Belt-----	4-19
4-26. Checking the Synchronizing Mark-----	4-20
4-27. Removing Development Unit-----	4-21
4-28. Removing Lens Cover-----	4-21
4-29. OPC Sensor Cleaning-----	4-22
4-30. Lens Cleaning-----	4-23
4-31. Removing the Paper Tray-----	4-23
4-32. Paper-Out Sensor Cleaning-----	4-24
5-1. Monitor Indicator-----	5-2
5-2. Opening Paper Exit Unit-----	5-2
5-3. Opening Paper Exit Cover-----	5-3
5-4. Removing Misfed Paper-----	5-4
5-5. Releasing Fusing Unit Pressure-----	5-4
5-6. Opening Fuser Cover-----	5-5
5-7. Removing Misfed Paper-----	5-6
5-8. Cleaning Separation Pawls-----	5-6
5-9. Cleaning Paper Exit Sensor-----	5-7
5-10. Pulling Out Paper Exit Unit-----	5-8
5-11. Removing Paper-----	5-8
5-12. Opening Paper Exit Cover-----	5-9
5-13. Releasing Fuser Unit Pressure-----	5-9
5-14. Removing Paper-----	5-10
5-15. Opening Paper Tray Cover-----	5-11
5-16. Removing Misfed Paper-----	5-11
5-17. Printer and Controller Self Test Switches-----	5-16
5-18. Printer Self Test Printout-----	5-17
5-19. Controller Self-Test Printout-----	5-17

## LIST OF TABLES

1-1. Power Source-----	1-3
1-2. Safety Compliance Listing-----	1-12
5-1. Service Required Indicator-----	5-12

26884

# 2688A

## SECTION I. GENERAL INFORMATION

### INTRODUCTION

The 2688A Operator's Manual contains information about operating and maintaining the HP 2688A Page Printer. Read through the information in this manual before you use your HP 2688A so that you can get the most efficient use of your printer.

The following topics are discussed in this section of the manual:

Product Description

Options

Location Considerations

Useful Information

Operator Safety

### PRODUCT DESCRIPTION

The HP 2688A Series 1200 Page Printer consists of an HP 2683A Printer and an HP 26088A Controller. The HP 2688A is a non-impact page printer which uses the latest improvements in laser printing technology to produce high-quality output. The printer's high resolution of 90,000 dots per square inch permits the HP 2688A to produce superbly sharp images. Added sharpness is assured by the use of a highly sensitive organic photoconductor (OPC) belt coupled with a single-component toner.

The HP 2688A is also designed for easy operation. The OPC belt is housed in a cassette for easy installation and removal, and adding paper and toner takes only a few moments to perform. Easy-to-use controls allow the user to spend a minimum of time learning to operate the printer.

The HP 2688A has the capability of printing 32 character sets per page and can print graphics with or without merged text. Many type families are available from Hewlett-Packard's Computer Supplies Operation. Each family includes four timesteps (regular, bold, italic, and bold-italic) and multiple point sizes (ranging from 4-point to 36-point) providing a total of 37 character sets per family.



## OPTIONS

The standard HP 2688A is configured for 115 Vac 60 Hz operation and comes equipped with an HP-IB interface. Options available from the factory are as follows:

- Option 015 - Configured for 220V, 50Hz operation
- Option 017 - Configured for 240V, 50Hz operation
- Option 340 - Configured for use with HP 3000 Series 39/40/42
- Option 344 - Configured for use with HP 3000 Series 44/48
- Option 364 - Configured for use with HP 3000 Series 64/68

## LOCATION CONSIDERATIONS

The performance of the HP 2688A is greatly affected by the environmental conditions where it is installed. Given below are suggestions for locating your HP 2688A for optimal performance. See "Getting Your Printer Ready For Operation" in Section III of this manual for more installation information.

### Environmental Conditions

- a. Avoid installing in a place subject to direct sunlight or in an excessively illuminated place (illumination not exceeding 2000 lux) to protect the OPC belt from degradation.
- b. Locate in a place where a temperature range of 50 to 86 degrees Fahrenheit (10 to 30 degrees C) and a humidity range of 20 to 80% are maintained to prevent faulty paper transport and assure consistent image quality.
- c. Avoid installing in a poorly ventilated place ( $30^3\text{m/hr/person}$ ) to prevent excessive temperature rise in the HP 2688A.
- d. Avoid installing in a dusty place (up to  $0.15\text{ mg/m}^3$ ) to protect moving parts from wear.
- e. To prevent condensation, avoid installing in an air-conditioned place where:

The HP 2688A is subjected to sudden changes from low temperature to high humidity and high temperature conditions

The HP 2688A is exposed directly to a draft of hot or chilled air from an air conditioner or similar unit.

- f. Use at altitudes not exceeding 2500 meters (8200 ft.) to avoid defective images.

## 2688A

**Mounting**

Install your printer on the HP 26088A controller cabinet. During installation, adjust the rubber legs so that the printer is no more than 5 mm (.2 inches) from level (see figure 1-1).

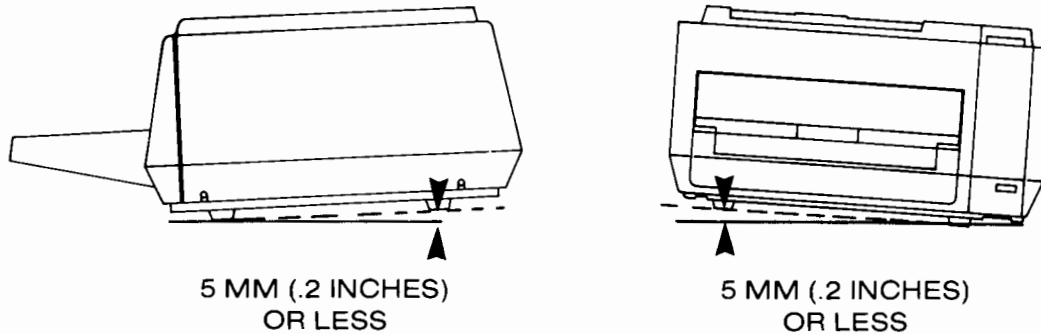

Figure 1-1. Installing Your HP 2688A

**Power Source**

Select a power source of 15A or more with one of the following voltages according to what is appropriate.

TABLE 1-1. POWER SOURCE

115 V printer	103.5 - 126.5 V
220 V printer	198 - 242 V
240 V printer	216 - 264 V

# 2688A

## Printer Positioning

The following two figures (1-2 and 1-3) show how the printer is positioned on the HP 26088A controller cabinet.

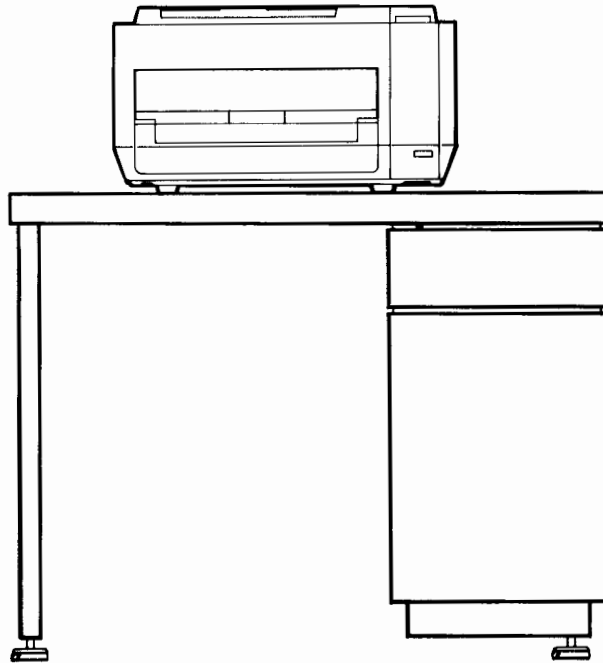

Figure 1-2. Front View

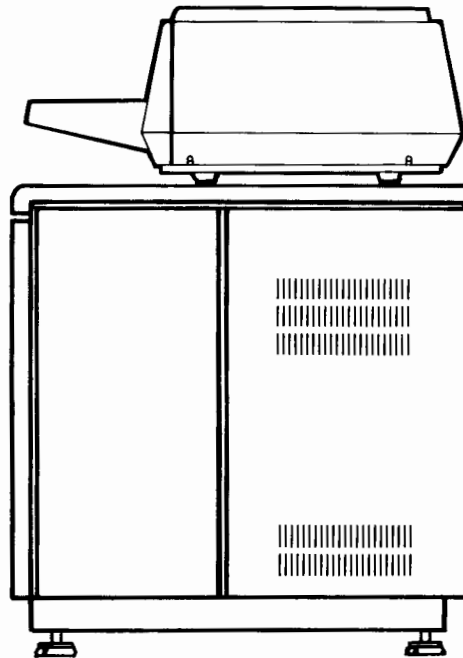

Figure 1-3. Side View

# 2688A

## Minimum Clearance Requirements

Install the HP 2688A printer in a place near two power outlets, taking care to leave clearance around the controller cabinet as shown in figure 1-4.

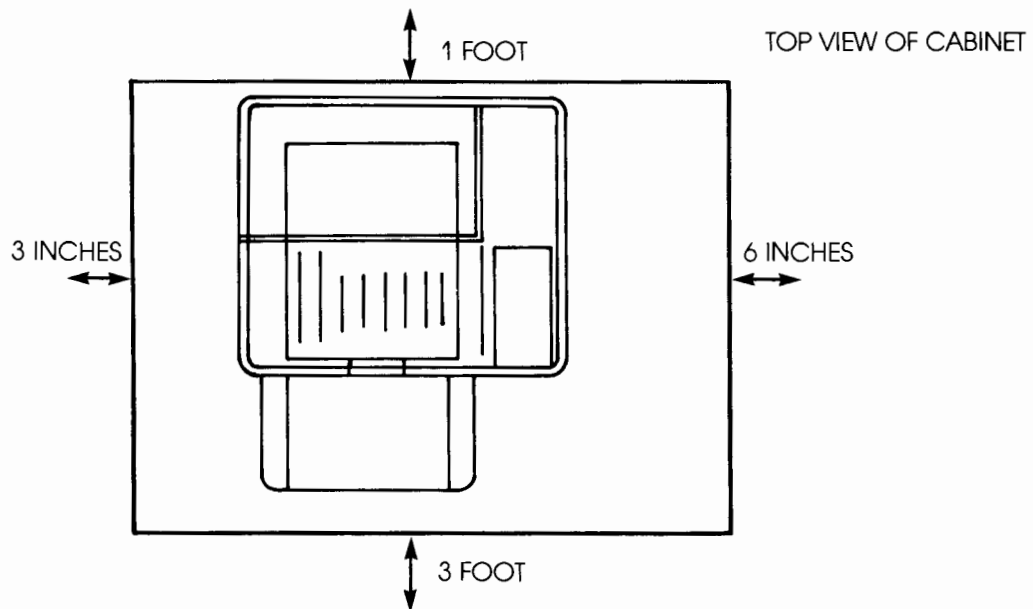

Figure 1-4. Minimum Clearance Requirements

## Cautions In Relocation

Moving the printer with the toner loaded could cause toner to spill inside the machine because of vibration. Be sure to remove the development unit and toner disposal bottle (see figure 4-17) before relocating your HP 2688A. If you are moving the printer long distances, please consult an HP Service Representative.

## USEFUL INFORMATION

### Specifications

#### PHYSICAL

Printer:

Width: 20.0" (51 cm)

Depth: 19.5" (50 cm)

Height: 11.0" (28 cm)

Weight: 138 lbs. (62.7 Kg)

2688A

**Controller:**

Width: 37.0" (94 cm)

Depth: 28.0" (71 cm)

Height: 29.0" (74 cm)

Weight: 116 lbs. (52.7Kg)

**ELECTRICAL**

**Voltage/Frequencies**

115V +/- 10% 60 Hz

220V +/- 10% 50 Hz

240V +/- 10% 50 Hz

Power Consumption at 115 Vac: 1068 Watts printing (max.)

**ENVIRONMENTAL**

Ambient Temperature: Maximum rate of change--20 degrees C/hour without reaching dew point

50 to 86 degrees F (10 to 30 degrees C) Operating

-40 to 131 degrees F (-40 to 55 degrees C) Storage (printer and OPC belt)

-40 to 104 degrees F (-40 to 40 degrees C) Storage (toner)

Humidity: 20 - 80% RH @ 50 to 86 degrees F (10 to 30 C) Operating

10 - 90% RH @ 50 to 86 degrees F (10 to 30 C) Storage

Altitude: 0 to 8200 feet (0 to 2500 metres) Operating 0 to 49,200 feet (0 to 15,000 metres)  
Non-operating

Acoustic Noise: Less than 55 dBA (53 dBA tested)

**PRINT CAPACITY**

Print Speed: First page less than 15 seconds after receipt of data or after any of the printer doors are closed; subsequent pages are printed at a rate of up to 12 pages-per-minute; print speed will be application- dependent and system-dependent.

**2688A**

Warm-Up Time: 90 seconds

Paper Capacity: 250 sheets, single input tray; 250 sheets single-output bin

Paper Feed: Single sheet, automatic feed; simplex printing (one-sided); correct-order stacking

#### DEVELOPMENT PROCESS

Dry-type electrophotography using single-component toner

#### PAPER

##### PAPER WEIGHT

Hewlett-Packard recommends 60 gm/m<sup>2</sup> to 90 gm/m<sup>2</sup> (16 to 24 pound) bond paper. Refer to the Paper Specifications Guide (part no. 5953-7132) for more information concerning printer paper.

##### PAPER SIZE AND PRINT IMAGE AREA

Print quality is specified within the image areas shown in figures 1-5 and 1-6. However, it is possible to print within 1/4" of the leading edge of the paper and within 1/4" of the left and right margins with some potential print quality degradation.

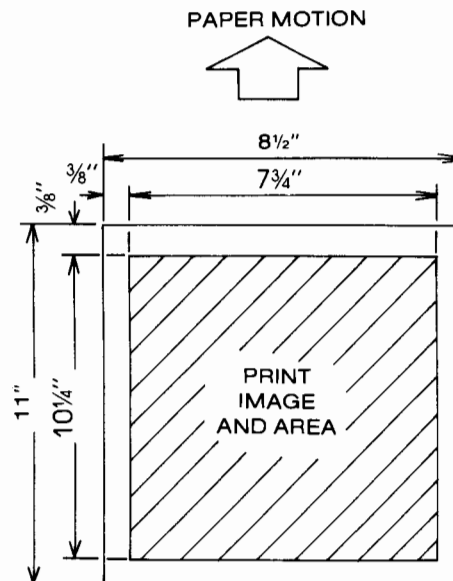

Figure 1-5. Paper Size Image Area  
(8 1/2 x 11 in. paper)

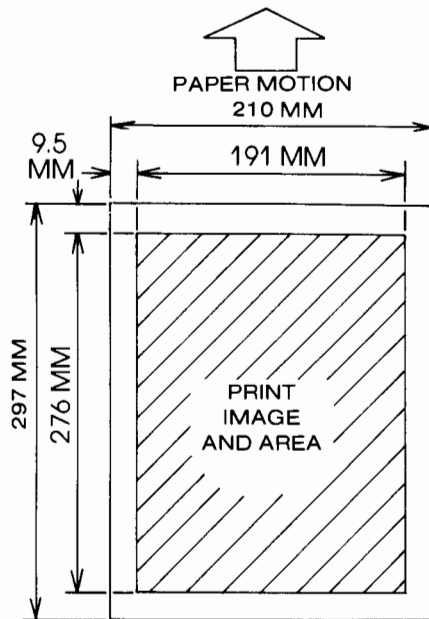

Figure 1-6. Paper Size Image Area (A4 paper)

#### PAPER CONDITIONING

Before using a new box of paper, allow the paper to adjust to room temperature and humidity for 24 hours. Doing so will optimize the feeding and handling capabilities of the paper.

#### PRINT SPEED

The actual throughput of the HP 2688A Printer is based on the number of pages printed per minute and is dependent on the complexity of the print environment and the usage level of the computer system at the time of printing. The maximum print speed for both 8 1/2" x 11" and A4 paper is 12 pages per minute.

#### PRINTING

**PRINT RESOLUTION:** 300 X 300 Dots per inch

**PRINT ORIENTATION:** Vertical (portrait), Horizontal (landscape--default), Reverse portrait, Reverse Landscape

**2688A**

**CHARACTER FONTS:** A variety of character fonts in multiple pitch and point sizes are provided standard with the printer (for example, Courier 10 and Letter Gothic 12 in regular, bold and italic types). For more complete document formatting flexibility, character font families are available from HP's Computer Supplies Operation.

## Supplies and Accessories

### ORDERING INFORMATION

Consumable supplies and accessories may be ordered directly from the HP Computer Supplies Operation (CSO). Direct phone service is available to HP customers within the continental U.S. Orders may be taken from 9 a.m. to 5 p.m. in all U.S. time zones. If it is more convenient, orders may be placed with your local HP Sales and Service Office. In Europe, orders may also be placed with the local HP Sales and Service Office.

800-538-8787 TOLL FREE  
CALIFORNIA (408) 738-4133 COLLECT

### CONSUMABLE SUPPLIES

**Toner**, part no. 92185A (box of 6 plus disposal bottle; 18,000 pgs./pkg.)

**Fuser Cleaning Pad Assembly**, part no. 92185B (box of 3; 30,000 pgs./pkg.)

**Ozone Filter**, part no. 92185D (box of 3; 60,000 pgs./pkg.)

**OPC Belt**, part no. 92185E (box of 3; 60,000 pgs./pkg.)

**Paper**, part no. 92185P (8 1/2" x 11")

### CABLING

An 8-metre HP-IB interface cable (part number 8120-3449) is supplied with the HP 2688A. If cable lengths longer than 8 metres are desired, contact your HP Service Representative so that your printer's cable loading requirements can be met. Using a longer cable with the wrong loading could result in loss of data integrity.

### RELATED DOCUMENTS

2683A Print Engine Service Manual (part no. 02683-90904)

26088A Service Manual (part no. 26088-90904)



## OPERATOR SAFETY

Safety is a principal rule in working with all electro-mechanical equipment. While operating the HP 2688A printer, the operator should always keep safety in mind. Although the machine has been designed to comply with industrial safety standards, as listed in table 1-2, it is still the operator's responsibility to be knowledgeable of safety practices and procedures and to heed all safety labels and indicators.

Caution and warning messages are included throughout this manual. These messages alert the operator to more potential hazards whether they be electrical or mechanical. The WARNING messages indicate that if a specific procedure or practice is not followed correctly, injury could occur. The CAUTION messages precede procedures which, if not observed, could result in damage or destruction to equipment.

Due to the printer's design, which integrates electronics, mechanics, and laser technology, several areas throughout the printer have been labeled to alert the operator of potential dangers. All labels must be heeded to avoid possible operator injury and printer damage. Figure 1-7 identifies the labels and their locations.

In addition to the safety labels, the following safety practices should be observed to prevent operator injury and equipment damage:

Any servicing, adjustment, maintenance, or repair of this printer beyond operator maintenance, must be performed **ONLY** by a trained HP Service Representative.

Keep hands, hair, necklaces, and articles of clothing such as long sleeves away from moving parts of the printer.

Keep covers in place and doors closed while operating the printer.

Do not place liquids or any contaminating substance on top of the printer. Possible spillage could result in damage to the printer.

In handling toner, avoid inhalation and ingestion. **DO NOT RECYCLE** toner recovered by the disposal bottle. Extensive damage to the printer could occur.

The preheater area may be hot. Always maintain caution while working near this area.

The HP 2688A is designed in compliance with the codes and regulatory agencies as listed in table 1-2.

26884

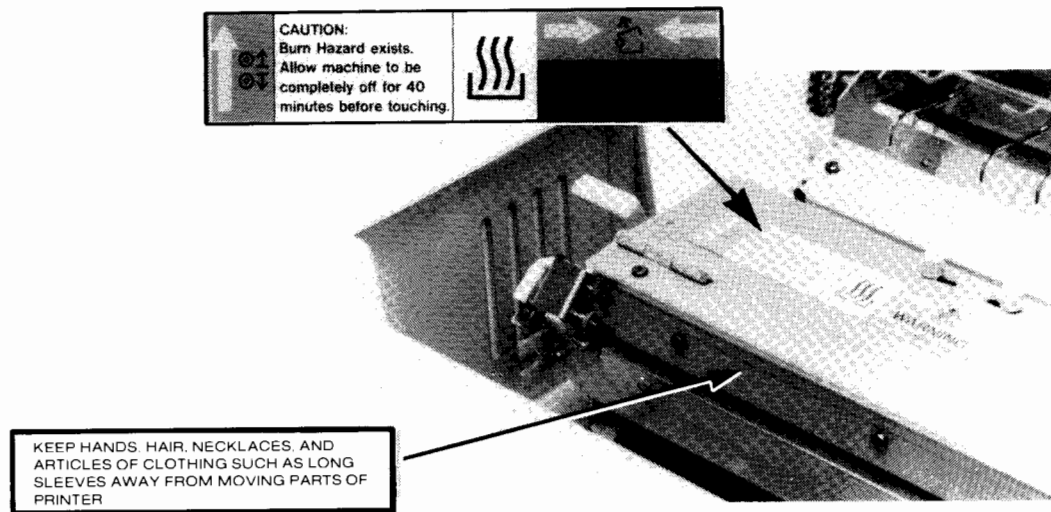

Figure 1-7. Safety Labels

**WARNING**

Performance of procedures other than those specified herein may result in hazardous laser light exposure.

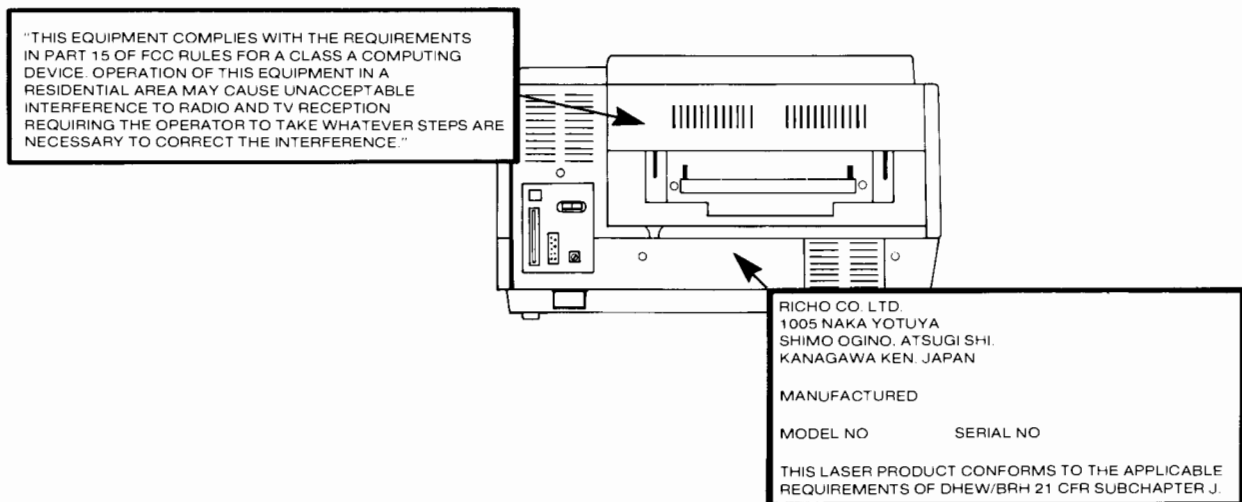

Figure 1-8. Conformance Labels

26884

TABLE 1-2. SAFETY COMPLIANCE LISTING

Underwriter's Laboratories, Incorporated (UL 478, UL 114) Standard of Data Processing Equipment

VDE 0806 - German Standard for Data Processing Equipment

VDE 0871 - German Standard for Radio Frequency Interference

VDE 0836 - Electrical Safety of Laser Equipment and Installations

**FEDERAL COMMUNICATIONS COMMISSION  
RADIO FREQUENCY INTERFERENCE STATEMENT**

The Federal Communications Commission (IN 47 CFR 15.818) has specified that the following notice be brought to the attention of the users of this product.

**Warning:** This equipment generates, uses, and can radiate radio frequency energy and if not installed and used in accordance with the instructions manual, may cause interference to radio communications. It has been tested and found to comply with the limits for a Class A computing device pursuant to Subpart J of Part 15 of FCC rules which are designed to provide reasonable protection against such interference when operated in a commercial environment. Operation of this equipment in a residential area is likely to cause interference in which case the user, at his own expense, will be required to take whatever measures may be required to correct the interference.

State safety codes and regulations may exist covering the installation and operation of a BRH Class laser device. These rules and regulations may vary from state to state, therefore it is the responsibility of the customer to ensure that all safety codes, rules and regulations are adhered to. HP will provide assistance in helping customers determine state safety conventions.

**2688A**

## **SECTION II. CONTROLS AND INDICATORS**

### **INTRODUCTION**

Operating the HP 2688A Page Printer consists primarily of understanding the use of the controls and indicators. The following topics are discussed in this section of the manual:

Functional Description of Components

Power Controls

# 2688A

## FUNCTIONAL DESCRIPTION OF PRINTER COMPONENTS

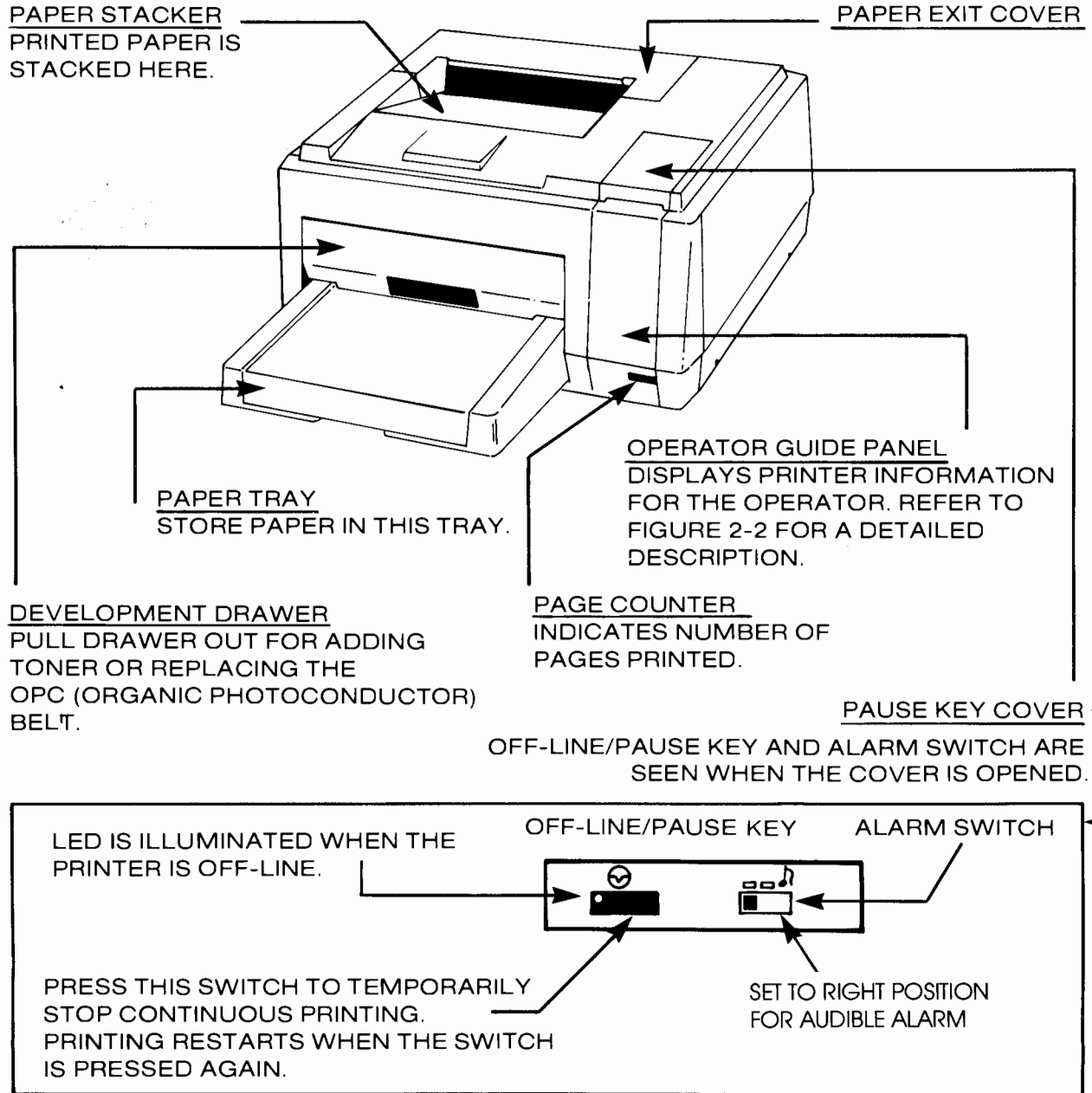

Figure 2-1. HP 2688A Laser Page Printer

2688A



### Printer Operator Guide Panel Description

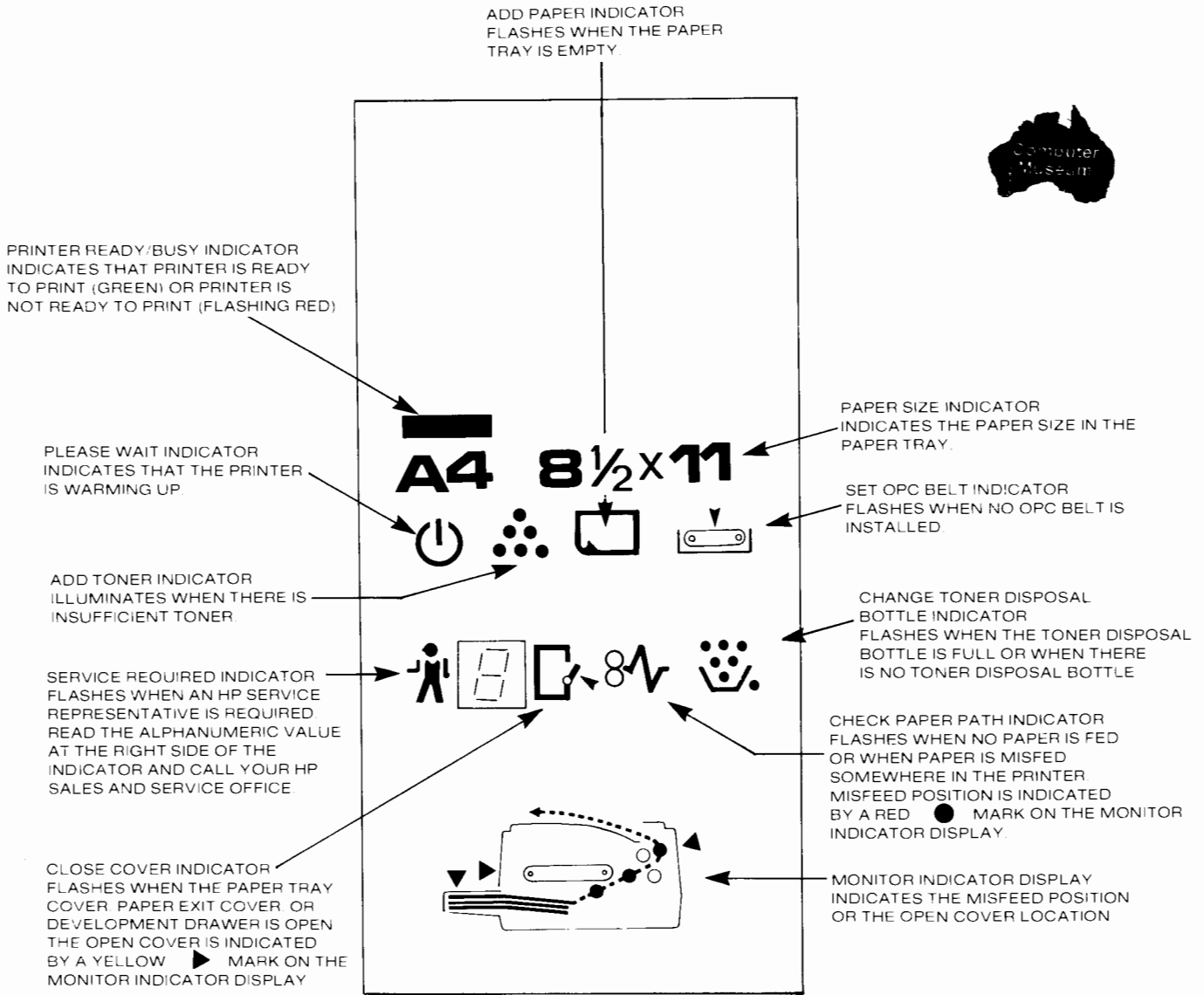

Figure 2-2. Printer Operator Guide Panel

# 2688A

## HP 26088A Controller Description

The following two figures (2-3 and 2-4) show the controller and the controller's rear panel.

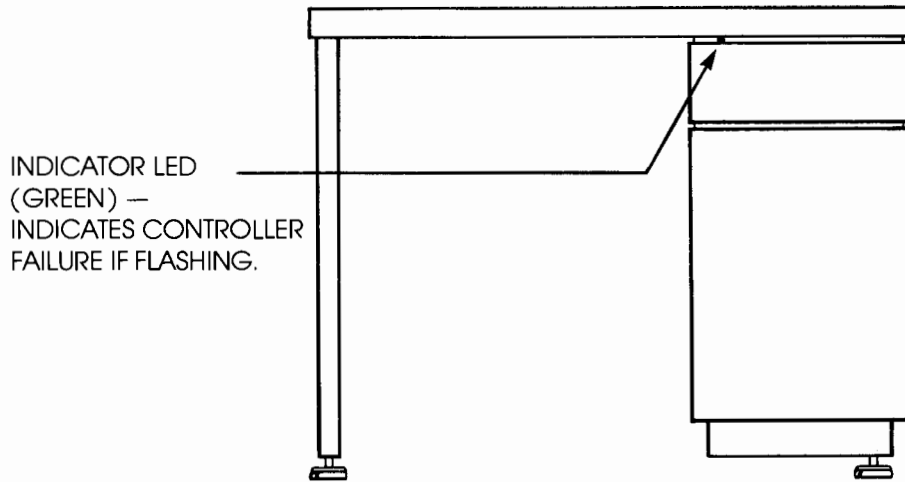

Figure 2-3. HP 26088A Controller

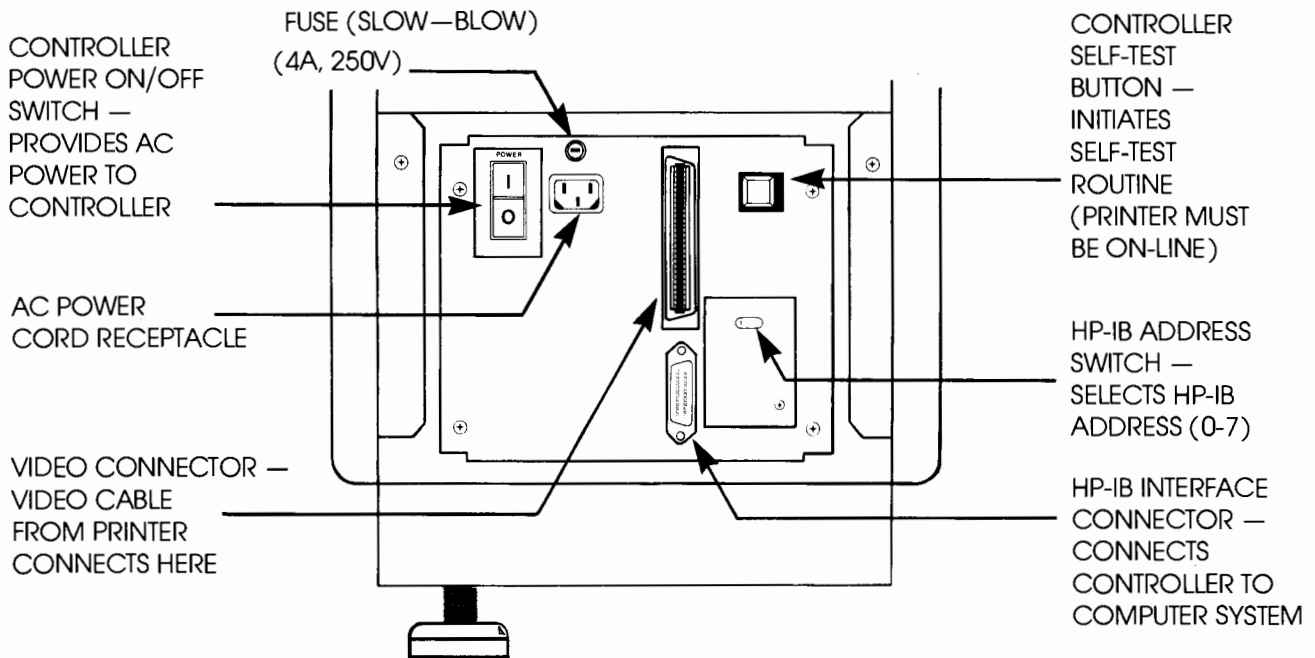

Figure 2-4. HP 26088A Controller Rear Panel Description

2688A

## POWER CONTROLS

### Power ON/OFF Switch

This is the operator's ON/OFF switch. Located on the back of the printer, the Power ON/OFF (I/O) switch provides AC power to the printer. A separate Power ON/OFF switch, located on the controller's rear panel, provides power to the controller.

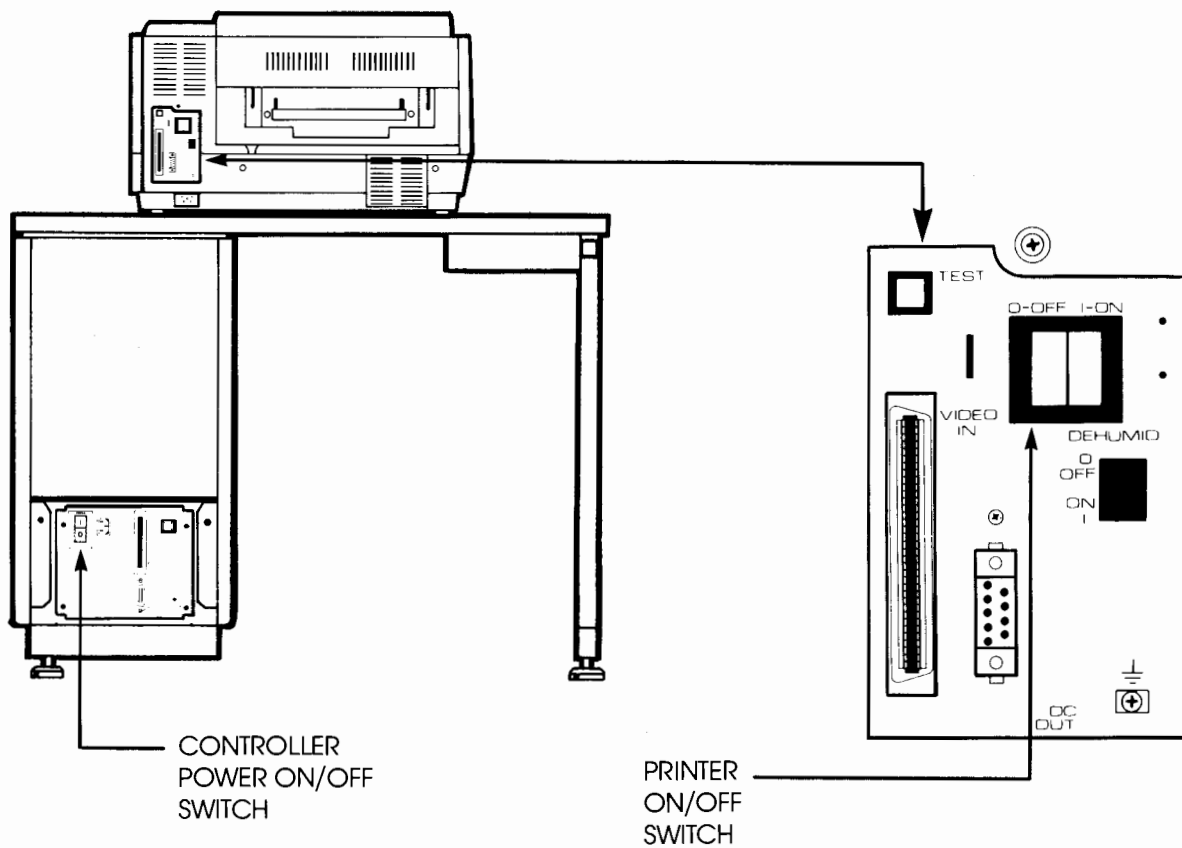

Figure 2-5. Power ON/OFF Switches



26884

**2688A**

## SECTION III. PREPARING THE PRINTER FOR USE

### INTRODUCTION

This section is written primarily to assist the operator in preparing the HP 2688A printer for use. The following procedures are contained in this section:

Getting Your Printer Ready For Operation

Paper Loading

Adding Toner

Setting the HP-IB Address

Although not all of these procedures must be performed each time the printer is operated, it is important that the operator read and be able to perform each procedure.

### GETTING YOUR PRINTER READY FOR OPERATION

Once your printer is unpacked and inspected (as shown in the unpacking instructions that come with your printer), the cables must be connected and the printer tested. Perform the following operations to ready your printer for operation:

#### **WARNING**

Do not attempt to lift the printer alone. Two people are required to prevent injuries; the printer weighs 138 pounds (62.7 kg).

- a. Set the printer on the controller cabinet as shown in figure 3-1.
- b. Add paper and toner as described in the Paper Loading and Adding Toner procedures in this section.
- c. Install the OPC belt as described in the OPC Belt Replacement procedure in section IV of this manual.

26884

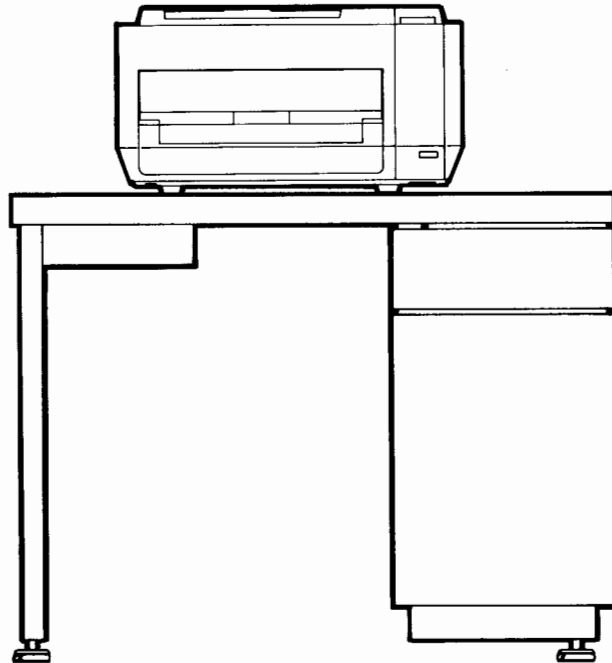

Figure 3-1. Positioning the Printer

- d. Connect the printer's AC power cord to the AC input power receptacle on the printer and plug the other end into the AC power outlet (see figure 3-2).

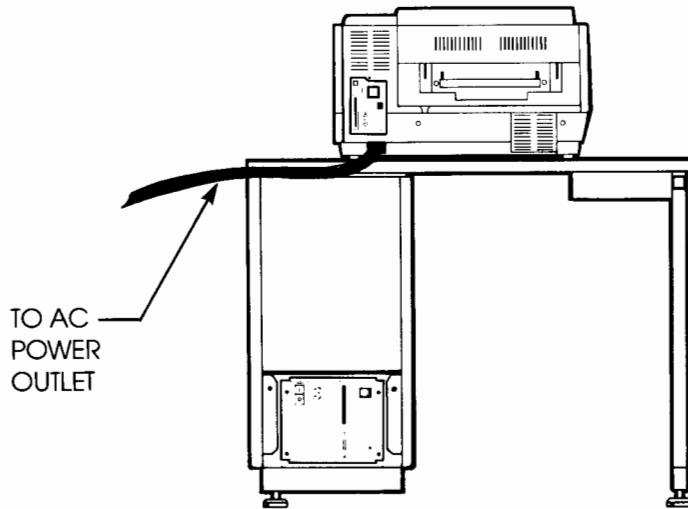

Figure 3-2. Connecting Printer's Power Cord

- e. Connect the controller's AC power cord to the AC input power receptacle and plug the other end of the cord into the AC power outlet (see figure 3-3).

# 26884

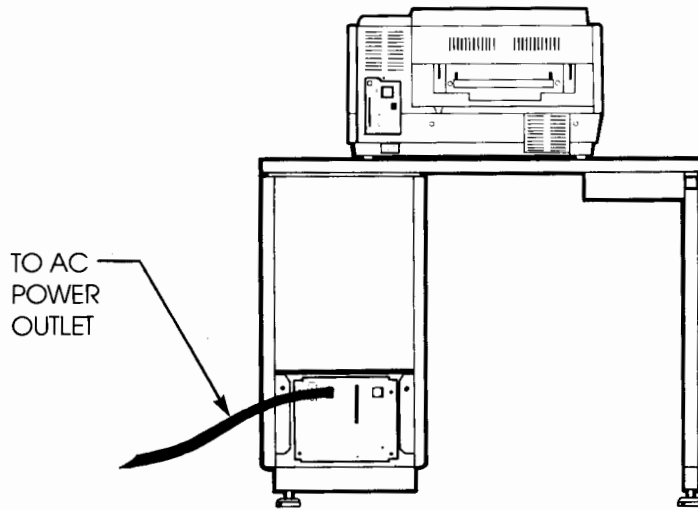

Figure 3-3. Connecting Controller's AC Power Cord

- f. Connect the video cable from the VIDEO IN connector on the back of the printer to the connector on the controller's rear panel (see figure 3-4).

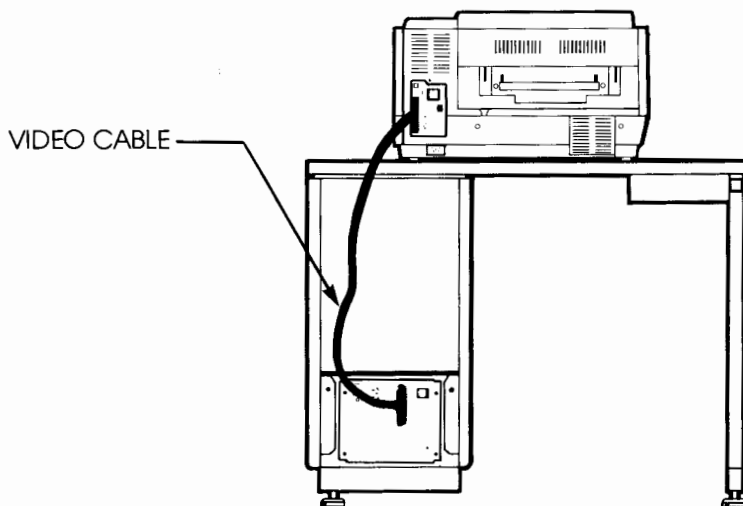

Figure 3-4. Connecting Video Cable

- g. Switch the power ON/OFF switches on the back of the printer and the controller to the ON (I) position.

- h. Perform self-test as explained in the self-test description in section V of this manual.
- i. Switch the controller's power ON/OFF switch to the OFF (0) position.
- j. Connect the HP-IB cable from the host system to the HP-IB connector on the controller's rear panel (see figure 3-5) and set the HP-IB address as explained at the end of this section (see figure 3-13).

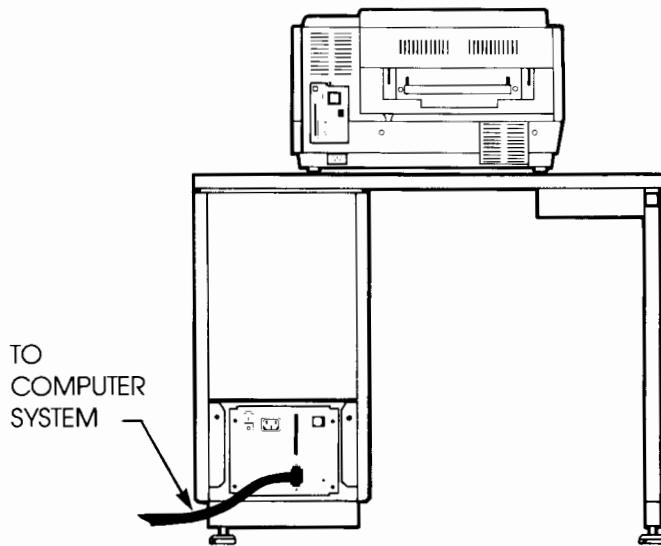

Figure 3-5. Connecting HP-IB Cable

- k. Switch the controller's power ON/OFF switch to the ON (1) position.

Once you have performed these procedures, your computer system must be configured so that it can communicate with your new printer. This can be accomplished by your HP Service Representative.

## PAPER LOADING



The indicator on the left (located on the printer's Operator Guide Panel) flashes when the printer is out of paper. Check the paper tray to ensure that paper is needed. If no paper is in the paper tray, add paper as explained below:

### How To Add Paper

- a. Open the paper tray cover (see figure 3-6).

26888A

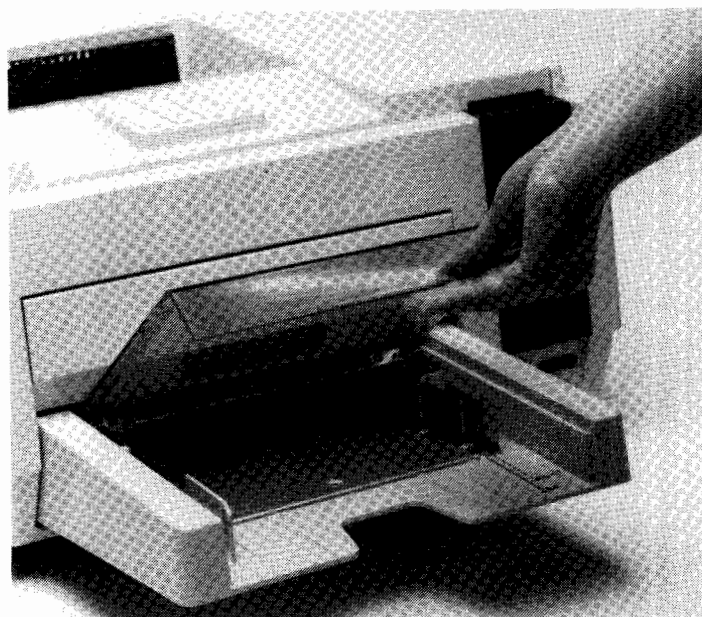

Figure 3-6. Paper Cover

**CAUTION**

This printer was not designed to print on both sides of the paper (duplex printing). **DO NOT** try duplex printing as it causes toner to deposit on the rollers, resulting in a reduction in print quality.

- b. Slide paper into the bottom of the paper tray within the guide plates located on both sides (see figure 3-7).

**NOTE**

Do not add paper above the limit line (see figure 3-8). Place paper in the paper tray with the printing side facing up.

26884

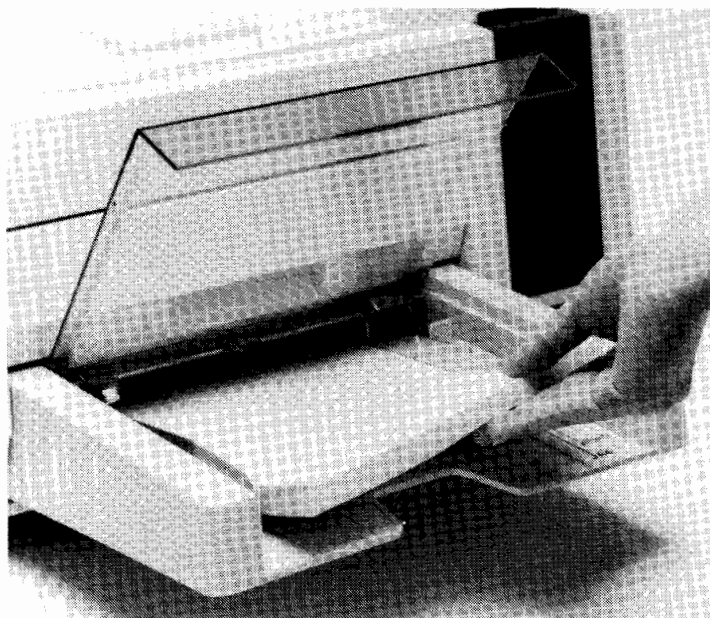

Figure 3-7. Adding Paper

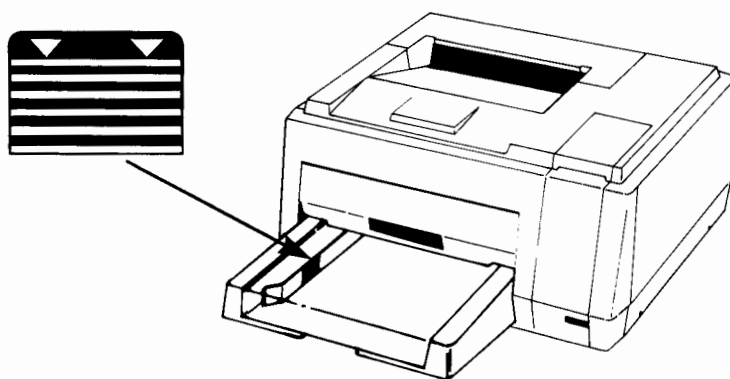

Figure 3-8. Limit Line Location

c. Close the paper tray cover.

# 2688A

## How To Change Paper Size

The HP 2688A prints on two sizes of paper, 8 1/2 x 11 inches and A4 size. Follow the directions given below to change paper size.

If the paper size is to be changed:

- a. Open the paper tray cover.
- b. Change the paper size to the desired size setting by changing the position of the paper guide in the paper tray (see figure 3-9).

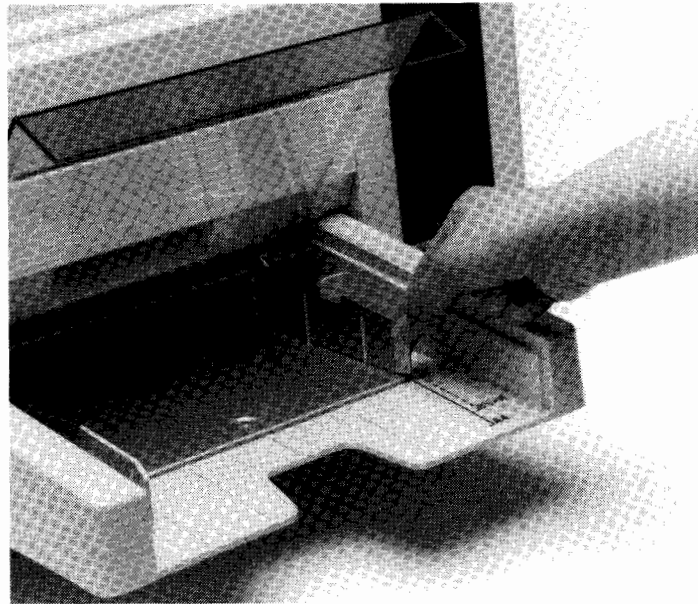

Figure 3-9. Paper Guide Positioning

- c. Check that the paper size indicator on the Operator Guide Panel is correct.
- d. Add paper to the bottom of the paper tray along the guide plates located on both sides (see figure 3-7). Place paper in the paper tray with the side to be printed facing upward.
- e. Close the paper tray cover.

## ADDING TONER

In electrophotographic printing, toner is the dry "ink" used to print the image on the paper. Once the toner has been electrostatically attracted to the paper, it is fused (melted) into the paper and a permanent printed image is created.



When this indicator illuminates, there is insufficient toner in the printer. Add toner as described below.



- a. Pull out the development drawer until it locks (figure 3-10).

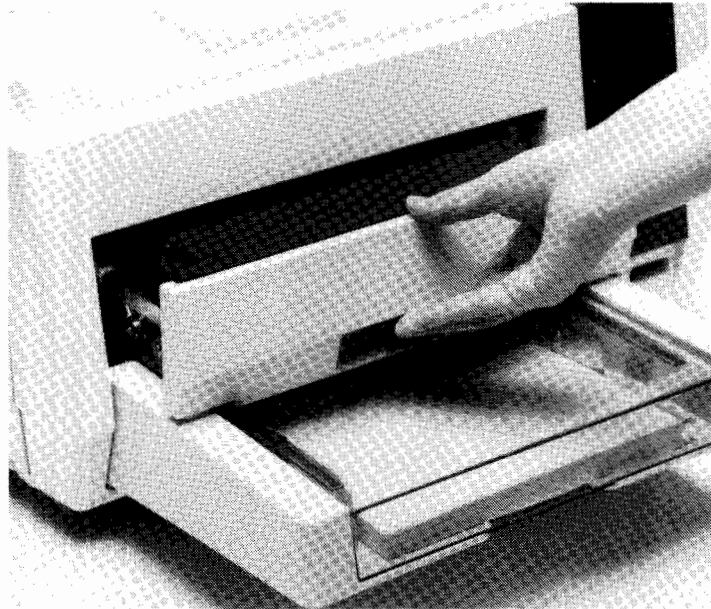

Figure 3-10. Pulling Out Development Drawer

**CAUTION**

Use only toner that is designed for use in the HP 2683A, specifically part number 92185A available from Hewlett-Packard Computer Supplies Operation. DO NOT use toner designed for use in other printers and copiers. All other types of toner will damage the printer.

- b. Open the toner inlet cover (black) as shown in figure 3-11.

26884

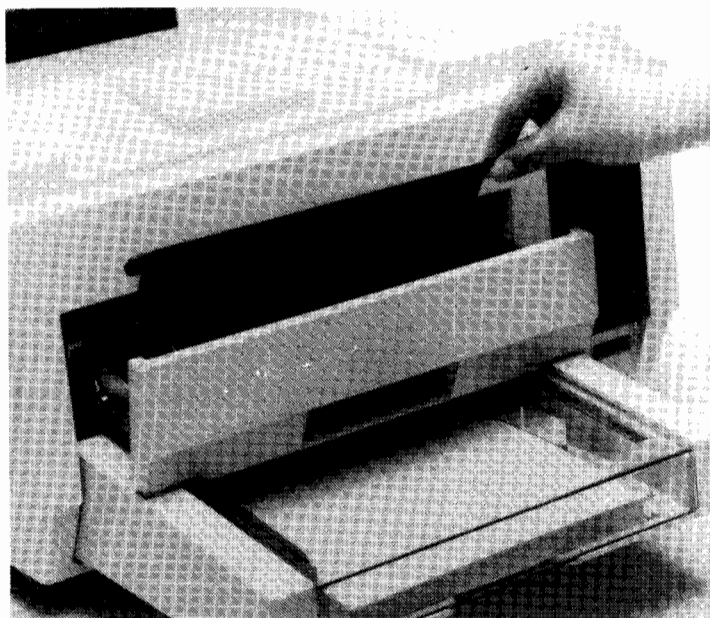

Figure 3-11. Opening Toner Inlet Cover

- c. Shake the toner bottle twenty or more times before opening and then carefully pour the toner into the developing tank, distributing toner equally across the drawer (figure 3-12).

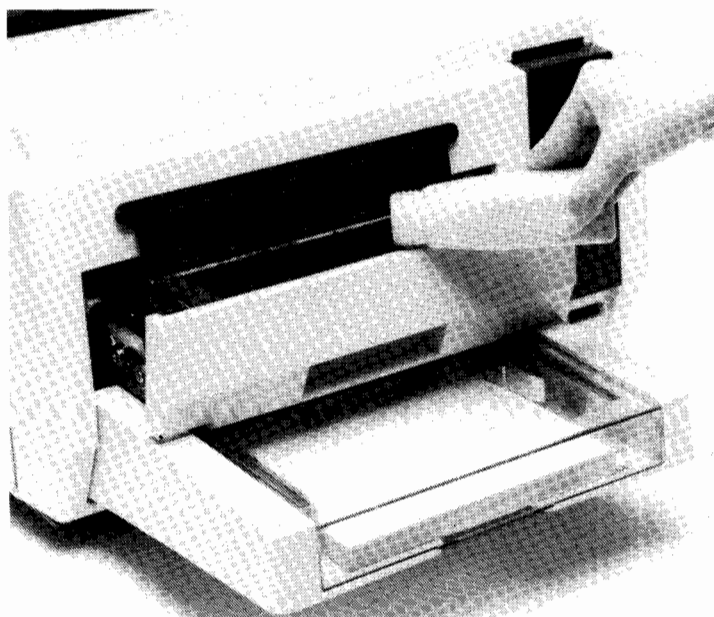

Figure 3-12. Pouring Toner

- d. Close the toner inlet cover.
- e. Push the development drawer back into the original position. Be sure the drawer is closed as completely as possible. Failure to do so may decrease print quality.

# 2688A

**NOTE**

Make sure that the development drawer is back in position and the "Close Cover" indicator on the Operator Guide Panel is not illuminated.

## SETTING THE HP-IB ADDRESS

To change the HP-IB address, insert a flat-bladed screwdriver into the slot to the right of the address number and rotate the screwdriver until the desired address number appears in the window.

**WARNING**

The HP-IB cable loading is set by your HP Service Representative to match the cable shipped with your HP 2688A. If you install an HP-IB cable of a different length, the cable loading must be changed. To match the cable loading to your system, call your HP Service Representative.

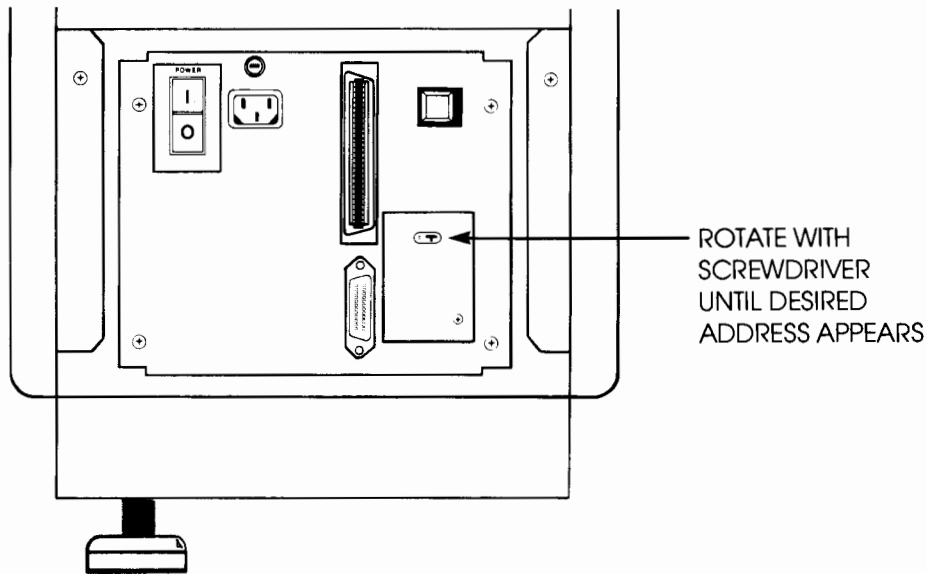

Figure 3-13. Setting the HP-IB Address

**26884**

## SECTION IV. OPERATOR PREVENTIVE MAINTENANCE

### INTRODUCTION

The primary purpose of a preventive maintenance program is to ensure the equipment provides the highest levels of utility and availability for the user. The most fundamental consideration in preventive maintenance of electromechanical equipment is frequent visual inspection. Most mechanical equipment failures give a visual indication of their presence long before the actual failure occurs. The operator's awareness and perception are therefore important. If abnormal or unusual machine functions occur, the operator should closely monitor the printer to see if the failures persist. If they do persist, the operator should inform a Hewlett-Packard Service Representative.

#### CAUTION

The operator should not attempt to perform any maintenance beyond the routine operator maintenance described in this manual.

The following areas of maintenance are to be performed by the operator:

- Corona Cleaning
- Disposal Bottle Replacement
- Fuser Cleaning Pad Replacement
- Ozone Filter Replacement
- OPC Belt Replacement
- Sensor and Second Cylindrical Lens Cleaning

### CORONA CLEANING

The coronas should be cleaned every time you change the disposal bottle or any time you are experiencing print quality problems. To clean the coronas, perform the following procedures:

- a. Open the left cover (figure 4-1).

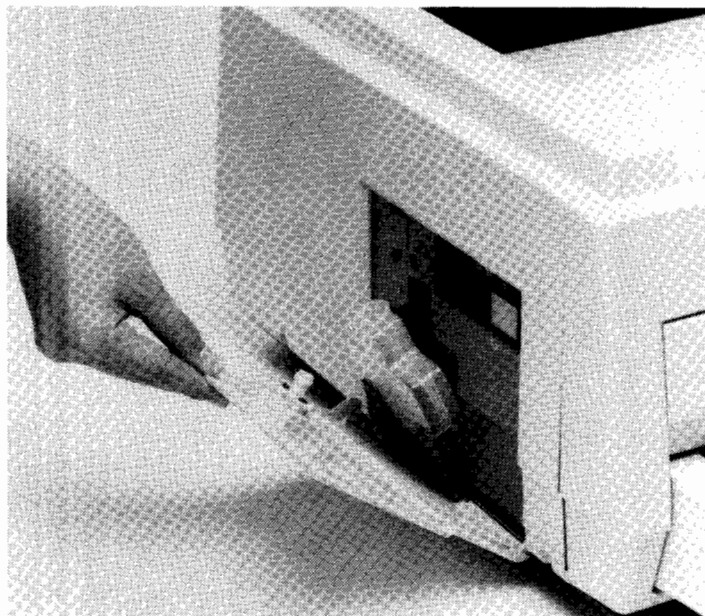

Figure 4-1. Opening Left Cover

**(CHARGE CORONA WIRE CLEANING)**

- b. Pull out the charge corona unit (figure 4-2). The charge corona unit is orange and has a number 1 printed on the handle.

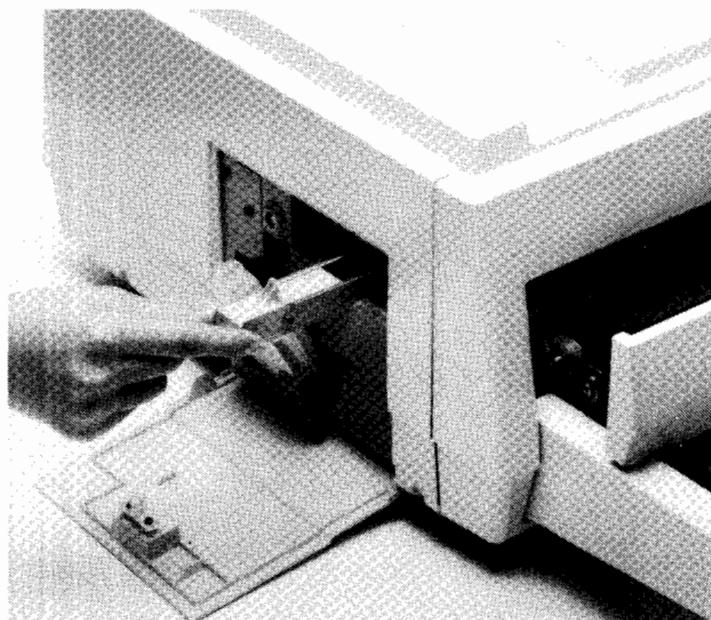

Figure 4-2. Removing Charge Corona

**2688A**

- c. Wipe the charge corona and grid wires with a soft dry cloth (figure 4-3).

**CAUTION**

Do not exert excessive force when wiping the corona; otherwise a wire may break.

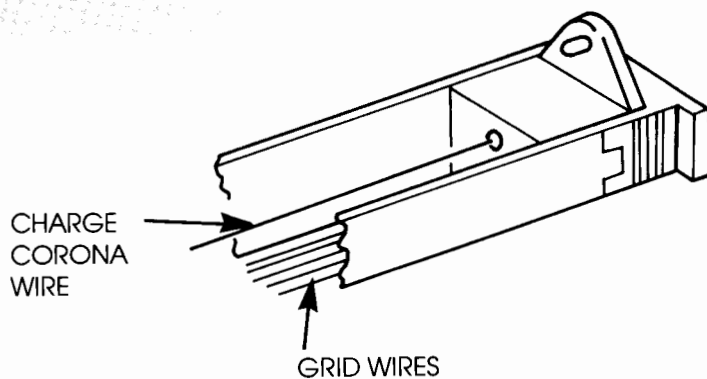
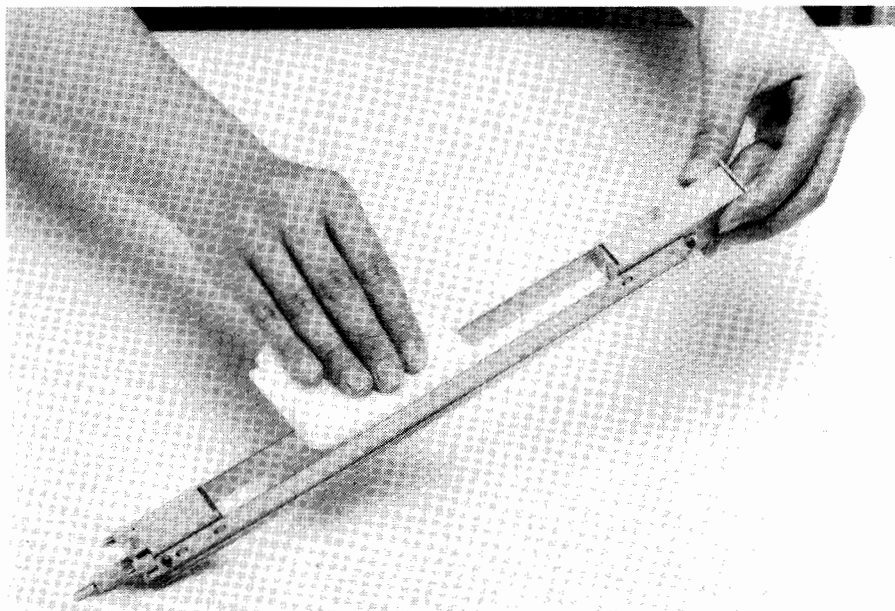

Figure 4-3. Cleaning the Charge Corona

**(TRANSFER CORONA WIRE CLEANING)**

- d. Pull out the development drawer until it locks (figure 4-4).

# 2688A

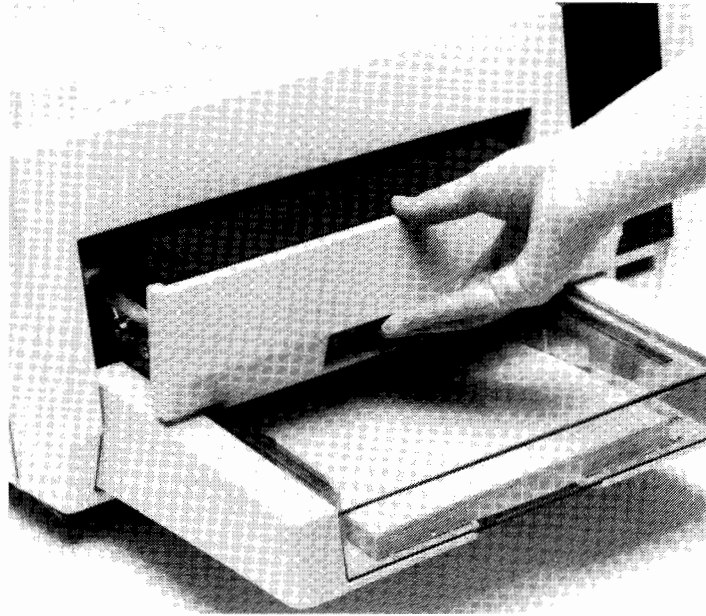

Figure 4-4. Opening Development Drawer

- e. Remove the toner disposal bottle and pull out the transfer corona unit (figure 4-5). The transfer corona is orange and has the number 2 printed on the handle.

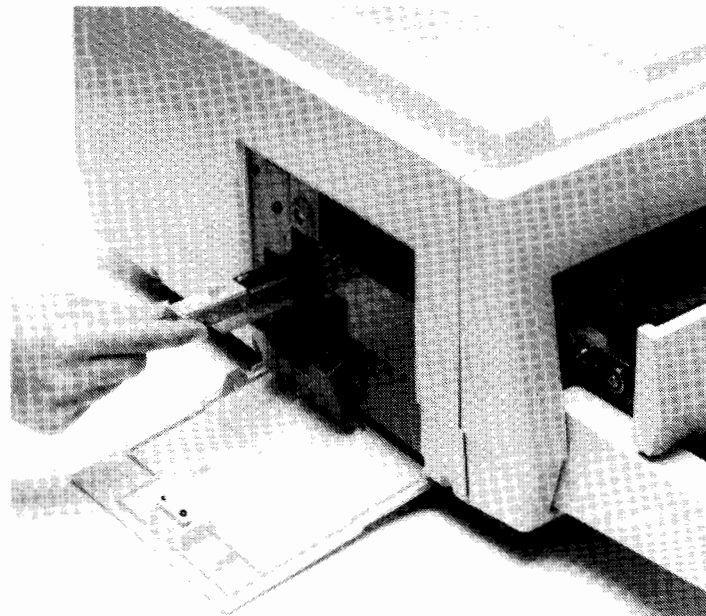

Figure 4-5. Removing Transfer Corona

**2688A****CAUTION**

Do not exert excessive force when wiping; otherwise the wire may break.

- f. Wipe the transfer corona wire with a soft dry cloth (figure 4-6).

**NOTE**

Before re-inserting the transfer corona, make sure that the development drawer has been drawn out to its locked position; otherwise, the transfer corona unit will not fit in place properly.

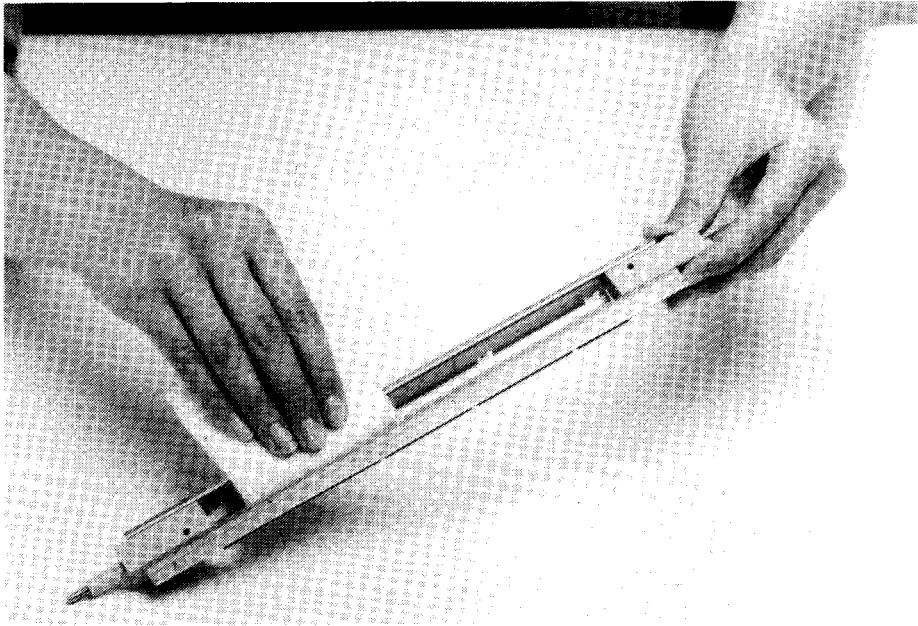

Figure 4-6. Cleaning Transfer Corona

**DISPOSAL BOTTLE REPLACEMENT**

Periodically, the toner disposal bottle will become full of toner and will need to be discarded and replaced. The printer indicates this condition by flashing the Change Disposal Bottle Indicator shown at the left. Replace the disposal bottle by following the procedures described below.



**CAUTION**

DO NOT ATTEMPT TO REUSE THIS TONER IN THE PRINTER. Extensive damage to the printer will occur.

- a. Open the left side cover (figure 4-7).

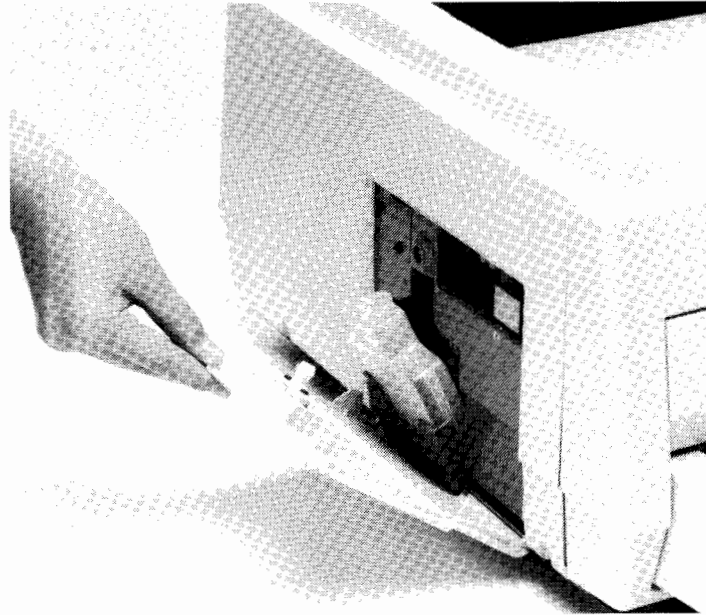

Figure 4-7. Opening Left Side Cover

- b. Gently remove the toner disposal bottle by pulling it out (figure 4-8).

**26884**

Figure 4-8. Removing Disposal Bottle

- c. Replace the full disposal bottle with a new toner disposal bottle. Remove the cap of the new disposal bottle and put it on the old one. Discard the full disposal bottle.
- d. Close the left side cover.
- e. Verify that the "Change Toner Disposal Bottle" indicator on the Operator Guide Panel extinguishes. If it is still flashing, repeat the above procedure using the same bottle.

## FUSER CLEANING PAD REPLACEMENT

Replace the fuser cleaning pad assembly if you are experiencing smudges on the printed paper, or every 20,000 pages (check the page counter under the Operator Guide Panel for the number of pages printed).

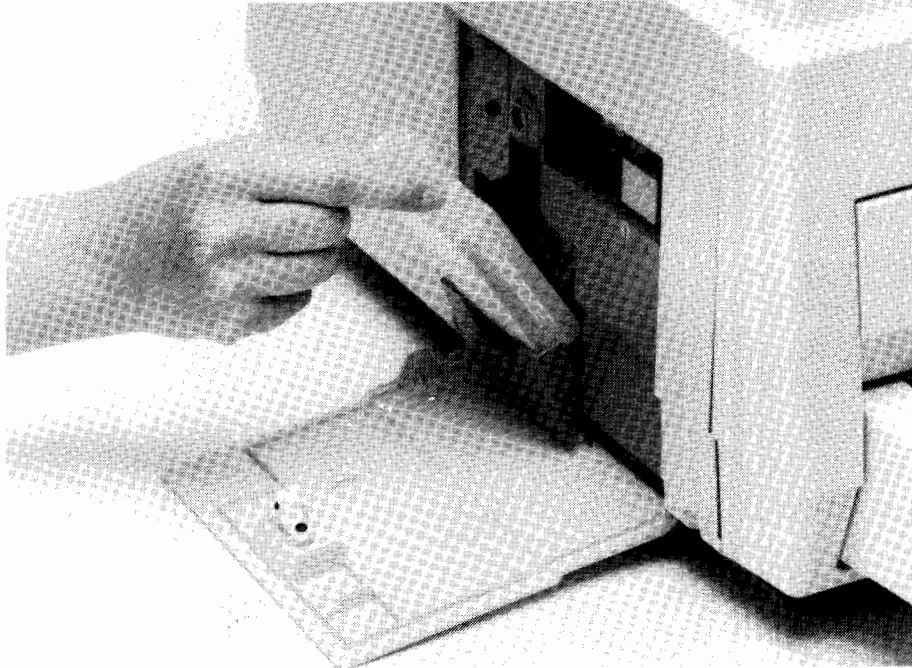
To replace the fuser cleaning pad, proceed as follows:

- a. Pull out the paper exit unit horizontally while lifting up the fuser drawer lever (figure 4-9).

# 26884

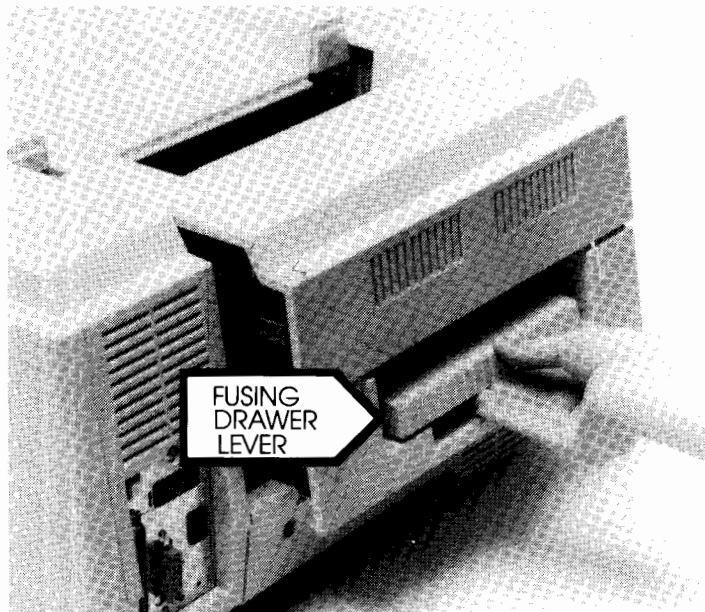

Figure 4-9. Pulling Out Paper Exit Unit

- b. Open the paper exit cover (figure 4-10).

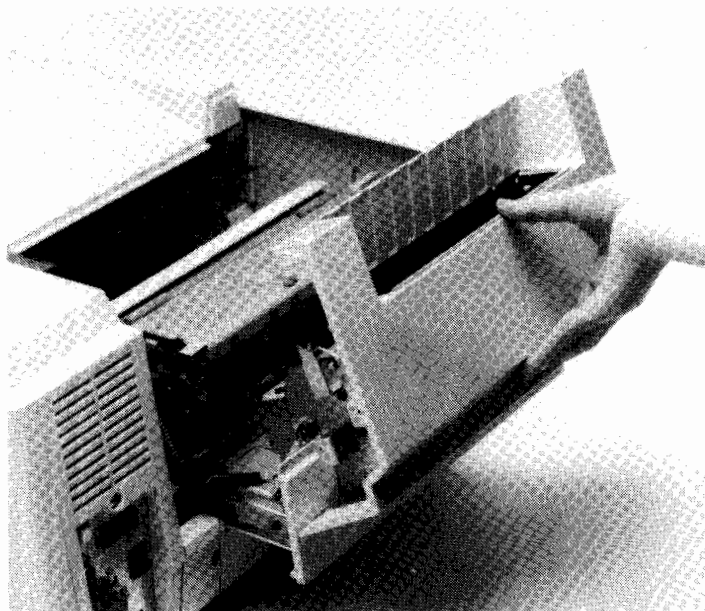

Figure 4-10. Opening Paper Exit Cover

**26887****WARNING**

Burn Hazard exists. Allow machine to cool completely for 40 minutes before touching. Be sure to close the upper cover before pushing the paper exit unit back in.

- c. Open the upper cover (figure 4-11).

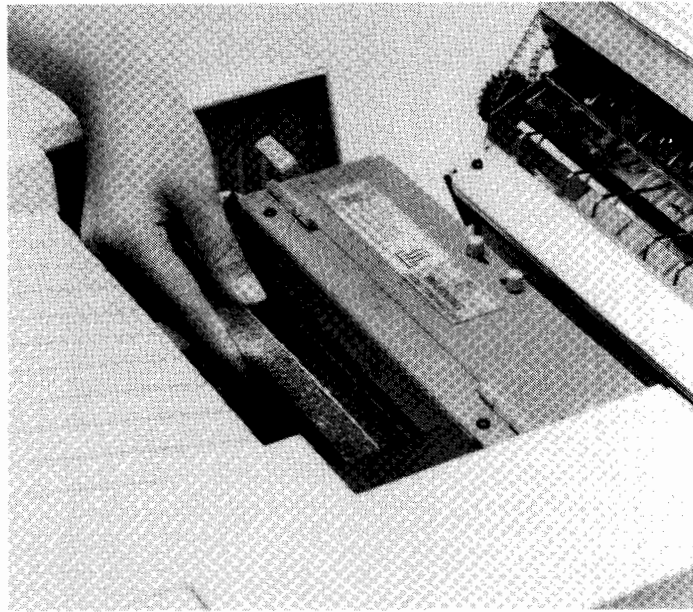

Figure 4-11. Opening Upper Cover

- d. Lay a sheet of paper on the upper cover to catch any toner which may fall when replacing the fuser cleaning pad assembly (see figure 4-12).

2688A

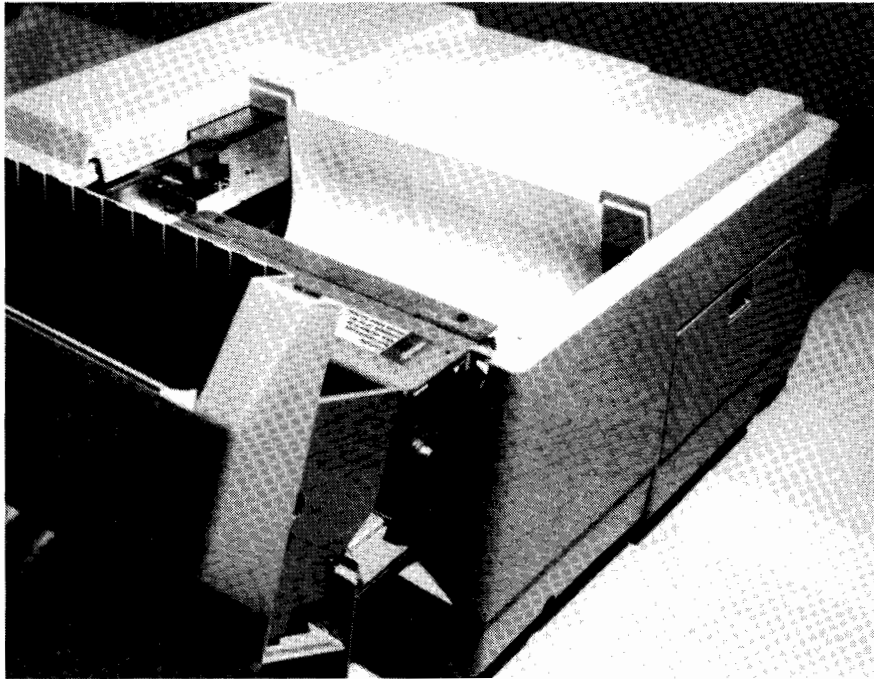

Figure 4-12. Covering Upper Cover With Paper

- e. Grasp the orange tab on one end of the fuser cleaning pad assembly, pull it in the direction of the arrow, and then replace it (figure 4-13).
- f. Wipe the oil-spreading roller with a soft dry cloth while rotating the roller in the direction of the arrow (figure 4-14).

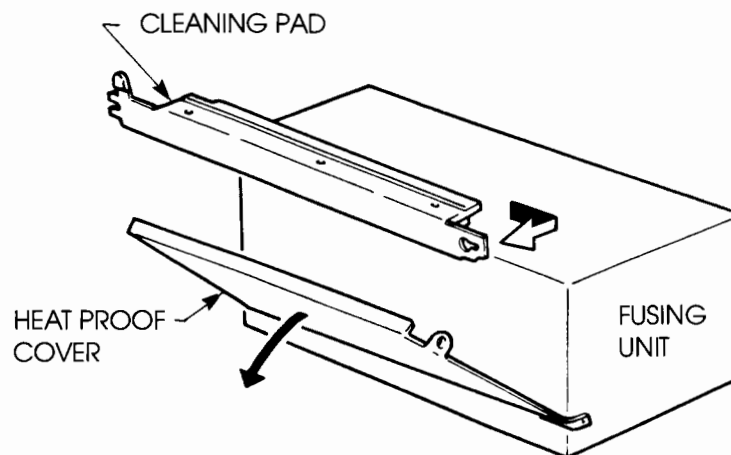

Figure 4-13. Replacing Fuser Cleaning Pad Assembly

**2688A**

Figure 4-14. Cleaning Oil-Spreading Roller

## OZONE FILTER REPLACEMENT

The ozone filter should be replaced every 20,000 pages (see printer page counter) or when you detect an ozone smell coming from the printer.

### NOTE

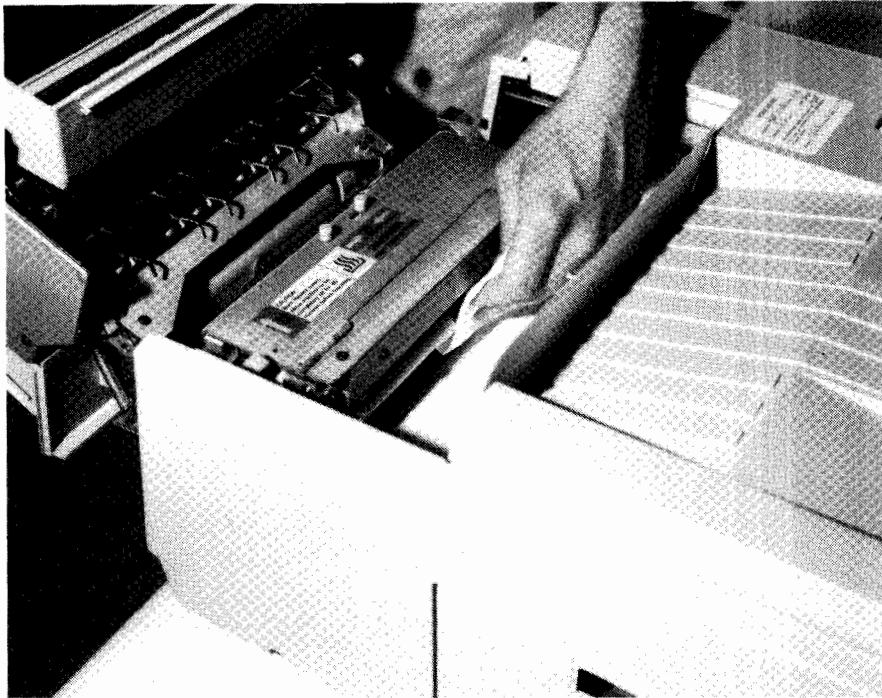
Ozone is a gas formed by electrical discharge and is what people smell when they say they "smell electricity". Most people have noticed the smell of ozone near electric motors and in lightning storms.

To replace the ozone filter, perform the following steps.

- a. Remove the screws on the rear cover with a coin and remove the cover (figure 4-15).

2688A

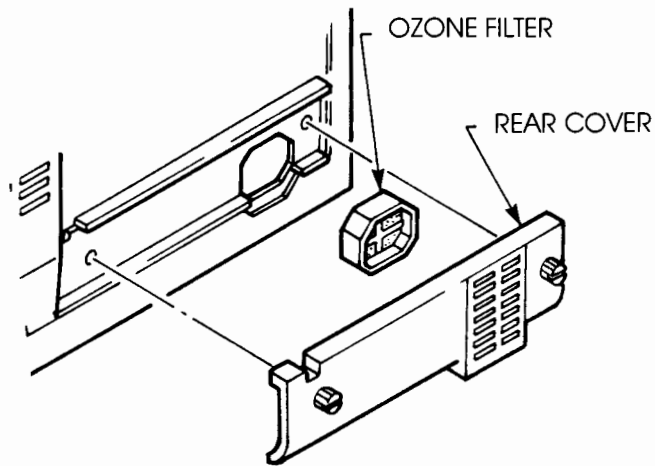

Figure 4-15. Removing Rear Cover

**CAUTION**

Handle the ozone filter by the black plastic rim; avoid touching the filter itself.

- b. Replace the ozone filter (figure 4-16).

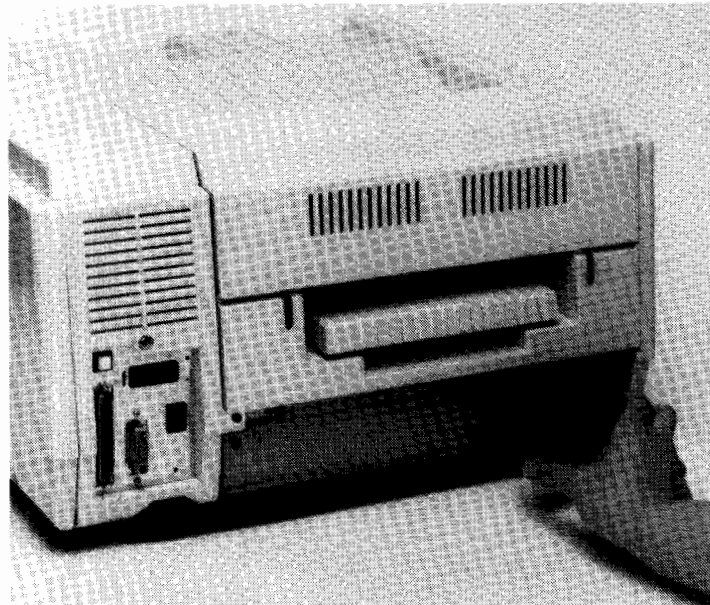

Figure 4-16. Replacing Ozone Filter

2688A

## OPC BELT REPLACEMENT

**CAUTION**

Do not use any cleaning fluids such as head cleaner to clean the OPC belt because they contain oil and will cause damage.



The OPC belt degrades with use and should be replaced every 20,000 pages (see page counter) or when it is scratched or soiled. If the OPC belt is soiled, it can usually be cleaned with a soft cloth using isopropyl alcohol. When cleaning the OPC belt, avoid exposing the belt to light for prolonged periods of time--the OPC belt is light sensitive and should only be exposed to light long enough for it to be cleaned and re-inserted into the printer. If it is necessary to keep the belt out of the printer for very long, cover the belt with a piece of clean paper until you are ready to place it back into the printer.

To replace the OPC belt proceed as follows:

- a. Pull outward on the development drawer until it locks.
- b. Remove the development unit by pushing down the green unlocking lever and then pulling out the development unit (figure 4-17).
- c. Remove the paper tray as shown in figure 4-18 and set it aside.
- d. Remove the paper feed guide plate as shown in figure 4-19 and clean it with a dry soft cloth.



# 2688A

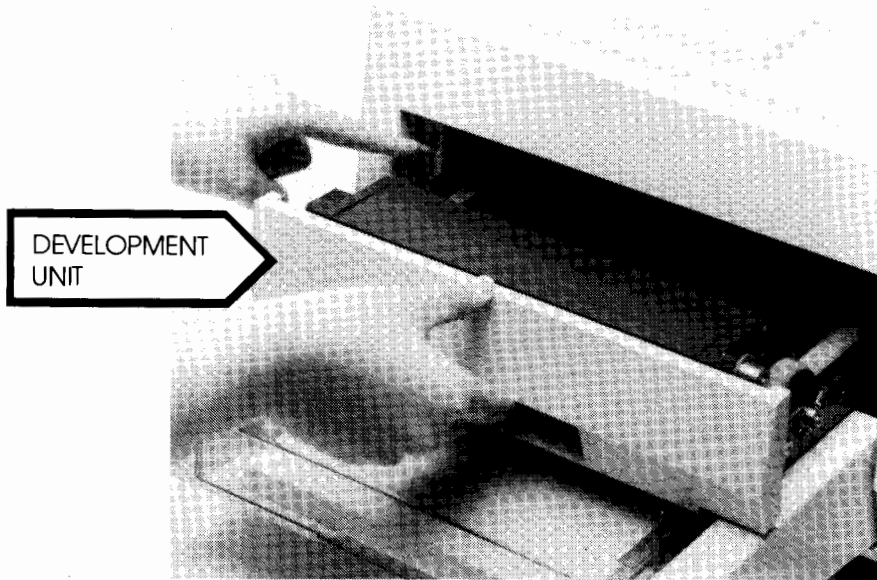

Figure 4-17. Removing Development Unit

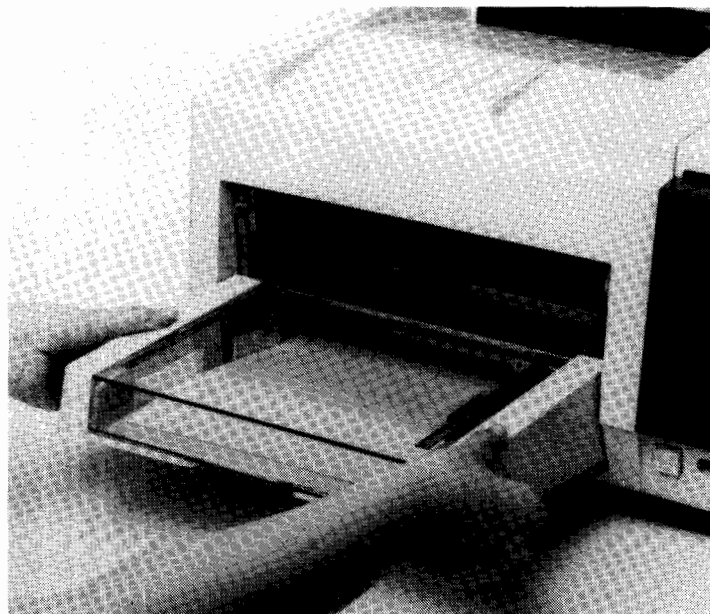

Figure 4-18. Removing Paper Tray

26884

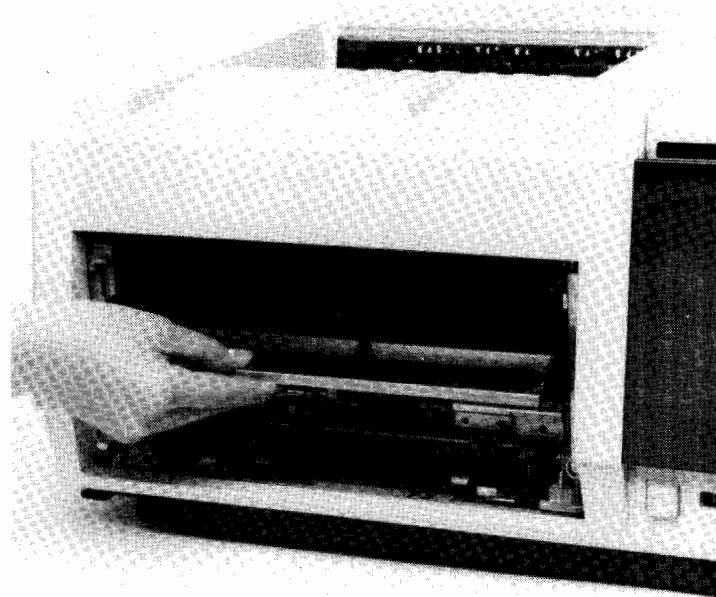

Figure 4-19. Removing Paper Feed Guide Plate

- e. Using only your fingers, lift and remove the OPC belt cassette from the development unit by holding the green handles located on both sides of the cassette (figure 4-20).
- f. Set the OPC cassette down on a non-abrasive surface and clean the OPC cassette receptacle with a soft dry cloth to remove any toner or particles (see figure 4-21).

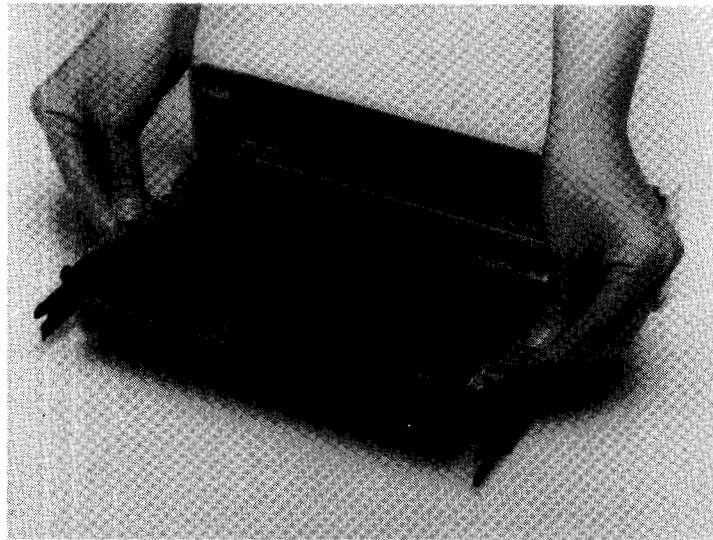

Figure 4-20. Removing OPC Belt Cassette

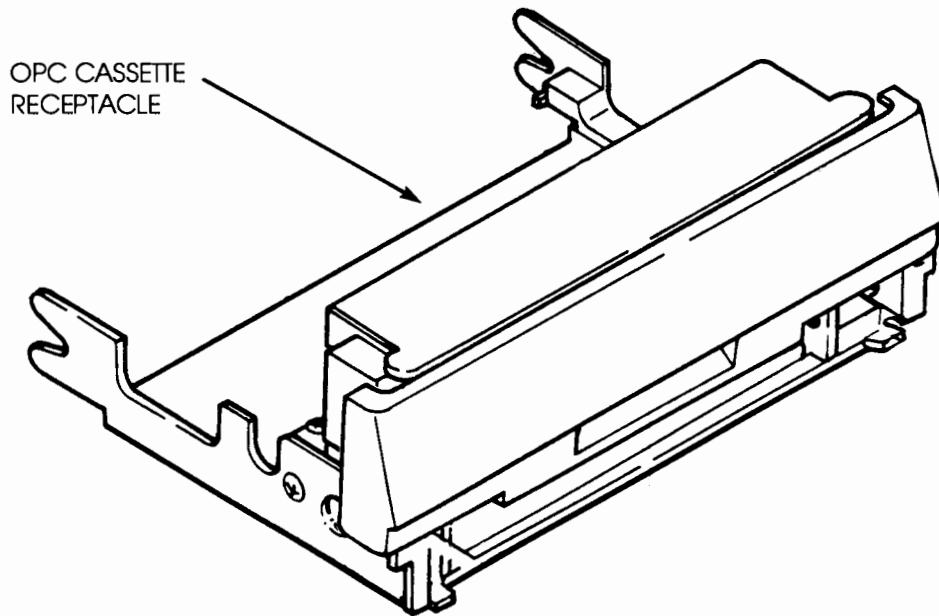

Figure 4-21. Cleaning OPC Cassette Receptacle

- g. Remove the dust-proof cover from the development unit.

# 2688A

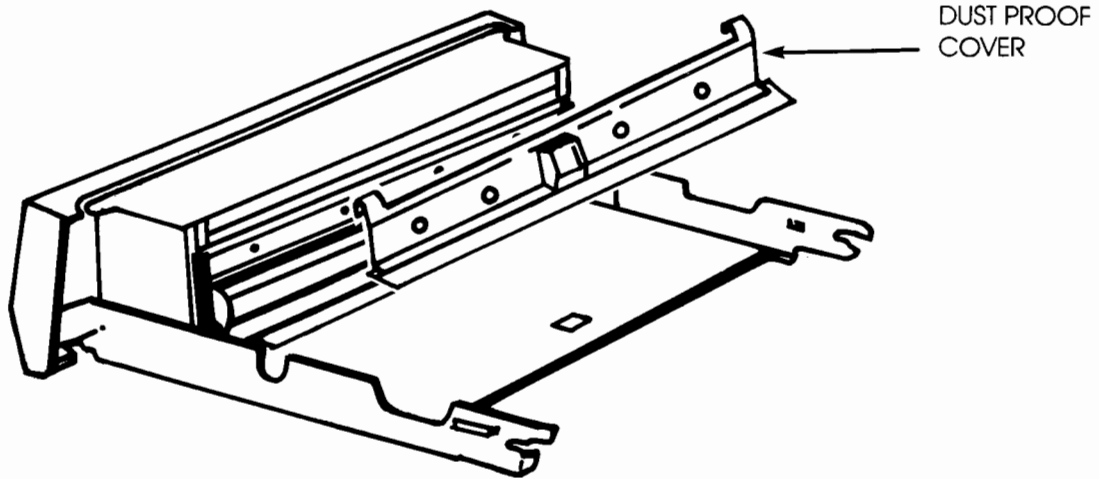

Figure 4-22. Removing Dust-Proof Cover

- h. Wipe the dust-proof cover with a dry cloth and place it back on the development unit (see figure 4-22).
- i. Move the levers on both sides of the OPC cassette to the unlock position to release tension in the OPC belt (figure 4-23).

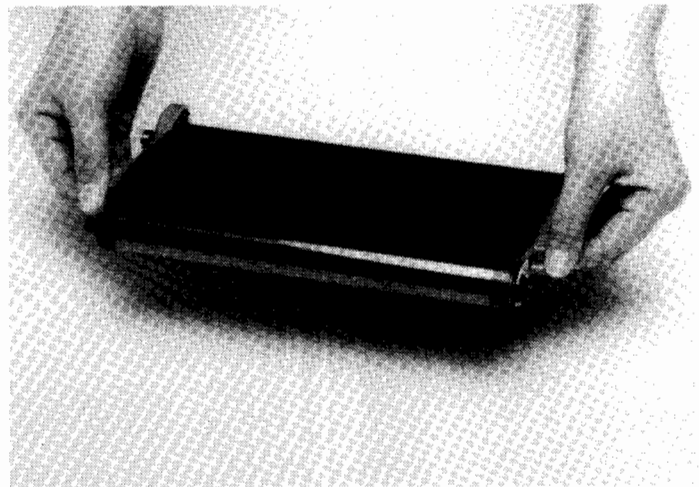
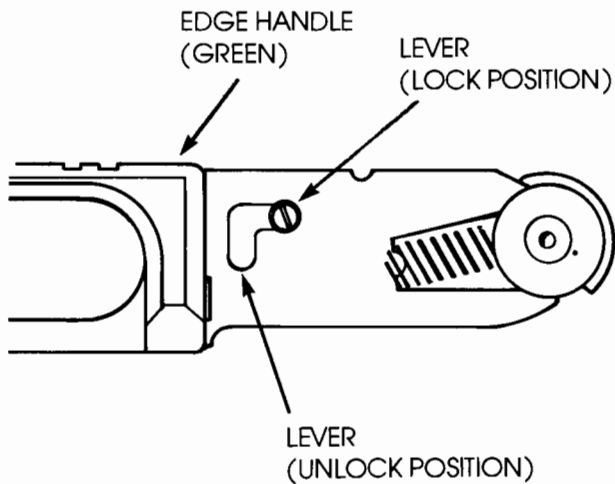

Figure 4-23. Unlocking OPC Belt Tension Levers

26884

- j. Remove the OPC belt by pulling in it the direction shown by the arrow (figure 4-24).

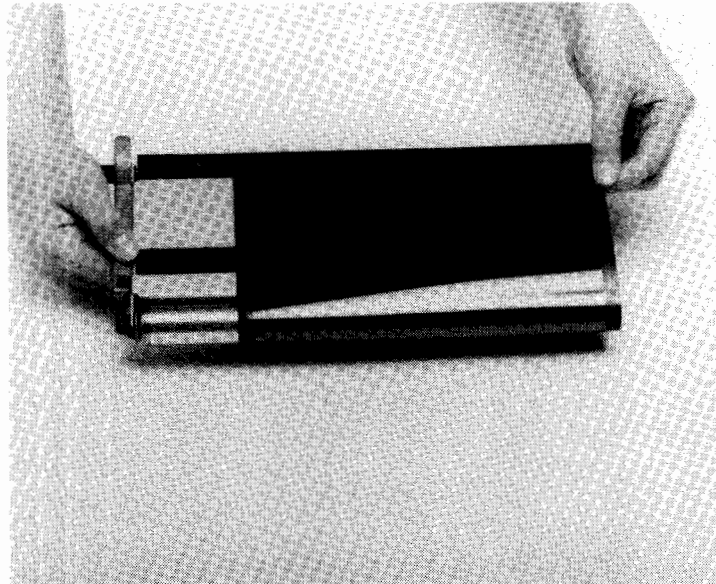

Figure 4-24. Removing OPC Belt

**CAUTION**

Do not remove the protective cover from the new OPC belt before it is installed on the OPC cassette.

**26884**

- k. Slide a new OPC belt, with the arrow mark located on the right-hand side (see figure 4-25), until the edge of the OPC belt is 1/8 inch from the green edge-handle on the right-hand side. The OPC belt should be centered on the rollers when installed properly.

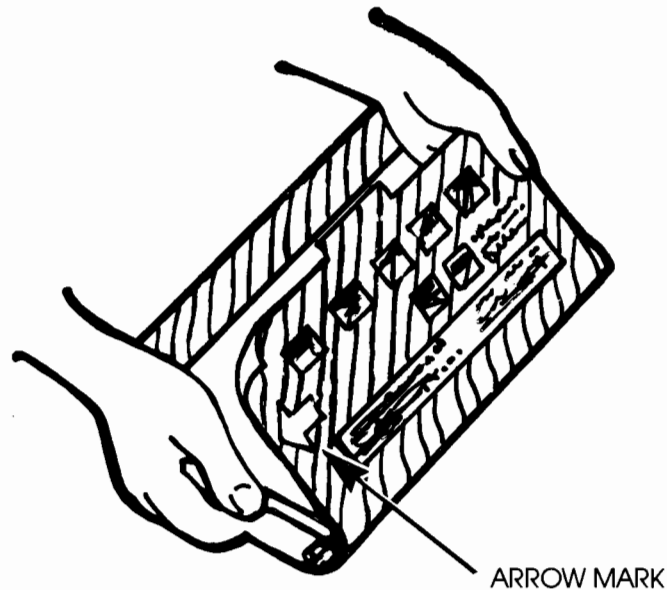

Figure 4-25. Installing New OPC Belt

- l. Move the levers on both sides of the OPC cassette to the locked position to apply tension to the OPC belt.
- m. Remove the protective sheet from the OPC belt and check to see that the synchronizing mark on the OPC belt is on the opposite side from the drive gear (see figure 4-26). If the mark is on the wrong side, re-install the OPC belt so that the mark is on the opposite side.

2688A

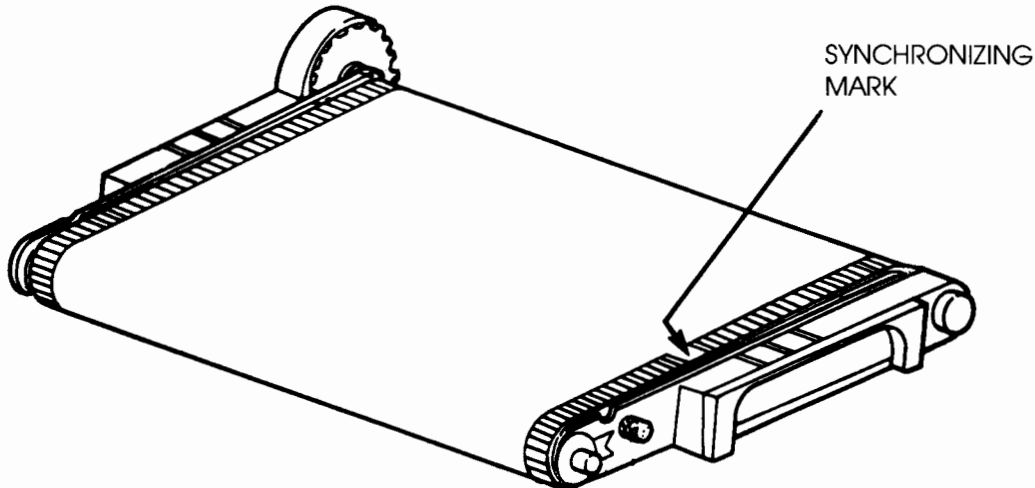

Figure 4-26. Checking the Synchronizing Mark

- n. Place the OPC belt cassette on the development unit.
- o. Place the clean paper feed guide plate into the printer.
- p. Place the paper tray back into the printer.
- q. Slide the development unit back into the printer. Be sure the drawer is completely pushed in.
- r. Verify that the "Close Cover" indicator on the Operator Guide Panel extinguishes. This indicates that the development drawer is back in the proper position.

## SENSOR AND SECOND CYLINDRICAL LENS CLEANING

The second cylindrical lens and the OPC and paper-out sensors should be cleaned every 20,000 pages (check printer's page counter). There are also other times when these items should be cleaned. The OPC sensor should be cleaned if false no-OPC belt indications are occurring. The paper-out sensor should be cleaned when false paper-out indications are occurring. Clean the second cylindrical lens if background toner begins to appear on the printed paper.

Perform the following steps to clean the OPC sensor, second cylindrical lens, and paper-out sensor:

- a. Pull out the development unit until it locks.
- b. Remove the development unit by pushing down the green unlocking lever and pulling out the development unit (figure 4-27).

# 2688A

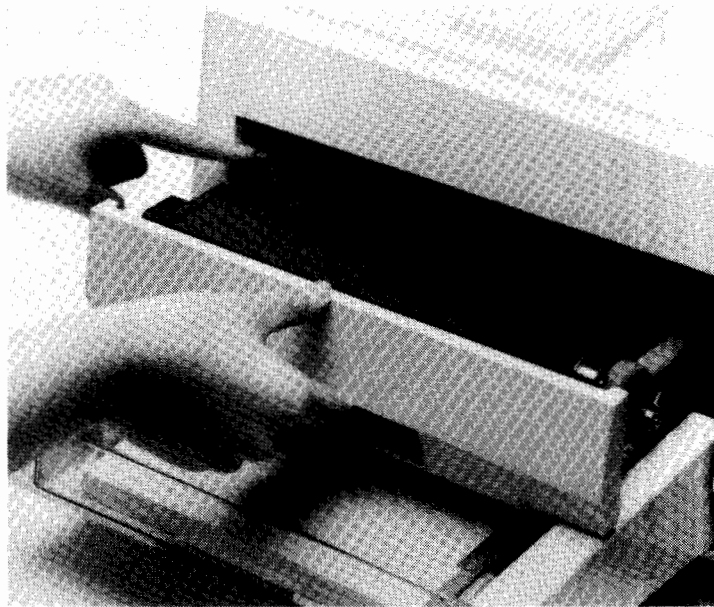

Figure 4-27. Removing Development Unit

- c. With your finger, release the latches which hold the second cylindrical lens cover and remove the cover (see figure 4-28).

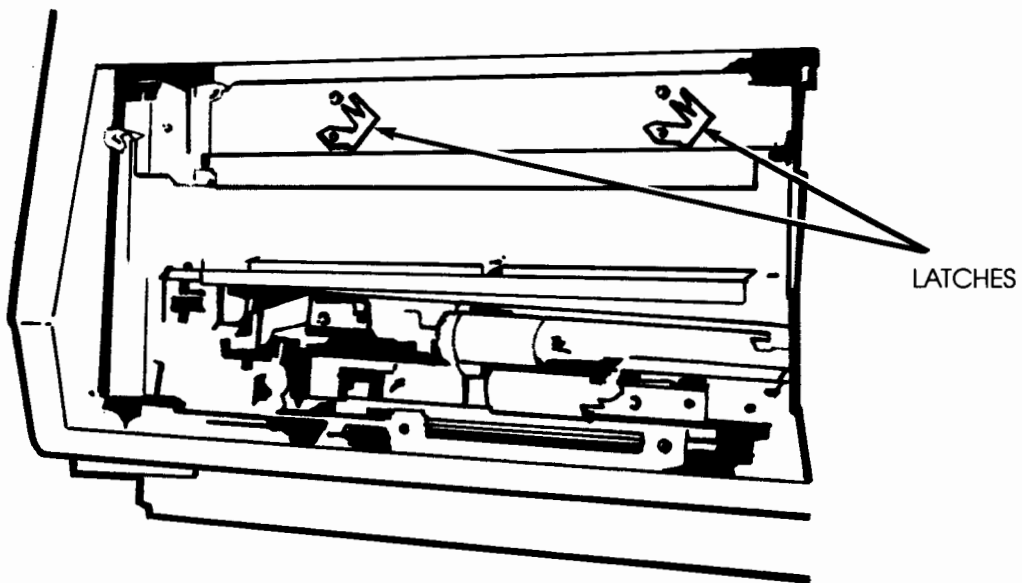
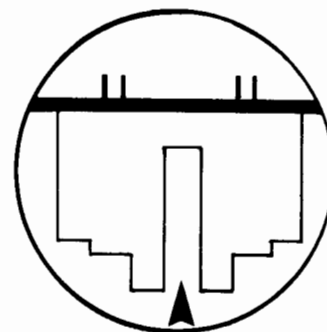
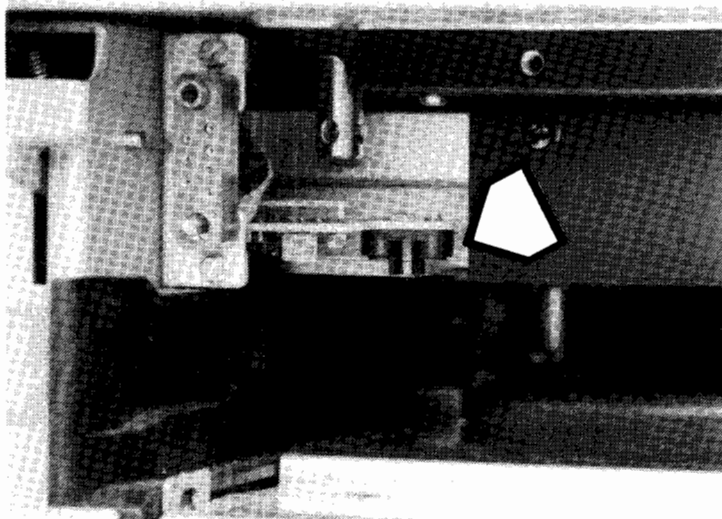

Figure 4-28. Removing Lens Cover



- d. Wipe the OPC sensor with a soft dry cloth as shown in figure 4-29.



WIPE INSIDE  
OPC SENSOR  
WITH DRY CLOTH

Figure 4-29. OPC Sensor Cleaning

**CAUTION**

To prevent scratches on the lens, use only lens cleaning paper.

- e. Clean the second cylindrical lens with lens cleaning paper (figure 4-30).

# 2688A

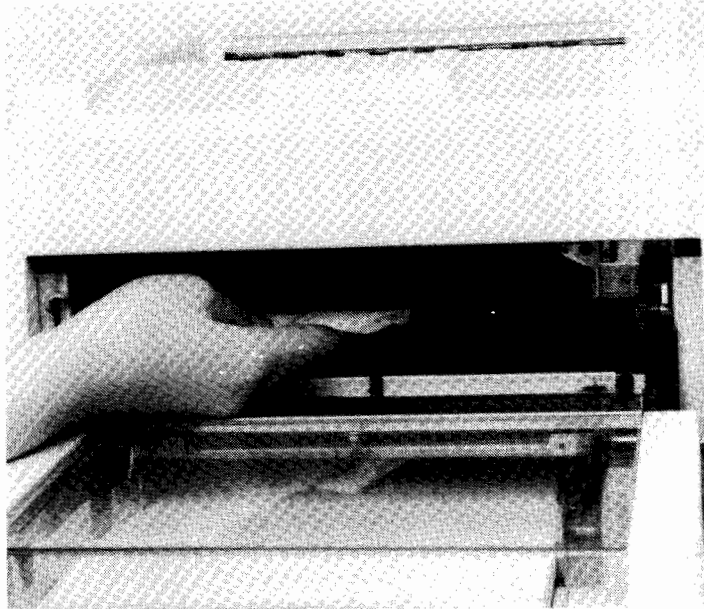

Figure 4-30. Lens Cleaning

- f. Wipe the second cylindrical lens cover clean with a soft dry cloth and place it back onto the printer.
- g. Remove the paper tray as shown in figure 4-31.
- h. Clean the paper-out sensor by wiping it with a dry cloth as shown in figure 4-32.

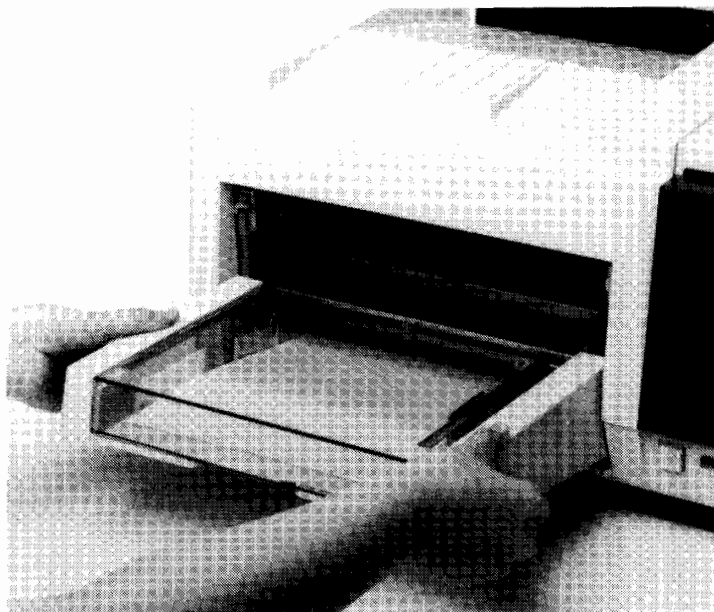
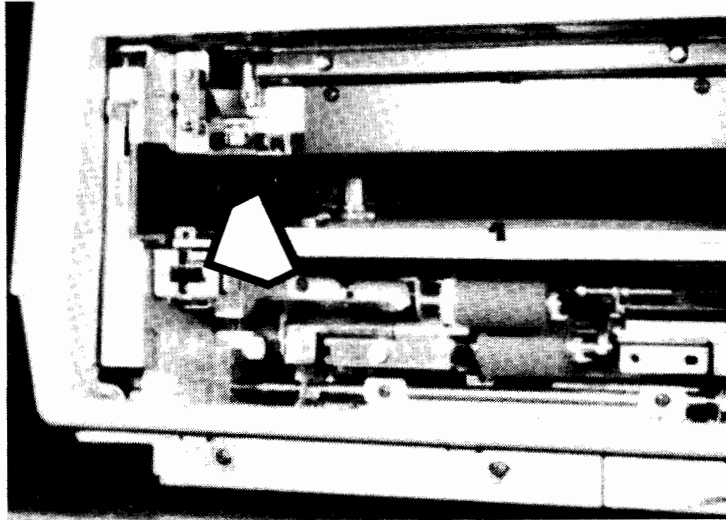

Figure 4-31. Removing the Paper Tray

26884



WIPE CLEAN  
WITH DRY CLOTH

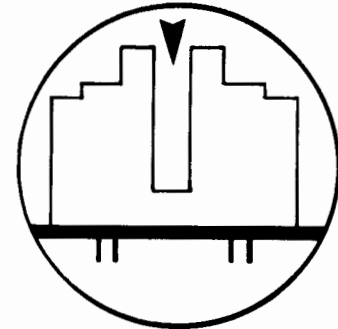

Figure 4-32. Paper-Out Sensor Cleaning

- h. Replace the development unit removed in step b. Be sure the drawer is completely pushed in.
- i. Replace the paper tray removed in step g.

**26884**

# SECTION V. IN CASE OF DIFFICULTY

## INTRODUCTION

There are several instances in which proper operator action can correct printer difficulties. To expedite the correction of these difficulties, the operator should be aware of the information and suggestions listed in this section of the manual. The following topics are discussed in this section:

Paper Jams

Service Required Indicator

Operator Hints

Self Test

Reset

## PAPER JAMS



When paper will not feed or there is a paper misfeed, the paper path indicator flashes and the printer stops. First, observe the monitor indicator on the Operator Guide Panel (see figure 5-1) and identify the position at which the paper has stopped. Then perform one of the following steps.

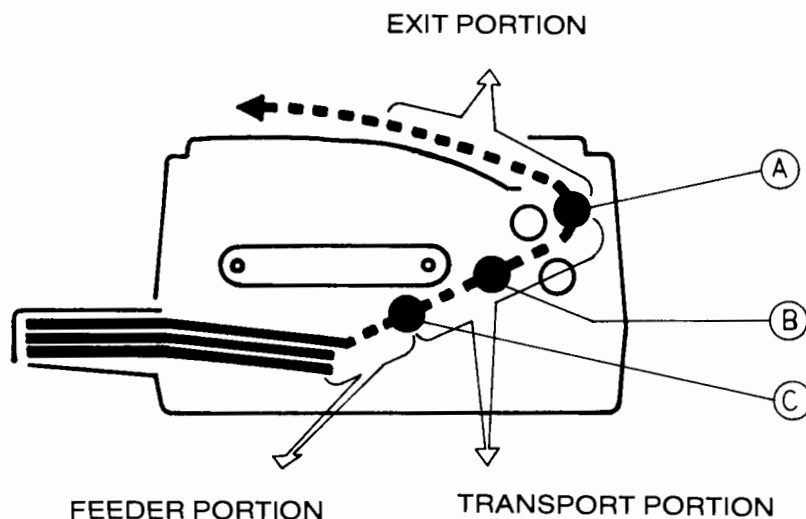

Figure 5-1. Monitor Indicator

**IF THE INDICATOR AT POINT (A) ILLUMINATES, CHECK THE PAPER EXIT UNIT AND FUSING UNIT AS FOLLOWS:**

- a. Pull out the paper exit unit horizontally while lifting up the fusing drawer lever (see figure 5-2).

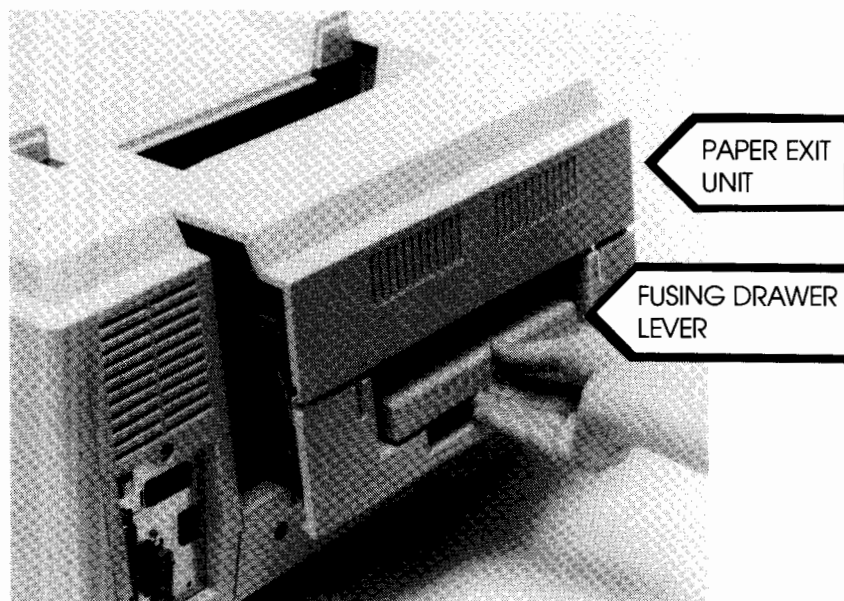

Figure 5-2. Opening Paper Exit Unit

- b. Open the paper exit cover (figure 5-3).

26884

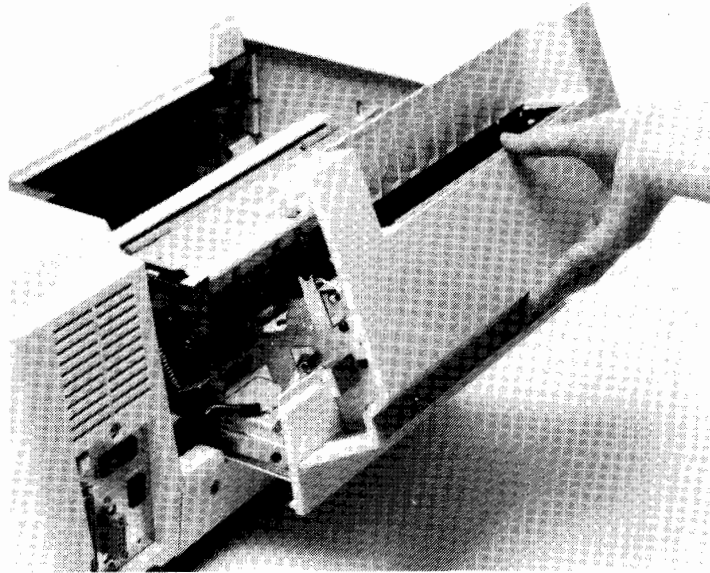

Figure 5-3. Opening Paper Exit Cover

- c. Remove the misfed paper (figure 5-4). If no paper is found or the trailing edge of the paper is in the fusing unit, follow the procedures described below.

**WARNING**

The fusing unit is extremely hot. Allow the machine to be completely off for 40 minutes before touching it.

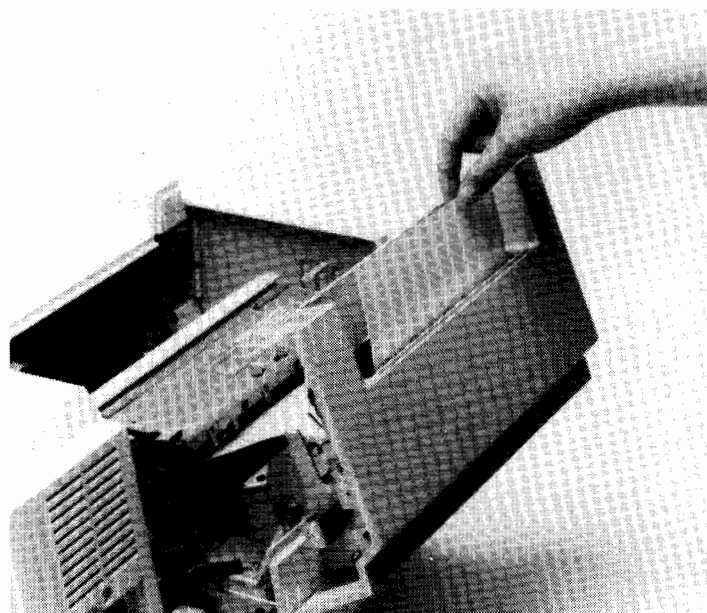

Figure 5-4. Removing Misfed Paper

- d. Release pressure in the fusing unit by moving the orange pressure lever on the fusing unit in the direction of the arrow (figure 5-5).

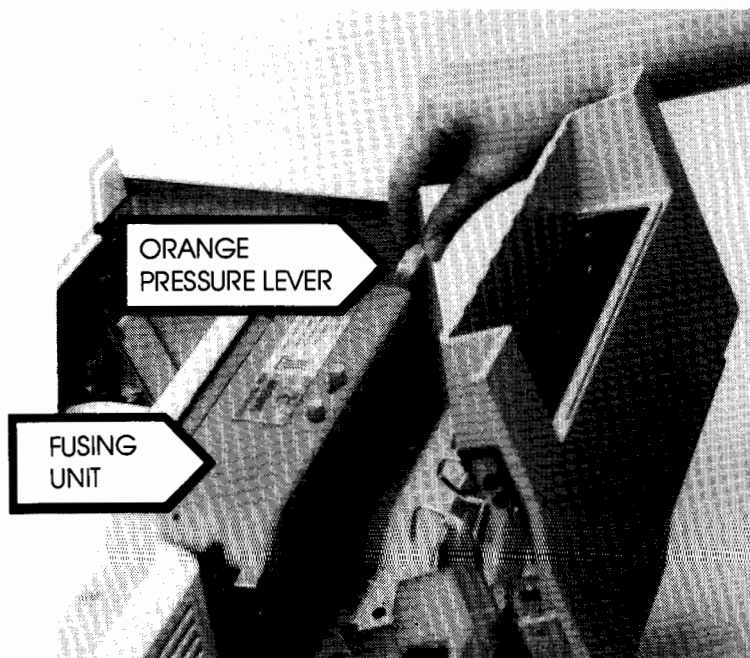

Figure 5-5. Releasing Fusing Unit Pressure

- e. Open the fusing cover by pushing the orange cover knobs inward as shown by the arrows (figure 5-6) and lifting up on the cover.

**26884**

Figure 5-6. Opening Fuser Cover

**WARNING**

The fusing unit is extremely hot. Allow the machine to be completely off for 40 minutes before touching it.

- f. Remove the misfed paper with extreme care so that no torn pieces remain in the fusing unit (figure 5-7).

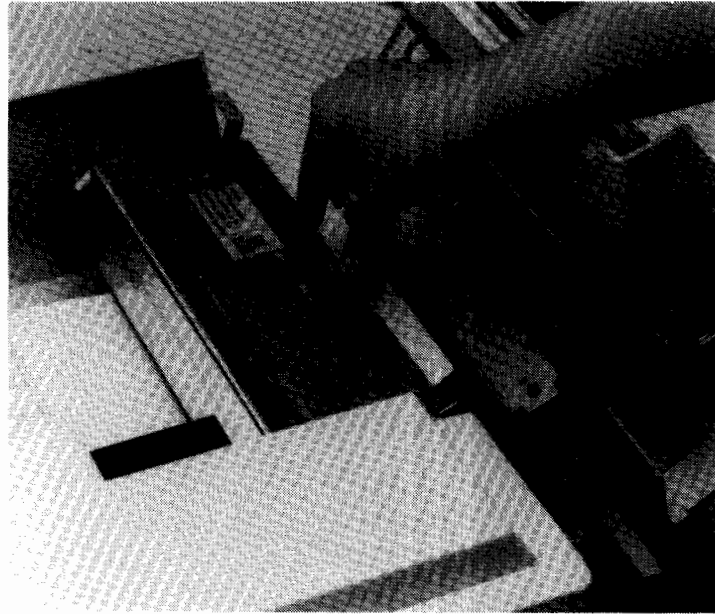
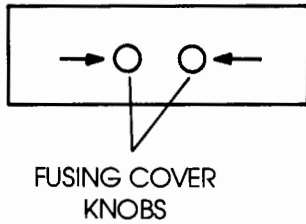

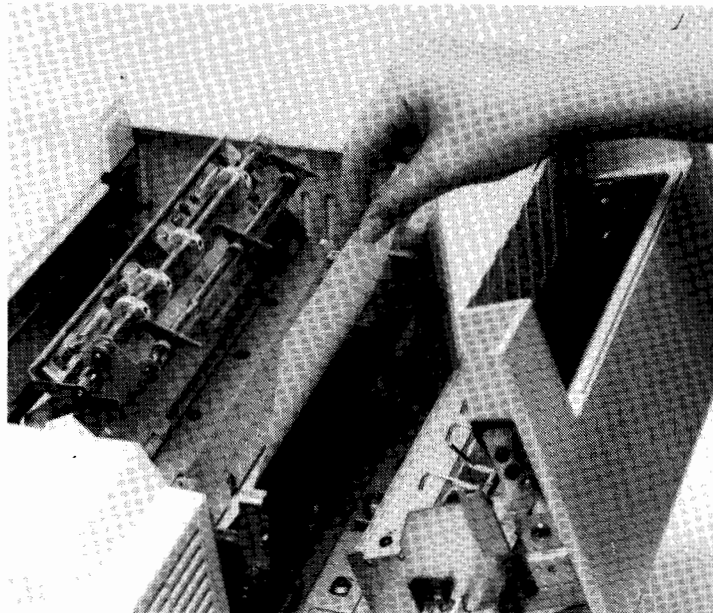

Figure 5-7. Removing Misfed Paper

- g. Clean the 3 separation pawls. Toner builds up on the tips of the pawls and can easily be cleaned by chipping it off lightly with your fingernails (see figure 5-8).

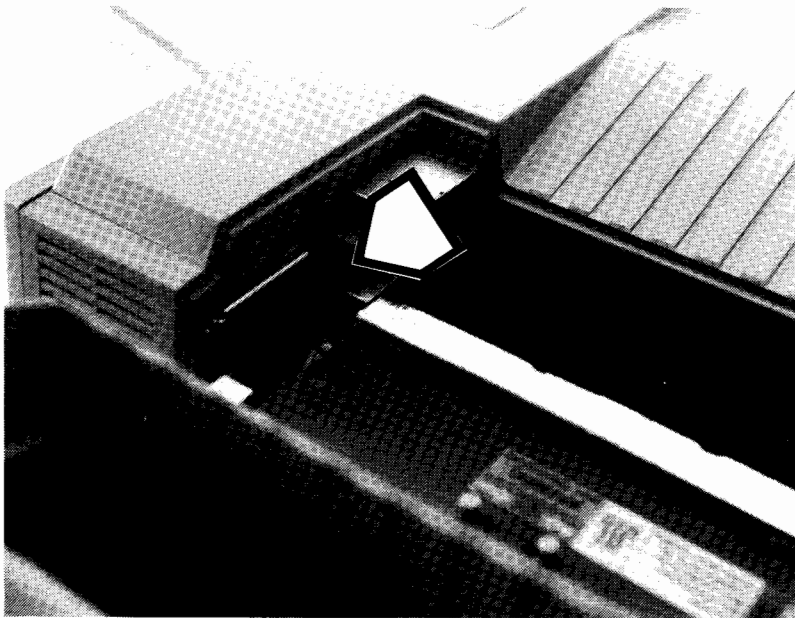

Figure 5-8. Cleaning Separation Pawls

- h. Close the fusing cover while pushing the cover knobs inward.

2688A

- i. Return the pressure lever to the original position.
- j. Wipe the paper exit sensor clean with a dry cloth as shown in figure 5-9.



WIPE CLEAN  
WITH SOFT, DRY  
CLOTH

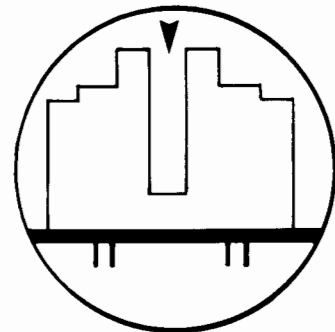

Figure 5-9. Cleaning Paper Exit Sensor

- k. Close the paper exit cover.

**IF THE INDICATOR AT POINT (B) ILLUMINATES, CHECK THE TRANSPORT PORTION AS FOLLOWS:**

- a. Pull out the paper exit unit horizontally while lifting up the fusing drawer lever (figure 5-10).

**WARNING**

The fusing unit is extremely hot. Allow the machine to be completely off for 40 minutes before touching it.

2688A

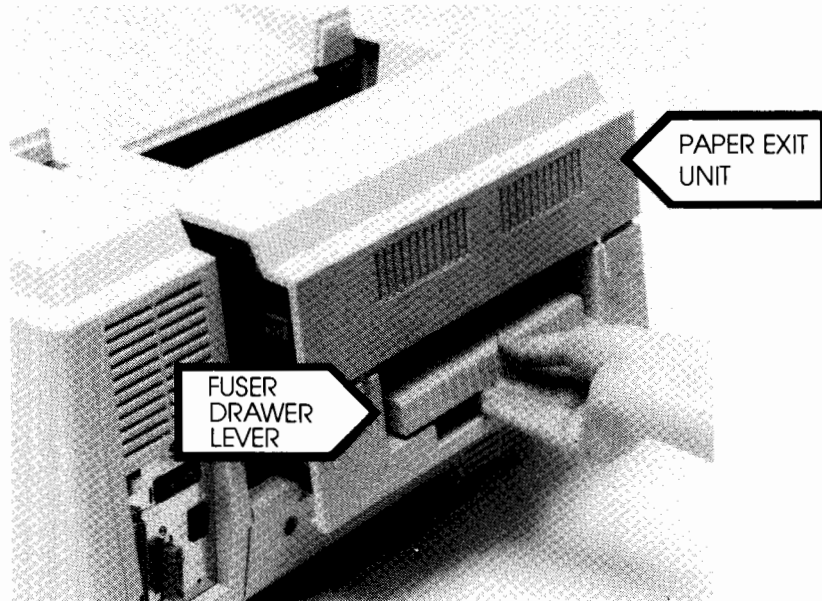

Figure 5-10. Pulling Out Paper Exit Unit

- b. If the leading edge of the paper is seen, grasp this leading edge and gently pull it out. If the leading edge of the paper can not be seen, pull out the development drawer to the locking position (refer to figure 4-4) and then remove the paper (figure 5-11).

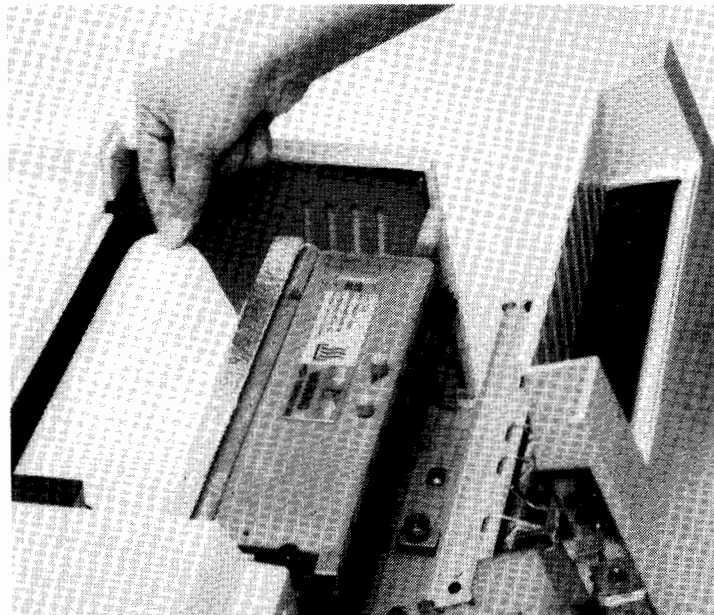

Figure 5-11. Removing Paper

**2688A****IF THE LEADING EDGE OF THE PAPER IS IN THE FUSING UNIT:**

- c. Open the paper exit cover (figure 5-12).

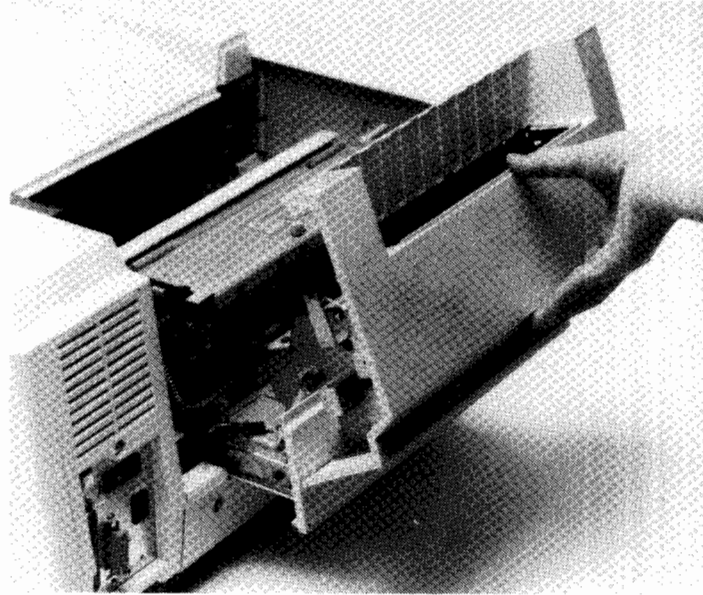

Figure 5-12. Opening Paper Exit Cover

- d. Release the pressure in the fusing unit by pushing the pressure lever of the fusing unit in the direction shown by the arrow (figure 5-13).

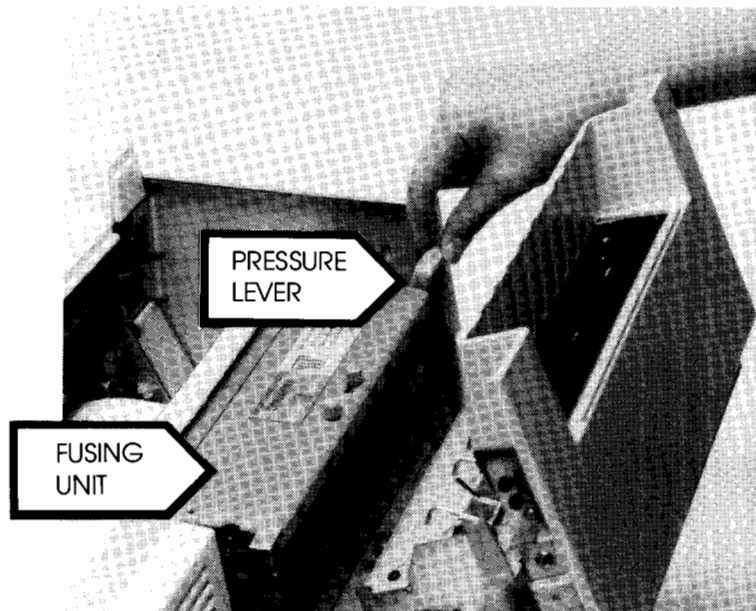

Figure 5-13. Releasing Fuser Unit Pressure

- e. Take the paper out with extreme care so that no torn pieces of paper remain in the fusing unit (see figure 5-14).

**WARNING**

The fusing unit is extremely hot. Do not touch it with your hand.

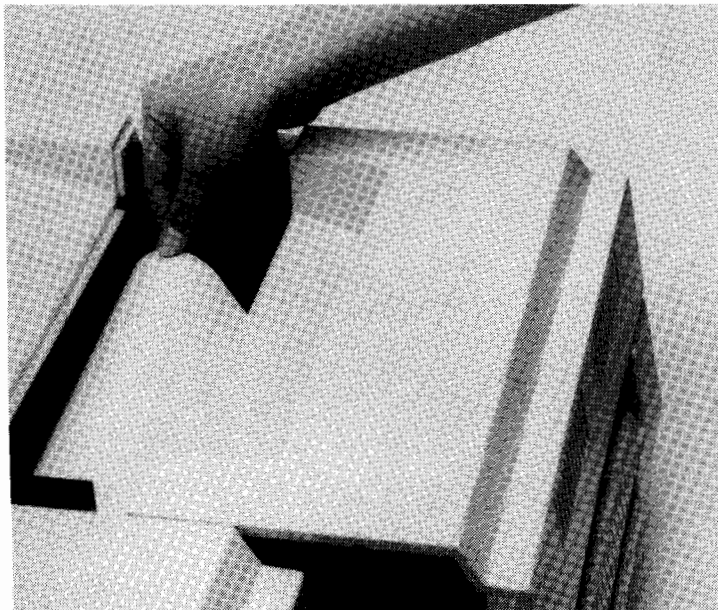

Figure 5-14. Removing Paper

- f. Set the pressure lever back to the original position.
- g. Close the paper exit cover.
- h. Push in the paper exit unit while lifting up the fusing drawer lever. Make sure the "Close Cover" indicator on the Operator Guide Panel is not illuminated.

**IF THE INDICATOR AT POINT (C) ILLUMINATES, CHECK THE FEEDER PORTION AS FOLLOWS:**

- a. Open the paper tray cover (figure 5-15).

26884

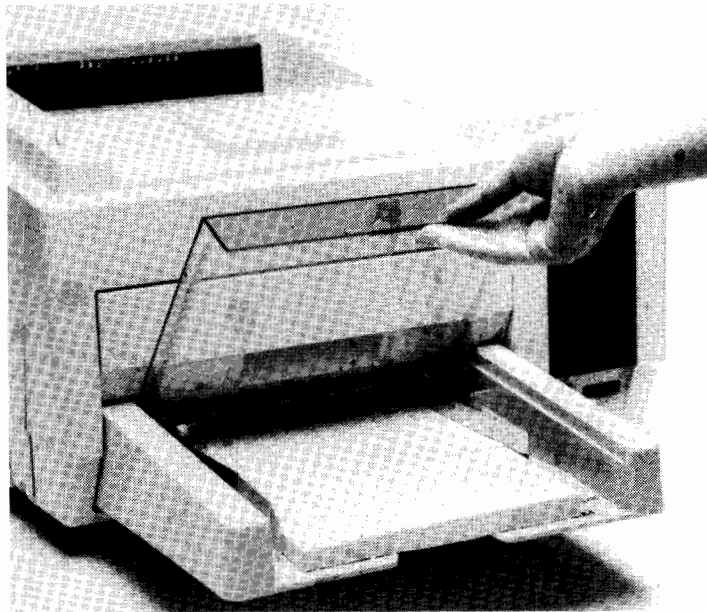

Figure 5-15. Opening Paper Tray Cover

b. If the paper is misfed here, remove this paper (figure 5-16).

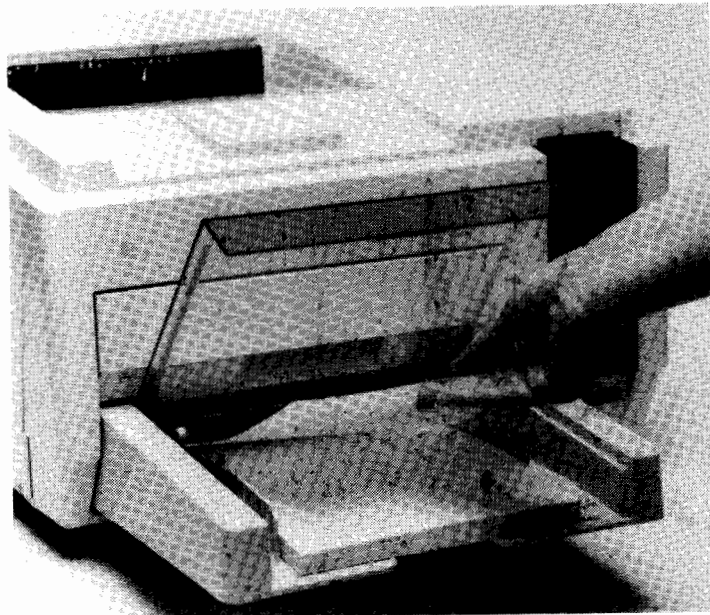

Figure 5-16. Removing Misfed Paper

c. Close the paper tray cover.

26884

## SERVICE REQUIRED INDICATOR



The Service Required indicator, located on the Operator Guide Panel, flashes to indicate a fault condition exists in the printer. The location of this fault can be identified from the alphanumeric indicator located to the right of the service-man symbol.

When the "Service Required" indicator on the Operator Guide Panel flashes, turn the Main Power switch OFF, then back ON. When the alphanumeric Indicator next to the service man symbol displays a number other than "4", contact your Hewlett-Packard Sales and Service Office and inform them of the nature of the problem and the alphanumeric value displayed. If the number "4" is displayed, carry out the following procedure:

- a. Replace the OPC belt. Refer to the OPC Belt Replacement procedure in section IV of this manual.
- b. Clean the OPC sensor. Refer to the section on Sensor and Second Cylindrical Lens Cleaning in section IV of this manual.

If the Service Required indicator still flashes after taking the remedial action described, contact the nearest Hewlett-Packard Sales and Service Office.

TABLE 5-1. SERVICE REQUIRED INDICATOR

Alphanumeric Value	Abnormal Condition
1.	Fusing system error
2.	Main scanning error (optical system error)
3.	Number of 1 and 2 errors
4.	Synchronizing mark error
5.	Number of 1 and 4 errors
6.	Number of 2 and 4 errors
7.	Number of 1, 2, and 4 errors
8.	Timing pulse error (pulse generator error)
9.	Number of 1 and 8 errors
A.	Number of 2 and 8 errors
B.	Number of 1, 2, and 8 errors
C.	A synchronizing mark error (No. 4) occurring
D.	together with a timing pulse error (No. 8)
E.	is very unlikely; therefore, the remaining
F.	values (C - F) are not used.

# 26884

## OPERATOR HINTS

When the following fault conditions occur, try to remedy the problem with the operator procedures described as follows:

**Fault Condition**

**Operator Action**

**No display on the Operator Guide Panel after the Main Power switch is turned ON.**

Check to see if the power cord is disconnected from the power outlet. (Reconnect the plug securely to the power outlet.)

**"Printer Ready/Busy" Indicator does not turn green (from flashing red) after a 90-second warm-up period.**



a. Check to see if the "Add Paper" indicator is flashing. (If it is, refer to the Paper Loading Section of this manual.)



b. Check to see if the "Paper Path" indicator is flashing. (If it is, refer to the Paper Jam section of this manual.)

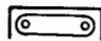

c. Check to see if the "Set OPC Belt" indicator is flashing. (If it is, refer to the OPC Belt Replacement section of this manual.)



d. Check to see if the "Change Toner Disposal Bottle" indicator is flashing. (If it is, refer to the Disposal Bottle Replacement section of this manual.)



e. Check to see if the "Close Cover" indicator is flashing. (If it is, refer to the Operator Guide Panel Description.)



f. Check to see if the "Service Required" indicator is flashing. (If it is, refer to the Service Required Indicator section of this manual.)



g. If the "Printer Ready/Busy" indicator stays red and none of the above indicators are flashing, turn the Main Power switch OFF and then back ON.

**The machine stops during printing.**



a. Check to see if the "Add Paper" indicator



2688A

is flashing. (If it is, refer to the Paper Loading section of this manual.)



b. Check to see if the "Check Paper Path" indicator is flashing. (If it is, refer to the Paper Jam section of this manual.)



c. Check to see if the "Close Cover" indicator is flashing. (If it is, refer to the Operator Guide Panel description.)

d. Check to see if Print Stop was requested by the host system during continuous printing. (When Print Stop is requested during continuous printing, the machine prints the current page, then stops.)

**The surface of the printed paper is dirty.**

a. Check to see that the Fuser Cleaning Pad is not contaminated with toner. (If it is dirty, refer to the Fuser Cleaning Pad Replacement section.)

b. Change the OPC belt. (Refer to the OPC Belt Replacement section.)

c. Clean the Second Cylindrical Lens. (Refer to the Second Cylindrical Lens Cleaning section.)

d. Check to see if the Corona Wires are contaminated with toner. (Refer to the Corona Cleaning section.)

e. Replace the paper pack with a new one. (Refer to the Paper Loading section.)

**Printed characters are not clearly discernible (i.e. not dark enough).**



a. Check to see if the "Add Toner" indicator is flashing. (If it is, refer to the Adding Toner section.)

b. Check to see if the Corona Wires are contaminated with toner. (Refer to the Corona Cleaning Section.)

c. Replace the OPC belt. (Refer to the OPC Belt Replacement section.)

d. Replace the paper in the tray with a new one. (Refer to the Paper Loading section.)

2688A

No paper is fed into the machine, or several sheets are fed into the machine at once.

a. Replace the paper in the tray with new paper. (Refer to the Paper Loading section.)

You detect an ozone smell

a. Replace the ozone filter. (Refer to the Ozone Filter Replacement section.)



## SELF TEST

To check the operation of the HP 2688A, both the printer and the controller have their own self-test functions. The self-tests exercise various functions of the printer and controller and indicate whether or not they are running normally.

When the printer is off-line, pressing the TEST button on the back of the printer (figure 5-17) causes the dot pattern test printout to be printed as shown in figure 5-18. The machine is operating normally when the dots are clearly discernible and the "Service Required" indicator on the Operator Guide Panel does not flash. The printer self-test will continue to run until the TEST button is pressed again (once).

### NOTE

Before performing the controller self-test, disconnect the HP-IB cable from the system.

Pressing the TEST button on the back of the HP 26088 Controller (with the printer on-line) causes the printer to print a test pattern as shown in figure 5-19. Once the self-test is initiated, the green indicator LED located on the front of the controller should be illuminated and then should extinguish after 1 second. The green indicator LED will remain off until either the self-test is completed or an error occurs. If the LED illuminates and remains on, then the controller has passed self-test. If the self-test fails, the green LED will blink on and off to advise the operator of the failure.

If the self-tests do not print properly, the "Service Required" indicator flashes, or the controller's green indicator LED flashes, consult the Operator Hints portion of this manual. If you still cannot correct the problem, call your HP Service Representative.

26884

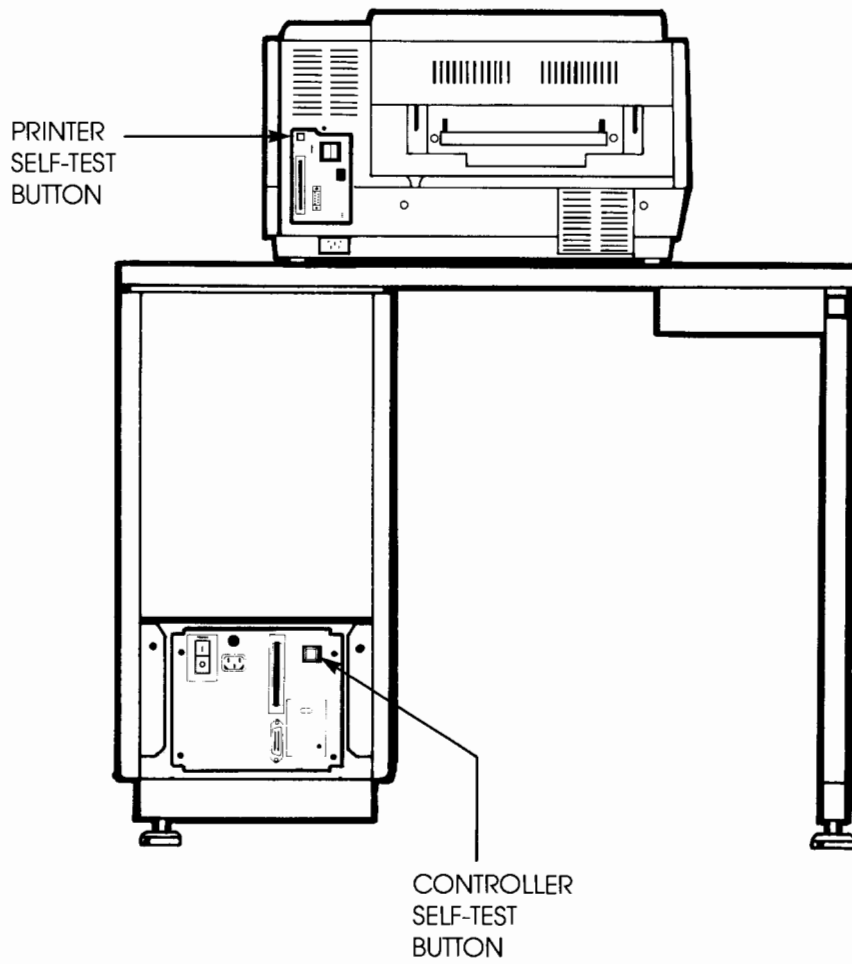

Figure 5-17. Printer and Controller Self Test Switches



2688A