

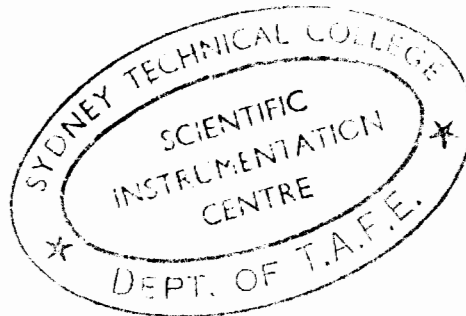

OPERATOR'S MANUAL
2613A/2617A/2618A
LINE PRINTER DIAGNOSTIC
(For 2100-Series Computers)

Binary Tape Series: 1633



HP Computer Museum
www.hpmuseum.net

For research and education purposes only.

TABLE OF CONTENTS

Section I

INTRODUCTION

General.....	1-1
Required Hardware.....	1-1
Required Software.....	1-1

Section II

PROGRAM ORGANIZATION

Organization.....	2-1
Test Control and Execution.....	2-1
Selection of Tests by Operator.....	2-1
Message Reporting.....	2-1
Diagnostic Limitations.....	2-2

Section III

OPERATING PROCEDURE

Operating Procedures.....	3-1
Operating Procedure Flowchart (Figure 3-1).....	3-2
Running the Diagnostic.....	3-3
Test Selection by Operator.....	3-3
Restarting.....	3-4

Section IV

DIAGNOSTIC PERFORMANCE

Test Description.....	4-1
Basic I/O Test.....	4-1
Manual Control Test.....	4-3
Ripple Print Test.....	4-4
Triangular Print Test.....	4-4
Vertical Format Control Test.....	4-5
Character Set Test.....	4-6
Over Print & Buffer Over Lay Test.....	4-6
DMA Test.....	4-7
Operator Design	4-7
Error Information Messages/Halt Codes	4-7

APPENDIX

Operator Design Instruction.....	A-1
Instruction Format.....	A-3
Executing the OP Design Program.....	A-4
OP Design Message	A-4
Test Program Examples.....	A-5

LIST OF ILLUSTRATIONS

OPERATING PROCEDURES

Operating Procedure Flowchart.....	3-2
Example OP Design Program Flowchart	A-5
Example 1 Test Printout.....	A-6

LIST OF TABLES

Test Selection Summary.....	3-2
Switch Register Settings.....	3-4
Halt Code Summary.....	4-7
Error Information Messages and Halt Codes.....	4-8
Line Printer Status Word.....	4-15
Line Printer Command Word.....	4-16

Section I

INTRODUCTION

1-1. GENERAL

This diagnostic checks the operation of the HP 2613A, 2617A, or 2618A Line Printers and the HP 12845B Interface. The basic I/O portion of the interface, which includes the Flag and Control circuits, will be tested. The interface will be used with skip-on-flag, interrupt, and direct memory access (DMA). All operations except status and response time must be checked visually by the operator.

1-2. REQUIRED HARDWARE

The following hardware is required:

- a. HP 2100 series computer with a minum of 4K memory.
- b. HP 12845B interface (includes P/N 12845-60006 interface cable).
- c. HP 2613A, 2617A, or 2618A Line Printer.
- d. A paper tape reading device (used only for loading).
- e. A console teleprinter device (used for message reporting- recomended but not required).
- f. Two VFU test tapes as follows:
 - for 2613 and 2617 at 6 lpi, part no. 02613-80002.
 - for 2618 at 6lpi, part no. 02618-80002.
 - for 2613, 2617, and 2618 at 8 lpi, part no. 02618-80004.

1-3. REQUIRED SOFTWARE

The following software is required:

- a. Diagnostic configurator used for equipment configuration and as a console device driver. The configurator consists of:
 - Binary object tape, part no. 24296-60001
 - Manual, part no. 02100-90157
- b. HP 2613A/2617A/2618A Line Printer Diagnostic, binary object tape, part no. 02618-16001.

The diagnostic serial number (DSN) is contained in memory location 126_g of the program. The DSN is 145103_g.

Section II

PROGRAM ORGANIZATION

2-1. ORGANIZATION

This diagnostic program contains a control and initialization section and eight tests. The initialization and control section prepares the diagnostic by accepting the select code and option required by the tests.

2-2. TEST CONTROL AND EXECUTION

The program outputs a title message to the console device for operator information then executes the tests according to the options selected on the Switch Register by the operator. The control section mainly checks Switch Register bits 15, 13 and 12. Bit 12, if set, is used to loop on the diagnostic; bit 13 is used to loop on a given test that is running at the time; and bit 15, if set, will halt the computer at the completion of a test.

The program also keeps count of the number of passes that have been completed and will output the pass count at the completion of each pass (if Switch Register bit 10 is clear), the count will be reset only if the program is restarted.

Test sections are executed one after another in each diagnostic pass. User selection or default will determine which test sections will be executed. (Refer to paragraph 3-3.)

2-3. SELECTION OF TESTS BY OPERATOR

The operator has the capability to select his own test or sequence of tests with the help of bit 9 in the Switch Register. Paragraph 3-3 outlines the test selection.

2-4. MESSAGE REPORTING

There are two types of messages: error and information. Error messages are used to inform the operator when the interface fails to respond to a given control or sequence. Information messages are used to inform the operator of the progress of the diagnostic or to instruct the operator to perform some operation related to the function of the unit. In this case, an associated halt will occur to allow the operator time to perform the function. The operator must then press RUN. If a console device is used, the printed message will be preceded by the letter E (error) or the letter H (information) and a number (in octal). The number is also related to the halt code when a console device is not available. Examples of error and information messages are as follows:

Example - Error with halt

Message: E030 FLAG FAILED TO SET

Halt Code: 102030₈

Example - Information with halt

Message: H024 PRESS PRESET (EXT & INT), RUN

Halt Code: 102024₈

Example - Information only

Message: H025 BI-O COMP

Halt Code: None

Error messages can be suppressed by setting Switch Register bit 11 and error halts can be suppressed by setting Switch Register bit 14. This is useful when looping on a single section that has several errors. The A-register contains the actual status and the B-register contains the expected status when an error halt takes place.

Information messages are suppressed by setting Switch Register bit 10. Operator intervention is suppressed by setting Switch Register bit 8 (i.e., Preset Test in BI-O, Manual Control Test, and Operator Design Test). When Switch Register bit 12 is set the tests that are selected will be repeated. All operator intervention will be suppressed.

2-5. DIAGNOSTIC LIMITATIONS

2-6. PRIORITY STRING

The capability of the interface to receive, pass, and deny priority is not completely checked by this diagnostic. If the interface does not receive priority [i.e., PRH (Priority High) from next lower select code] an error E014 NO INT will occur. To check this, remove a board of a lower select code and run the Basic I/O Test and the above mentioned error should occur. Checking the ability of the board to pass or deny priority is beyond the scope of this diagnostic.

Section III
OPERATING PROCEDURE

3-1 OPERATING PROCEDURES

A flowchart of the operating procedures is provided on the following page.

Note: Before the Line Printer Diagnostic is executed,
either the 6 or 8 lines per inch VFU test tape
listed in paragraph 1-2f must be installed.

If an unconfigured Diagnostic Configurator is available start at entry point A.

If a configured Diagnostic Configurator is available start at entry point B.

If a combined configured Diagnostic Configurator and an unconfigured Diagnostic is available start at entry point C.

If a combined configured Diagnostic Configurator and a configured Diagnostic is available start at point D.

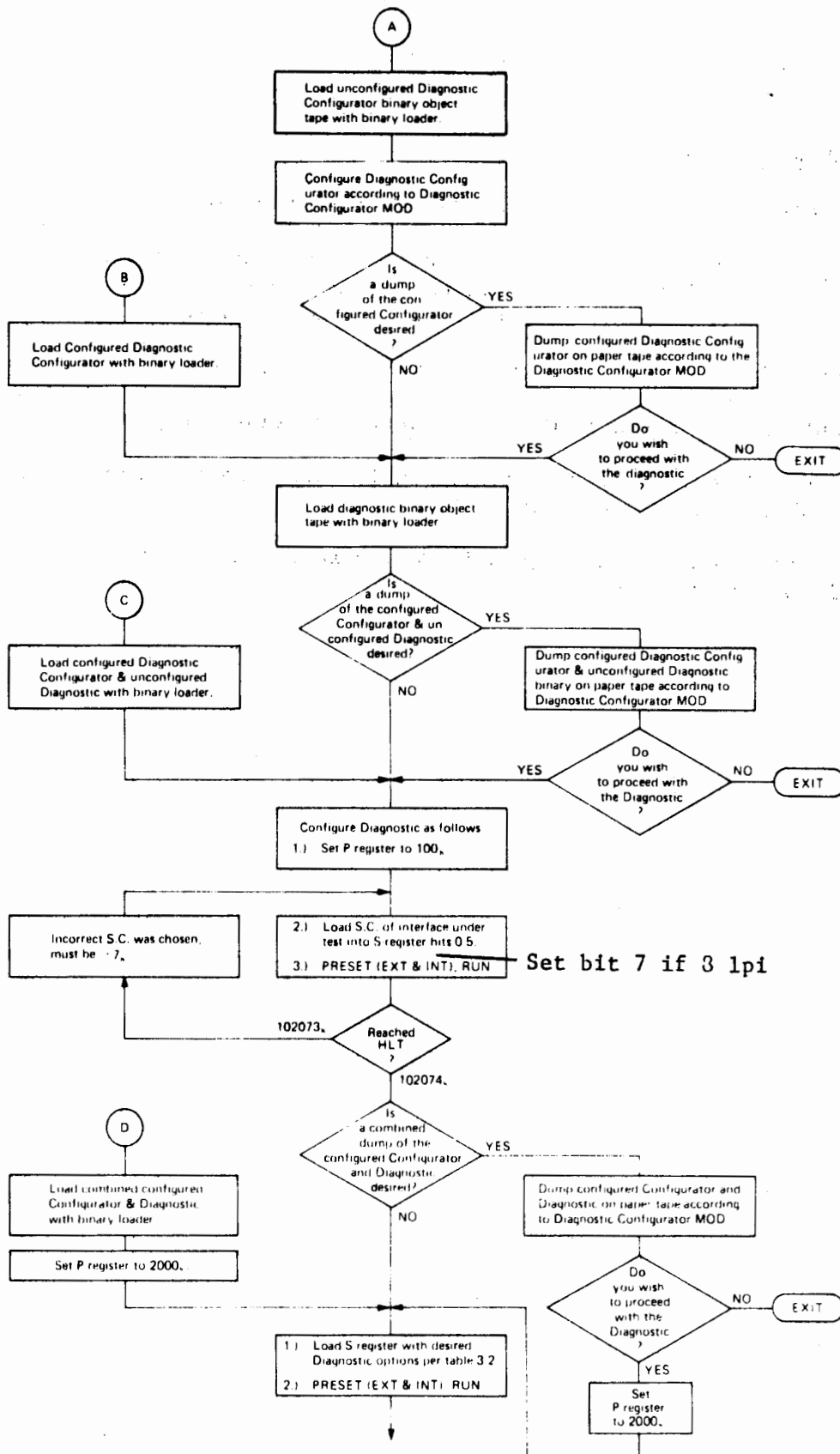

OPERATING PROCEDURE FLOWCHART
Figure 3-1.

3-2. RUNNING THE DIAGNOSTIC

Upon initial start-up of the diagnostic, the introductory message

"2613-2618 LINE PRINTER DIAG

will be displayed on the console device.



At the completion of each pass of the diagnostic, the pass count is output to the console for operator information. If Switch Register bit 12 was not selected the computer will halt with 102077₈ in the Memory Data Register (T-register). At this point, the A-register contains the pass count. To run another pass, the operator need only to press RUN.

If a trap cell halt occurs (106077₈), the user must determine the cause of the interrupt or transfer of control to the location in the M-register. The program may need to be reloaded to continue.

When a halt occurs and/or a message is printed on the console device the operator must refer to Table 4-5 for the meaning of the halt.

3-3. TEST SELECTION BY OPERATOR

The control portion of the program allows the operator the option to select a test or sequence of tests to be run. The operator sets Switch Register bit 9 to indicate that he wants to make a selection and presses RUN. The computer will come to a halt 102075₈ to indicate it is ready for the selection. If the program is running, the test in progress will be completed and then the program will halt. Now the operator loads the A-register with the tests desired. Bit 0 of the A-register represents Test 00, bit 1 represents Test 01, and so on up to bit 8, which represents Test 10. The operator must then clear Switch Register bit 9 and press RUN. The operator-selected test(s) will then be run. However, if the operator clears all bits, then all tests defined in Table 3-1 will be executed with the exception of Test 10. To run Test 10 the operator must select Bit 8 in the A-Register.

Table 3-1. Test Selection Summary

A-REGISTER BIT	IF SET WILL EXECUTE
0	Test 00 BI-0 Test
1	Test 01 Manual Control Test
2	Test 02 Ripple Print Test
3	Test 03 Triangular Print Test
4	Test 04 Vertical Format Control Test
5	Test 05 Character Set Test
6	Test 06 Overprint and Buffer Overlay Test
7	Test 07 DMA Test
8	Test 10 Operator Design
9-15	Reserved
B-Register	Reserved

3-5. RESTARTING

The program may be restarted by setting the P-register to 2000₈, load S-register with desired diagnostic option per Table 3-2, press PRESET (EXT & INT), RUN. The introductory message will always be repeated.

Tabel 3-2. Switch Register Options

BIT	MEANING IF SET
0	Reserved
1	Reserved
2	Reserved
3	Reserved
4	Reserved
5	Reserved
6	Reserved
7	Reserved
8	Suppress tests requiring operator intervention.
9	Abort current diagnostic execution and halt (102075); user may specify a new group of tests in the A-register (see Table 3-1) clear bit 9 and then press RUN.
10	Suppress non-error messages.
11	Suppress error messages.
12	Repeat all selected tests after diagnostic run is complete without halting. Message "PASS XXXXXX" will be output before looping unless bit 10 is set or teletype is not present. Also, those tests requiring operator intervention will be suppressed.
13	Repeat last test executed (loop on test).
14	Suppress error halts.
15	Halt (102076) at the end of each test; the A-register will contain the test number in octal.

Section IV
DIAGNOSTIC PERFORMANCE

4-1. TEST DESCRIPTION

Tables 4-6 and 4-7 illustrate the command format and the interface status word. Refer to Table 4-5 for additional details on the content of each test.

4-2. BASIC I/O TEST 0 E000-E026

Subtest 1 - Checks the ability to clear, set, and test the interrupt system. The following instruction combinations are tested:

CLF 0 - SFC 0
CLF 0 - SFS 0
STF 0 - SFC 0
STF 0 - SFS 0

Errors in the above sequences produce error messages E000-E003 as shown in Table 4-5.

Subtest 2 - Checks the ability to clear, set, and test the interface flag. The following instruction combinations are tested:

CLF CH - SFC CH
CLF CH - SFS CH
STF CH - SFC CH
STF CH - SFS CH

Errors in the above sequences produce error messages E005-E010 as shown in Table 4-5.

Subtest 3 - Checks that the test select code does not cause an interrupt with the Flag and Control set on the interface and the interrupt system off. The sequence of instructions is shown below:

STF CH
STC CH
STF 0
CLF 0

The CLF 0 instruction should inhibit an interrupt from occurring. Error message E004 occurs if CLF 0 fails.

Subtest 4 - Checks that the Flag of the interface under test is not set when all other select code Flags are set. Error message E011 occurs if a Flag is set incorrectly.

Subtest 5 - Checks the ability of the interface to interrupt. With the Flag and Control set and the interrupt system on, there should be an interrupt on channel CH; if not, error message E014 occurs. Checks that the interrupt occurred where expected. The interrupt should not occur before a string of priority-affecting instructions are executed. The following instructions are used to check the hold off operation:

```
STC 1
STF 1
CLC 1
CLF 1
JMP *+1,I
DEF *+1
JSB *+1,I
DEF *+1
NOP
```

Error messages E012 and E015 will occur if the hold off fails. Checks that another interrupt doesn't occur when the interrupt system is turned back on. Error message E013 will occur if an interrupt does occur. Checks that no instruction was missed during the interrupt (E026 INT EXECUTION ERROR).

Subtest 6 - Checks that with the interrupt system on and the CH Control and Flag set, there is no interrupt following a CLC CH instruction. The following sequence of instructions are used:

```
STC CH
STF CH
STF 0
CLC CH
```

If the CLC CH fails to inhibit an interrupt, error message E016 will occur.

Subtest 7 - Checks that the CLC 0 instruction inhibits interrupts when the CH Control and Flag are set. The following sequence of instructions is used:

```
CLF CH
STC CH
STF CH
STF 0
CLC 0
```

If the CLC 0 fails to inhibit an interrupt, error message E017 will occur.

Subtest 8 - This subtest is bypassed if the operator chooses to suppress tests requiring operator intervention. If not suppressed, message H024 is displayed on the system console. When the operator presses run the following are checked:

1. Sets interface Flag (EXTERNAL).
2. Clears Control (EXTERNAL).
3. Turns off the interrupt system (INTERNAL).
4. Clears the I/O data lines (EXTERNAL).

Error messages E017, E019, E020, and E021 may result from this test. At the conclusion of this test message H025 is displayed on the system console.

4-3. MANUAL CONTROL TEST

Test 01

This test allows the operator to test the manual controls of the line printer and to insure that the proper status is reported. If switch register option bits 12 or 8 (see Table 3-2) are set the test will be skipped.

Note: If a teleprinter is not available the operator may run the following subtests by using the halt codes displayed in the Memory Data Register (T-register).

Subtest 1 - The message shown below is output to the teleprinter:

"H040 PWR OFF LP, PRESS RUN"

The operator turns off the line printer power and presses RUN. The program reads the printer status which should be 140001₈. If it is incorrect, error message E050 is printed. To continue, press RUN.

Subtest 2 - The message shown below is output to the teleprinter:

"H041 PWR ON, ON LINE LP, PRESS RUN"

The operator turns on the line printer power and presses RUN. The program reads the printer status which should be 100001₈. If it is incorrect, error message E051 is printed. To continue, press RUN.

Subtest 3 - The message shown below is output to the teleprinter:

"H042 LP TO OFF LINE, PRESS RUN"

The operator sets the line printer to OFF LINE. The ON LINE indicator should extinguish. To continue, press RUN. The program reads the printer status which should be 000000₈. If it is incorrect, error message E052 is printed. To continue, press RUN.

Subtest 4 - The message shown below is output to the teleprinter:

"H043 LP TO ON LINE, PRESS RUN"

The operator sets the line printer to ON LINE. The ON LINE indicator should light. To continue, press RUN. The program reads the printer status which should be 100001₈. If it is incorrect, error message E053 is printed. To continue, press RUN.

Subtest 5 - The message shown below is output to the teleprinter:

"H044 OPEN DRUM GATE, PRESS RUN"

The operator moves drum gate latch to the left and pulls forward. The drum gate indicator should light. To continue, press RUN. The program reads the printer status which should be 040000₈. If it is incorrect, error message E054 is printed. To continue, press RUN.

Subtest 6 - The message shown below is output to the teleprinter:

"H046 REMOVE PAPER, CLOSE DRUM GATE, PRESS RUN"

The operator removes the paper from the printer. The paper fault indicator should light. To continue, press RUN. The program reads the printer status which should be 040000₈. If incorrect, error message E055 is printed. To continue, press RUN.

Subtest 7 - The message shown below is output to the teleprinter:

"H047 RESTORE PAPER, ON LINE LP, PRESS RUN"

The operator puts the paper back into the printer (the paper fault indicator should extinguish) and set the line printer to ON LINE. To continue, press RUN. The next test selected is entered.

4-4. RIPPLE PRINT TEST

Test 02

The ripple print test is a general printing test. It prints a ripple pattern which is a set of lines containing all printable characters rotated one print position on each succeeding line. A total of 96 lines are printed. A form feed is performed at the end of the printing to start the next test.

4-5. TRIANGULAR PRINT TEST

Test 03

The triangular print test prints a triangular pattern consisting of 136 lines of the character M. If the printer under test is a 2618 or 2617 the first five lines are 132 characters long. If the printer under test is a 2613 the first line contains 136 characters. Every successive line contains one less character. A form feed is performed at the end of the printing to start the next test.

4-6. VERTICAL FORMAT CONTROL TEST

Test 04

This test verifies the operation of the various format control functions. The functions are divided into two groups. The first group consists of the twelve functions provided by the twelve channels on the vertical format control tape (VFU). The following functions are exercised:

Table 4-1

<u>FUNCTION</u>	<u>NO. OF TIMES PERFORMED</u>	<u>OCTAL CODE</u>	<u>OPERATION</u>	<u>VFU CHANNEL</u>
TOF	1	100100	Top of form	1
BOF	1	100101	Bottom of form	2
TOF	1	100100	Top of form	1
BOF	1	100101	Bottom of form	2
SS	120(160)*	100102	Single space	3
DS	60(80)*	100103	Double space	4
TS	40(54)*	100104	Triple space	5
QP	8	100106	Next quarter page	7
HP	4	100105	Next half page	6
BOF	1	100110	Bottom of form	2
SP(EP)*	12(16)*	100107	Next sixth(eighth)*page	8
** CH 10	1	100111	One space before BOF	10
** CH 9	1	100110	Bottom of form	9
** CH 11	1	100112	One space before TOF	11
** CH 12	1	100113	Top of form	12

* () = 8 lines per inch

** These functions exercised after line control functions below. The second group consists of the "Line Control" functions:

Table 4-2

<u>FUNCTION (SLEW)</u>	<u>OCTAL CODE</u>	<u>LINES SLEWED</u>
S0	100000	0
S1	100001	1
S2	100002	2
S3	100003	3
S4	100004	4
S5	100005	5
S6	100006	6
S7	100007	7
S8	100010	8
S9	100011	9
S10	100012	10
S11	100013	11
S12	100014	12
S13	100015	13
S14	100016	14
S15	100017	15

Channel 9 and 12 have read back status (IOBI-13 and IOBI-12 respectively). After each of the VFU codes for channels 9, 10, 11 and 12 are executed the status is checked. When an error is detected the appropriate error message (E060-E063) is printed, indicating the status of IOBI-13 and IOBI-12. A VFU test tape is provided with the diagnostic and must be installed on the line printer before running the test.

This test checks all holes on the VFU tape channels, producing 17 pages of printing.

A form feed is performed at the end of the test to start the next test.

4-7. CHARACTER SET TEST

Test 05

This test verifies that all codes yield the correct characters which in turn are printed properly. The test prints one line of each character starting with octal code 000₈ and ending with 177₈.

The first 33 lines are printed with space codes. The character codes from 0 to 40₈ are interpreted as a space code.

A form feed is performed at the end of the printing to start the next test. See Table 4-3 for character set codes.

4-8. OVERPRINT & BUFFER OVERLAY TEST

Test 06

The overprint section of this test checks the ability of the printer to print without spacing. The program outputs one line of the character "H" and then a print command without a line slew (100000₈). The program then outputs another line of the character "I" followed by a print command with one line slewed (100001₈). This will produce one line of 132/136 characters consisting of an "H" overprinted with an "I" (H).

The Buffer Overlay Test checks that all characters are truncated after the 132/136 character has been sent. The test sends 136 characters of the letter "A" without executing a print command. Then 136 characters of the letter "B" are sent. A print command is then executed causing one line of a 132/136 "A's" to be printed.



Table 4-3
Character Code Chart

b ⁷	b ⁶	b ⁵	b ⁴	b ³	b ²	b ¹	0 0 0	0 1 0	0 1 1	1 0 0	1 0 1	1 1 0	1 1 1
b ⁷	b ⁶	b ⁵	b ⁴	b ³	b ²	b ¹							
0	0	0	0	0	0	0		Space	0	@	P	/	P
0	0	0	0	1	0	0		!	1	A	Q	a	q
0	0	0	1	0	0	0		"	2	B	R	b	r
0	0	0	1	1	0	0		#	3	C	S	c	s
0	0	1	0	0	0	0		\$	4	D	T	d	t
0	0	1	0	1	0	0		%	5	E	U	e	u
0	0	1	1	0	0	0		&	6	F	V	f	v
0	0	1	1	1	0	0		'	7	G	W	g	w
1	0	0	0	0	0	0		(8	H	X	h	x
1	0	0	0	1	0	0)	9	I	Y	i	y
1	0	0	1	0	0	0		*	:	J	Z	j	z
1	0	0	1	1	0	0		+	;	K	[k	{
1	0	1	0	0	0	0		,	<	L	\	l	
1	0	1	0	1	0	0		-	=	M]	m	~
1	0	1	1	0	0	0		.	>	N	^	n	?
1	0	1	1	1	0	0		/	?	O	_	o	
1	1	0	0	0	0	0							
1	1	0	0	0	1	0							
1	1	0	0	1	0	0							
1	1	0	0	1	1	0							
1	1	0	1	0	0	0							
1	1	0	1	0	1	0							
1	1	0	1	1	0	0							
1	1	0	1	1	1	0							
1	1	1	0	0	0	0							
1	1	1	0	0	1	0							
1	1	1	0	1	0	0							
1	1	1	0	1	1	0							
1	1	1	1	0	0	0							
1	1	1	1	0	1	0							
1	1	1	1	1	0	0							
1	1	1	1	1	1	0							

4-8. DMA Test

Test 07

The DMA test verifies that the Line Printer will run under DMA control. A buffer of 137 characters is output to the printer under DMA. The first 136 words of the buffer is used to store each line of a ripple print pattern test. The 137th word in the buffer contains the print command. After each print command is executed a new line is stored into the buffer. Each line is rotated one print position to the left on each succeeding line. A total of 96 lines are printed. A form feed is performed at the end of the DMA test to start the next test.

This test will be executed only if the DMA option has been specified during the set-up procedure of the CONFIGURATOR. It is assumed that the DMA hardware is working correctly and only the service request logic of the line printer interface and corresponding timing relation are to be tested.

4-10. Operator Design

Test 10

If a console device is specified during configuration set-up, it allows the user to design and execute his own program to test line printer functions. Upon entry to this routine, the message "OPDSN SECTION" is printed on the teleprinter followed by a "@". The user then selects OPDSN instructions, enters them on the teleprinter and starts execution as described in Appendix. If switch register options bits 12 or 8 (Table 3-2) are set the test will be skipped.

Table 4-4. Halt Code Summary

HALT	MEANING
TESTS 0 ₈ to 10 ₈ 102000-102067	Error (E) & information (H) messages 00-063 ₈ .
CONTROL 102073	Select code input error.
102074	Select code input complete.
102075	User selection request.
102076	End of test (A = test number).
102077	End of diagnostic run.
106077	Trap cell halts in location 2-77 ₈ .

NOTE: See Table 4-5 for complete explanation of individual halts.

Table 4-5. Error Information Messages and Halt Codes

HALT CODE	SECTION	MESSAGE	COMMENTS
102073	Configuration	None	I/O select code entered at configuration is invalid. Must be greater than 7_8 . Reenter a valid select code and press RUN.
102074	Configuration	None	Select code entered during configuration is valid. Enter program option bits in Switch Register and press RUN.
102075	Test Control	None	Test selection request resulting from Switch Register bit 9 being set. Enter in A-register the desired group of tests to be executed, clear bit 9 in Switch Register and press RUN. (See Table 3-1).
102076	Test Control	None	End-of-test halt resulting from Switch Register bit 15 being set (A-register has the test number). To continue, press RUN.
102077	Test Control	PASS XXXXXX	Diagnostic run complete. Register options may be changed (A-register has the pass count). To continue press RUN.
106077	Test Control	None	Halt stored in location 2-77 ₈ to trap interrupts which may occur unexpectedly because of hardware malfunctions. M-register contains the I/O slot which interrupted. Diagnostic may be partially destroyed if halt occurs. The program may have to be reloaded; the problem should be corrected before proceeding.
None	Test Control	2613-2618 LINE PRINTER DIAG	Introductory message.

Table 4-5. Error Information Messages and Halt Codes (continued)

HALT CODE	SECTION	MESSAGE	COMMENTS
None	Test Control	TEST XX	Information message before error message (XX = test number). Message occurs only once within a test but is suppressed for any subsequent messages within the same test.
102000	Test 0	E000 CLF 0-SFC 0 ERROR	CLF/SFC 0 combination failed. CLF did not clear Flag or SFC caused no skip with Flag clear.
102001	Test 0	E001 CLF 0-SFS 0 ERROR	CLF/SFS 0 combination failed. CLF did not clear Flag or SFS caused skip with Flag clear.
102002	Test 0	E002 STF 0-SFC 0 ERROR	STF/SFC 0 combination failed. STF did not set Flag or SFC caused skip with Flag set.
102003	Test 0	E003 STF 0-SFS 0 ERROR	STF/SFS 0 combination failed. STF did not set Flag or SFS caused no skip with Flag set.
102004	Test 0	E004 CLF 0 DID NOT INHIBIT INT	With card Flag and Control set, CLF 0 did not turn off interrupt system.
102005	Test 0	E005 CLF CH- SFC CH ERROR	CLF/SFC CH combination failed. CLF did not clear Flag or SFC caused no skip with Flag clear.
102006	Test 0	E006 CLF CH-SFS CH ERROR	CLF/SFS CH combination failed. CLF did not clear Flag or SFS caused skip with Flag clear.
102007	Test 0	E007 STF CH- SFC CH ERROR	STF/SFC CH combination failed. STF did not set Flag or SFC caused skip with Flag set.
102010	Test 0	E010 STF CH- SFS CH ERROR	STF/SFS CH combination failed. STF did not set Flag or SFS caused no skip with Flag set.
102011	Test 0	E011 STF XX SET CARD FLAG	Select code screen test failed. A-register contains XX ₈ where XX = select code that caused that card Flag to set.

Table 4-5. Error Information Messages and Halt Codes (continued)

HALT CODE	SECTION	MESSAGE	COMMENTS
102012	Test 0	E012 INT DURING HOLD OFF INSTR	Interrupt occurred during an I/O instruction or a JMP/JSB indirect instruction.
102013	Test 0	E013 SECOND INT OCCURRED	Card interrupted a second time after initial interrupt was processed.
102014	Test 0	E014 NO INT	No interrupt occurred with card Flag and Control set and the interrupt system on.
102015	Test 0	E015 INT RTN ADDR ERROR	Interrupt did not occur at the correct location in memory.
102016	Test 0	E016 CLC CH ERROR	CLC CH did not clear card Control with the interrupt system on.
102017	Test 0	E017 CLC 0 ERROR	CLC 0 did not clear Control with the interrupt system on.
102020	Test 0	E020 PRESET (EXT) DID NOT SET FLAG	PRESET (EXT) did not set the card Flag.
102021	Test 0	E021 PRESET (INT) DID NOT DISABLE INTS	PRESET (INT) did not disable the interrupt system.
102022	Test 0	E022 PRESET (EXT) DID NOT CLEAR CONTROL	PRESET (EXT) did not clear Control.
102023	Test 0	E023 PRESET (EXT) DID NOT CLEAR I-O LINES	PRESET (EXT) did not clear I/O data lines.
102024	Test 0	H024 PRESS PRESET (EXT & INT), RUN	Press PRESET (External, Internal) and RUN.

Table 4-5. Error Information Messages and Halt Codes (continued)

HALT CODE	SECTION	MESSAGE	COMMENTS
None	Test 0	H025 BI-O COMP	Basic I/O Tests completed.
102026	Test 0	E026 INT EXECUTION ERROR	Interrupt was not processed correctly.
102030	Test 1-6, 8	E030 FLAG FAILED TO SET	With the interrupt system off, device flag failed to set.
102031	Test 1-6, 8	E031 LP FAILED TO INT	With interrupt system on, line printer failed to interrupt.
102032	Test 1-8	E032 LP NOT RDY	Line printer status indicates that printer is not ready.
102033	Test 7	H033 DMA NOT CONFIG	DMA option bit not set during configuration of the CONFIGURATOR.
102034	Test 7	E034 DMA TIME OUT	DMA or card failed to set flag after a block transfer.
102035	Test 7	E035 I-O FLAG NOT SET AFTER DMA COMP	DMA completed a block transfer but the interface card did not set its flag to indicate it was finished.
102036	Test 1-6, 8	E036 DEMAND BUSY	Line printer status indicates that demand bit is busy.
102040	Test 1	H040 PWR OFF LP, PRESS RUN	Operator turns off line printer power and presses RUN.
102041	Test 1	H041 PWR ON, ON LINE LP, PRESS RUN	Operator turns line printer power on, puts LP to on line and presses RUN.
102042	Test 1	H042 LP TO OFF LINE, PRESS RUN	Operator sets LP to off line (indicator light off) and presses RUN.
102043	Test 1	H043 LP TO ON LINE, PRESS RUN	Operator sets LP to on line (indicator light on) and presses RUN.
102044	Test 1	H044 OPEN DRUM GATE, PRESS RUN	Operator opens DRUM GATE and (indicator light on) presses RUN.

Table 4-5. Error Information Messages and Halt Codes (continued)

HALT CODE	SECTION	MESSAGE	COMMENTS
102046	Test 1	H046 REMOVE PAPER, CLOSE DRUM GATE, PRESS RUN	Operator removes paper from line printer (indicator light on) and presses RUN.
102047	Test 1	H047 RESTORE PAPER, ON LINE LP, PRESS RUN	Operator restores paper in line printer (indicator light off), puts line printer on line and presses RUN.
102050	Test 1	E050 STATUS IS XXXXXX SHOULD BE 140001	Printer status incorrect as a result of H040 message.
102051	Test 1	E051 STATUS IS XXXXXX SHOULD BE 100001	Printer status incorrect as a result of H041 message.
102052	Test 1	E052 STATUS IS XXXXXX SHOULD BE 000000	Printer status incorrect as a result of H042.
102053	Test 1	E053 STATUS IS XXXXXX SHOULD BE 100001	Printer status incorrect as a result of H043 message.
102054	Test 1	E054 STATUS IS XXXXXX SHOULD BE 040000	Printer status incorrect as a result of H044 message.
102055	Test 1	E055 STATUS IS XXXXXX SHOULD BE 040000	Printer status incorrect as a result of H046 message.
102060	Test 4	E060 STATUS IS XXXXXX SHOULD BE 100001	VFU channel 10 status is incorrect.
102061	Test 4	E061 STATUS IS XXXXXX SHOULD BE 120001	VFU channel 9 status is incorrect.
102062	Test 4	E062 STATUS IS XXXXXX SHOULD BE 100001	VFU channel 11 status is incorrect
102063	Test 4	E063 STATUS IS XXXXXX SHOULD BE 110001	VFU channel 12 status is incorrect

Table 4-5. Error Information Messages and Halt Codes (continued)

HALT CODE	SECTION	MESSAGE	COMMENTS
None	OP Design	OPDSN SECTION @	Introductory message for Operator Design.
None	OP Design	ILLEGAL INPUT	Statement entered after @ symbol was illegal.
None	OP Design	QUE FULL STATEMENT NOT LOADED	Buffer area for program statements is full. The last statement was not entered.
None	OP Design	ERROR X IN LINE N	Statement N contains error X where X = 1 - line number not found 2 - more than 15 GS statements have stacked up without being cleared by RT statement. 3 - An RT statement occurred without any GS statement to return to.
None	OP Design	XY STATUS IS XXXXXX	Line YY statement called for a status reported defined by XXXXXX.

Table 4-6
 Line Printer Status Word
 (IOBI)

15	14	13	12	11	10	9	8	7	6	5	4	3	2	1	0
----	----	----	----	----	----	---	---	---	---	---	---	---	---	---	---

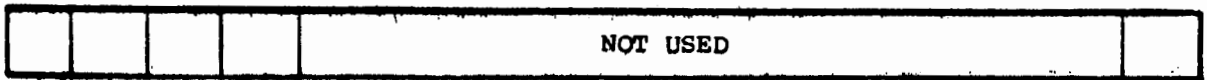

NOT USED

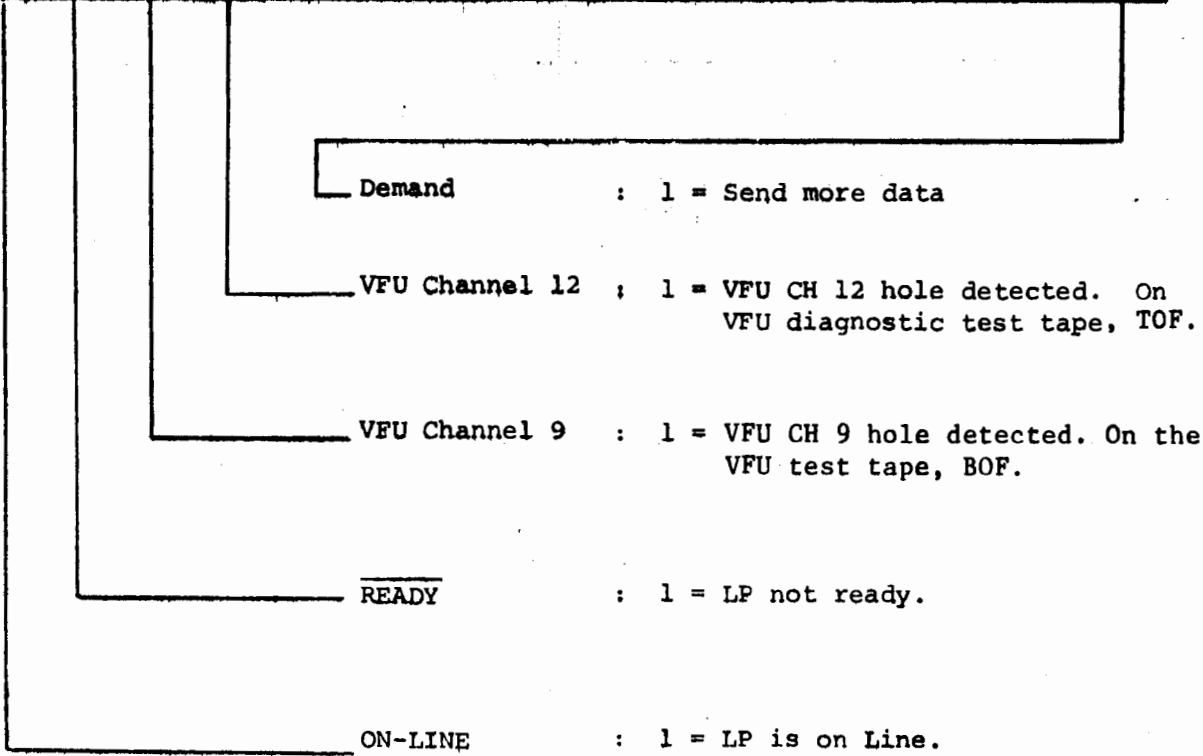

Table 4-7
Line Printer Command Word
(IOBO)

15	14	13	12	11	10	9	8	7	6	5	4	3	2	1	0
----	----	----	----	----	----	---	---	---	---	---	---	---	---	---	---

PI	NOT USED	b ₇	b ₆	b ₅	b ₄	b ₃	b ₂	b ₁
----	----------	----------------	----------------	----------------	----------------	----------------	----------------	----------------

b₁-b₇ refer to ASCII characters (see Table 4-3).

Paper instruction: if bit 15 = 0 then the seven LSB (0-6) will be interpreted as data in ASCII code to be printed (see Table 4-3) if bit 15 = 1, then the seven LSB are regarded as a paper slew or VFU code (see Tables 4-1 and 4-2).

Data bits (if 15 = 0) in ASCII or

Slew/VFU code (if bit 15 = 1): if bit 6 = 0: slew command
see Table 4-2

if bit 6 = 1: VFU command
see Table 4-1

APPENDIX A
OPERATOR DESIGN

The Operator Design (Op Design) section, test 10, provides the means for the operator to produce and execute his own line printer test routine. This section accepts a list of instructions from the operator at the teleprinter. The instructions are executed upon command.

ENTERING OP DESIGN INSTRUCTIONS

When the Op Design section is selected, the message

OPDSN SECTION
@

is printed, where "@" is the prompt for the operator to key in his instruction from those given in Table A-1. Terminate each entry with a CARRIAGE RETURN and LINE FEED.

Table A-1. Op Design Instructions

Instruction	EXECUTION CONTROL	
	Explanation	
LI, <i>nn,mm</i>	List Program. List program from line number <i>nn</i> to line number <i>mm</i> ; if <i>mm</i> is omitted, list to end of program; if <i>nn,mm</i> is omitted, list the entire program.	
DL, <i>nn</i>	Delete Line. Delete program line number <i>nn</i> ; if <i>nn</i> = AL, delete entire program.	
GO, <i>nn</i>	Start Program. Start program execution at line <i>nn</i> ; if <i>nn</i> is not specified, start program execution at first program statement.	
DB, <i>i,t</i>	Define Buffer. Establish the test program buffer with <i>i</i> items of data type, <i>t</i> : <i>t</i> = A specifies ASCII data, where <i>i</i> indicates the number of characters. <i>t</i> = I specifies decimal integer data between -32767 and +32767, where <i>i</i> indicates the number of integers. <i>t</i> = K specifies octal integer data up to 177777 ₈ , where <i>i</i> indicates the number of integers. Enter the previously specified number of ASCII characters on one or several lines. Enter each integer one per line followed by CR/LF.	

Table A-1. Op Design Instructions (continued)

EXECUTION CONTROL (continued)	
Instruction	Explanation
BY	Exit Op Design Program. Operator Design Program is terminated and control returns to Control Program (a HALT with MDR = 102077 occurs).
TEST PROGRAM INSTRUCTIONS	
Instruction	Explanation
<i>nn</i> WA	Wait. Halt execution of program and print out the message " <i>nn</i> WAIT"; to continue program operator keys in "CO"; to stop program and elicit prompt character, "@," operator keys in "ST."
<i>nn</i> GT, <i>mm</i>	Go to. Branch to instruction with line number <i>mm</i> .
<i>nn</i> GS, <i>mm</i> , <i>i</i>	Go Sub. Branch to subroutine which begins on line <i>mm</i> ; if <i>i</i> is specified, repeat subroutine <i>i</i> times before returning to line <i>nn</i> + 1; a subroutine consists of one or more instructions the last of which is an "RT" (Return).
<i>nn</i> RT	Return. Exit from subroutine and continue execution of program from line after calling "GS" instruction; this instruction must be preceded in execution by a calling "GS" instruction.
<i>nn</i> MS, <i>aa</i> , <i>i</i>	Message. At the teleprinter print the message " <i>aa i</i> ", where <i>aa</i> is any two characters and <i>i</i> is a decimal integer.
<i>nn</i> TD, <i>i</i>	Time Delay. Wait <i>i</i> milliseconds before executing the next instruction, where <i>i</i> is between 0 and 32,767 milliseconds.
<i>nn</i> SR	Status Report. Fetch the status word from the interface and and print it on the teleprinter; message format is: <i>nn</i> STATUS IS <i>xx000x</i> where <i>nn</i> is the line number of executing status instruction and <i>xx000x</i> is the status word. (Note that only bits 15,14, 13,12, and 0 hold significant status).
<i>nn</i> SC, <i>xx000x</i> , <i>mm</i>	Status Check. Fetch status word from interface and compare it to <i>xx000x</i> . If the values compare, continue to next instruction; if fetched value \neq <i>xx000x</i> , go to instruction at line <i>mm</i> .
<i>nn</i> CP, <i>i</i> , <i>j</i>	Cyclic Print. Print on the line printer a ripple print pattern, similar to Figure 1, which cycles one character to left for each line printed; <i>i</i> specifies the number of lines output; default for <i>i</i> and <i>j</i> are 132 and 60 respectively.
<i>nn</i> OC, <i>p</i> , <i>i</i>	Output Characters. Output to line printer <i>i</i> characters specified by parameter <i>p</i> ; <i>p</i> = UB means output <i>i</i> characters from buffer defined by "DB" instruction; <i>i</i> defaults to buffer length. <i>p</i> = \$ <i>c</i> means output the character <i>c</i> <i>i</i> times to line printer; <i>i</i> defaults to one character.

Table A-1. Op Design Instructions (continued)

TEST PROGRAM INSTRUCTIONS (continued)	
Instruction	Explanation
<i>nn PC</i>	Print Command. Print the contents of the line printer buffer (a command of 100102, is sent to LP).
<i>nn FF, p, i</i>	Form Feed. Same as "OC" instruction except that output is followed by a FORM FEED; if <i>p</i> and <i>i</i> are not specified, FORM FEED only is sent to LP.
<i>nn VF, v, i</i>	Vertical Form Control. When <i>v</i> = LC, output a LINE CONTROL command, where <i>i</i> specifies the number of lines; default for <i>i</i> = 0 lines. When <i>v</i> = FC, output a FORM CONTROL command, where <i>i</i> specifies the channel number; default for <i>i</i> = 0 (Top of Form). If neither <i>v</i> or <i>i</i> are specified, the default is FORM CONTROL and Top of Form.

INSTRUCTION FORMAT

There are two instruction formats. One format is for instructions executed immediately after entry, called Execution Control instructions, and another format for instructions executed in groups upon command, called Test Program instructions.

Execution Control

These instructions are executed immediately after they are accepted. Consequently, they need no line number. They have the general format:

II,x,y

where *II* is the instruction code and *x* and *y* are parameters, if any. No SPACES should appear in an Execution Control instruction, except that a SPACE may be substituted for a COMMA as a parameter separator.

Test Program Instructions

These instructions are executed in groups as a sequence of commands which perform test functions on the line printer. Since sequence of execution is primarily important, these instructions require a line number in their format:

nn II,x,y

where *nn* is a two digit decimal line number. Line numbers may be entered in any order. They will be executed in line number sequence. One SPACE must follow the line number. Otherwise, the only SPACE that appears is that which may be substituted for the comma as a parameter separator.

EXECUTING THE OP DESIGN PROGRAM

Execution of test program instructions is initiated with the Execution Control instruction "GO". If the test instructions form a closed loop, the program will continue to cycle until terminated by other means such as setting switch register bit 9, which will halt the OP DESIGN program and return to prompt "@" character. If the test instructions do not form a closed loop, the "@" prompt will be printed at the completion of the test program. Exit Op Design by using the "BY" instruction. This will complete a pass of the diagnostic.

OP DESIGN MESSAGES

Three Op Design instruction messages are reported via the teleprinter to the operator. Table A-2 lists the messages and explains the meaning of each.

Table A-2. Op Design Messages

Message	Explanation
ILLEGAL INPUT	Operation code or format of instruction just input by operator is not valid. <i>Remedy:</i> input valid instruction, followed by CARRIAGE RETURN and LINE FEED.
QUE FULL STATEMENT NOT LOADED	Available memory for OP Design program is full; last statement entered was not loaded.
ERROR <i>m</i> IN LINE <i>nn</i>	An error has been detected during the processing of an Op Design instruction after a "GO" was entered; <i>nn</i> is the line number of the instruction in error; <i>m</i> is an error code with the following significance: <i>m</i> = 1 means that the line number specified in a GT or GS instruction was not found; <i>m</i> = 2 means that a GS instruction does not have a matching RT instruction; <i>m</i> = 3 means an RT instruction was detected before a matching GS instruction was detected.

Test Program Examples

EXAMPLE 1.

```

@02 SC,100001,30(CR/LF)
@08 FF(CR/LF)
@10 OC,$W,132(CR/LF)
@12 PC(CR/LF)
@14 GS,16,30(CR/LF)
@15 GT,02(CR/LF)
@16 OC,$E,75(CR/LF)
@18 PC(CR/LF)
@20 RT(CR/LF)
@30 MS,ER,01(CR/LF)
@GO
    
```

Flow of Example is shown in Figure A-1. Printout is shown in Figure A-2. If status is bad, the teleprinter prints out:

```

*ER 00001
@
    
```

and is ready for operator input.

EXAMPLE 2.

```

@DB,1,A(CR/LF executed by diagnostic)
Z(CR/LF executed by diagnostic)
@10 OC,UB(CR/LF)
@20 PC(CR/LF)
@GO(CR/LF)
@
    
```

The EXAMPLE 2 test program executes once, printing one "Z" on the line printer. Then the Op Design program outputs the "@" prompt signalling completion of the program.

The operator can then add to the program:

```

@05 FF(CR/LF)
@GO(CR/LF)
    
```

This will produce a FORM FEED before each printout on the line printer. Use the "LI" command to list program:

```

@LI(CR/LF)
0005 FF
0010 OC UB
0020 PC
**LIST END**
@
    
```

Note that "LI" function removes commas and fills in leading zeros.

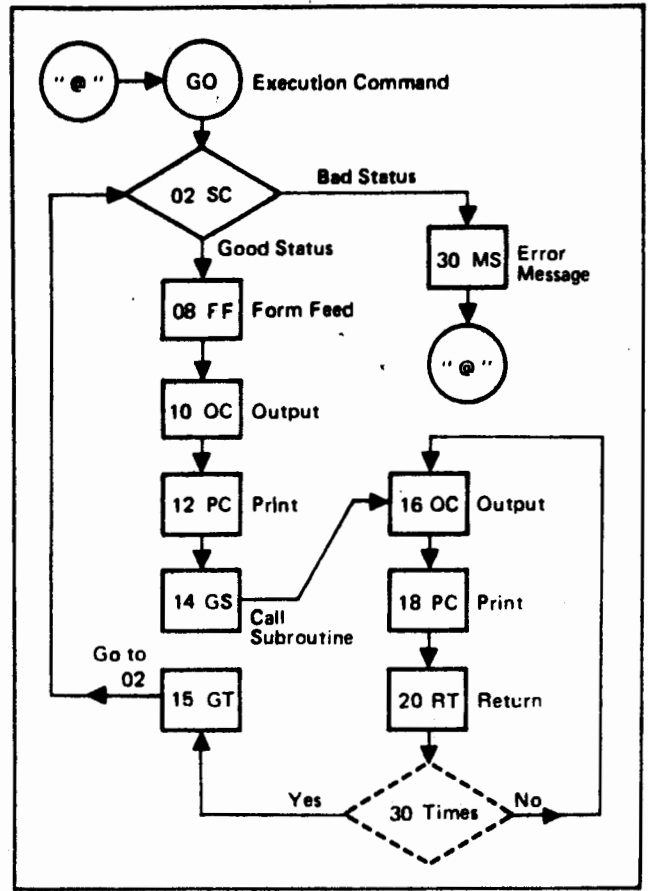

Figure A-1.OP DESIGN EXAMPLE



MANUAL PART NO. 02618-90006
MICROFICHE PART NO.02618-90009

PRINTED IN U.S.A.