

HEWLETT  PACKARD

REFERENCE MANUAL



12960A

CARTRIDGE DISC SUBSYSTEM
(FOR HP 2100-SERIES COMPUTER SYSTEMS)

Options Covered

This manual covers options 010, 015, 020, and 025 in addition to the standard HP 12960A Cartridge Disc Subsystem.

HP Computer Museum
www.hpmuseum.net

For research and education purposes only.

HP 12960A CARTRIDGE DISC SUBSYSTEM

GENERAL DESCRIPTION

The HP 12960A Cartridge Disc Subsystem consists of all the equipment and support publications required to provide high-speed mass storage and retrieval capabilities for the HP 2100-Series Computer Systems equipped with DMA. The basic configuration of this subsystem provides 5 megabyte storage capacity and consists of an HP 7900A Disc Drive, an HP 13210A Disc Drive Interface Kit, and an HP 13215A Disc Power Supply. One option of this basic version adds another disc drive, power supply, and an HP 13212A Multiunit Cable. Since the interface can handle up to four disc drives, no additional interface is necessary with this option. Two additional options to the basic version provide DOS-M and DOS-III software. A fourth option to the basic version provides for 230-volt, 50-hertz operation. Additional details regarding subsystem components are provided in the operating and service manuals supplied with the subsystem.

EQUIPMENT SUPPLIED

The following equipment and documentation are supplied with the standard subsystem and options:

- HP 12960A — HP 7900A Disc Drive; HP 13210A Disc Drive Interface Kit; HP 13215A Disc Power Supply; *HP 7900A Disc Drive Operating and Service Manual*, part no. 07900-90002; *HP 13210A Disc Drive Interface Kit Operating and Service Manual*, part no. 13210-90003; *HP 13215A Disc Power Supply Operating and Service Manual*, part no. 13215-90003.
- HP 12960A-010 — HP 7900A Disc Drive; HP 13215A Disc Power Supply; HP 13212A Multiunit Cable; *HP 7900A Disc Drive Operating and Service Manual*, part no. 07900-90002; *HP 13215A Disc Power Supply Operating and Service Manual*, part no. 13215-90003.
- HP 12960A-020 — HP 7900A Disc Drive; HP 13210A Disc Drive Interface Kit; HP 13215A Disc Power Supply; HP 24379A DOS-M Software and Manuals including *Moving-Head Disc Operating System Manual*, part no. 02116-91779; DOS-M Disc Driver, part no. 24156-60001; *HP 7900A Disc Drive Operating and Service Manual*, part no. 07900-90002; *HP 13210A Disc Drive Interface Kit Operating and Service Manual*, part no. 13210-90003; *HP 13215A Disc Power Supply Operating and Service Manual*, part no. 13215-90003.

EQUIPMENT SUPPLIED (Continued)

- HP 12960A-025 — HP 7900A Disc Drive; HP 13210A Disc Drive Interface Kit; HP 13215A Disc Power Supply; HP 24307A DOS-III Software and Manuals including *DOS-III Disc Operating System Manual*, part no. 02100-90136; DOS-M Disc Drive, part no. 24156-60001; *HP 7900A Disc Drive Operating and Service Manual*, part no. 07900-90002; *HP 13210A Disc Drive Interface Kit Operating and Service Manual*, part no. 13210-90003; *HP 13215A Disc Power Supply Operating and Service Manual*, part no. 13215-90003.

ACCESSORIES

One HP 12869A Disc Cartridge and one HP 13211A-001 Rack Slide Mounting Kit is supplied with each HP 7900A Disc Drive.

OPTIONS

- HP 12960A — Provides complete 5 megabyte subsystem using 115-volt, 60-hertz power.
- HP 12960A-010 — Provides an additional 5 megabyte disc drive to a subsystem that uses 115-volt, 60-hertz power.
- HP 12960A-015 — Provides complete 5 megabyte subsystem using 230-volt, 50-hertz power.
- HP 12960A-020 — Provides DOS-M software for the subsystem.
- HP 12960A-025 — Provides DOS-III software for the subsystem.

SALES & SERVICE OFFICES

AFRICA, ASIA, AUSTRALIA

AMERICAN SAMOA

Calculators Only
Oceanic Systems Inc.
P.O. Box 777
Pago Pago Bayfront Road
Pago Pago 96799
Tel: 633-5513
Cable: OCEANIC-Pago Pago

ANGOLA

Teletra
Empresa Técnica de
Equipamentos
Elétricos, S.A. R.L.
R. Barbosa Rodrigues, 42-PDT.
Caixa Postal, 6487
Luanda
Tel: 35515/6
Cable: TELETRIA Luanda

AUSTRALIA

Hewlett-Packard Australia
Pty. Ltd.
31-41 Joseph Street
Blackburn, Victoria 3130
P.O. Box 38
Dandenong East, Victoria 3109
Tel: 89-6351
Telex: 31-024
Cable: HEWPARD Melbourne
Hewlett-Packard Australia
Pty. Ltd.
31 Bridge Street
Pymble
New South Wales, 2073
Tel: 449-6566
Telex: 21561
Cable: HEWPARD Sydney
Hewlett-Packard Australia
Pty. Ltd.
153 Greenhill Road
Parkside, 5063, S.A.
Tel: 27-2591
Telex: 82536 ADEL
Cable: HEWPARD ADELAIDE
Hewlett-Packard Australia
Pty. Ltd.
141 Stirling Highway
Medlands, W.A. 6009
Tel: 86-5455
Telex: 83859 PERTH
Cable: HEWPARD PERTH
Hewlett-Packard Australia
Pty. Ltd.
121 Wollongong Street
Fyshwick, A.C.T. 2608
Tel: 95-3733
Telex: 62850 Canberra
Cable: HEWPARD CANBERRA
Hewlett-Packard Australia
Pty. Ltd.
5th Floor
Teachers Union Building
495-499 Boundary Street
Spring Hill, 4000 Queensland
Tel: 291-544
Telex: 42133 BRISBANE

GUAM

Medical Pocket Calculators Only
Guam Medical Supply, Inc.
Jay Euse Building, Room 210
P.O. Box 8383
Tamuning 96911
Tel: 646-4513
Cable: EARMED Guam

HONG KONG

Schmidt & Co. (Hong Kong) Ltd.
P.O. Box 297
Connaught Centre
39th Floor
Connaught Road, Central
Hong Kong
Tel: H-255291-5
Telex: 74766 SCHMC HX
Cable: SCHMIDTCD Hong Kong

INDIA

Blue Star Ltd.
Kastur Buildings
Jamsheer Tata Rd.
Bombay 400 020
Tel: 29 50 21
Telex: 2156
Cable: BLUEFROST
Blue Star Ltd.
Saras
4142 Vir Savarkar Marg
Prabhadevi
Bombay 400 025
Tel: 45 78 87
Telex: 4093
Cable: FROSTBLUE
Blue Star Ltd.
Band Box House
Prabhadevi
Bombay 400 025
Tel: 45 73 01
Telex: 3751
Cable: BLUESTAR
Blue Star Ltd.
14/40 Civil Lines
Kanpur 208 001
Tel: 8 88 82
Telex: 292
Cable: BLUESTAR
Blue Star Ltd.
7 Hare Street
P.O. Box 506
Calcutta 700 001
Tel: 23-0131
Telex: 7855
Cable: BLUESTAR
Blue Star Ltd.
34 Mahatma Gandhi Rd.
Lajpatnagar
New Delhi 110 024
Tel: 62 32 76
Telex: 2463
Cable: BLUESTAR
Blue Star Ltd.
11/11A Magarath Road
Bangalore 560 025
Tel: 55668
Telex: 430
Cable: BLUESTAR

Blue Star Ltd.
Meesakshi Mandiran
xxx1678 Mahatma Gandhi Rd.
Cochin 682 016 Kerala
Tel: 32069, 32161, 32282
Telex: 046-514
Cable: BLUESTAR
Blue Star Ltd.
1-1-1171
Sarjani Devi Road
Secunderabad 500 003
Tel: 70126, 70127
Cable: BLUEFROST
Telex: 459

Blue Star Ltd.
23/24 Second Line Beach
Madras 600 001
Tel: 23954
Telex: 379
Cable: BLUESTAR
Blue Star Ltd.
Nathraj Mansions
2nd Floor Bistapur
Jammedpur 831 001
Tel: 7383
Cable: BLUESTAR
Telex: 240

INDONESIA
BERCA Indonesia P.T.
P.O. Box 496
1st Floor J.L. Cikini Raya 61
Jakarta
Tel: 56038, 40369, 49886
Telex: 42885
Cable: BERCACON
BERCA Indonesia P.T.
63 J.L. Raya Gubeng
Surabaya
Tel: 44309

ISRAEL
Electronics & Engineering Div.
of Motorola Israel Ltd.
16, Kremenetski Street
P.O. Box 25016
Tel-Aviv
Tel: 03-389 73
Telex: 33569
Cable: BASTEL Tel-Aviv

JAPAN
Yokogawa-Hewlett-Packard Ltd.
Ohashi Building
1-59-1 Yoyogi
Shibuya-ku, Tokyo
Tel: 03-370-2281/92
Telex: 232-2024YHP
Cable: YHPMARKET TOK 23-724

Yokogawa-Hewlett-Packard Ltd.
Nissei Ibaraki Building
2-8 Kasuga 2-chrome, Ibaraki-shi
Osaka 567
Tel: (0726) 23-1641
Telex: 5332-385 YHP DSAKA
Yokogawa-Hewlett-Packard Ltd.
Nakamo Building
24 Kami Sasajima-cho
Nakamura-ku, Nagoya 450
Tel: (052) 571-5171

Yokogawa-Hewlett-Packard Ltd.
Tanigawa Building
2-24-1 Tsuriya-cho
Kanagawa-ku
Yokohama, 221
Tel: 045-312-1252
Telex: 382-3204 YHP YOK

Yokogawa-Hewlett-Packard Ltd.
Wito Mitsui Building
105, 1-chrome, San-no-maru
Mito, Ibaragi 310
Tel: 0292-25-7470
Yokogawa-Hewlett-Packard Ltd.
Inoue Building
1348-3, Asahi-cho, 1-chrome
Atsugi, Kanagawa 243
Tel: 0462-24-0452

KENYA
Technical Engineering Services
(E.A.) Ltd.
P.O. Box 18311
Nairobi
Tel: 55726/556762
Cable: PROTON
Medical Only
International Aeradio(E.A.) Ltd.
P.O. Box 19012
Nairobi Airport
Nairobi
Tel: 336055/56
Telex: 22201/22301
Cable: INTAERID Nairobi

KOREA
American Trading Company
Korea
C.P.O. Box 1103
Dae Kyung Bldg, 8th Floor
107 Sejong-Ro,
Chongro-Ku, Seoul
Tel: (4 lines) 73-8924-7
Telex: K-26338
Cable: AMTRACO Seoul

MALAYSIA
Teknik Mutu Sdn. Bhd.
2 Lorong 13/6A
Section 13
Petaling Jaya, Selangor
Tel: Kuala Lumpur-54994 or 54916
P.O. Box 37605
Proton Engineering
P.O. Box 1917
Lot 259, Satok Road
Kuching, Sarawak
Tel: 20262
Cable: PROTEL ENG

MOZAMBIQUE
A.M. Goncalves, Lda.
162, 1st Apt. 14 Av. D. Luis
Caixa Postal 107
Lourenco Marques
Tel: 27091, 27114
Telex: 6-203 Negon Mo
Cable: NEGON

NEW ZEALAND
Hewlett-Packard (N.Z.) Ltd.
4-12 Cruickshank Street
Kilmore, Wellington 3
Mailing Address: Hewlett-Packard
(N.Z.) Ltd.
P.O. Box 9443
Courtney Place
Wellington
Tel: 877-199
Telex: NZ 3839
Cable: HEWPACK Wellington
Hewlett-Packard (N.Z.) Ltd.
Pakuranga Professional Centre
267 Pakuranga Highway
Box 51092
Pakuranga
Tel: 569-651
Telex: NZ 3839
Cable: HEWPACK Auckland
Analytical/Medical Only
Medical Supplies N.Z. Ltd.
Scientific Division
79 Carlton Gore Rd., Newmarket
P.O. Box 1234
Auckland
Tel: 75-289
Telex: 2958 MEDISUP
Cable: DENTAL Auckland
Analytical/Medical Only
Medical Supplies N.Z. Ltd.
P.O. Box 1994
147-161 Tory St.
Wellington
Tel: 850-799
Telex: 3858
Cable: DENTAL, Wellington
Analytical/Medical Only
Medical Supplies N.Z. Ltd.
P.O. Box 309
238 Stammers Road
Christchurch
Tel: 892-019
Cable: DENTAL, Christchurch
Analytical/Medical Only
Medical Supplies N.Z. Ltd.
303 Great King Street
P.O. Box 233
Dunedin
Tel: 88-817
Cable: DENTAL, Dunedin

NIGERIA
The Electronics
Instrumentations Ltd.
N68/770 Oyo Road
Oluseun House
P.M.B. 5402
Ibadan
Tel: 51577
Cable: 31231 TEIL Nigeria
Cable: THETEL Ibadan
The Electronics Instrumentations
Ltd.
144 Agege Motor Road, Mushin
P.O. Box 6645
Lagos
Cable: THETEL Lagos

PAKISTAN
Mushko & Company, Ltd.
Osman Chambers
Abdullah Haroon Road
Karachi-3
Tel: 511027, 512927
Telex: KR894
Cable: COOPERATOR Karachi
Mushko & Company, Ltd.
385, Satellite Town
Rawalpindi
Tel: 41924
Cable: FEMSA Rawalpindi

PHILIPPINES
The Online Advanced Systems
Corporation
Filinvest Bldg
11th Floor, Ayala Ave
Makati, Rizal
Tel: 86-40-81, ext. 223, 263
Telex: 3274 ONLINE
Rhodesia
Field Technical Sales
45 Kelvin Road North
P.O. Box 3458
Salisbury
Tel: 705231 (5 lines)
Telex: RH 4122

SINGAPORE
Hewlett-Packard Singapore
(Pty.) Ltd.
Blk. 2, 8th Floor, Jalan
Bukit Merah
Redhill Industrial Estate
Alexandra P.O. Box 56,
Singapore 3
Tel: 833022
Telex: HPSG RS 21486
Cable: HEWPACK, Singapore

SOUTH AFRICA
Hewlett-Packard South Africa
(Pty.) Ltd.
Private Bag Wendywood
Sandton, Transvaal 2144
Hewlett-Packard House
Daphne Street, Wendywood,
Sandton, Transvaal 2144
Tel: 802-100016
Telex: SA43-4782JH
Cable: HEWPACK JOHANNESBURG
Hewlett-Packard South Africa
(Pty.) Ltd.
P.O. Box 120
Howard Place, Cape Province, 7450
Pine Park Center, Forest Drive,
Pinelands, Cape Province, 7405
Tel: 53-7955 thu 9
Telex: 57-0006
Hewlett-Packard South Africa
(Pty.) Ltd.
P.O. Box 37099
Overport, Durban 4067
641 Ridge Road, Durban
Durban, 4001
Tel: 88-7478, 88-1080, 88-2520
Telex: 6-7954
Cable: HEWPACK

TAIWAN
Hewlett-Packard Far East Ltd.
Taiwan Branch
39 Chung Shiao West Road
Sec. 1, 7th Floor
Taipei
Tel: 389160, 1, 2, 3
Telex: 21824 HEWPACK
Cable: HEWPACK TAIPEI
Hewlett-Packard Far East Ltd.
Taiwan Branch
68-2, Chung Cheng 3rd. Road
Kaohsiung
Tel: (07) 242318-Kaohsiung
Analytical Only
San Kwang Instruments Co., Ltd.
No. 20, yang Sun Road
Taipei, 100
Tel: 371571-4 (4 lines)
Telex: 22894 SANKWANG
Cable: SANKWANG TAIPEI

TANZANIA
Medical Only
International Aeradio (E.A.) Ltd.
P.O. Box 861
Dar es Salaam
Tel: 21251 Est. 265
Telex: 41030
THAILAND
UNIMESA Co., Ltd.
Elcom Research Building
Bangkok Sukumvit Ave
Bangkok
Tel: 93287 93038K
Cable: UNIMESA Bangkok

UGANDA
Medical Only
International Aeradio (E.A.) Ltd.
P.O. Box 2577
Kampala
Tel: 54388
Cable: INTAERIO Kampala
ZAMBIA
R.J. Tilbury (Zambia) (Pty.) Ltd.
P.D. Box 2792
Lusaka
Tel: 73793
Cable: ARJAYTEE, Lusaka

OTHER AREAS NOT LISTED. CONTACT:
Hewlett-Packard International
3200 Hillview Ave
Palo Alto, California 94304
Tel: (415) 493-1501
Telex: 910-373-1267
Cable: HEWPACK Palo Alto
Tel: 034-8300, 034-8493

CANADA

ALBERTA
Hewlett-Packard (Canada) Ltd.
11748 Kingsway Ave.
Edmonton T5G 0K5
Tel: (403) 452-3670
TWX: 610-831-2431 EOTH
Hewlett-Packard (Canada) Ltd.
915-42 Avenue S.E. Suite 102
Calgary T2G 1Z1
Tel: (403) 287-1672
TWX: 610-621-641

BRITISH COLUMBIA
Hewlett-Packard (Canada) Ltd.
837 E. Cordova Street
Vancouver V6A 3R2
Tel: (604) 254-0531
TWX: 610-922-5059 VCR

MANITOSA
Hewlett-Packard (Canada) Ltd.
513 Century St.
Winnipeg R3H 0L8
Tel: (204) 786-5871
TWX: 610-671-3531

NOVA SCOTIA
Hewlett-Packard (Canada) Ltd.
800 Windmill Road
Pointe Claire H9R 1G7
Tel: (613) 225-6530
Tel: (902) 469-8298
TWX: 610-271-4482 HFX

ONTARIO
Hewlett-Packard (Canada) Ltd.
1265 Woodward Dr.
Pointe Claire H9R 1G7
Tel: (613) 225-6530
Tel: (902) 469-8298
Hewlett-Packard (Canada) Ltd.
6877 Goreway Drive
Mississauga L4V 1M8
Tel: (416) 678-9430
TWX: 610-492-4246

QUEBEC
Hewlett-Packard (Canada) Ltd.
1265 Woodward Dr.
Pointe Claire H9R 1G7
Tel: (613) 225-6530
Tel: (902) 469-8298
TWX: 610-271-4482 HFX

Hewlett-Packard (Canada) Ltd.
2376 Galvani Street
St. Foy G1N 4G4
Tel: (418) 888-8710
TWX: 610-571-5525

FOR CANADIAN AREAS NOT LISTED:
Contact Hewlett-Packard (Canada)
Ltd. in Mississauga

CENTRAL AND SOUTH AMERICA

ARGENTINA
Hewlett-Packard Argentina
S.A.
Av. Leandro N. Alem 822 - 12°
1001 Buenos Aires
Tel: 37-4461/62/63/64
Telex: Public Booth

BOLIVIA
Stambuk & Mark (Bolivia) Ltda
Av. Manscara, Santa Cruz 1342
La Paz
Tel: 40626, 53163, 52421
Telex: 3560014
Cable: BUKMAR

BRAZIL
Hewlett-Packard do Brasil
I.E.C. Ltda.
Rua Frei Caneca,
1140/52 Bela Vista
01307 São Paulo-SP
Tel: 288-71-11, 287-81-20,
287-61-93
Telex: 391-12-3602 HPBR-BR
Cable: HEWPACK São Paulo
Hewlett-Packard do Brasil
I.E.C. Ltda.
Rua Padre Cegalas, 32
90000 Porto Alegre-RS
Tel: (0512) 22-2998, 22-5621
Cable: HEWPACK porto Alegre

Hewlett-Packard do Brasil
I.E.C. Ltda.
Rua Siqueira Campos, 53, 4°
andar-Copacabana
20000-Rio de Janeiro-GB
Tel: 257-80-94-DDD (021)
Telex: 39-212-905 HEWP-BR
Cable: HEWPACK
Rio de Janeiro

CHILE
Calcagni & Metcalfe Ltda.
Alameda 580-Of. 807
Casilla 2118
Santiago, 1
Tel: 398613
Telex: 3520001 CALMET
Cable: CALMET Santiago

Medical Only
General Machinery Co., Ltda.
Paraguay 494
Casilla 13910
Santiago
Tel: 31123, 31124
Cable: GEMCO Santiago

COLOMBIA
Instrumentación
Henrik A. Langebaek & Kier S.A.
Carrera 7 No. 48-75
Apartado Aéreo 6287
Bogotá, D.E.
Tel: 69-58-77
Cable: AARIS Bogotá
Telex: 044-400

COSTA RICA
Científica Costarricense S.A.
Calle Central, Avenidas 1 y 3
Apartado 10159
San José
Tel: 21-86-13
Cable: GALGUR San José

ECUADOR
Medical Only
A.F. Viscaino Compañía Ltda.
A.F. Rio Amazonas No. 239
P.O. Box 2925
Quito
Tel: 242-150-247-033/034
Cable: Astor Quito

Calculators Only
Computadoras y Equipos
Electrónicos
P.O. Box 2695
990 Toledo (y Cordero)
Quito
Tel: 525-982
Telex: 02-2113 Sagita Ed
Cable: Sagita-Quito

EL SALVADOR
Instrumentación y Procesamiento
Electrónico de el Salvador
Bulevar de los Heroes 11-48
San Salvador
Tel: 252787

GUATEMALA
IPESA
Avenida La Reforma 3-48,
Zona 9
Guatemala City
Tel: 63627, 64786
Telex: 4192 Teletro Gu

MEXICO
Hewlett-Packard Mexicana,
S.A. de C.V.
Torres Adalid No. 21, 11° Piso
Col. del Valle
Mexico 12, D.F.
Tel: 606-676
Telex: 01-74-42-32
Telex: 017-74-507

Hewlett-Packard Mexicana,
S.A. de C.V.
Ave. Constitución No. 2184
Monterrey, N.L.
Tel: 48-71-32, 48-71-84
Telex: 038-843

NICARAGUA
Roberto Terán G.
Apartado Postal 689
Edificio Terán
Managua
Tel: 25114, 23412, 23454
Cable: ROTERAN Managua
Cable: ROTERAN Managua

PARAGUAY
Z.J. Mamed S.R.L.
División: Aparatos y Equipos
Médicos
División: Aparatos y Equipos
Científicos y de Investigación
P.O. Box 676
Chile, 82, Edificio Victoria
Asunción
Tel: 4-5069, 4-6272
Cable: RAMEL

PERU
Compañía Electro Médica S.A.
Los Flamencos 145
San Isidro Casilla 1030
Lima 1
Tel: 41-3703
Cable: ELMED Lima

PUERTO RICO
Hewlett-Packard Inter-Américas
Puerto Rico Branch Office
P.O. Box 29081
65th Inf. Station
San Juan 00929
Calle 272, Ur. Country Club
Carolina 00639
Tel: (809) 762-7355/7455/7655
Telex: HPIC-PR 3450514

URUGUAY
Pablo Ferrando S.A.
Comercial e Industrial
Avenida Italia 277
Casilla de Correo 370
Montevideo
Tel: 40-3102
Cable: RADILUM Montevideo

VENEZUELA
Hewlett-Packard de Venezuela
C.A.
Apartado 50933 Caracas 05
Edificio Segre
Tercera Transversal
Los Ruices Norte
Caracas 07
Tel: 35-01-07, 35-00-84,
35-00-65, 35-00-31
Cable: 25146 HEWPACK
Telex: HEWPACK Caracas

FOR AREAS NOT LISTED. CONTACT:
Hewlett-Packard
Inter-Américas
3200 Hillview Ave
Palo Alto, California 94304
Tel: (415) 493-1501
Telex: 910-373-1260
Cable: HEWPACK Palo Alto
Tel: 034-8300, 034-8493

EUROPE, NORTH AFRICA AND MIDDLE EAST

- AUSTRIA**
Hewlett-Packard Ges m b H
Handelskai 52
P.O. Box 7
A-1205 Vienna
Tel: (0222) 35 16 21 to 27
cable: HEWPACK Vienna
Telex: 75923 hepaw a
- BELGIUM**
Hewlett-Packard Benelux
S.A./N.V.
Avenue de Col-Vert, 1.
(Groenkraaglaan)
B-1170 Brussels
Tel: (02) 672 22 40
Cable: PALOBEN Brussels
Telex: 23 494 paloben bru
- CYPRUS**
Kyprionics
19, Gregorios & Xenopoulos Rd.
P.O. Box 1152
CY-Nicosia
Tel: 45628/29
Cable: KYPRONICS PANDEHIS
Telex: 3018
- CZECHOSLOVAKIA**
Vývojová a Provozní Závadna
Výzkumných Ústavů v Bechovicích
CSSR-25097
Bechovice u Prahy
Tel: 89 93 41
Telex: 121333
- DDR**
Entwicklungs-labor der TU Dresden
Forschungsinstitut Meinsberg
DDR-7305
Waldheim/Meinsberg
Tel: 37 667
Telex: 518741
- DENMARK**
Hewlett-Packard A/S
Datavej 52
DK-3460 Birkerød
Tel: (02) 81 66 40
Cable: HEWPACK AS
Telex: 166 40 hpas
- Hewlett-Packard A/S
Navegvej 1
DK-8600 Silkeborg
Tel: (06) 82 71 66
Telex: 166 40 hpas
Cable: HEWPACK AS
- FINLAND**
Hewlett-Packard OY
Nahkahuontie 5
P.O. Box 6
SF-00211 Helsinki 21
Tel: 6923031
Cable: HEWPACKOY Helsinki
Telex: 12-1563
- FRANCE**
Hewlett-Packard France
Quartier de Courtaouef
Boite Postale No. 6
F-91401 Orsay Cédex
Tel: (1) 90 78 25
Cable: HEWPACK Orsay
Telex: 600048
- Hewlett-Packard France
"Le Saquin"
Chemin des Mouilles
Boite Postale No. 12
F-69130 Ecully
Tel: (78) 33 61 25
Cable: HEWPACK Ecully
Telex: 310617
- Hewlett-Packard France
Agence Régionale
Pérence de la Cépérie
Chemin de la Cépérie, 20
F-31300 Toulouse-Le Mirail
Tel: (61) 40 11 12
Cable: HEWPACK 51957
Telex: 510957
- Hewlett-Packard France
Agence Régionale
Aéroport principal de
Marseille-Margiane
F-13721 Margiane
Tel: (91) 89 12 36
Cable: HEWPACK MARGN
Telex: 410770
- Hewlett-Packard France
Agence Régionale
63, Avenue de Rochester
Boite Postale
F-35014 Rennes Cédex
Tel: (90) 36 33 21
Cable: HEWPACK 74912
Telex: 740912
- Hewlett-Packard France
Agence Régionale
74, Allée de la Robertsau
F-67000 Strasbourg
Tel: (88) 35 23 20/21
Telex: 890141
Cable: HEWPACK STRBG
Telex: 410770
- Hewlett-Packard France
Agence Régionale
Centre Vauban
201, rue Colbert
Entrée A
F-95000 Lille
Tel: (20) 51 44 14
Telex: 820744
- GERMAN FEDERAL REPUBLIC**
Hewlett-Packard GmbH
Vertreterzentrale Frankfurt
Bernstrasse 117
Postfach 560 140
D-6000 Frankfurt 56
Tel: (061) 50 04-1
Cable: HEWPACKSA Frankfurt
Telex: 04 13249 hpffmd
Hewlett-Packard GmbH
Technisches Büro Böblingen
Herrenbergerstrasse 110
D-7030 Böblingen, Württemberg
Tel: (07031) 667-1
Cable: HEPAK Böblingen
Tel: 07265739 bbn
Hewlett-Packard GmbH
Technisches Büro Ouesseldorf
Emanuel-Leutze-Str. 1 (Seester)
D-4000 Düsseldorf
Tel: (0211) 59 71-1
Telex: 08586 533 hpdd d
Hewlett-Packard GmbH
Technisches Büro Hamburg
Wendensstrasse 23
D-2000 Hamburg 1
Tel: (040) 24 13 83
Cable: HEWPACKSA Hamburg
Telex: 21 63 032 hpnh d
Hewlett-Packard GmbH
Technisches Büro Hannover
Meliandorfer Strasse 3
D-3000 Hannover-Kleefeld
Tel: (0511) 55 60 46
Telex: 092 3259
- Hewlett-Packard GmbH
Technisches Büro Nuremberg
Neumeyer Str. 90
D-8500 Nuremberg
Tel: (0911) 56 30 83/85
Telex: 0623 860
- Hewlett-Packard GmbH
Technisches Büro München
Unterhachinger Strasse 28
ISAR Center
D-8012 Ottobrunn
Tel: (089) 601 30 81/7
Cable: HEWPACKSA München
Telex: 0524985
- Hewlett-Packard GmbH
Technisches Büro Berlin
Keith Strasse 2-4
D-1000 Berlin 30
Tel: (030) 24 90 88
Telex: 18 3405 hpblin d
- GREECE**
Kostas Karayannis
18, Ermou Street
GR-Athens 126
Tel: 323731
Cable: RAKAR Athens
Telex: 21 59 62 rkar gr
Analytical Only
"INTECO"
G. Papatheassiou & Co.
Marni 17
GR - Athens 103
Tel: 522 1915
Cable: INTEKNIKA Athens
Telex: 21 5329 INTE GR
- Medical Only
Technomed Hellas Ltd.
52, Skoula Street
GR - Athens 135
Tel: 626 972 663 930.614 959
Cable: ETALAK Athens
Telex: 21-4693 ETAL GR
- HUNGARY**
MTA
Műszaki és Mérési Technikai
Szolgálat
Lenin Krt. 67
1391 Budapest VI
Tel: 42 03 38
Telex: 22 51 14
- ICELAND**
Medical Only
Eidring Trading Company Inc.
Halnarhvoli - Tryggvatoftu
IS-Reykjavik
Tel: 568 20
Cable: ELDING Reykjavik
Cable: ELDING Reykjavik
- IRAN**
Hewlett-Packard Iran Ltd.
Mir Emad Avenue
14th Street No. 13
P.O. Box 41/2419
IR-Tehran
Tel: 85 10 82/86
Telex: 21 25 74 Khm ir
- IRELAND**
Hewlett-Packard Ltd.
King Street Lane
GB-Winnerah, Wokingham
Berks. RG11 5AR
Tel: (0734) 78 47 74
Telex: 847178/848179
- ITALY**
Hewlett-Packard Italiana S.p.A.
Casella postale 3645
I-20100 Milano
Tel: (2) 6251 (10 lines)
Cable: HEWPACKIT Milano
Telex: 32046
- Hewlett-Packard Italiana S.p.A.
Via Pietro Maroncelli 40
(ang. Via Visentini)
I-35100 Padova
Tel: (089) 66 48 88
Telex: 41612 Hewpacki
- Medical only
Hewlett-Packard Italiana S.p.A.
Via d'Aghardi, 7
I-56100 Pisa
Tel: (050) 2 32 04
Telex: 32046 via Milano
- Hewlett-Packard Italiana S.p.A.
Via G. Armetlini 10
I-00143 Roma
Tel: (06) 54 69 61
Telex: 61514
Cable: HEWPACKIT Roma
- Hewlett-Packard Italiana S.p.A.
Via San Quintino, 46
I-10121 Torino
Tel: (011) 52 82 64/54 84 68
Telex: 32046 via Milano
- Medical/Calculators Only
Hewlett-Packard Italiana S.p.A.
Via Principe Nicola 43 G/C
I-95126 Catania
Tel: (095) 37 05 04
- Hewlett-Packard Italiana S.p.A.
Via Amerigo Vespucci, 9
I-80142 Napoli
Tel: (081) 33 77 11
- Hewlett-Packard Italiana S.p.A.
Via E. Masi, 9/B
I-40137 Bologna
Tel: (051) 30 78 87
- KUWAIT**
Al-Khaldiya Trading &
Contracting Co.
P.O. Box 3531
Kuwait
Tel: 42 49 10
Cable: VISCOUNT
- LUXEMBURG**
Hewlett-Packard Benelux
S.A./N.V.
Avenue du Col-Vert, 1.
(Groenkraaglaan)
B-1170 Brussels
Tel: (02) 672 22 40
Cable: PALOBEN Brussels
Telex: 23 494
- MOROCCO**
Gerep
90, Blvd. Brahim Roudani
Casablanca
Tel: 25-16-76/25-90-99
Cable: Gerep-Casa
Telex: 23738
- NETHERLANDS**
Hewlett-Packard Benelux N.V.
Van Heuven Goedhartlaan 121
P.O. Box 667
NL-Amstelveen 1134
Tel: (020) 47 20 21
Cable: PALOBEN Amsterdam
Telex: 13 216 hepa nl
- NORWAY**
Hewlett-Packard Norge A/S
Nesveien 13
Tel: (3) 203 6200 (5 lines)
Telex: 52603 hpbe e
- N-1344 Hælum
Tel: (02) 53 83 60
Telex: 16621 hpnas n
- POLAND**
Biuro Informatyki Technicznej
Hewlett-Packard
Ul. Sławków 2 6P
00-950 Warszawa
Tel: 39 67 43
Telex: 81 24 53 hepa pl
- UNIPAN
Zakład Doswiadczalny
Budowy Aparatury Naukowej
Ul. Krajowej Rady
Narodowej 51/55
00-800 Warszawa
Tel: 20 82 21
Telex: 81 46 48
Zakłady Naprawcze Sprzetu
Medycznego
Plac Komuny Paryskiej 6
90-007 Lodz
Tel: 334-41, 337-83
- PORTUGAL**
Teletra-Empresa Técnica de
Equipamentos Electricos S a r.l.
Rua Rodrigo da Fonseca 103
P.O. Box 2531
P-Lisbon 1
Tel: (19) 68 60 72
Cable: TELETRA Lisbon
Telex: 12598
- Medical only
Mundinter
Intercomercio Mundial de Comercio
S.a.l.
Av. A.A. de Aguiar 138
P.O. Box 2761
P.L. Lisbon
Tel: (19) 53 21 31/7
Cable: INTERCAMBID Lisbon
- RUMANIA**
Hewlett-Packard Reprezentantia
BD N. Balcescu 16
Bucharest
Tel: 158023/138885
Telex: 10440
I.I.R.U.C.
Intreprinderea Pentru
Intretinerea
Str. Reparatara Utilajelor de Calcul
B-dul 9 Decembrie 1918
Bucharest, Sectorul 2
Tel: 12 64 30
Telex: 01183716
- SAUDI ARABIA**
Modern Electronic Establishment
King Abdul Aziz Str. (Head office)
P.O. Box 1228
Jeddah
Tel: 31173-322201
Cable: ELECTRA
P.O. Box 2728 (Service center)
Riyadh
Tel: 62596-66232
Cable: RAOUFCO
- SPAIN**
Hewlett-Packard Española, S.A.
Jerez No. 3
E-Madrid 16
Tel: (1) 456 26 00 (10 lines)
Telex: 23515 hpe
- Hewlett-Packard Española, S.A.
Milanesado 21-23
E-Barcelona 17
Tel: (3) 203 6200 (5 lines)
Telex: 52603 hpbe e
- Hewlett-Packard Española, S.A.
Av Ramón y Cajal, 1-9°
(Edificio Sevilla I)
E-Seville 5
Tel: 64 44 54/58
Hewlett-Packard Española S.A.
Edificio Albia II 7° B
E-Bilbao-1
Tel: 23 83 06/23 82 06
Calculators Only
Hewlett-Packard Española S.A.
Gran Vía Fernando El Católico, 67
E-Valencia-8
Tel: 326 67 28/326 65 55
- SWEDEN**
Hewlett-Packard Sverige AB
Engelstevägen 3
Fack
S-161 20 Bromma 20
Tel: (08) 730 05 50
Cable: MEASUREMENTS
Stockholm
Telex: 10721
Hewlett-Packard Sverige AB
Frdalsgatan 30
S-421 32 Västra Frölunda
Tel: (031) 49 09 50
Telex: 10721 via Bromma Office
- SWITZERLAND**
Hewlett-Packard (Schweiz) AG
Zürcherstrasse 20
P.O. Box 307
CH-8952 Schlieren-Zürich
Tel: (01) 730 52 40
Cable: HPAG CH
Telex: 53933 hpag ch
- Hewlett-Packard (Schweiz) AG
9, Chemin Louis-Pictet
CH-1214 Vernier-Geneva
Tel: (022) 41 49 50
Cable: HEWPACKAG Geneva
Telex: 27 333 hpag ch
- SYRIA**
Medical/calculator only
Sawah & Co.
Place Azmé
B.P. 2308
SYR-Damascus
Tel: 16367, 19687, 14268
Cable: SAWAH, Damascus
- TURKEY**
Telekom Engineering Bureau
P.O. Box 437
Beşoglu
TR-Istanbul
Tel: 49 40 40
Cable: TELEMATIK Istanbul
Telex: 23609
- Medical only
E.M.A.
Mühendislik Kolektif Sirketi
Adakale Sokak 41/6
TR-Ankara
Tel: 175622
Analytical only
Yilmaz Özyürek
Milk Mudafaa Cad No. 16/6
Kızılay
TR-Ankara
Tel: 25 03 09
Telex: 42576 Özek tr
- UNITED KINGDOM**
The Graton
Stamford Road
GB-Altrincham
Cheshire WA14 1DQ
Tel: (061) 9289021
Cable: Hewpke Manchester
Telex: 660686
- Hewlett-Packard Ltd.
Lygon Court
Dudley Road
GB-Halesowen, Worcs
Tel: (021) 550 7053
Telex: (021) 550 7273
- Hewlett-Packard Ltd.
Wedge House
799, London Road
GB-Thornton Heath
Surrey CR4 6XL
Tel: (01) 6840105
Telex: 946825
- Hewlett-Packard Ltd.
c/o Makro
Service Wholesale Centre
West Industrial Estate
Washington
GB-New Town, County Durham
Tel: Washington 464001 ext. 57/58
Tel: 294-2024
- USSR**
Hewlett-Packard Representative
Office USSR
Pokrovsky Boulevard 4/17, KV 12
Moscow 101900
Tel: 294-2024
Telex: 7825 hepaw su
- YUGOSLAVIA**
Iskra-standard/Hewlett-Packard
Mikloševića 38/VI
61000 Ljubljana
Tel: 31 58 79/32 16 74
Telex: 31300

UNITED STATES

- ALABAMA**
8290 Whitesburg Dr., S.E.
P.O. Box 4207
Huntsville 35802
Tel: (205) 881-4591
Medical only
228 W. Valley Ave.,
Room 220
Birmingham 35209
Tel: (205) 942-2081
- ARIZONA**
2336 E. Magnolia St
Phoenix 85034
Tel: (602) 244-1361
2424 East Aragon Rd.
Tucson 85706
Tel: (602) 294-3148
- ARKANSAS**
Medical Service Only
P.O. Box 5646
Brady Station
Little Rock 72205
Tel: (501) 664-8773
- CALIFORNIA**
1430 East Orangethorpe Ave
Fullerton 92631
Tel: (714) 870-1000
3939 Lankershim Boulevard
North Hollywood 91604
Tel: (213) 877-1282
TWX: 910-499-2170
6305 Arizona Place
Los Angeles 90045
Tel: (213) 649-2511
TWX: 910-328-6147
- Los Angeles**
Tel: (213) 776-7500
3003 Scott Boulevard
Santa Clara 95050
Tel: (408) 249-7000
TWX: 910-338-0518
- Colorado**
5600 South Ulster Parkway
Englewood 80110
Tel: (303) 771-3455
- CONNECTICUT**
12 Lunar Drive
New Haven 06525
Tel: (203) 389-6551
TWX: 710-465-2029
- FLORIDA**
P.O. Box 24210
2806 W. Oakland Park Blvd.
Ft. Lauderdale 33307
Tel: (305) 371-2020
- Jackonville**
Medical Service Only
Tel: (904) 725-6333
P.O. Box 13910
6177 Lake Ellenor Dr.
Orlando 32809
Tel: (305) 859-2900
P.O. Box 12826
Pensacola 32575
Tel: (904) 434-3081
- GEORGIA**
P.O. Box 105005
Atlanta 30348
Tel: (404) 955-1500
TWX 810-766-4890
Medical Service Only
"Augusta" 30903
Tel: (404) 736-0592
- HAWAII**
2875 So. King Street
Honolulu 96814
Tel: (808) 955-4455
- ILLINOIS**
5500 Howard Street
Skokie 60076
Tel: (312) 677-0400
TWX: 910-223-3613
Effective Nov. 1, 1976
35201 Tolliver Dr.
Rolling Meadows 60008
Tel: (312) 255-9800
TWX: 910-687-2260
- INDIANA**
7301 North Shadeland Ave.
Indianapolis 46250
Tel: (317) 842-1000
TWX: 810-260-1796
- IOWA**
1902 Broadway
Iowa City 52240
Tel: (319) 338-9466
Night: (319) 338-9467
- KENTUCKY**
Medical Only
Atkinson Square
3901 Atkinson Dr.,
Suite 207
Louisville 40218
Tel: (502) 456-1573
- LOUISIANA**
P.O. Box 840
3239 Williams Boulevard
Lafayette 70502
Tel: (504) 721-6201
- MARYLAND**
6707 Whitestone Road
Baltimore 21207
Tel: (301) 944-5400
Tel: (301) 786-9157
2 Choke Cherry Road
Rockville 20850
Tel: (301) 948-6370
Tel: (301) 828-9684
- MASSACHUSETTS**
32 Hartwell Ave.
Lexington 02173
Tel: (617) 861-8960
TWX: 910-326-6904
- MICHIGAN**
23855 Research Drive
Farmington Hills 48024
Tel: (313) 476-6400
TWX: 810-242-2900
- MINNESOTA**
2400 N. Prior Ave.
Poughkeepsie 55113
Tel: (612) 636-0700
TWX: 910-563-3734
- MISSISSIPPI**
"Jackson"
Medical Service Only
Tel: (601) 982-9363
- MISSOURI**
11131 Colorado Ave.
Kansas City 64137
Tel: (816) 575-8000
TWX: 910-771-2087
- 148 Weldon Parkway
Maryland Heights 63043
Tel: (314) 587-1455
TWX: 910-764-0830
- NEBRASKA**
Medical Only
7171 Mercy Road
Suite 10
Omaha 68106
Tel: (402) 392-0948
- NEW JERSEY**
W. 120 Century Rd.
Paramus 07652
Tel: (201) 265-5000
TWX: 710-990-4951
- NEW MEXICO**
P.O. Box 11634
Station E
11300 Lomas Blvd., N.E.
Albuquerque 87123
Tel: (505) 292-1330
TWX: 910-989-1185
- 156 Wyatt Drive
Las Cruces 88001
Tel: (505) 526-2485
TWX: 910-983-0550
- NEW YORK**
6 Automation Lane
Computer Park
Albany 12205
Tel: (518) 458-1550
TWX: 710-441-8270
- 201 South Avenue
Poughkeepsie 12601
Tel: (914) 454-7330
TWX: 510-248-0012
- 39 Saginaw Drive
Rochester 14623
Tel: (716) 473-9500
TWX: 510-253-5981
- 5858 East Molloy Road
Syracuse 13211
Tel: (315) 454-2486
TWX: 710-541-0482
- 1 Crossways Park West
Woodbury 11797
Tel: (516) 921-0300
TWX: 710-990-4951
- NORTH CAROLINA**
P.O. Box 5188
1923 North Main Street
High Point 27262
Tel: (919) 885-8101
- OHIO**
16500 Sprague Road
Cleveland 44130
Tel: (216) 243-7300
TWX: 810-423-9431
- 330 Progress Rd.
Dayton 45449
Tel: (513) 859-3202
TWX: 810-474-2818
- 1041 Kingsmill Parkway
Columbus 43229
Tel: (614) 436-1041
- OKLAHOMA**
P.O. Box 32008
Oklahoma City 73132
Tel: (405) 721-0200
- OREGON**
17890 SW Lower Boones
Ferry Road
Tualatin 97062
Tel: (503) 620-3350
TWX: 710-441-8270
- 201 South Avenue
Poughkeepsie 12601
Tel: (914) 454-7330
TWX: 510-248-0012
- 39 Saginaw Drive
Rochester 14623
Tel: (716) 473-9500
TWX: 510-253-5981
- 5858 East Molloy Road
Syracuse 13211
Tel: (315) 454-2486
TWX: 710-541-0482
- 1 Crossways Park West
Woodbury 11797
Tel: (516) 921-0300
TWX: 710-990-4951
- PENNSYLVANIA**
111 Zeta Drive
Pittsburgh 15238
Tel: (412) 882-0400
TWX: 710-795-3124
- 1021 8th Avenue
King of Prussia Industrial Park
King of Prussia 19406
Tel: (215) 265-7000
TWX: 510-265-2670
- SOUTH CAROLINA**
6941 O.N. Trumbull Road
Columbia 29250
Tel: (803) 782-6493
- TENNESSEE**
"Knoxville"
Medical Service Only
Tel: (615) 523-5022
- "Nashville"
Medical Service Only
Tel: (615) 244-5448
- TEXAS**
P.O. Box 1270
201 E. Arapaho Rd.
Richardson 75080
Tel: (214) 231-6101
P.O. Box 27409
6300 Westpark Drive
Suite 100
Houston 77027
Tel: (713) 781-6000
205 Billy Mitchell Road
San Antonio 78225
Tel: (512) 434-8241
- UTAH**
2160 South 3270 West Street
Salt Lake City 84119
Tel: (801) 487-0715
- VIRGINIA**
Medical Only
P.O. Box 12778
No. 7 Koper Exec. Center
Suite 212
Norfolk 23502
Tel: (804) 497-1026/7
- P.O. Box 9854
2014 Hungarty Springs Road
Richmond 23228
Tel: (804) 285-3431
- WASHINGTON**
Bellefield Office Pk.
1203-114th Ave. S.E.
Bellevue 98004
Tel: (206) 454-3971
TWX: 910-443-2446
- WEST VIRGINIA**
Medical/Analytical Only
Charleston
Tel: (304) 345-1640
- WISCONSIN**
9004 West Lincoln Ave.
West Allis 53227
Tel: (414) 541-0550

FOR U.S. AREAS NOT LISTED:
Contact the regional office
nearest you: Atlanta, Georgia,
North Hollywood, California,
Rockville, Maryland, Rolling Meadows,
Illinois. Their complete
addresses are listed above.

***Service Only**



MANUAL PART NO. 12960-90001
MICROFICHE PART NO. 12960-90002

PRINTED IN U.S.A.

OPERATING AND SERVICE MANUAL

13210A

**DISC DRIVE INTERFACE KIT
(FOR THE 2100 SERIES COMPUTERS)**



Printed-Circuit Assemblies

13210-60000, Series 1211, 1249, 1438, 1446
13210-60004, Series 1211, 1232

Note

This manual is directly applicable to interface kits with serial prefixes shown above and can also be made applicable to interface kits with serial prefixes 1135 and 1138 by incorporating the appropriate changes listed in the appendix at the back of this manual.

CONTENTS

Section	Page	Section	Page
I GENERAL INFORMATION			
1-1. Introduction	1-1	3-56. Data Protect	3-5
1-3. General Description	1-1	3-58. Drive Unsafe	3-5
1-5. Interface Kit Contents	1-1	3-60. Overrun	3-5
1-7. Identification	1-1	3-62. First Status	3-5
1-12. Specifications	1-1	3-64. Programming Considerations	3-6
		3-65. Write Checking	3-6
II INSTALLATION		3-67. Disc Initialization	3-6
2-1. Introduction	2-1	3-70. Error Recovery Procedures	3-6
2-3. Unpacking and Initial Inspection	2-1	3-77. Typical Program	3-6
2-6. Installation	2-1		
		IV THEORY OF OPERATION	
III PROGRAMMING		4-1. Introduction	4-1
3-1. Introduction	3-1	4-3. Functional Description	4-1
3-3. Disc Drive Characteristics	3-1	4-4. Power On	4-1
3-6. Command Descriptions	3-1	4-7. Command Execution	4-1
3-11. Status Check	3-2	4-11. Data Transfer Execution	4-1
3-13. Write Data	3-2	4-17. Detailed Circuit Description	4-2
3-17. Read Data	3-2	4-18. Command Execution	4-2
3-20. Seek Record	3-2	4-21. Data Transfer Operations	4-2
3-24. Refine Sector	3-3	4-25. Write Operations	4-3
3-27. Check Data	3-3	4-29. Read Operations	4-3
3-31. Initialize Data	3-4		
3-35. Address Record	3-4	V MAINTENANCE	
3-36. Status Descriptions	3-4	5-1. Introduction	5-1
3-40. Any Error	3-4	5-3. Preventive Maintenance	5-1
3-42. Data Error	3-4	5-5. Calibration	5-1
3-44. Drive Busy	3-5	5-8. Troubleshooting	5-1
3-46. Flagged Cylinder	3-5		
3-48. Address Error	3-5	VI REPLACEABLE PARTS	
3-50. End of Cylinder	3-5	6-1. Introduction	6-1
3-52. Not Ready	3-5	6-4. Ordering Information	6-1
3-54. Seek Check	3-5		
		APPENDIX A — BACKDATING INFORMATION	

ILLUSTRATIONS

Figure	Title	Page	Figure	Title	Page
1-1.	HP 13210A Disc Drive Interface Kit	1-0	4-5.	Seek Record and Address Record Operations Flow Diagram	4-9
3-1.	Command Word Format	3-1	4-6.	Write, Read, Check Data, and Initialize Data Operations Flow Diagram	4-11
3-2.	Address Word Formats for Seek Record Command	3-3	4-7.	Status Operation Flow Diagram	4-13
3-3.	Sector Count Word Format for Check Data Command	3-3	4-8.	Read Data Separation Timing Diagram	4-15
4-1.	Sector Write Format	4-2	5-1.	Disc Interface 1 PCA Parts Location Diagram	5-3
4-2.	Data Bit Cell	4-3	5-2.	Disc Interface 1 PCA Schematic Diagram	5-5
4-3.	Disc Interface 1 PCA Block Diagram	4-5	5-3.	Disc Interface 2 PCA Parts Location Diagram	5-8
4-4.	Disc Interface 2 PCA Block Diagram	4-7	5-4.	Disc Interface 2 PCA Schematic Diagram	5-9

TABLES

Table	Title	Page	Table	Title	Page
1-1.	HP 13210A Disc Drive Interface Kit Specifications	1-1	5-3.	Disc Interface 2 PCA (13210-60000) Replaceable Parts	5-7
3-1.	Computer to Interface Commands	3-1	5-4.	Interconnecting Cable Plug-to-Plug Connections	5-11
3-2.	Status Word Bits	3-4	6-1.	HP 13210A Disc Drive Interface Kit Replaceable Parts	6-1
3-3.	Typical Assembly Language Program	3-7	6-2.	Reference Designations and Abbreviations	6-2
5-1.	Mnemonic Definitions	5-1	6-3.	Code List of Manufacturers	6-3
5-2.	Disc Interface 1 PCA (13210-60004) Replaceable Parts	5-2			



13210-1

Figure 1-1. HP 13210A Disc Drive Interface Kit

SECTION I

GENERAL INFORMATION

1-1. INTRODUCTION.

1-2. This manual provides general information, installation, programming, theory of operation, maintenance, and replaceable parts information for the HP 13210A Disc Drive Interface Kit. (See figure 1-1.)

1-3. GENERAL DESCRIPTION.

1-4. The kit includes the control circuits and cable for connecting the HP 7900 Series Disc Drives to the HP 2100 Series Computers with Direct Memory Access (DMA)* capability. The control circuits are on two plug-in printed-circuit assemblies (PCA's) which install in the I/O portion of the computer card cage. The cable connects the PCA's to the disc drive.

Note

The plug-in PCA's should only be installed in HP computers with DMA* capability. The PCA's should not be installed in the HP 2150A or 2150B Input/Output and Memory Extender, or in the HP 2151A Input/Output Extender. The extenders do not have the DMA capability necessary to operate the disc drive.

1-5. INTERFACE KIT CONTENTS.

1-6. The interface kit contains the following:

- a. Disc Interface 1 printed-circuit assembly (part no. 13210-60004).
- b. Disc Interface 2 printed-circuit assembly (part no. 13210-60000).
- c. Interconnecting Cable, 20 feet long (part no. 13210-60003).
- d. Operating and Service Manual (part no. 13210-90003).

1-7. IDENTIFICATION.

1-8. Hewlett-Packard uses five digits and a letter (00000A) to identify standard interface kits. If the designation of the kit received does not agree with the designation

on the title page of this manual, there are differences between the kit received and the kit described in this manual. These differences are explained in manual supplements available at HP Sales and Service Offices. (Addresses of these offices are listed at the back of this manual.)

1-9. Printed-circuit assembly revisions are identified by a letter, a series code, and a division code marked beneath the part number on the PCA. The letter identifies the revision of the etched trace pattern on the unloaded PCA. The four-digit series code pertains to the electrical characteristics of the loaded PCA and the positions of the components. The two-digit division code identifies the division of Hewlett-Packard that manufactured the PCA. If the series code numbers do not correspond exactly with the code numbers on the title page of this manual, the PCA's differ from those described in this manual. These differences are covered in manual supplements available at the nearest HP Sales and Service Office.

1-10. The interface cable is identified by a part number, marked on one of the plugs attached to the cable.

1-11. The manual and manual supplements are identified by title, part number, and publication date, marked on the title page of the document.

1-12. SPECIFICATIONS.

1-13. Specifications for the interface kit components are listed in table 1-1.

Table 1-1. HP 13210A Disc Drive Interface Kit Specifications

Data Rate to/from HP 7900 Series Disc Drive:	2,500,000 bits/second*
Data Rate to/from HP Computers:	156,250 words/second*
Computer Power Supply Requirements:	+5V: 4A -2V: 140 mA +12V: 60 mA -12V: 100 mA
*The high data rate requires that the computer have at least one DMA channel.	

*Dual Channel Port Controller (DCPC) in HP 21MX Series Computers.

SECTION II

INSTALLATION

2-1. INTRODUCTION.

2-2. This section provides information for unpacking, initial inspection, and installation for the HP 13210A Disc Drive Interface Kit. The computer, disc drive, and disc drive power supply should be installed and prepared for operation before installing the interface kit.

2-3. UNPACKING AND INITIAL INSPECTION.

2-4. If the disc drive interface kit is received separately from the computer, inspect the carton containing the kit before opening. If there is external evidence of damage, or if the box rattles, request that the carrier's agent be present when the carton is opened.

2-5. Inspect each component of the kit as the parts are unpacked. If the kit is damaged and fails to meet specifications, notify the carrier and the nearest HP Sales and Service Office immediately. Retain the shipping container and packing material for the carrier's inspection. The HP Sales and Service Office will arrange for repair or replacement of the damaged part without waiting for any claims against the carrier to be settled.

2-6. INSTALLATION.

2-7. Install the disc drive interface kit as follows:

- a. Set POWER switch on disc drive power supply to OFF.
- b. Set computer POWER switch to OFF.
- c. Open the computer for access to I/O card slots and install the 13210-60004 Disc Interface 1 PCA into the card slot corresponding to the desired I/O select code.
- d. Install the 13210-60000 Disc Interface 2 PCA into the next lower priority slot.
- e. Connect the double-connector end of the interface cable to the PCA's so that the DISC INTERFACE 1 portion of the connector fits onto the disc interface 1 PCA and the DISC INTERFACE 2 portion fits onto the disc interface 2 PCA.
- f. Connect the single-connector end of the interface cable to the I/O connector at the back of the disc drive with the "cable-end" of the connector routed across the back of the disc drive.

SECTION III PROGRAMMING

3-1. INTRODUCTION.

3-2. This section contains programming considerations for systems employing the HP 13210A Disc Drive Interface Kit. Included are disc drive characteristics, command and status descriptions, programming recommendations, and a typical assembly language program.

3-3. DISC DRIVE CHARACTERISTICS.

3-4. The interface kit will interface an HP 2100 Series Computer to as many as four HP 7900 Series Disc Drives using discs with the following characteristics.

- a. Each disc stores 203 cylinders of information.
- b. Each cylinder contains 96 addressable sectors, 24 on the top surface of each disc and 24 on the bottom surface of each disc.
- c. Each sector contains a sector address field and a data field. The address field contains cylinder, head, and sector numbers of the sector, and indicators for defective and protected cylinder; the data field contains as many as 128 sixteen-bit data words.

3-5. The interface kit requires two adjacent computer I/O addresses: a data channel and a command channel address. The data channel is assigned the higher priority (lower number) I/O address.

3-6. COMMAND DESCRIPTIONS.

3-7. All commands are transferred through the computer A- or B-register by an OTA/B instruction addressed to the command channel. Commands are then stored by the interface. An STC,C instruction will set the command channel Control FF and the Encode FF which will cause the interface to execute the command. When multiple OTA/B instructions are received before the STC,C instruction, the interface will execute the last OTA/B instruction issued. When the command issued is Status Check, Seek Record, or Address Record, the interface will accept another command

as soon as the required data transfer through the data channel has been completed. For all other commands, new commands must not be issued until the command channel Flag FF is set to indicate completion of the current operation.

Note

Because the interface will only respond to a positive-going Encode signal, during multiple Seek Record operations the command channel Control FF must be cleared (CLC) before a subsequent STC,C instruction will be recognized.

3-8. The command word consists of a four-bit command code and a two-bit drive select. (An additional two bits are used with the Initialize Data command.) The command word format is shown in figure 3-1. The four-bit command code contains the binary code of the command to be executed. Table 3-1 lists the commands to which the interface will respond. Commands other than those listed will cause improper operation. The two-bit drive select contains the binary code of the disc drive that is to execute the command.

Table 3-1. Computer to Interface Commands

COMMAND	BITS			
	15	14	13	12
Status Check	0	0	0	0
Write Data	0	0	0	1
Read Data	0	0	1	0
Seek Record	0	0	1	1
Refine Sector	0	1	0	1
Check Data	0	1	1	0
Initialize Data	1	0	0	1
Address Record	1	0	1	1

15	12	11	10	9	8	7	2	1	0
COMMAND CODE		NOT USED		USED WITH INITIALIZE DATA COMMAND ONLY		NOT USED		DRIVE SELECT	

Figure 3-1. Command Word Format

3-9. Commands, addresses, and status are transferred to and from the interface by an OTA/B or LIA/B instruction addressed to the data channel. Data records are transferred to and from the interface under DMA control. The data channel Encode FF must be set for data transfer to take place between the interface and disc drive. The data channel Flag FF will be set by the interface to indicate that data transfer may take place.

3-10. Drive attention status bits are transferred to the computer by an LIA/B or MIA/B instruction addressed to the command channel. Only the four lowest order bits of the data word are used. Each bit position represents a disc drive address; bit position 0 corresponds to disc drive 0, etc. Valid attention status bits are set between the setting of the command channel Flag FF and the next STC instruction to indicate that the disc drive has become ready or is completing a Seek operation.

3-11. STATUS CHECK.

3-12. The Status Check command causes the interface to assemble the status word of the desired disc drive and transfer the word to the computer through the data channel. Command execution is completed when the computer accepts the status word from the data channel; the command channel Flag FF is not set for this operation. A Status Check operation should be performed to verify proper execution of preceding operations. Status word bit definitions are given in paragraph 3-38. Status is changed only with a non-status operation.

3-13. WRITE DATA.

3-14. The Write Data command causes the interface to write data on a disc. The desired head and sector addresses must be present in the interface record address register (RAR) and the heads must be positioned over the correct cylinder before the Write Data command is issued. When the addressed sector comes into position under the head, the interface will examine the cylinder condition indicators and address information in the address field and cyclic check the entire sector. If the cylinder is not protected or defective and the address compares with the address in the RAR, the interface will increment the sector address in the RAR and initiate writing in the next sector.

3-15. The interface will write the address field and then write the data from the data channel. If the computer sends less than 128 data words, the interface will write zeros in the remainder of the sector before setting the command channel Flag FF. If the computer sends more than 128 data words, the interface will increment the sector address in the RAR and continue to write in the next sector. (Data transfer will be suspended while the interface writes the address field.) Writing will continue in this manner until the computer ends data transfer or until the interface detects an end-of-cylinder (EOC) signal or error condition, at which time the command channel Flag FF will be set. (When writing begins on the upper disc surface writing will continue in all sectors of the addressed cylinder on the bottom surface before EOC will be detected.)

3-16. If, during the examination of the address field, the defective cylinder indicator (DCI) is set, if the protected cylinder indicator (PCI) is set and the disc drive OVERRIDE switch is set to PROTECT, or if the disc drive DATA PROTECT switch for the addressed head is on, the command channel Flag FF will be set and no writing or data transfer will take place. A Status Check command should be issued to determine the cause of the termination.

3-17. READ DATA.

3-18. The Read Data command causes the interface to read the addressed record and transfer the data field to the computer. The record address must be present in the interface record address register (RAR) and the heads must be positioned over the correct cylinder before the Read Data command is issued. When the command is issued, the interface will increment the sector address in the RAR and, when the addressed sector comes into position, examine the address field for the defective cylinder indicator. The interface then compares the sector address to the address in the RAR before initiating data transfer to the computer. If the computer accepts less than 128 data words, the interface will cyclic check the remainder of the data field before setting the command channel Flag FF. If the computer will accept more than 128 data words, the interface will increment the sector address in the RAR and continue to read the next sector. (Data transfer will be suspended while the interface examines the address field.) Reading will continue until the computer stops accepting data or until the interface detects an end-of-cylinder (EOC) signal or error condition, at which time the command channel Flag FF will be set.

3-19. If, during the examination of the address field, the defective cylinder indicator (DCI) is set or the sector address does not compare with the address in the RAR, reading will continue to the end of the current sector before data transfer is halted and the command channel Flag FF is set. A Status Check operation should be performed to determine the exact cause for termination. A Status Check operation after normal termination will determine if the protected cylinder indicator was set or if the disc drive DATA PROTECT switch for the addressed head was on.

3-20. SEEK RECORD.

3-21. The Seek Record command causes the interface to execute a head-positioning operation in the addressed disc drive. When the command is issued, the interface will select the addressed disc drive and accept two 16-bit words of address information (addressed to the data channel) that are required for the head-positioning operation. When a cylinder address word has been transferred to the interface, the interface will set the data channel Flag FF to indicate acceptance of the address. The first word should contain the cylinder to which the heads should move. The second word should contain the head and sector addresses. Address word formats are shown in figure 3-2.

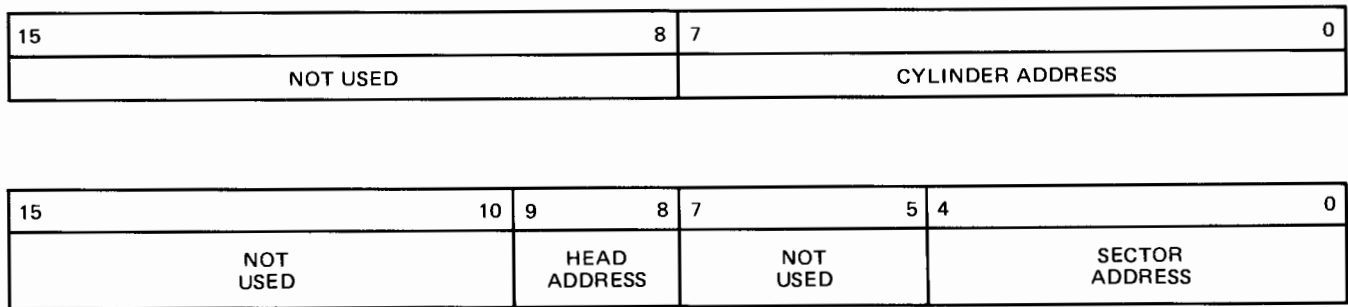

Figure 3-2. Address Word Formats for Seek Record Command

3-22. The two address words will be stored as a new record address in the interface RAR. The interface will then transfer the record address to the disc drive and initiate the head-positioning operation. Although the command channel Flag FF is not set until head positioning is complete, the interface will be free to perform other operations as soon as the second word of address information is accepted. As a result, simultaneous operations with parallel-connected disc drives are possible.

3-23. If the addressed disc drive has a head-positioning operation in progress when a new Seek Record command is issued, the heads will be positioned over the former addressed cylinder, but the latter addressed head and sector will be selected. Seek check status will be set. Seek check status will also be set if the cylinder address is greater than 202, or if the sector address is greater than 23.

3-24. REFINE SECTOR.

3-25. The Refine Sector command causes the interface to straddle-erase the addressed record as an attempt to improve the magnetic characteristics of the record. The command should only be used after retry procedures fail to recover the data. The record address must be present in the interface record address register (RAR) before the Refine Sector command is issued.

3-26. When the command is issued, the interface will increment the sector address in the RAR and straddle-erase the addressed sector; no writing or reading will take place. No examination of the address field for defective or protected cylinders or address comparison will take place. The command channel Flag FF will be set when the end of the addressed sector is reached.

3-27. CHECK DATA.

3-28. The Check Data command causes the interface to cyclic check data records of a specific number of sectors to verify recoverability of the data. The Check Data operation is similar to a Read Data operation except that no data transfer takes place. The beginning address of the cyclic check must be in the interface record address register (RAR), and the heads must be positioned over the correct cylinder before the Check Data command is issued.

3-29. When the command is issued, the interface will select the addressed disc drive and accept one 16-bit word of sector count information addressed to the data channel. The word format is shown in figure 3-3. The interface will increment the RAR and, when the addressed sector comes into position, examine the address field for the defective cylinder indicator, compare the sector address to the address in the RAR, and cyclic check the entire sector. The interface will then subtract one from the sector count and repeat the operation in the next sector until the sector count reaches zero or until the interface detects an end-of-cylinder signal or error condition, at which time the command channel Flag FF will be set.

3-30. If, during the examination of the address field, the defective cylinder indicator (DCI) is set or the sector address does not compare with the address in the RAR, the interface will halt the operation at the end of the current sector and set the command channel Flag FF. A Status Check operation should be performed to determine the exact cause for early termination. A Status Check operation after normal termination will determine if the protected cylinder indicator was set or if the disc drive DATA PROTECT switch for the addressed head was on.

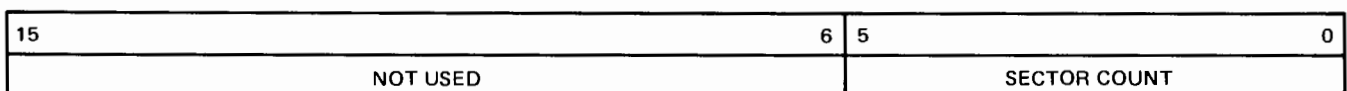

Figure 3-3. Sector Count Word Format for Check Data Command

3-31. INITIALIZE DATA.

3-32. The Initialize Data command causes the interface to initialize unwritten cylinders and to generate the defective- and protected-cylinder indicators. The command will be accepted only when the disc drive OVERRIDE switch is set to ACCESS and the DATA PROTECT switch for the selected head is off. If the OVERRIDE switch is set to PROTECT or the DATA PROTECT switch is on, the command channel Flag FF will be set and no attempt will be made to execute the command. The Initialize Data operation is similar to a Write Data operation except that the interface does not examine the first sector address field for cylinder condition indicators or address information. The desired head and sector addresses must be present in the RAR and the heads must be positioned over the correct cylinder before the Initialize Data command is issued.

3-33. When the command is issued the interface will select the addressed disc drive and increment the RAR. When the addressed sector comes into position, the interface will assemble and write the address field. The address information is that in the RAR; the cylinder condition indicator information is contained in bits 8 and 9 of the command word. If bit 8 is set, the defective cylinder indicator will be set and an incorrect address will be written in the address field; if bit 9 is set, the protected cylinder indicator will be set; if both bits 8 and 9 are set, only the defective cylinder indicator is set.

3-34. Data transfer from the computer will begin with the first data word. If the computer sends less than 128 sixteen-bit words, the interface will write zeros in the remainder of the data field. If the computer sends more than 128 data words, the interface will increment the sector address in the RAR and continue to write in the next sector. (Data transfer will be suspended while the interface writes the address field.) Writing will continue in this manner until the computer ends data transfer or until the interface detects an end-of-cylinder signal or error condition, at which time the command channel Flag FF will be set.

3-35. ADDRESS RECORD.

3-36. The Address Record command causes the interface to alter the contents of the record address register. The Address Record operation is similar to a Seek Record operation except that no operation is performed by the disc drive.

3-37. When the command is issued, the interface accepts two words of address information addressed to the data channel. The first word should contain the cylinder number to which the heads should move; the second word should contain the head and sector addresses. Address word formats are shown in figure 3-2. When the second address word has been accepted, the command channel Flag FF will be set.

3-38. STATUS DESCRIPTIONS.

3-39. Status information is transferred to the computer A- or B-register by either an LIA/B or MIA/B instruction addressed to the data channel. The status word may be

transferred any time the disc drive is selected. Individual status bits are listed in table 3-2.

3-40. ANY ERROR.

3-41. Any-error status (bit 0) is set when any of the other status bits are set, except flagged cylinder status (bit 3) or data protect status (bit 10). Any-error status is set when flagged cylinder status is set as a result of an attempt to write on a protected cylinder or initialize a cylinder with the disc drive OVERRIDE switch set to PROTECT. Any-error status is also set with flagged cylinder status when attempting to write, read, or check data on a defective cylinder (because the defective cylinder will set address error status). However, any-error status will not be set with flagged cylinder status when attempting to read or check data on a protected cylinder or attempting to write on a protected cylinder with the OVERRIDE switch set to ACCESS.

3-42. DATA ERROR.

3-43. Data error status (bit 1) is set if any of the following conditions exist:

a. During Read Data, Check Data, or Write Data if the interface fails to synchronize the data clock with the serial datum bits or if the interface detects an error when cyclic checking.

b. During Write Data, Read Data, Refine Sector, Check Data or Initialize Data if the disc drive becomes not-ready during data handling.

Data error status is cleared with execution of the Status Check command.

Table 3-2. Status Word Bits

BIT	STATUS
0	Any Error
1	Data Error
2	Drive Busy
3	Flagged Cylinder
4	Address Error
5	End of Cylinder
6	Not Ready
7	Not Used
8	Seek Check
9	Not Used
10	Data Protect
11	Drive Unsafe
12	Not Used
13	Overrun
14	First Status
15	Not Used



3-44. DRIVE BUSY.

3-45. Drive busy status (bit 2) is set when the disc drive is executing a Seek Record command (from the time the last address word is accepted until head-positioning is complete).

3-46. FLAGGED CYLINDER.

3-47. Flagged cylinder status (bit 3) is set if any of the following conditions exist:

a. During Initialize Data if the OVERRIDE switch on the disc drive is set to PROTECT.

b. During Initialize Data or Write Data if the disc drive DATA PROTECT switch for the addressed head is on.

c. During Read Data, Check Data, or Write Data if the interface detects a protected or defective cylinder indicator. If a defective cylinder is detected, address error status is also set. (Flagged cylinder status will not be set if an actual address error is detected in the same sector.)

Flagged cylinder status is cleared with the execution of the Status Check command.

3-48. ADDRESS ERROR.

3-49. Address error status (bit 4) is set during Read Data, Check Data, or the first-sector checking phase of Write Data if the sector address read does not compare with the address in the RAR or if the defective cylinder indicator is set (set with flagged cylinder status bit). Address error status is cleared with the execution of the Status Check command.

3-50. END OF CYLINDER.

3-51. End-of-cylinder status (bit 5) is set if any of the following conditions exist:

a. During the data transfer portion of Write Data, Read Data, or Initialize Data if the interface has reached the end of the data field for sector 23, head 1 or 3, and the computer signals for continuation of data transfer into the next sector.

b. During the cyclic check portion of Check Data if the interface has reached the end of the data field for sector 23, head address 1 or 3, anytime the cyclic check sector count is not zero.

End-of-cylinder status is cleared with execution of the Status Check command.

3-52. NOT READY.

3-53. Not ready status (bit 6) is set if the selected disc drive is not attached to the interface, if the disc is not up to

speed or the heads are not loaded, or if the disc drive is in an unsafe condition, in which case drive unsafe status (bit 11) will also be set. Operator intervention may be required to bring the disc drive to the ready state.

3-54. SEEK CHECK.

3-55. Seek check status (bit 8) is set if a Seek Record command has been issued and one of the following conditions exist:

a. The cylinder addressed is greater than 202.

b. The sector addressed is greater than 23.

c. A head-positioning operation is still in progress.

Seek check status is cleared by the next proper Seek Record command issued to the selected disc drive.

3-56. DATA PROTECT.

3-57. Data protect status (bit 10) is set if the disc drive DATA PROTECT switch for the addressed head is on. Write Data and Initialize Data commands will not be accepted. (Any-error and flagged cylinder status will also be set if either of these commands is issued.)

3-58. DRIVE UNSAFE.

3-59. Drive unsafe status (bit 11) is set if the disc drive checking circuits detect an unsafe condition in the disc drive access system or read/write electronics. Not ready status will also be set.

3-60. OVERRUN.

3-61. Overrun status (bit 13) is set if either of the following conditions exist:

a. During the data transfer portion of Write Data, Read Data, or Initialize Data if the computer attempts to transfer data after the maximum response time but before the interface sets the command channel Flag FF to signal operation completion. The computer DMA must respond to a data channel Flag FF signal within 5.9 microseconds.

b. During Write Data, Read Data, Check Data, or Initialize Data if a sector pulse is detected before the end of the data field of the current sector is detected.

Overrun status is cleared with the execution of a Status Check command.

3-62. FIRST STATUS.

3-63. First status (bit 14) is set when the selected disc drive goes from not-ready to ready status. First status is cleared with the execution of a Status Check command.

3-64. PROGRAMMING CONSIDERATIONS.

3-65. WRITE CHECKING.

3-66. When records are written, a program check should be performed to ensure that the record in memory was written on the disc without error and that the data can be recovered from the disc without error. When data integrity is crucial, each record should be read after being written and compared, a word at a time, with the original record in memory. This technique provides a check of both the parallel transfer between computer and interface, and serial data transfer between interface and disc drive. When data integrity is less crucial, issuance of a Check Data command will check just the serial data transfer between interface and disc drive.

3-67. DISC INITIALIZATION.

3-68. Prior to use in system, new, unwritten discs should be processed with a disc initialization program. The program should write the address field for all sectors, and should execute additional data testing to help isolate defects that may have developed after manufacture.

3-69. The additional data testing should include the following routine executed six times on each cylinder:

a. Write a fixed data pattern in all data fields of the cylinder. On each of the six passes a different data pattern should be used. The six recommended patterns are listed below in octal notation:

- (1) 0 0 0 0 0 0
- (2) 1 7 7 7 7 7
- (3) 1 2 5 2 5 2
- (4) 0 5 2 5 2 5
- (5) 1 6 2 7 4 5
- (6) 1 7 0 3 6 0

b. Execute a Check Data command 10 times on all data fields of the cylinder. If a data error occurs more than once in executing the routine on a cylinder, the cylinder should be flagged defective.

3-70. ERROR RECOVERY PROCEDURES.

3-71. Errors which occur in the storage system are often correctable by using retry procedures. Programs should include retry procedures to reduce the number of errors that will affect system operation. Paragraphs 3-72 through 3-76 list specific correctable error conditions and recommended retry procedures.

3-72. **DATA ERROR DURING READ DATA.** When a data error occurs during a Read Data operation, issue the following retry procedure.

- a. Read the record 16 times.
- b. If the error persists, issue a Seek Record command to cylinder zero, then to cylinder 202, and return to the failing cylinder.
- c. Read the record 16 times.
- d. If the error persists, issue a Refine Data command and read the record 16 times.
- e. If the error persists, terminate the retry procedure.

3-73. **DATA ERROR DURING WRITE DATA OR INITIALIZE DATA.** When a data error occurs during a Write Data or Initialize Data operation, re-issue the command once and if the error persists, terminate the retry procedure.

3-74. **ERRORS DURING WRITE CHECKING ROUTINES.** When a data error occurs during the Read Data or Check Data portion of a write-checking routine (refer to paragraph 3-65), the complete write and write-checking routine should be tried 16 times. If the error persists, terminate the retry procedure. If an error is detected during the memory/record comparison, the write and write-checking routine should be retried once.

3-75. **ADDRESS ERRORS.** When an address error occurs, the interface will automatically return the heads to cylinder zero. Re-issue the Seek Record command to the failing cylinder and if the error persists, terminate the retry procedure.

3-76. **OVERRUNS.** If an overrun occurs, retry the operation once and if the error persists, terminate the retry procedure.

3-77. TYPICAL PROGRAM.

3-78. Table 3-3 is a typical assembly language program that will transfer data to and from the disc drive under DMA control and check status.

Table 3-3. Typical Assembly Language Program

READ PROGRAM (NON INTERRUPT)			
CW1A	OCT	1 2 0 0 U U	DMA PROGRAM CONTROL WORD, UU IS DATA CHANNEL SELECT CODE
CW2B	OCT	1 A A A A A	DMA STARTING ADDRESS; DATA INTO MEMORY (MAX. ADDR. = 77777B)
CW3A	OCT	-0 B B B B B	DMA WORD COUNT (MAX. COUNT = 06144B, 2's COMPLEMENT i.e., 171634B)
RDCMD	OCT	0 2 0 0 0 0	READ COMMAND WORD
DN	NOP		DRIVE NUMBER (0 THROUGH 3)
	JSB	SEEK	MOVE HEAD TO DESIRED CYLINDER
	CLC	DC	INSURE CONTROL SIGNALS ARE RESET ON
	CLC	CC	DATA AND COMMAND CHANNELS
	LDA	CW1A	GET FIRST DMA CONTROL WORD
	OTA	6	OUTPUT TO DMA CHANNEL
	CLC	2	PREPARE DMA FOR DMA CONTROL WORD 2
	LDA	CW2B	GET DMA CONTROL WORD 2
	OTA	2	OUTPUT TO DMA CHANNEL
	STC	2	PREPARE DMA FOR DMA CONTROL WORD 3
	LDA	CW3A	GET DMA CONTROL WORD 3
	OTA	2	OUTPUT TO DMA CHANNEL
	LDA	RDCMD	GET INTERFACE READ COMMAND WORD
	IOR	DN	
	OTA	CC	OUTPUT TO COMMAND CHANNEL
	STC	DC,C	PREPARE DATA CHANNEL FOR READ OPERATION
	STC	6,C	ACTIVATE DMA
	STC	CC,C	INITIATE READ OPERATION
	SFS	CC	IS READ OPERATION COMPLETE
	JMP	*-1	NO. WAIT.
	JSB	STATS	YES. GO CHECK STATUS
WRITE PROGRAM (NON INTERRUPT)			
CW1A	OCT	1 2 0 0 U U	DMA PROGRAM CONTROL WORD, UU IS DATA CHANNEL SELECT CODE
CW2A	OCT	0 A A A A A	DMA STARTING ADDRESS; DATA OUT OF MEMORY (MAX. ADDR. = 77777B)
CW3A	OCT	-0 B B B B B	DMA WORD COUNT (MAX. COUNT = 06144B, 2's COMPLEMENT i.e., 171634B)
WRCMD	OCT	0 1 0 0 0 0	WRITE COMMAND WORD
DC	EQU	UU	UU IS DATA CHANNEL SELECT CODE
CC	EQU	VV	VV IS COMMAND CHANNEL SELECT CODE
DN	NOP		DRIVE NUMBER (0 THROUGH 3)
	JSB	SEEK	MOVE HEAD TO DESIRED CYLINDER
	CLC	DC	INSURE CONTROL SIGNALS ARE RESET
	CLC	CC	ON DATA AND COMMAND CHANNELS.
	LDA	CW1A	GET FIRST DMA CONTROL WORD
	OTA	6	OUTPUT TO DMA CHANNEL
	CLC	2	PREPARE DMA FOR DMA CONTROL WORD 2
	LDA	CW2A	GET SECOND DMA CONTROL WORD
	OTA	2	OUTPUT TO DMA CHANNEL
	STC	2	PREPARE DMA FOR DMA CONTROL WORD 3
	LDA	CW3A	GET THIRD DMA CONTROL WORD
	OTA	2	OUTPUT TO DMA CHANNEL
	STC	DC	
	STF	DC	ENABLE DMA TO DATA CHANNEL DATA TRANSFER
	STC	6,C	ACTIVATE DMA
	LDA	WRCMD	GET INTERFACE WRITE COMMAND WORD
	IOR	DN	

Table 3-3. Typical Assembly Language Program (Continued)

WRITE PROGRAM (NON INTERRUPT) (Continued)			
OTA	CC		OUTPUT COMMAND WORD TO COMMAND CHANNEL
STC	CC,C		INITIATE WRITE COMMAND
SFS	CC		IS WRITE OPERATION COMPLETE?
JMP	*-1		NO. WAIT
JSB	STATS		YES. GO CHECK STATUS.
SEEK SUBROUTINE (NON INTERRUPT)			
DC	EQU	UU	UU IS DATA CHANNEL SELECT CODE
CC	EQU	VV	VV IS COMMAND CHANNEL SELECT CODE
CYLNO	OCT	0 0 W W W	WWW IS CYLINDER NUMBER
HDSEC	OCT	0 0 X X X X	XXXX IS FORMATTED HEAD AND SECTOR NUMBER
SKCMD	OCT	0 3 0 0 0 0	SEEK COMMAND WORD
DN	NOP		DRIVE NUMBER (0 - 3)
SEEK	NOP		SUBROUTINE ENTRY POINT
CLC	DC		INSURE CONTROL SIGNALS ARE RESET
CLC	CC		ON DATA AND COMMAND CHANNELS
LDA	CYLNO		GET DESIRED CYLINDER ADDRESS
OTA	DC		
STC	DC,C		OUTPUT CYLINDER ADDRESS TO DATA CHANNEL
LDA	SKCMD		GET SEEK COMMAND WORD
IOR	DN		
OTA	CC		OUTPUT SEEK COMMAND TO COMMAND CHANNEL
STC	CC,C		INITIATE SEEK COMMAND
SFS	DC		FIRST ADDRESS WORD ACCEPTED?
JMP	*-1		NO. WAIT.
LDA	HDSEC		YES. GET HEAD/SECTOR ADDRESS WORD.
OTA	DC		
STC	DC,C		OUTPUT HEAD/SECTOR ADDRESS TO DATA CHANNEL
SFS	CC		SEEK OPERATION COMPLETE?
JMP	*-1		NO. WAIT
JSB	STATS		YES. GO CHECK STATUS
JMP	SEEK, I		RETURN TO CALLING PROGRAM
STATUS CHECK SUBROUTINE			
DC	EQU	UU	UU IS DATA CHANNEL SELECT CODE
CC	EQU	VV	VV IS COMMAND CHANNEL SELECT CODE
STCMD	OCT	0 0 0 0 0 0	STATUS CHECK COMMAND WORD
DN	NOP		DRIVE NUMBER (0 THROUGH 3)
STATS	NOP		ENTRY POINT
CLC	DC		INSURE CONTROL SIGNALS ARE
CLC	CC		RESET ON COMMAND AND DATA CHANNELS
LDA	STCMD		GET STATUS CHECK COMMAND WORD
IOR	DN		
OTA	CC		OUTPUT TO COMMAND CHANNEL
STC	CC,C		INITIATE STATUS CHECK COMMAND
SFS	DC		IS STATUS WORD READY?
JMP	*-1		NO. WAIT
LIA	DC		LOAD STATUS WORD
SLA			IS ANY ERROR BIT SET?
JMP	ERROR		YES. GO TO ERROR ROUTINE.
JMP	STATS, I		NO. RETURN TO CALLING PROGRAM

SECTION IV

THEORY OF OPERATION

4-1. INTRODUCTION.

4-2. This section contains theory of operation and operational flow diagrams for the 13210A Disc Drive Interface Kit. Block diagrams for the two interface PCA's are shown in figures 4-3 and 4-4. Operation is shown in figures 4-5 through 4-7.

4-3. FUNCTIONAL DESCRIPTION.

4-4. POWER ON.

4-5. When power is initially applied to the computer, the POPIO and CRS signals are received simultaneously from the computer's I/O control PCA. The signals establish initial operating conditions for the interface PCA's. The POPIO signal sets both the command channel and data channel Flag FF's. The CRS signal clears the command channel Control FF and the data channel Encode FF, clears the Attention register, and transfers cylinder address 000 to the disc drive.

4-6. Once the computer sends the PON signal to the disc interface 1 PCA, the disc interface 1 PCA issues a Control signal to the disc drive. The Control signal indicates to the disc drive that the computer dc power supplies have stabilized.

4-7. COMMAND EXECUTION.

4-8. For the disc drive(s) to perform any operation commanded by the computer the interface must execute numerous internal operations. These internal operations, and the associated decision-making, are synchronously performed by a state decoder that is activated by a read-only memory (ROM) and a state register. Synchronous operation is provided by a 2.5-MHz Control Clock signal that is generated by a 10-MHz crystal oscillator and divider. See figure 4-3.

4-9. Each four-bit command word is applied to the ROM as part of an eight-bit address. Each addressed ROM memory location contains a unique four-bit word that is synchronously loaded into the state register. The state register output is decoded by the state decoder, whose outputs serve as internal "instructions" for the interface. By monitoring the ROM output, disc drive status, and other interface signals, a qualifier encoder alters the ROM address, and the state decoder issues sequential instructions for the interface at the appropriate times.

4-10. In this manner, the interface controls the execution of computer commands that require multiple steps.

For example, when a Seek Record command is received, the interface will control the transfer timing of the two-word record address between the computer and disc drive. The interface will then wait, if necessary, for the disc drive to move the heads over the addressed record, and will only signal the computer for additional commands when the disc drive has completed execution of the command. Commands requiring less complex internal operations (e.g. Read) are decoded directly by a command decoder and re-issued as a single-line command to the disc drive at the appropriate time. Although re-issuance of such a command is more direct, the ROM-state decoder circuitry described above is still required for the execution of these commands. When a Read command is received, for example, the ROM-state decoder circuits will control the actual reading of data from the disc drive and execute the transfer of read data to the computer.

4-11. DATA TRANSFER EXECUTION.

4-12. The execution of commands requiring data transfer also requires the interface to perform numerous internal operations. When data supplied by the computer is to be written by the disc drive, the interface control of the write operation includes: transferring record addresses, drive addresses, etc.; checking for correct address response by the disc drive; ensuring proper sector format (which includes an address field and a data field); adding clock information to the data being written; performing parallel-to-serial conversion of data words; generating check characters; and continuously monitoring the write operation until completed. When data is to be transferred to the computer, the interface control of the read operation includes: transferring record addresses, drive addresses, etc.; checking for correct address response by the disc drive; separating clock information from the data; performing serial-to-parallel conversion of data words; checking for data errors; and continuously monitoring the read operation until completed. See figure 4-4.

4-13. WRITE OPERATIONS. The format in which address fields and data fields are written on the disc is controlled by a sector formatter; clock information is added to the data by a write formatter. A detected sector pulse activates the formatter. By counting bits and 16-bit words and enabling data to be written at prescribed times, each sector is written in the format shown in figure 4-1. (The 2.5-MHz clock signal is generated by the 10-MHz crystal oscillator and divider mentioned above.)

4-14. Data words and address words are transferred from the computer through an output buffer register. Bits of the buffer register output that contain the address information

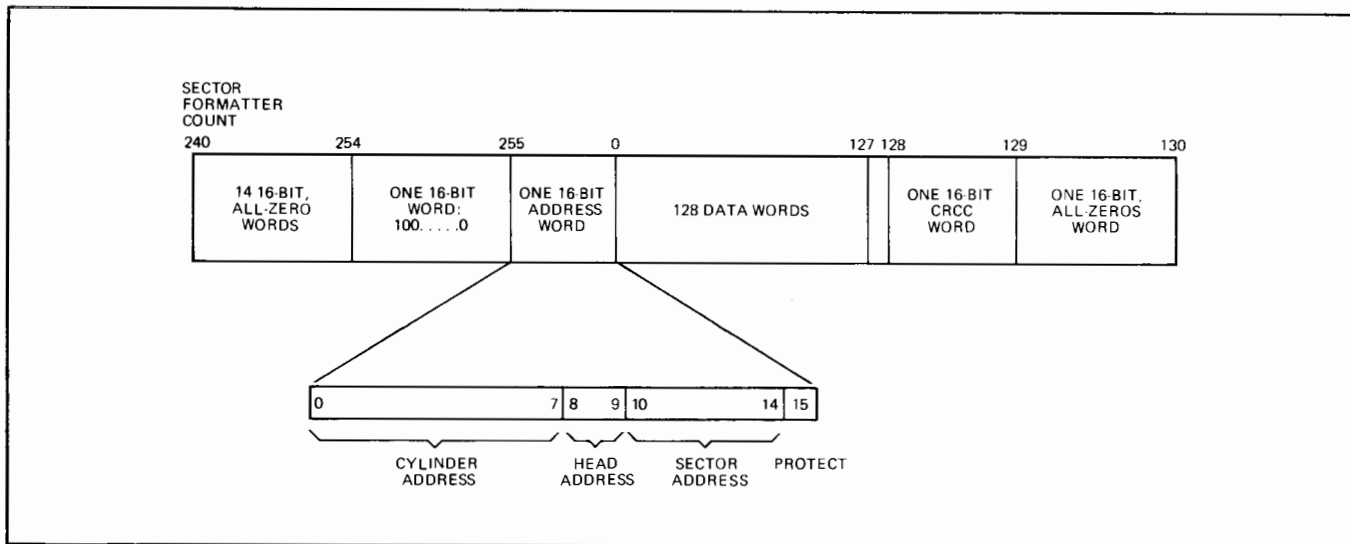

7012-8

Figure 4-1. Sector Write Format

in an address word (all 16 bits are not used) are parallel-connected to a record address register (RAR). The outputs of both the buffer register and the RAR are applied to a multiplexer that transfers only one of the outputs at a time to a parallel-to-serial/serial-to-parallel converter. The sector formatter, described above, determines when the address field is to be written and strobes the RAR contents to the converter. When the sector formatter determines that the data field is to be written, the contents of the output buffer register are strobed to the converter. The serial output of the converter is routed through the sector formatter and write formatter described above.

4-15. Serial data from the output of the sector formatter is parallel-fed to a cyclic redundancy check character (CRCC) generator. The bit pattern of the 16-bit CRCC word is a function of the data field bit pattern and the Boolean equation of the CRCC generator. The CRCC word, when read at the end of a subsequent read operation, aids in determining if any read data errors occurred.

4-16. READ OPERATIONS. Serial data read from the disc drive is applied to a phase-lock loop in the read data decoder. Because variations in the rotational speed of disc drives causes the frequency of the clock information contained in the read data to vary, the phase-lock loop includes a voltage-controlled oscillator that provides the frequency flexibility required to compensate for these variations. The phase-lock loop produces a nominal output of 2.5 MHz, the precise frequency of the data when written. The combination of the phase-lock loop output and the read data input is used to separate the data from the clock information. Separated data is routed to the serial-to-parallel converter and to the CRCC generator. At the appropriate time (every 16th bit), the sector formatter loads the contents of the converter into the read buffer register. The read buffer register contents are strobed into the input buffer register for subsequent transfer to the computer. The CRCC generator monitors the read data, compares it with

the CRCC word that is read at the end of each data field and sets the appropriate bit in the interface status register when a data error is detected.

4-17. DETAILED CIRCUIT DESCRIPTION.

4-18. COMMAND EXECUTION.

4-19. The four most significant bits of the words are loaded into the command output register U77 by an OTA/B instruction addressed to the command channel. The register contents are decoded by command decoder U83 and are routed to the read-only memory (ROM) U93 as part of an eight-bit address. The command decoder converts the four bits of command from the computer to single-line commands for transfer to the disc drive. The four-bit ROM outputs are translated by the state decoder U21, which issues additional "internal" instructions that are required to execute the computer command.

4-20. The qualifier encoder U103 provides one bit of the eight-bit ROM address. The level of the qualifier bit is determined by comparison of the current ROM state (in the state register) with various status signals from other interface circuits and the disc drive. As a result, the sequence of state decoder outputs is determined by the command issued and the current status of the interface and disc drive.

4-21. DATA TRANSFER OPERATIONS.

4-22. Record addresses and data from the computer are transferred through the output buffer register (U57 and U87). The register contents are parallel-connected to the record address register (RAR) (U56, U66, and U67) and the multiplexer (U47, U46, U97, and U96). The multiplexer strobes the contents of the RAR or the output buffer register into the parallel-to-serial/serial-to-parallel converter (U25 and U105) at the appropriate time.

4-23. During write operations, the contents of the RAR are loaded when the address field of the sector is being written; the contents of the output buffer register are loaded when the data field is being written. Control of the format in which the sectors are written is maintained by the sector formatter described in paragraphs 4-26 through 4-28.

4-24. During read operations, serial data is stacked by the converter and, at the appropriate time, 16-bit words are loaded into the read buffer register (U26 and U106). The contents of the read buffer register are also present in the input buffer register (U27, U28, U107, and U108). Data is transferred from the input buffer register to the computer by an LIA/B or MIA/B instruction addressed to the data channel.

4-25. WRITE OPERATIONS.

4-26. Write data is presented serially to the disc drive by the write formatter (U41A and U41B). The write formatter combines the 2.5-MHz clock signal and the data to be written in the format shown in figure 4-2. (During refine sector operations, line driver U81 is inhibited so that no data is actually written; in all other respects the operation is identical to writing.) The format in which sector address fields and data fields are written is controlled by the sector formatter which controls the application of data to the write formatter. The sector formatter establishes the format by passing data to the write formatter only at precise points in bit- and word-count that is initiated at the beginning of each sector.

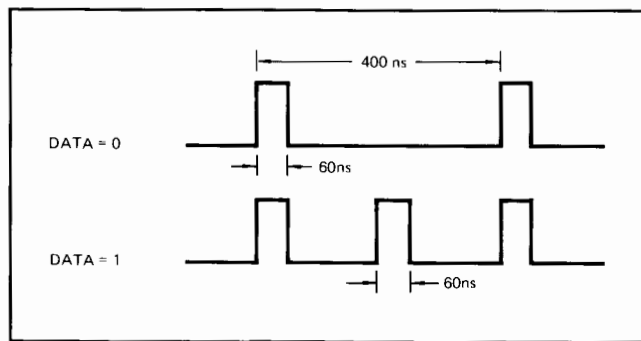

7012-12

Figure 4-2. Data Bit Cell

4-27. When the addressed sector comes into position under the disc drive heads, the bit and word counter in the sector formatter is enabled by "and" gate U33D(C6). Subsequent Data Clock pulses from "and" gate U82B(B4) clock the bit counter (U43). Every 16 bits the bit counter clocks the word counter (U63 and U113). At appropriate word counts, the sector formatter enables "and" gate U52B which passes data to the write formatter.

4-28. READ OPERATIONS.

4-29. Serial data from the disc drive is routed to the Sync Phase FF U11A in the phase-lock loop and to the One's Catcher FF U112B. The serial data toggles the Sync Phase FF to provide one input to the voltage-controlled oscillator (VCO)(U101). The VCO output signal toggles the VCO Phase FF (U111B) to provide a second input to the VCO. The VCO phase-compares the two inputs and adjusts its output frequency until synchronized with the read data frequency. The synchronized output is routed through "exclusive-or" gate U23C to clock the Sync One Detector FF (U102B) and Data Buffer FF (U112A), which, along with the Ones Catcher FF, separate the data from the clock information. The serial output of the Data Buffer FF is routed to the serial-to-parallel converter for stacking into 16-bit words.

4-30. The word counter in the sector formatter is preset to count 240 when the data transfer operation commences (i.e. $\overline{\text{Control}}$ goes low). Once the read gate (U71D) is enabled, Data Clock pulses clock the bit counter in the sector formatter, which, in turn, clocks the word counter. When the word counter reaches count 246, the Lock-up Delay FF (U102A) is set. The Lock-up Delay FF enables the Sync One Detector FF and also presets the bit counter to count 15 and the word counter to count 253. As a result, the very next data pulse, which will be the "1" bit in the sector sync word, sets the Sync One Detector FF and thus enables the Data Buffer FF. (The word counter is clocked to count 254 so that address and data words can be counted precisely.) Subsequent data pulses toggle the Data Buffer FF which provides a serial data output in the conventional non-return-to-zero (NRZ) format as shown in figure 4-8.

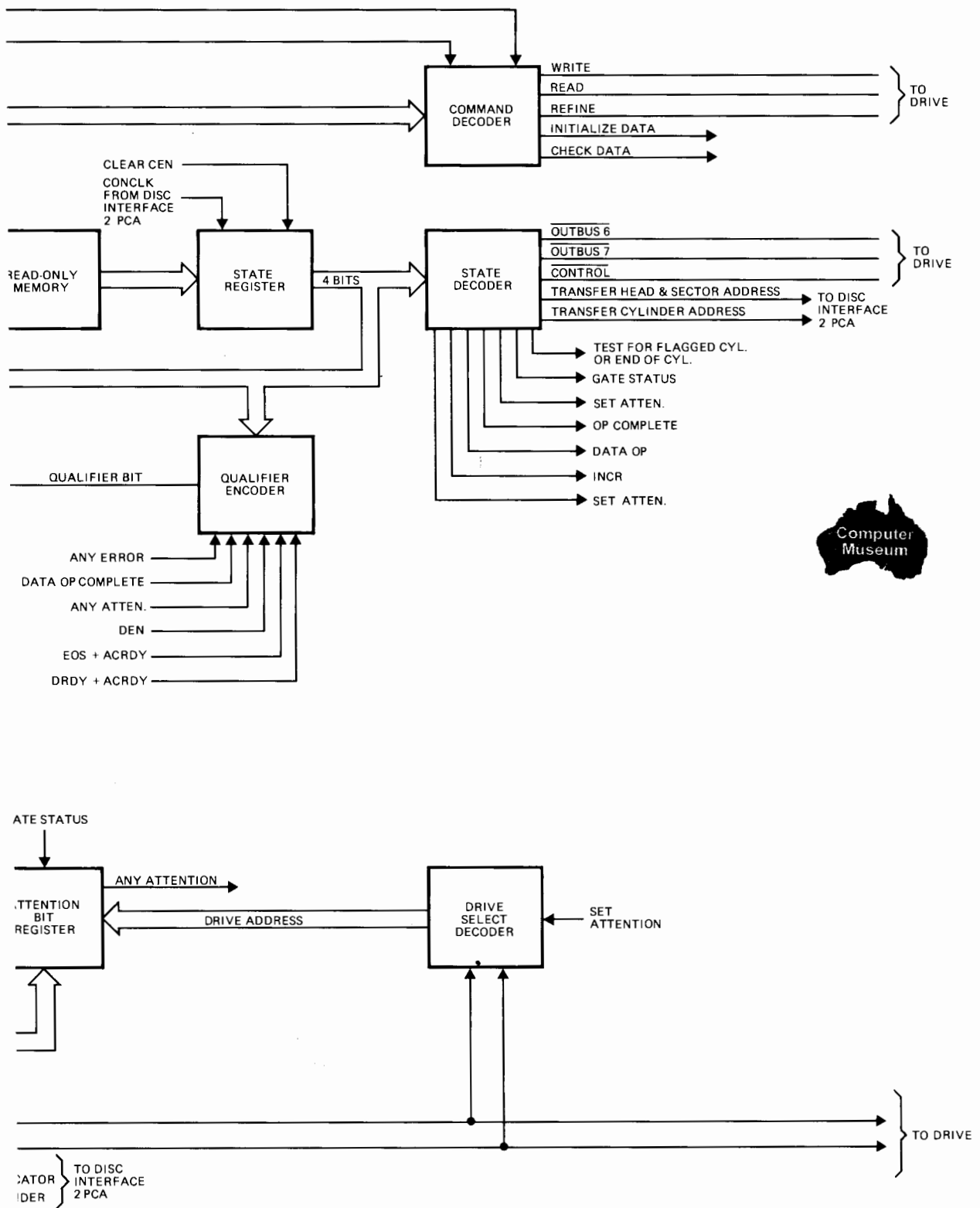
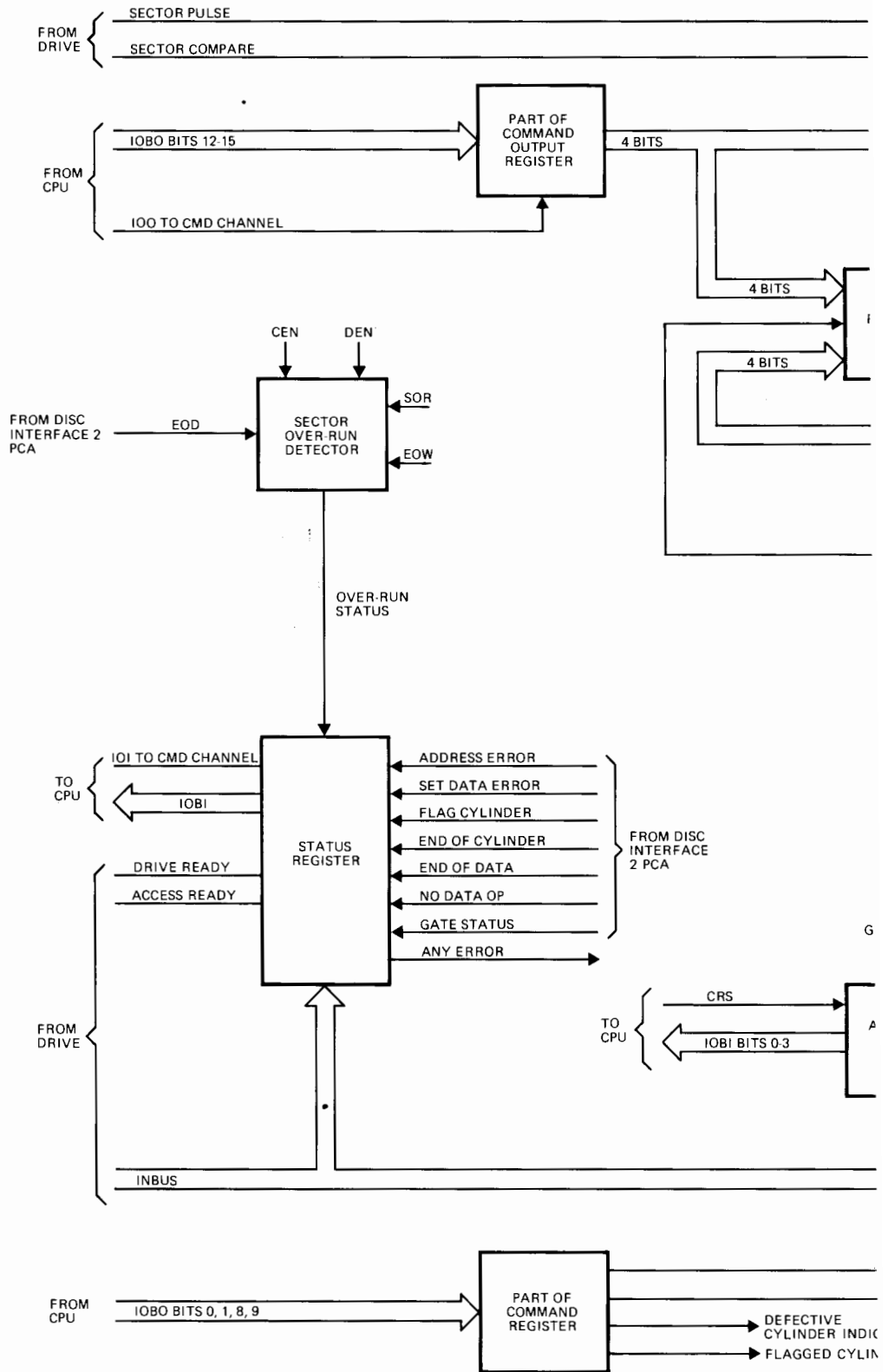

Figure 4-3. Disc Interface 1 PCA Block Diagram



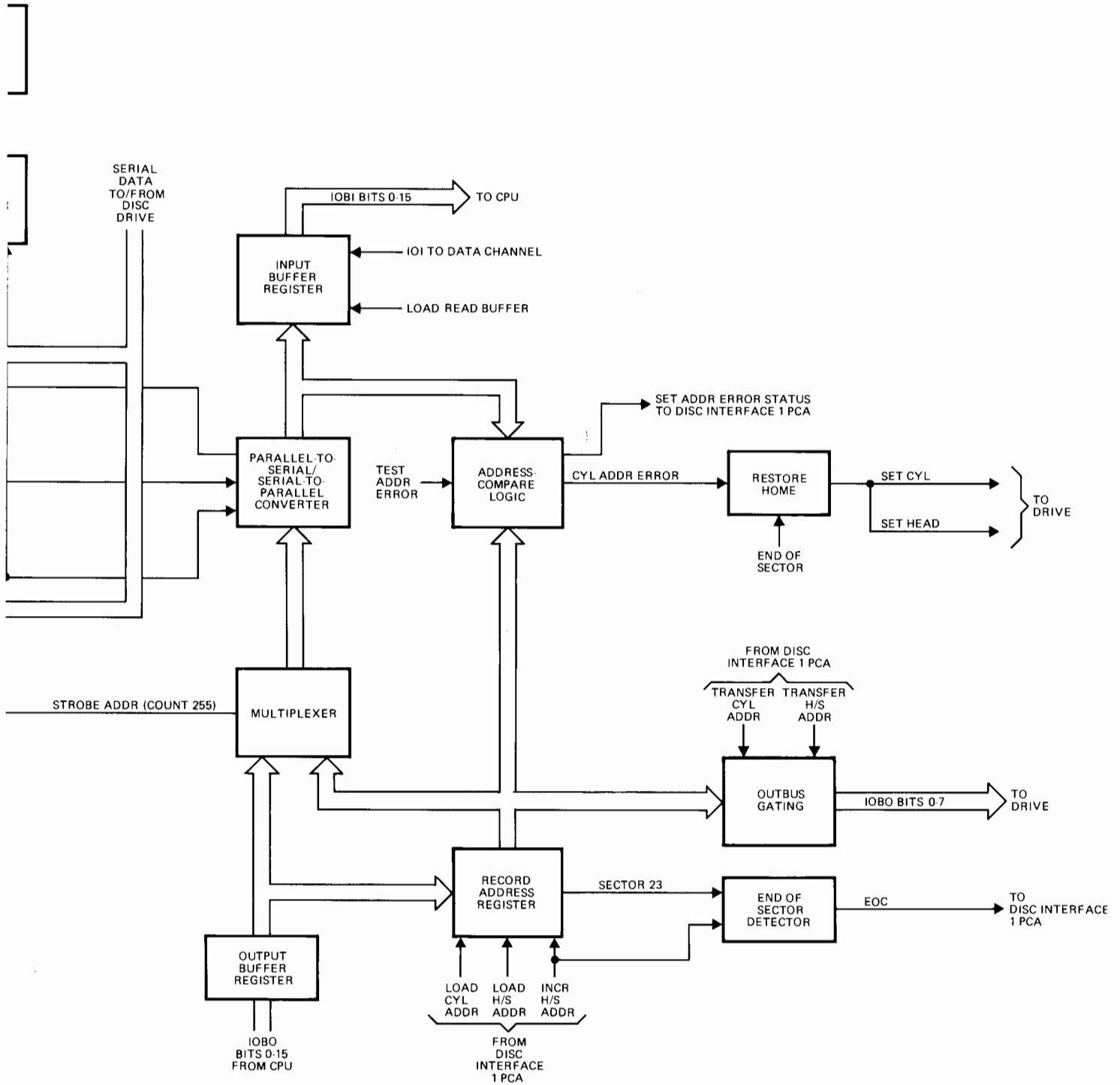
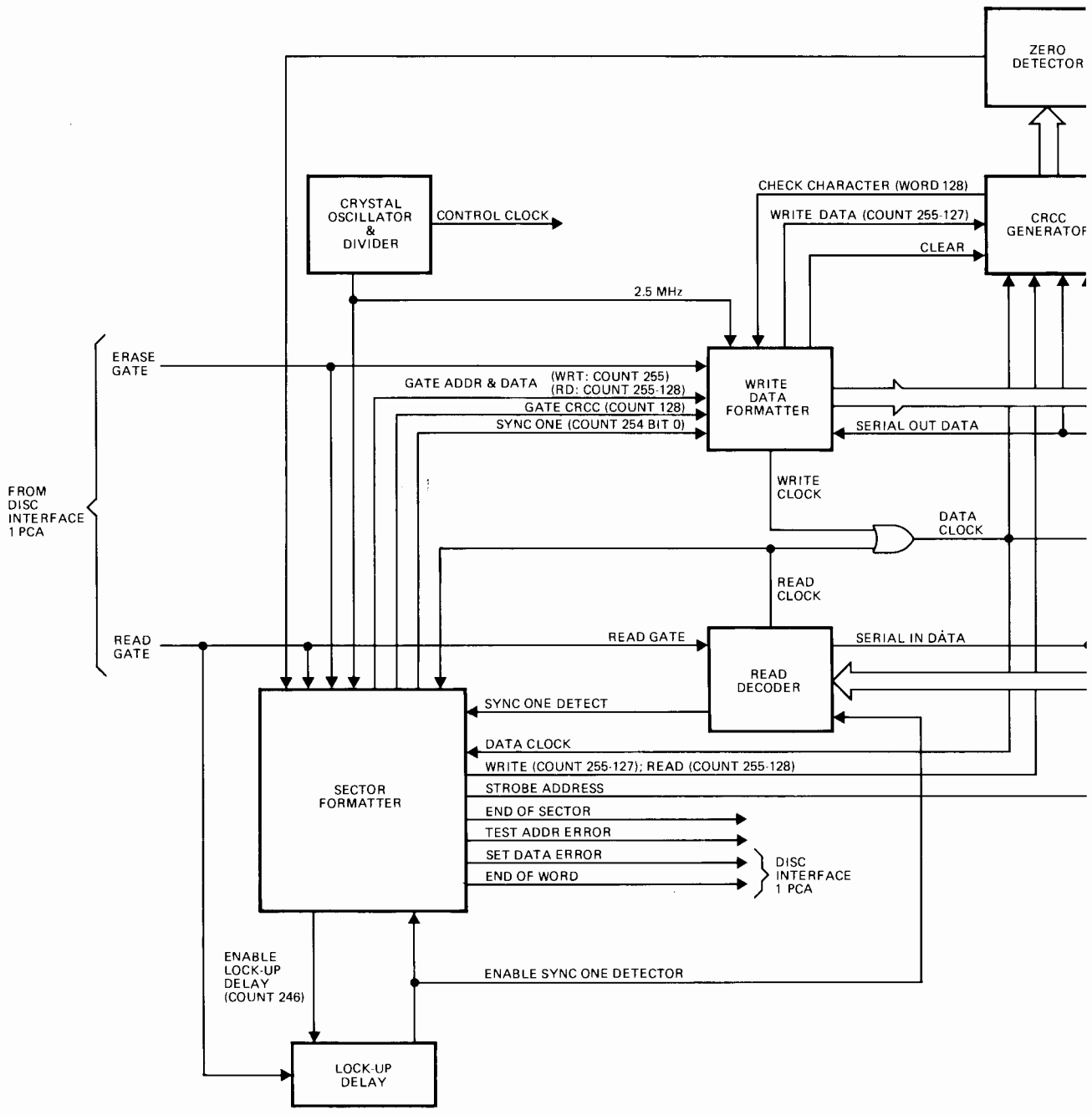

Figure 4-4. Disc Interface 2 PCA Block Diagram



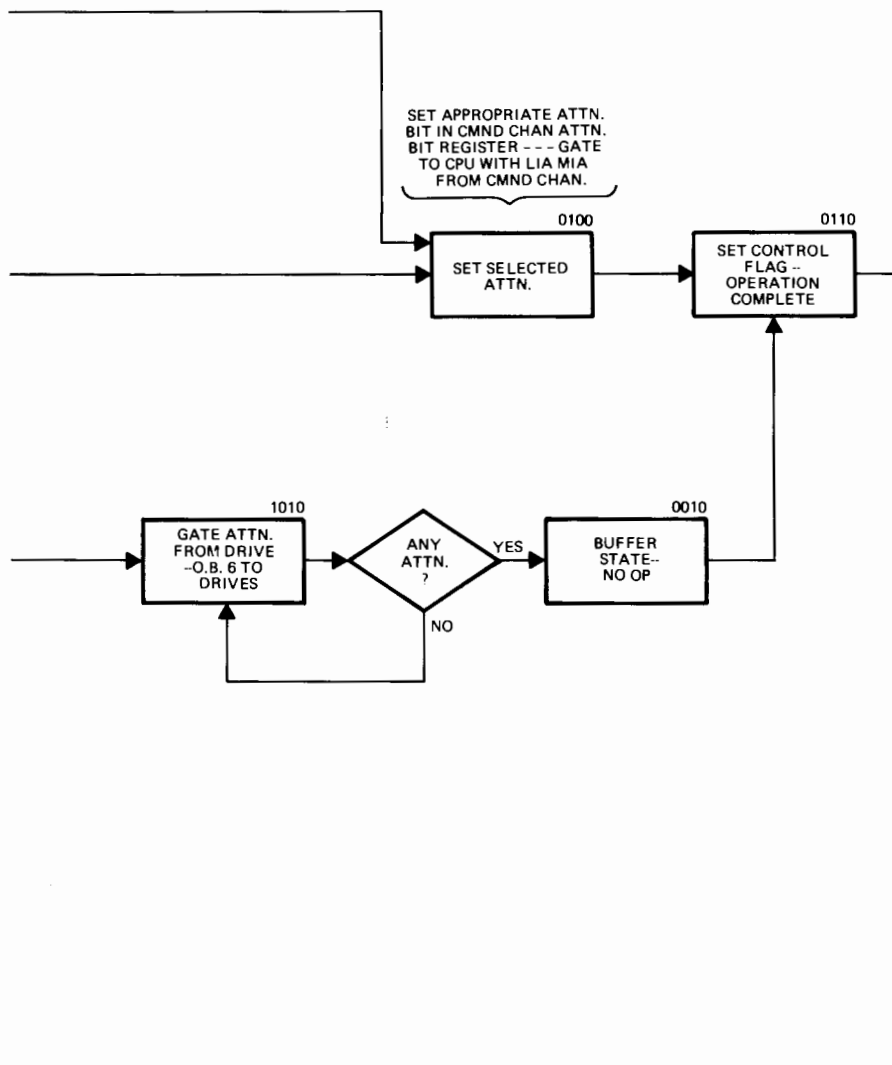
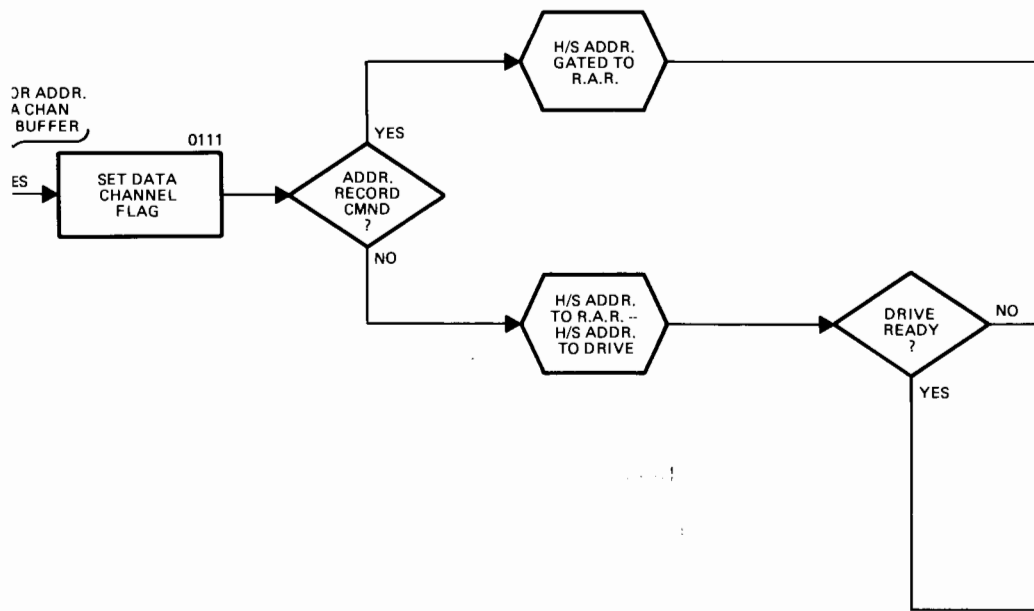
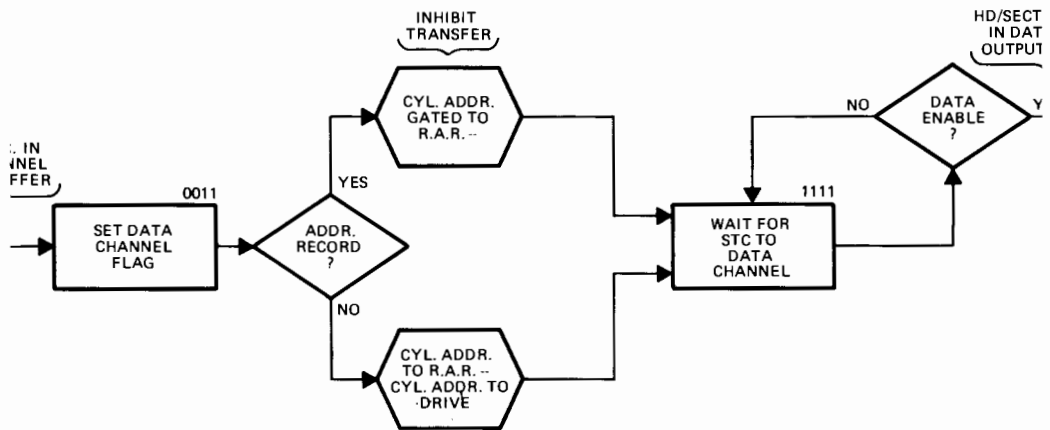
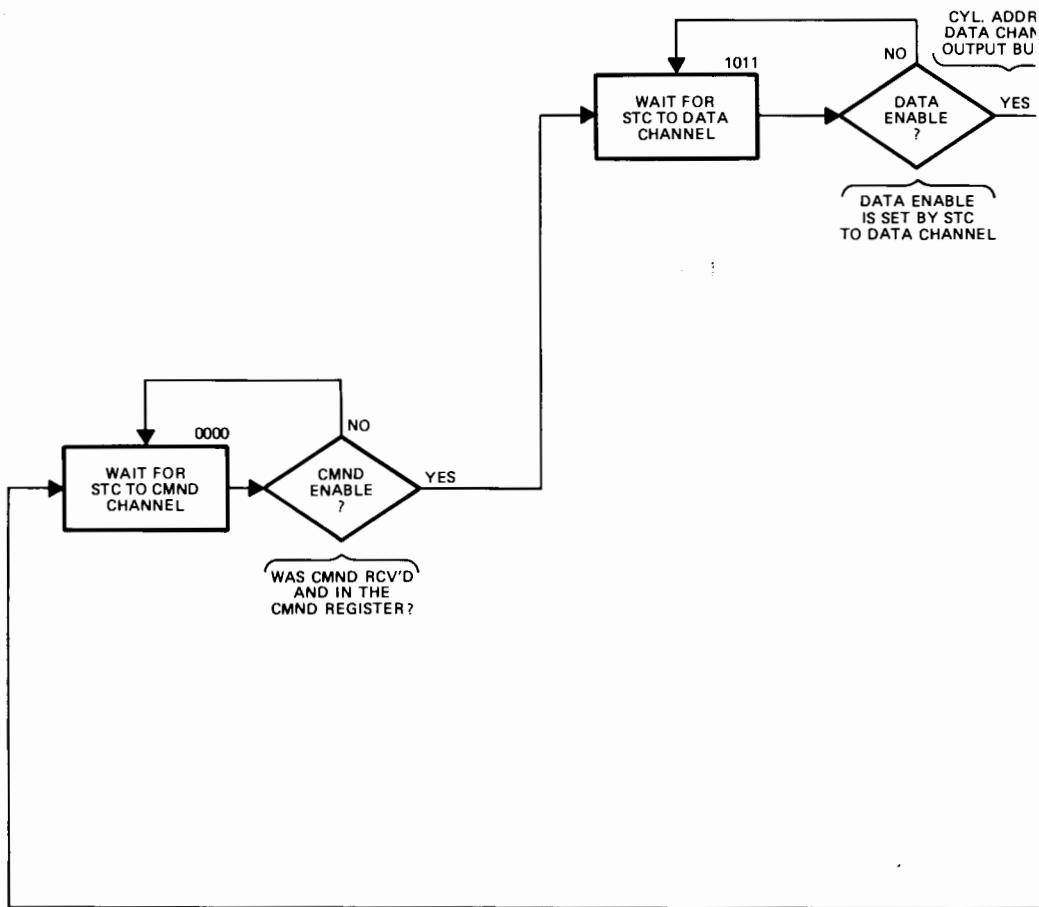

Figure 4-5. Seek Record and Address Record Operations Flow Diagram







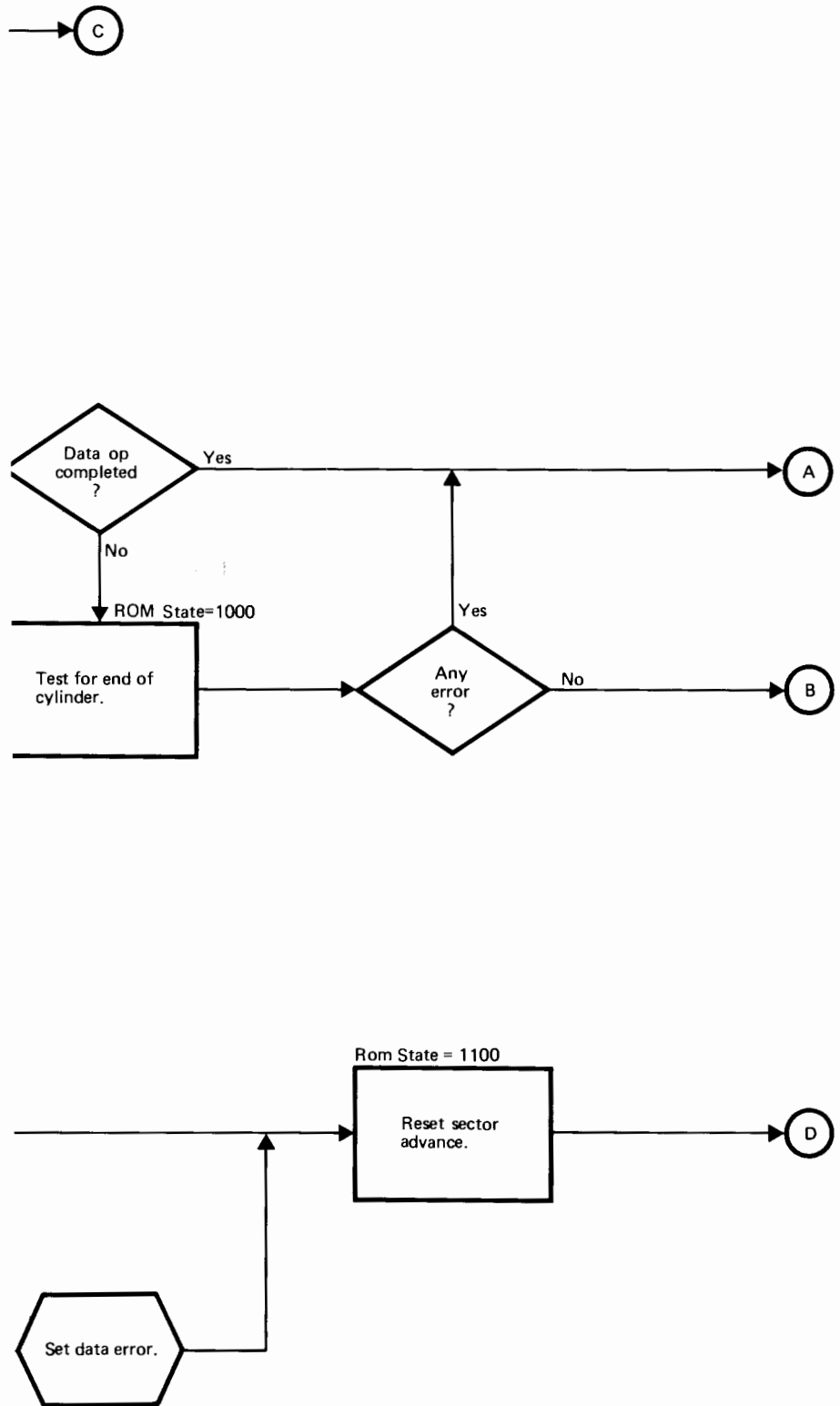
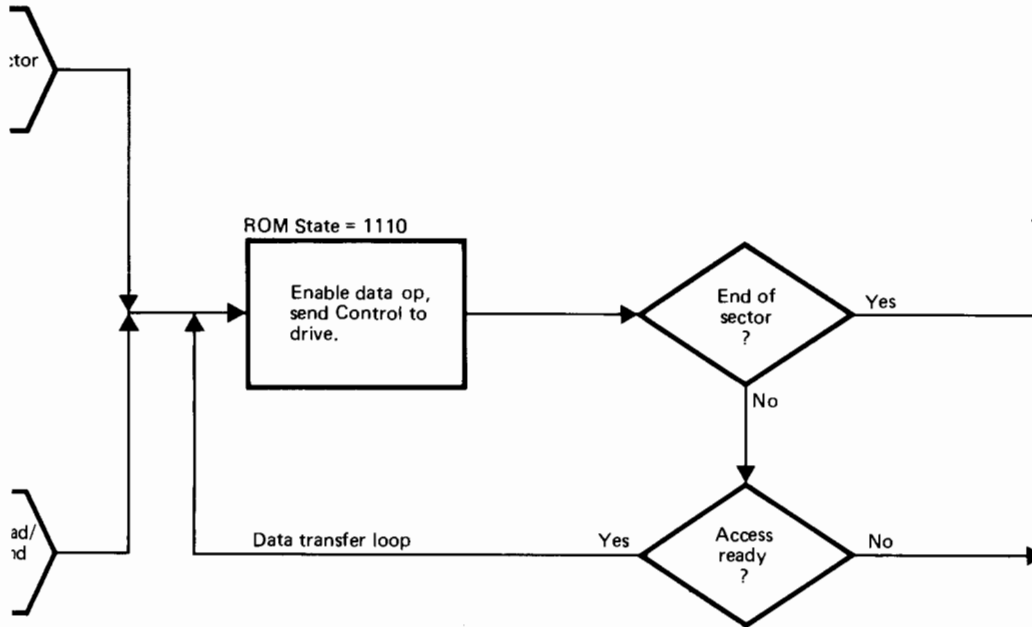
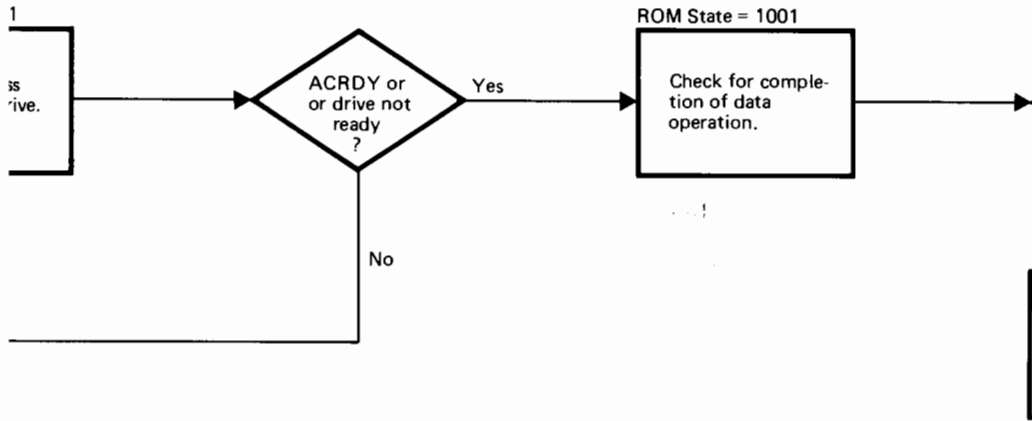
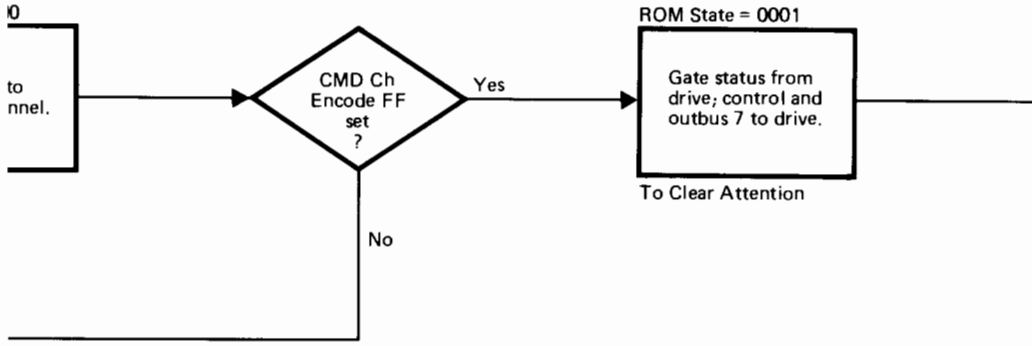
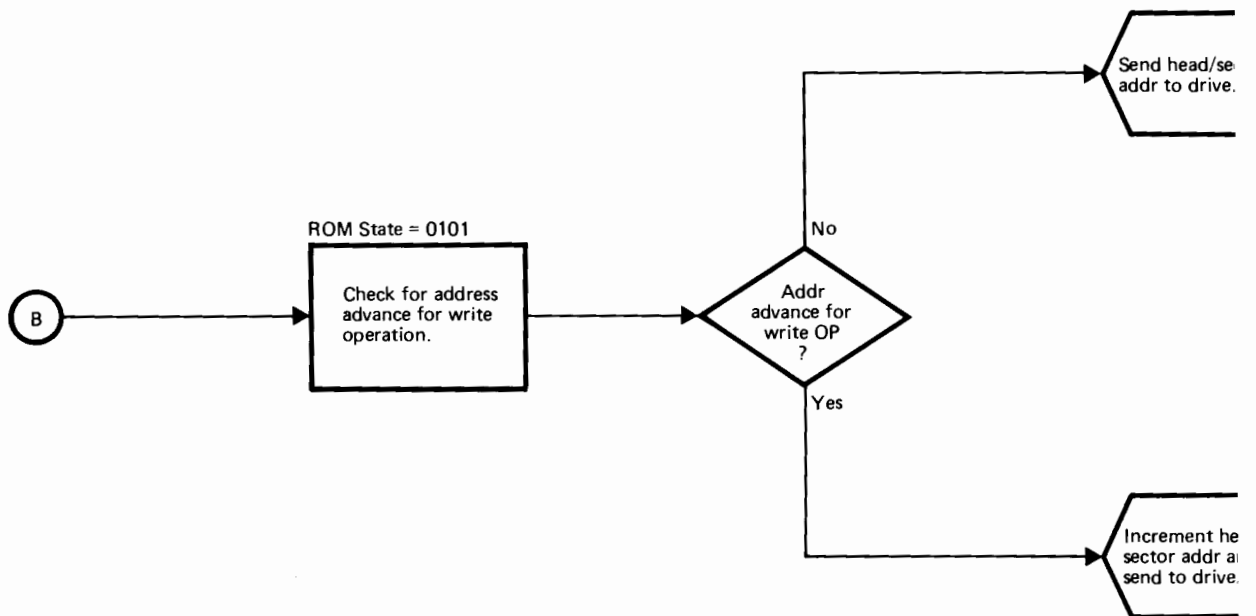
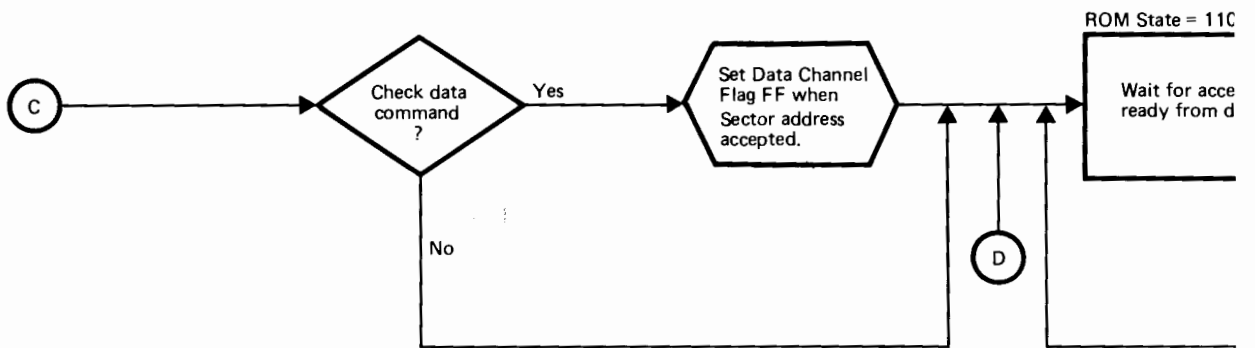
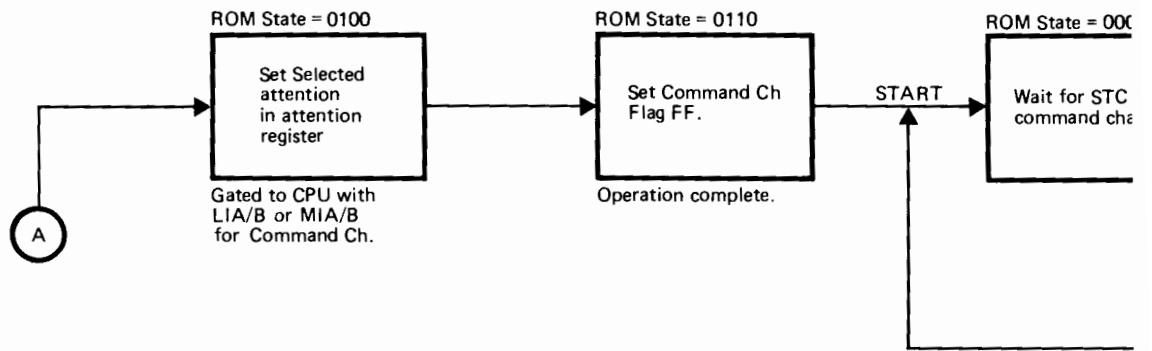

Figure 4-6. Write, Read, Check Data, and Initialize Data Operations Flow Diagram





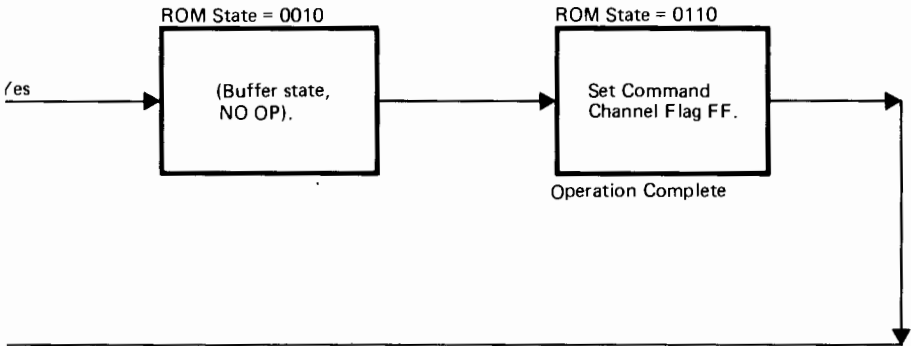
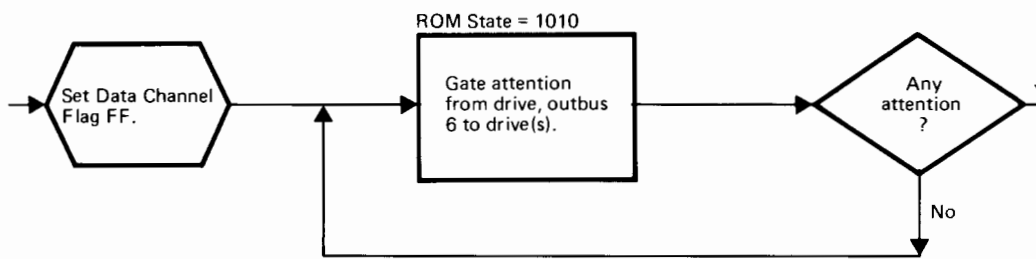
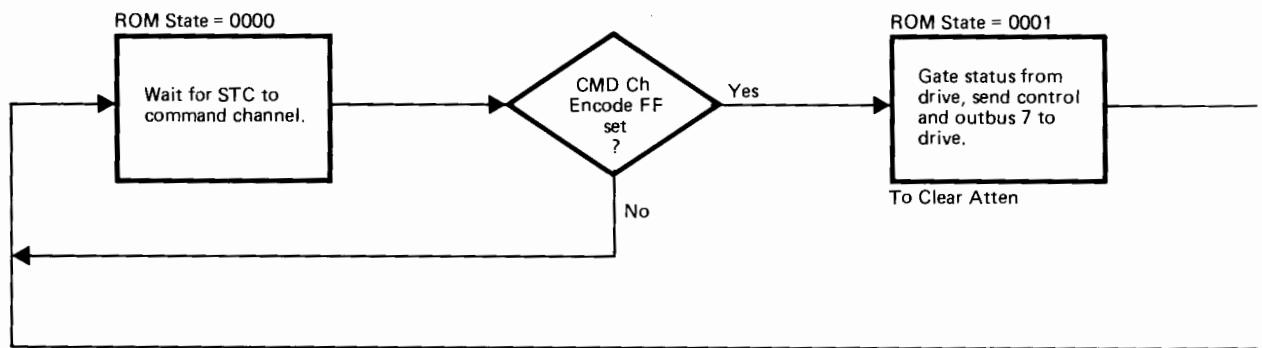
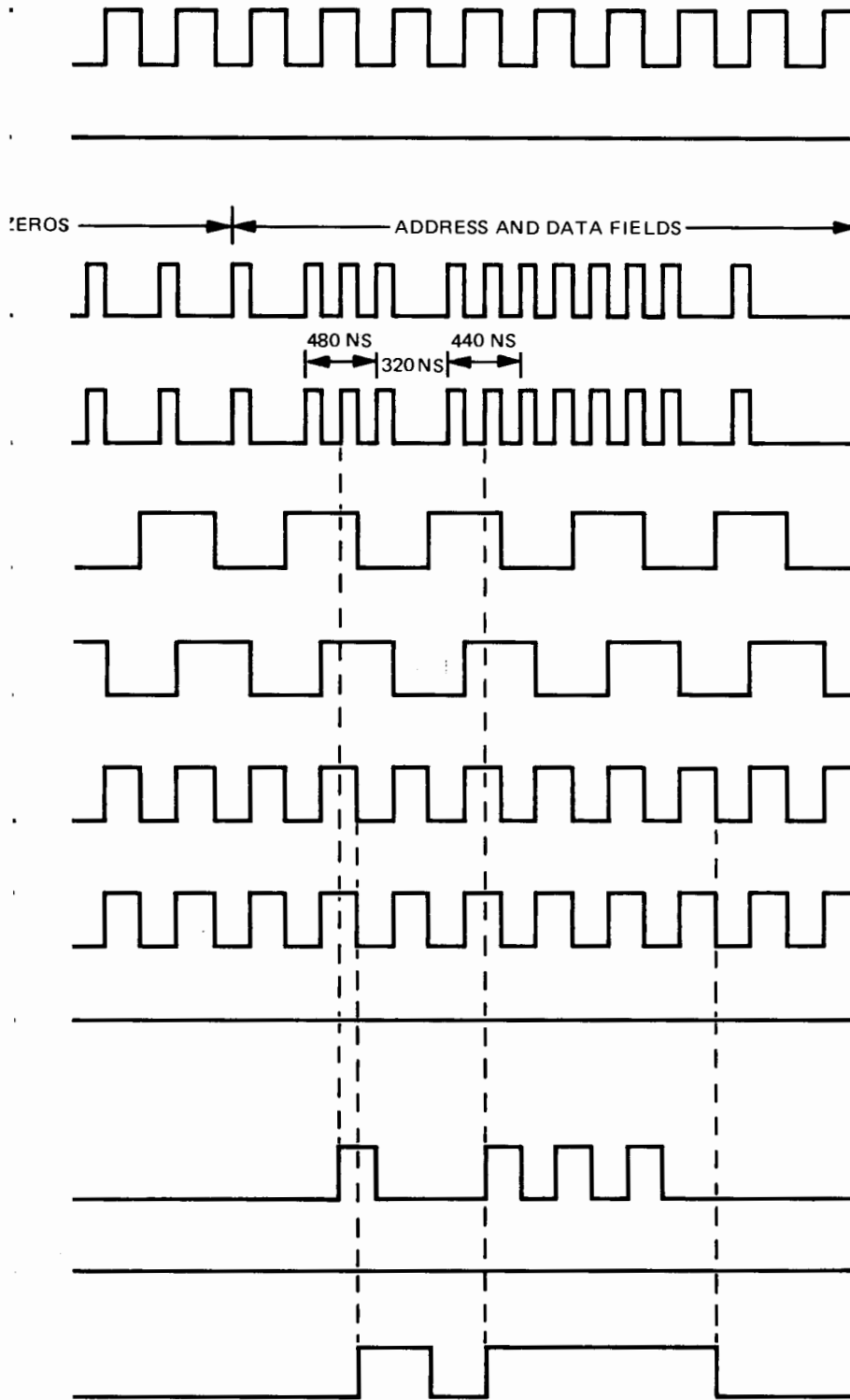

Figure 4-7. Status Operation Flow Diagram







NOTES:

1. ALL SIGNAL LOCATIONS ON DISC INTERFACE 2 PCA (13210-60000).
2. ONE'S CATCHER FF MAY BE SET ANYTIME AFTER READ GATE ENABLED BUT NO "1" BITS ARE PASSED UNTIL AFTER LOCK-UP DELAY FF IS SET.

Figure 4-8. Read Data Separation Timing Diagram

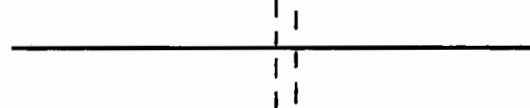
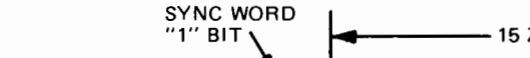
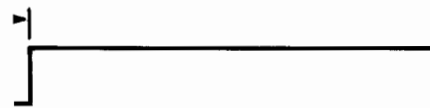

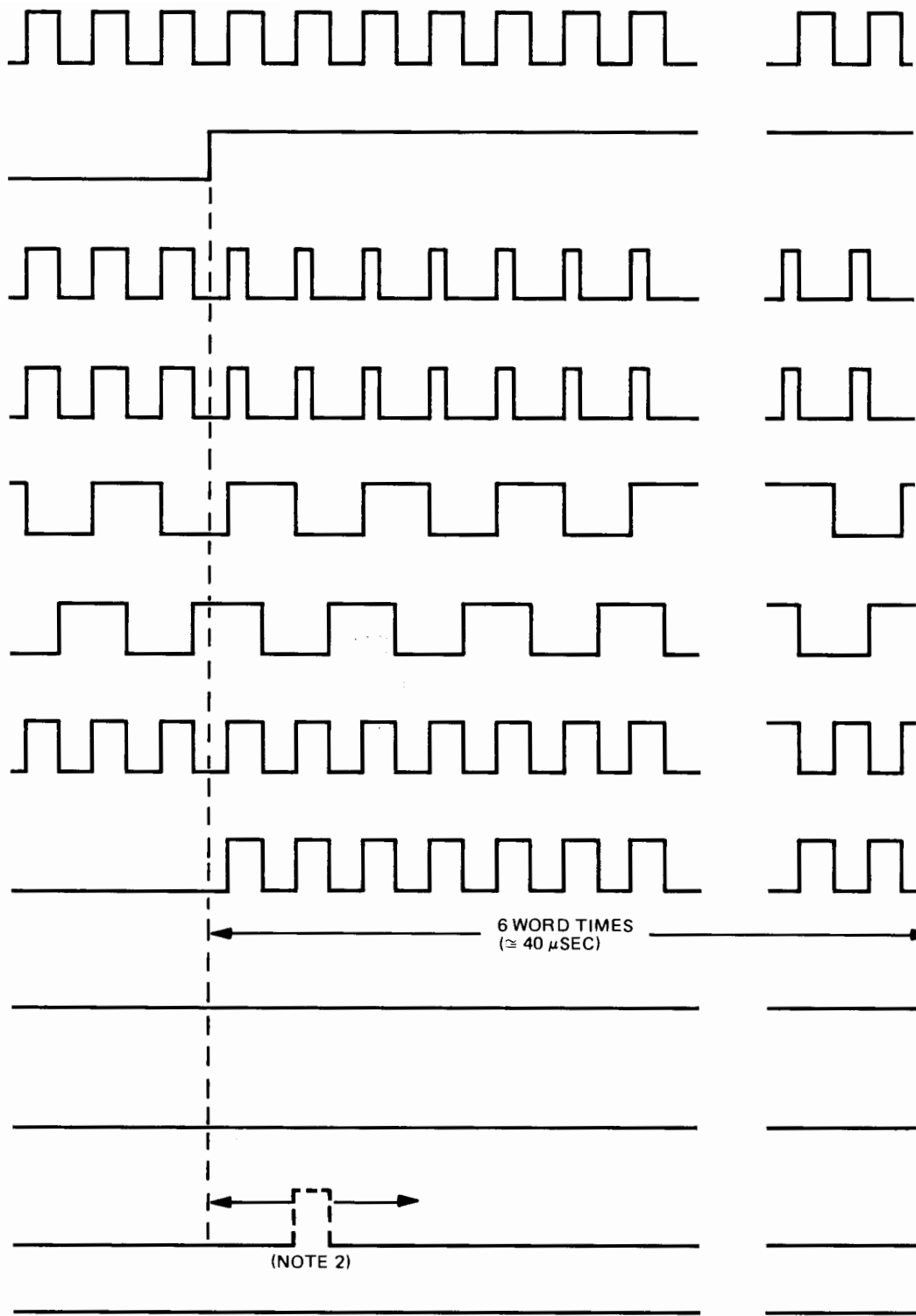

2.5 MHZ FROM
CRYSTAL OSCILLATOR
(U11 PIN 9)



READ GATE:
CONTROL •READ
(U71D PIN 11)



READ DATA
(U91 PIN 4)



READ DATA •
2.5 MHZ
(U92D PIN 11)



SYNC PHASE FF
(U111A PIN 9)



VCO PHASE FF
(U111B PIN 12)



DATA WINDOW:
SYNC PHASE FF =
VCO PHASE FF
(U61C PIN 6)



DATA CLOCK:
READ GATE •
VCO OUTPUT
(U82D PIN 11)



LOCK-UP DELAY FF
(U102A PIN 5)



ONE'S CATCHER FF
(U112B PIN 9)



SYNC ONE
DETECTOR FF
(U102B PIN 9)



DATA BUFFER FF
(U112A PIN 5)



SECTION V MAINTENANCE



5-1. INTRODUCTION.

5-2. This section provides maintenance information for the HP 13210A Disc Drive Interface Kit. Included are preventive maintenance and corrective maintenance instructions, mnemonic definitions, parts location views, and schematic diagrams.

5-3. PREVENTIVE MAINTENANCE.

5-4. Detailed preventive maintenance procedures and schedules are provided in the computer documentation. There are no separate preventive maintenance procedures to be performed on the interface kit.

5-5. CALIBRATION.

5-6. The disc interface 2 PCA (13210-60000) contains a voltage-controlled oscillator (VCO) within the phase-lock loop integrated circuit U101 that may require adjustment following replacement of U101, C17, or C18. Adjustment may also be required periodically if data errors occur.

5-7. The VCO can be checked and adjusted, if necessary, as follows:

a. After at least 5 minutes warm-up time, connect TP2 (U111A, pin 2) to ground and connect digital frequency counter to TP1 (U61B, pin 4).

b. Frequency counter should read between 2.495 and 2.505 MHz.

c. If required, adjust C18 to obtain a counter reading between 2.495 and 2.505 MHz.

5-8. TROUBLESHOOTING.

5-9. Troubleshooting the interface kit is accomplished by performing the appropriate diagnostic program procedures and analyzing the error halts that occur as the test is being run. Figures 5-1 through 5-4 contain the schematic and parts location diagrams for the kit. Tables 5-1 and 5-2 list the replaceable parts for the disc interface 1 and disc interface 2 PCA's. Table 5-3 lists the interconnecting cable plug-to-plug connections.

Table 5-1. Mnemonic Definitions

MNEMONIC	DEFINITION	MNEMONIC	DEFINITION
ACRDY	Access Ready	HAD	Head Address
ADDR ERR; AE	Address Error	ID	Initialize Data
CD	Check Data	IINCR	Inhibit Increment
CDC 0	Check Data Character 0	INCR	Increment
CEN	Command (Channel) Enabled	IOO COM REG	IOO (to Command Register)
CMCH CON FF	Command Channel Control FF	IXSFER	Inhibit Transfer
CMCH FLG FF	Command Channel Flag FF	LRB	Load Read Buffer
CONCLK	Control Clock	PM	Parallel Mode
CSEL	Command Channel Selected	RDGT(B)	Read Gate (Buffered)
CYLAD	Cylinder Address	SAD	Sector Address
DATA OP	Data Operation	SADDR	Strobe Address
DCH FLG FF	Data Channel Flag FF	SEC ADV FF	Sector Advance FF
DCLK	Data Clock	SID	Serial-in Data
DEN	Data (Channel) Enabled	SK SET D FLAG	Seek Set Data Flag FF
DR; DRDY	Drive Ready	SOD	Serial-out Data
DSEL	Data Channel Selected	SOR	Sector Overrun
EOC	End of Cylinder	S6 (etc)	State Register, State 6 (etc)
EOD	End of Data	TAE	Test Address Error
EOS	End of Sector	WC	Write Clock
EOW	End of Word	WRT	Write
ERSGT	Erase Gate	XADDR	Transfer Address
FBS	Flagged Bit Status	XCYL; XFER CYL	Transfer Cylinder
FC; FLG CYL	Flagged Cylinder	XFER H/S(B)	Transfer Head/Sector (Buffered)
FLG BFR RST	Flag Buffer FF Reset		

Table 5-2. Disc Interface 1 PCA (13210-60004) Replaceable Parts

REFERENCE DESIGNATION	HP PART NO.	DESCRIPTION	MFR CODE	MFR PART NO.
	13210-60004	DISC INTERFACE 1 PCA	28480	13210-60004
C1 thru 12, 15 thru 18	0150-0093	CAPACITOR, fxd, cer, 0.01 μ F, +80-20%, 100 VDCW	72982	801-K800011
C13	0160-3455	CAPACITOR, fxd, cer, 470 pF, 10%, 1000 VDCW	56289	C067F102F471KS22
C14*	0160-2145	CAPACITOR, fxd, cer disc, 0.005 μ F, 10%, 500 VDCW	91418	TA
Q1, 2, 3	1854-0477	TRANSISTOR	80131	2N2222A
R1, 2, 3, 5, 6, 8, 13	1810-0075	RESISTOR ARRAY, 750 ohms, 5%, 0.15W each	28480	1810-0075
R4, 7	1810-0127	RESISTOR ARRAY, 240/560 ohms, 5%, 0.15W each	28480	1810-0127
R9 thru 12, 19, 20 21, 23	0683-1025	RESISTOR, fxd, comp, 1000 ohms, 5%, 1/4W	01121	CB 1025
R14	1810-0030	RESISTOR ARRAY, 1k, 5%, 0.15W each	28480	1810-0030
R15, 16	0683-7515	RESISTOR, fxd, comp, 750 ohms, 5%, 1/4W	01121	CB 7515
R17, 18, 22	0683-1015	RESISTOR, fxd, comp, 100 ohms, 5%, 1/4W	01121	CB 1015
U11	1820-0626	INTEGRATED CIRCUIT, TTL	07263	U7B931459X
U12, 15, 24, 26, 34, 36, 42, 51, 92, 94, 95, 96	1820-0054	INTEGRATED CIRCUIT, TTL	01295	SN7400N
U13, 33	1820-0069	INTEGRATED CIRCUIT, TTL	01295	SN7420N
U16, 22	1820-0372	INTEGRATED CIRCUIT, TTL	28480	1820-0372
U17	1820-0758	INTEGRATED CIRCUIT	28480	1820-0758
U21	1820-0495	INTEGRATED CIRCUIT, TTL	01295	SN74154N
U23, 32, 52, 84	1820-0068	INTEGRATED CIRCUIT, TTL	12040	SN7410N
U25, 43, 72, 74, 76, 86	1820-0174	INTEGRATED CIRCUIT, TTL	01295	SN7404N
U27, 28, 57, 97, 98	1820-0758	INTEGRATED CIRCUIT	28480	1820-0758
U35, 63, 75, 104	1820-0141	INTEGRATED CIRCUIT, TTL	04713	MC3001P
U44, 62, 85	1820-0239	INTEGRATED CIRCUIT, TTL	28480	1820-0239
U45	1820-0250	INTEGRATED CIRCUIT, TTL	28480	1820-0250
U46, 56, 102, 105, 106	1820-0437	INTEGRATED CIRCUIT, TTL	04713	MC4015P
U53	1820-0075	INTEGRATED CIRCUIT, TTL	01295	SN7473N
U54	1820-0727	INTEGRATED CIRCUIT, TTL	07263	U7B932159X
U55, 65	1820-0233	INTEGRATED CIRCUIT, TTL	01295	SN74193N
U61, 64	1820-0077	INTEGRATED CIRCUIT, TTL	01295	SN7474N
U66, 101	1820-0577	INTEGRATED CIRCUIT, TTL	01295	SN7416N
U71	1820-0537	INTEGRATED CIRCUIT, TTL	28480	1820-0537
U73, 82	1820-0205	INTEGRATED CIRCUIT, TTL	28480	1820-0205
U77	1820-0726	INTEGRATED CIRCUIT, TTL	01295	SN74199
U81	1820-0621	INTEGRATED CIRCUIT, TTL	01295	SN7438N
U83	1820-0111	INTEGRATED CIRCUIT, TTL	07263	U6B930159X
U93	1816-0005	INTEGRATED CIRCUIT	28480	1816-0005
U103	1820-0615	INTEGRATED CIRCUIT, TTL	04713	FAIR 9312
U107	1820-0238	INTEGRATED CIRCUIT, DTL	04713	MC 1810P
*C14 (below series 1232)	0160-3457	CAPACITOR, fxd, cer disc, 0.002 μ F, 10%, 500 VDCW	56289	C067F501F681KS22-CDH

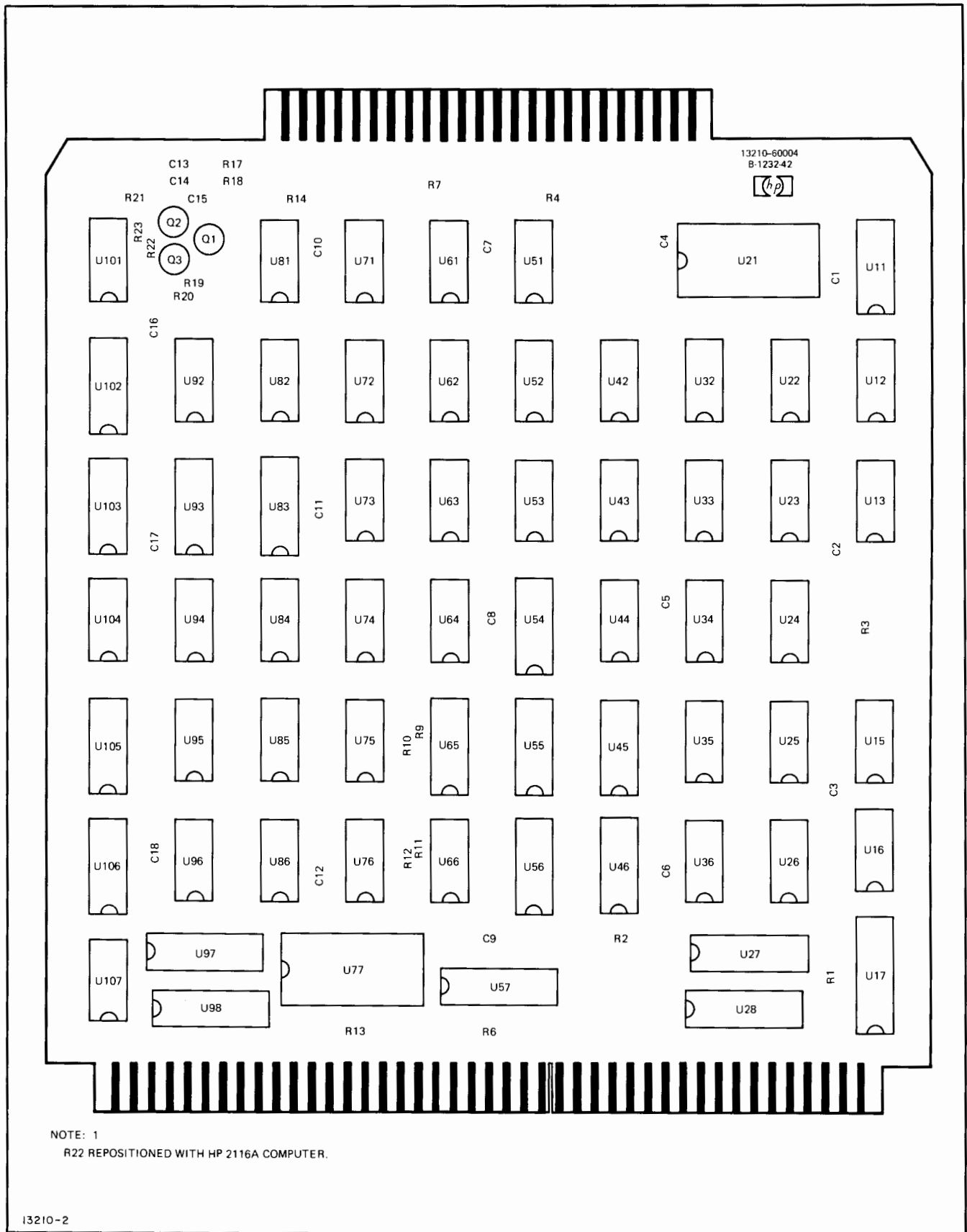

13210-2

Figure 5-1. Disc Interface 1 PCA Parts Location Diagram

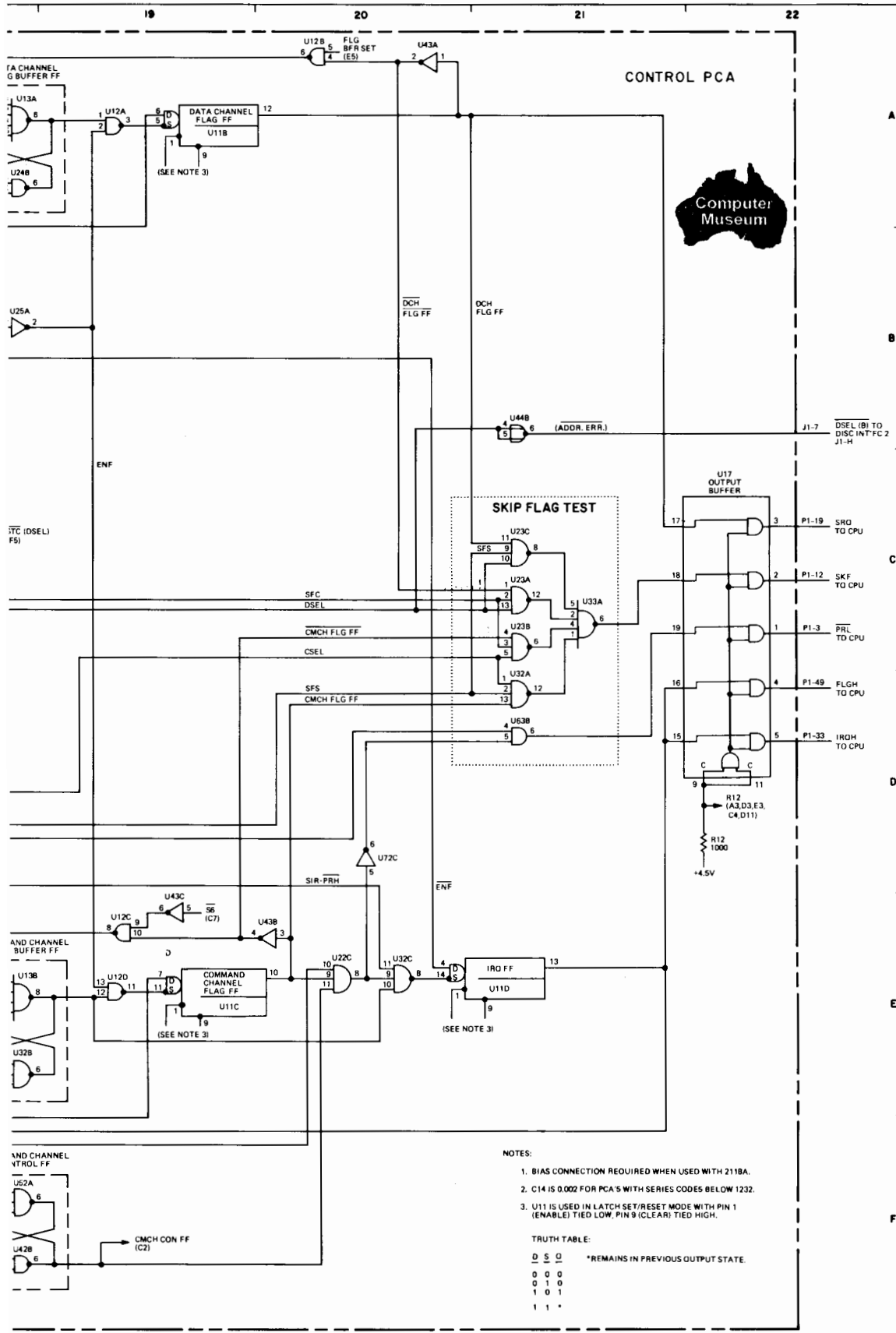
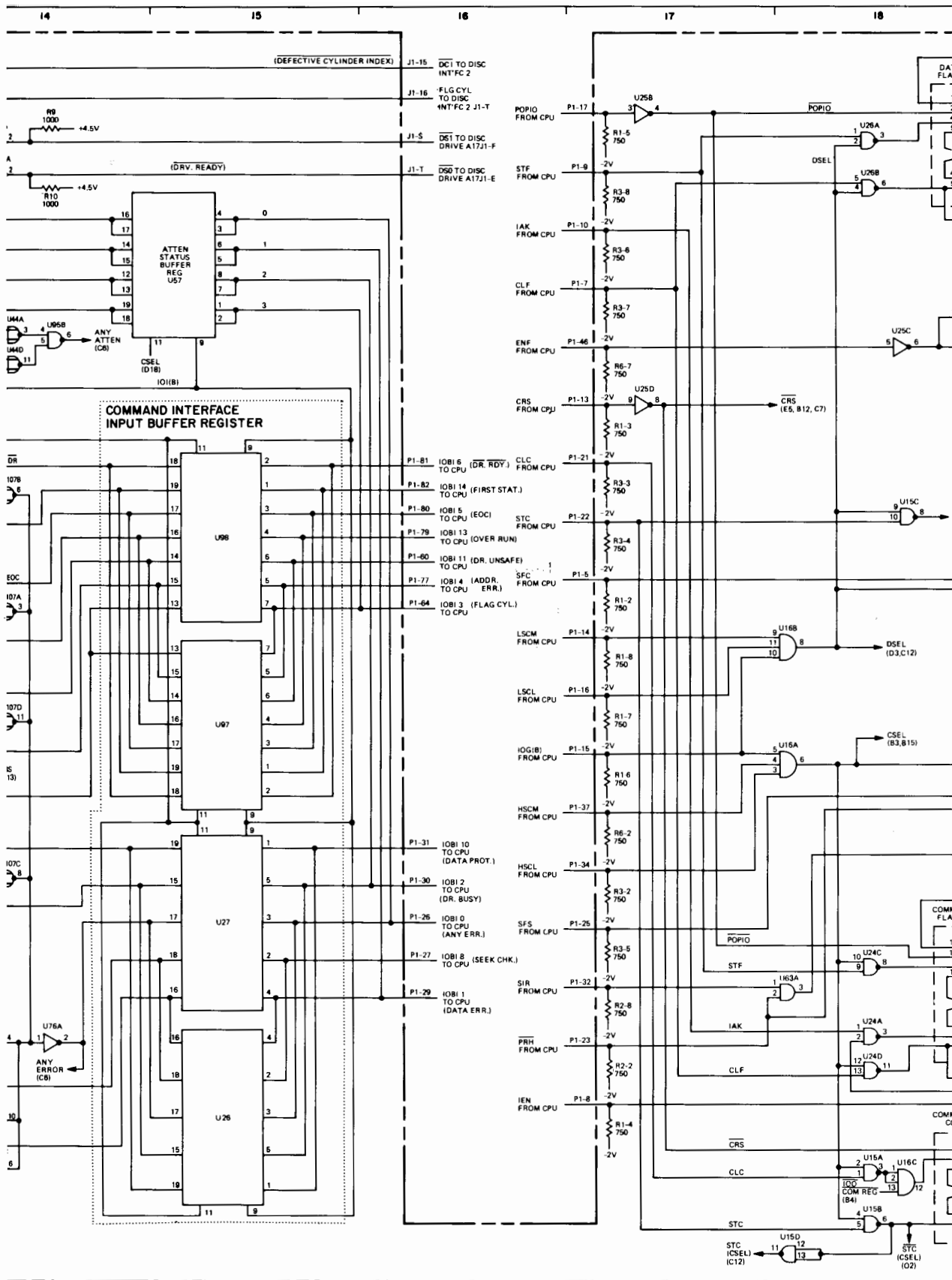

Figure 5-2. Disc Interface 1 PCA Schematic Diagram



14

15

16

17

18

(DEFECTIVE CYLINDER INDEX)

J1-15 DC1 TO DISC INT'FC 2

J1-16 FLG CYL TO DISC INT'FC 2 J1-T

J1-5 DC1 TO DISC DRIVE A17J1-E

J1-T D50 TO DISC DRIVE A17J1-E

(DRV. READY)

COMMAND INTERFACE INPUT BUFFER REGISTER

P1-81 IO(B) 6 (DR. RDY.) TO CPU

P1-82 IO(B) 14 TO CPU (FIRST STAT.)

P1-80 IO(B) 5 TO CPU (EOCI)

P1-79 IO(B) 13 TO CPU (OVER RUN)

P1-60 IO(B) 11 (DR. UNSAFE) TO CPU

P1-77 IO(B) 4 (ADDR. TO CPU (ERR.))

P1-64 IO(B) 3 (FLAG CYL.) TO CPU

P1-31 IO(B) 10 TO CPU (DATA PROT.)

P1-30 IO(B) 2 TO CPU (DR. BUSY)

P1-26 IO(B) 0 TO CPU (ANY ERR.)

P1-27 IO(B) 8 TO CPU (SEEK CHK.)

P1-29 IO(B) 1 TO CPU (DATA ERR.)

POPIO FROM CPU

STF FROM CPU

IAK FROM CPU

CLF FROM CPU

ENF FROM CPU

CRS FROM CPU

CLC FROM CPU

STC FROM CPU

LSCM FROM CPU

LSCL FROM CPU

IOG(B) FROM CPU

HSCM FROM CPU

HSCL FROM CPU

SFS FROM CPU

SIR FROM CPU

PRH FROM CPU

IEN FROM CPU

DA-FLA

POPIO

DSEL

U25C

CRS (E5, B12, C7)

U15C

DSEL (D3, C12)

CSEL (B3, B15)

COMM-FLAC

POPIO

STF

IAK

COMM-COI

CLF

COMM-COI

CRS

CLC

STC

STC (CSEL) (C12)

STC (CSEL) (O2)

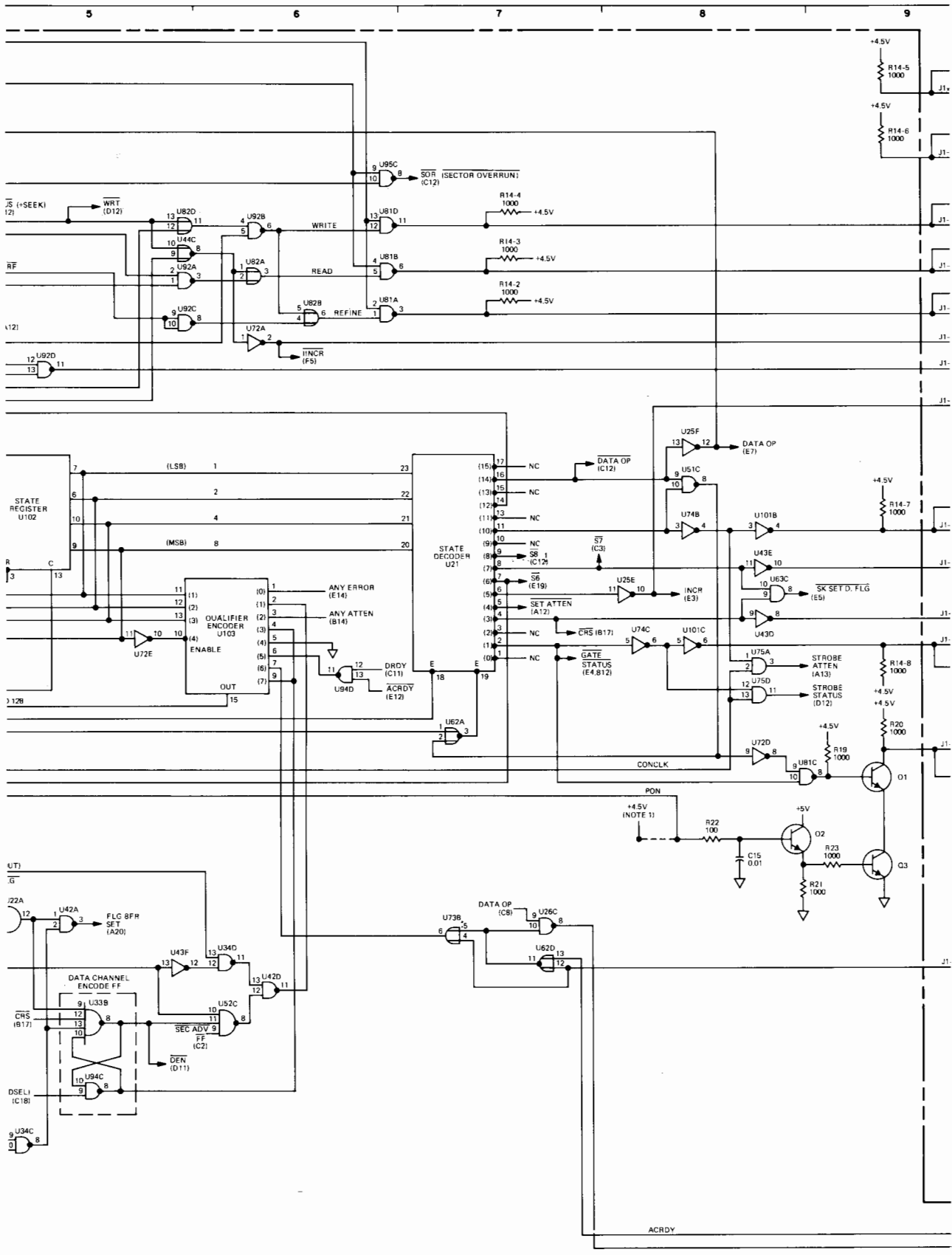

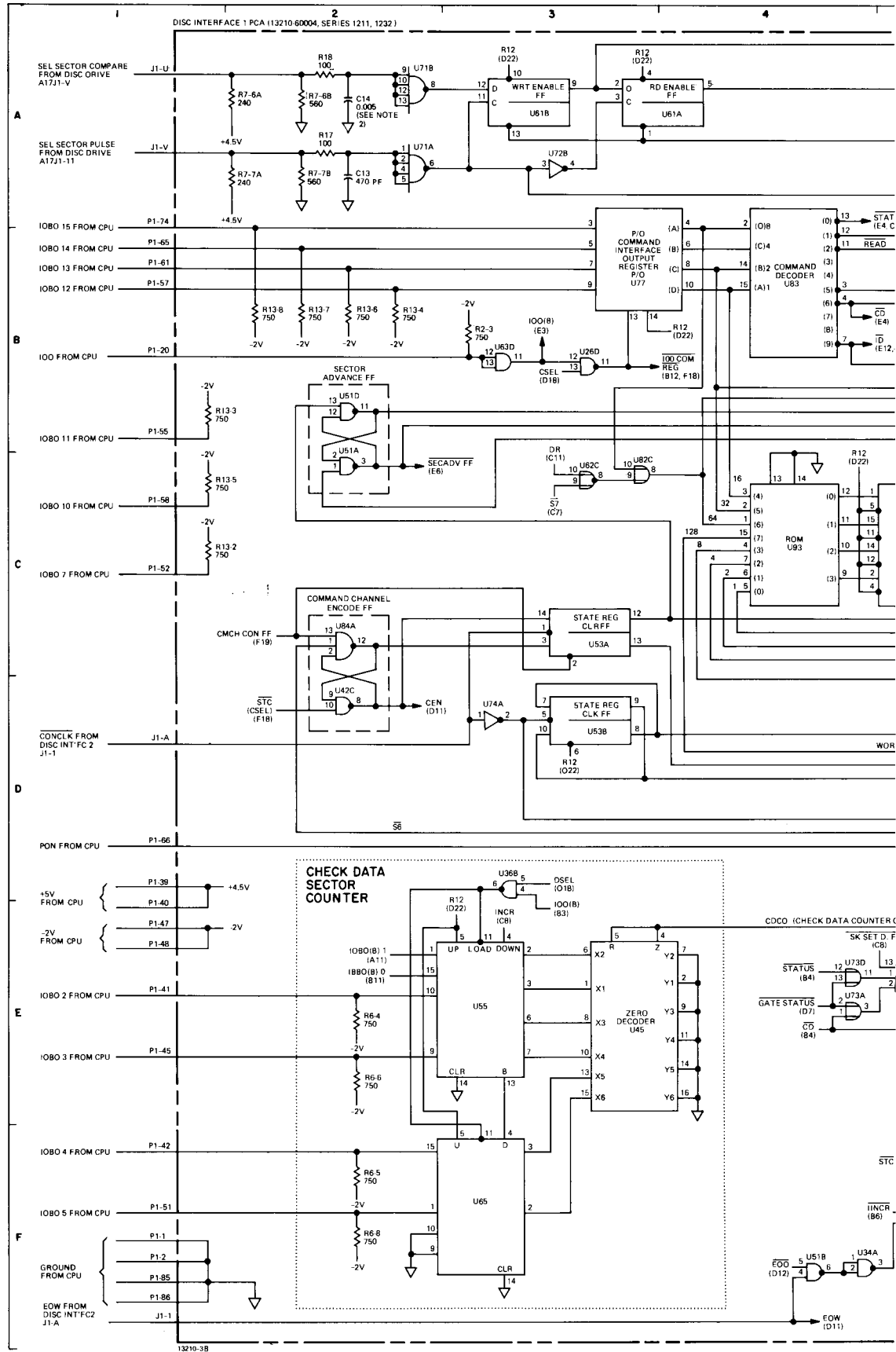
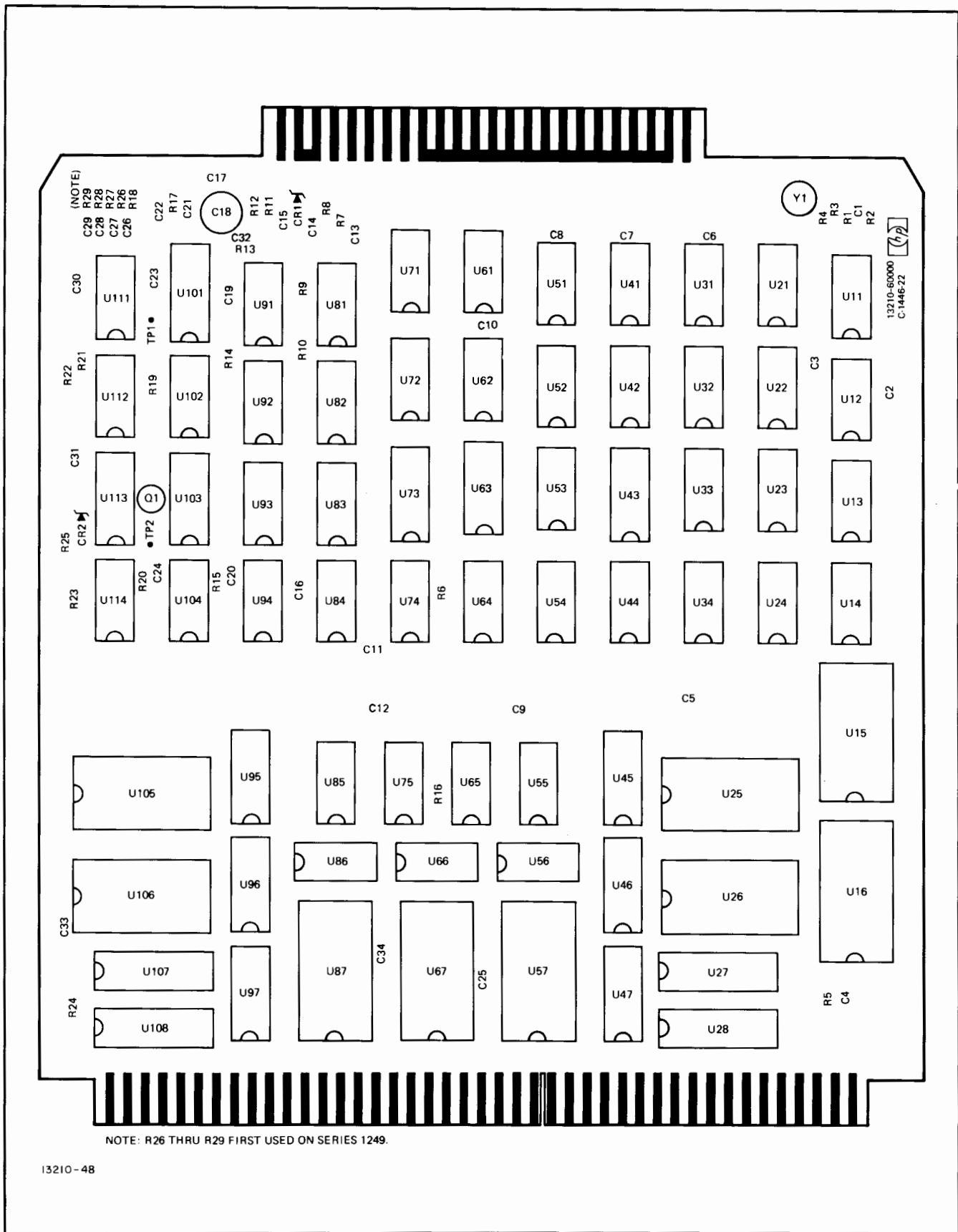

Table 5-3. Disc Interface 2 PCA (13210-60000) Replaceable Parts

REFERENCE DESIGNATION	HP PART NO.	DESCRIPTION	MFR CODE	MFR PART NO.
	13210-60000	DISC INTERFACE 2 PCA	28480	13210-60000
C1	0140-0198	CAPACITOR, fxd, mica, 200 pF, 5%	72136	RDM15F201J3C
C2 thru C14, 16, 20, 24, 25, 32 thru 34	0160-2055	CAPACITOR, fxd, cer, 0.01 μ F, +80 -20%, 100 VDCW	56289	C023F101F103 ZS22-CDH
C15, 19, 21, 22	0150-0121	CAPACITOR, fxd, cer, 0.1 μ F, +80 -20%, 50 VDCW	56289	5C50BIS-CML
C26 thru C29*	0160-3277	CAPACITOR, fxd, cer, 0.01 μ F, 20%, 50 VDCW	96733	G504BX103M
C17 (below series 1438)	0160-2204	CAPACITOR, fxd, mica, 100 pF, 5%	72136	RDM15F111J3C
C17 (series 1438 & above)	0160-2202	CAPACITOR, fxd, mica, 75 pF, 5%, 300 VDCW	28480	0160-2202
C18 (below series 1446)	0121-0046	CAPACITOR, vari, cer, 9-35 pF	28480	0121-0046
C18 (series 1446 & above)	0121-0178	CAPACITOR, vari, cer, 15-60 pF	72982	538-011F15-60
C23	0160-3456	CAPACITOR, fxd, cer, 0.001 μ F, 10%, 250 VDCW	56289	C067F251F102
C30, 31	0160-0161	CAPACITOR, fxd, My, 0.01 μ F, 10%, 200 VDCW	56289	192P10392-PTS
CR1	1902-0041	DIODE, breakdown, 5.11V, 5%	04713	SZ10939-98
CR2	1902-0049	DIODE, breakdown, 6.19V	04713	SZ10939-122
Q1	1854-0045	TRANSISTOR	04713	2N956
R1, 3, 5, 6, 14 thru 18, 20, 23	0683-1025	RESISTOR, fxd, comp, 1000 ohms, 5%, 1/4W	01121	CB 1025
R2, 4	0683-1825	RESISTOR, fxd, comp, 1800 ohms, 5%, 1/4W	01121	CB 1825
R7, 8	0757-0417	RESISTOR fxd, met flm, 562 ohms, 1%, 1/8W	28480	0757-0417
R9, 10	0757-0398	RESISTOR, fxd, met flm, 75 ohms, 1%, 1/8W	28480	0757-0398
R11, 13	0683-5625	RESISTOR, fxd, comp, 5.6k, 5%, 1/4W	01121	CB 5625
R12	0757-0279	RESISTOR, fxd, met flm, 3.16k, 1%, 1/8W	28480	0757-0279
R19	0683-3915	RESISTOR, fxd, comp, 390 ohms, 5%, 1/4W	01121	CB 3915
R21, 22	0698-3446	RESISTOR, fxd, met flm, 383 ohms, 1%, 1/8W	28480	0698-3446
R24	0811-0988	RESISTOR, fxd, ww, 82 ohms, 3%, 3W	28480	0811-0988
R25	0686-1215	RESISTOR, fxd, comp, 120 ohms, 1/2W	19701	MF7C, T-O
R26 thru R29**	0698-7236	RESISTOR, fxd, flm, 1k, 2%, 1/8W	28480	0698-7236
U11	1820-0099	INTEGRATED CIRCUIT, TTL	01295	SN7493N
U12	1820-0070	INTEGRATED CIRCUIT, TTL	01295	SN7430N
U13, 14, 32, 53	1820-0239	INTEGRATED CIRCUIT, TTL	28480	1820-0239
U15, 16, 25, 26, 57 67, 87, 105, 106	1820-0726	INTEGRATED CIRCUIT, TTL	01295	SN74199
U21, 61	1820-0174	INTEGRATED CIRCUIT, TTL	01295	SN7404N
U22, 33, 51, 64, 72, 82, 85, 86, 92	1820-0054	INTEGRATED CIRCUIT, TTL	01295	SN7400N
U23	1820-0282	INTEGRATED CIRCUIT, TTL	01295	SN7486N
U24, 34, 42, 62, 71	1820-0141	INTEGRATED CIRCUIT, TTL	04713	MC3001P
U27, 28, 107, 108	1820-0758	INTEGRATED CIRCUIT	28480	1820-0758
U31, 52	1820-0068	INTEGRATED CIRCUIT, TTL	12040	SN7410N
U41, 55	1820-0544	INTEGRATED CIRCUIT, TTL	01295	SN74H103N
U43, 63, 113	1820-0233	INTEGRATED CIRCUIT, TTL	01295	SN74193N
U44	1820-0374	INTEGRATED CIRCUIT, TTL	01295	SN74H21N
U45, 95	1820-0250	INTEGRATED CIRCUIT, TTL	28480	1820-0250
U46, 47, 96, 97	1820-0616	INTEGRATED CIRCUIT, TTL	07263	U78932259X
U54, 75	1820-0128	INTEGRATED CIRCUIT, DTL	04713	MC837P
U56, 66	1820-0455	INTEGRATED CIRCUIT, TTL	18324	N8288A
U65	1820-0418	INTEGRATED CIRCUIT, DTL	28480	1820-0418
U73, 103	1820-0727	INTEGRATED CIRCUIT, TTL	07263	U7B932159X
U74, 84, 94, 104, 114	1820-0621	INTEGRATED CIRCUIT, TTL	01295	SN7438N
U81	1820-0722	INTEGRATED CIRCUIT, TTL	01295	SN75109N
U83, 93	1820-0637	INTEGRATED CIRCUIT, TTL	18324	N8875A
U91	1820-0723	INTEGRATED CIRCUIT, TTL	01295	SN75107N
U101	1826-0047	INTEGRATED CIRCUIT	18324	NE562B
U102, 112	1820-0077	INTEGRATED CIRCUIT, TTL	01295	SN7474N
U111	1820-0075	INTEGRATED CIRCUIT, TTL	01295	SN7473N
Y1	0410-0436	CRYSTAL, quartz, 10 MHz	28480	0410-0436
*C26 thru C29 (below series 1249)	0150-0121	CAPACITOR, fxd, cer, 0.1 μ F, +80 -20%, 50 VDCW	56289	5C50BIS-CML
**R26 thru R29 (below series 1249)	-	Not Used		



NOTE: R26 THRU R29 FIRST USED ON SERIES 1249.

13210-48

Figure 5-3. Disc Interface 2 PCA Parts Location Diagram

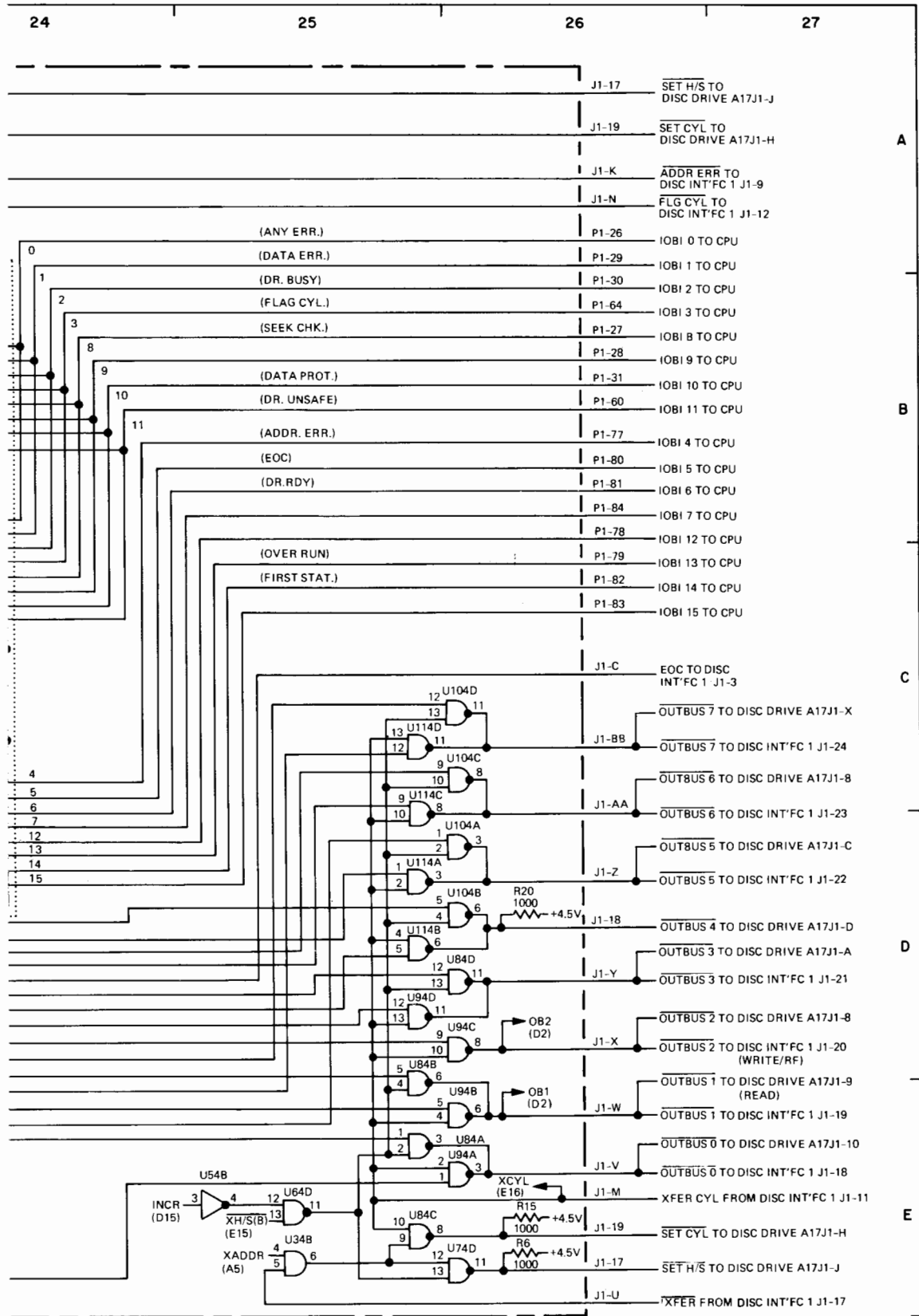
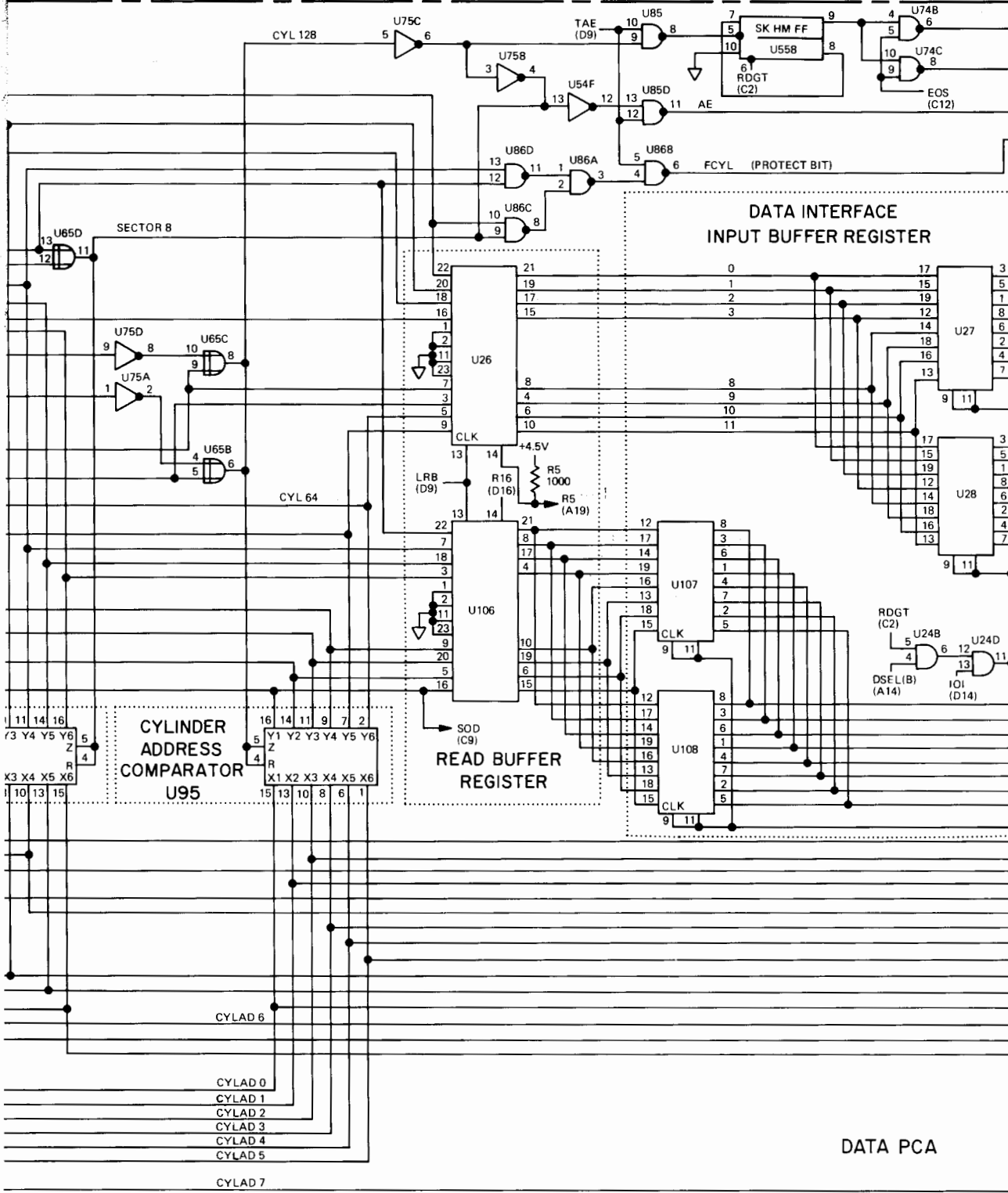

Figure 5-4. Disc Interface 2 PCA Schematic Diagram

21

22

23



DATA PCA

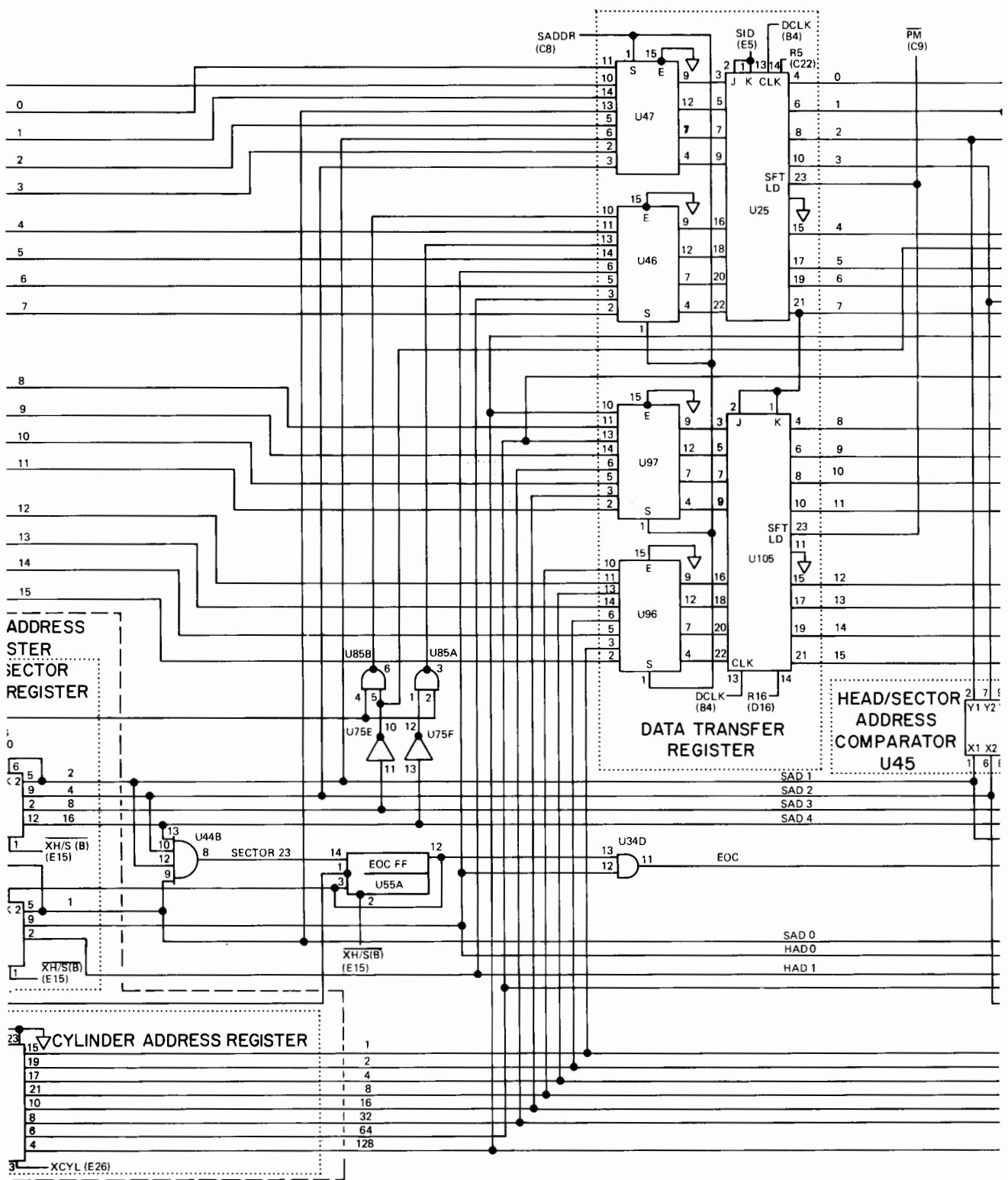

13

14

15

16

CONTROL CLK TO DISC INT'FC 1 J1-A

DSEL (B) FROM DISC INT'FC 1 J1-7

IOO FROM CPU P1-20

FLG CYL FROM DISC INT'FC 1 J1-16

DATA 2 TO DISC DRIVE A17J1-C

IOBO 0 FROM CPU P1-35

IOBO 1 FROM CPU P1-38

DATA 1 TO DISC DRIVE A17J1-D

IOBO 2 FROM CPU P1-41

IOBO 3 FROM CPU P1-45

IOBO 4 FROM CPU P1-42

IOBO 5 FROM CPU P1-51

IOBO 6 FROM CPU P1-53

IOBO 7 FROM CPU P1-52

IOBO 8 FROM CPU P1-54

IOBO 9 FROM CPU P1-56

IOBO 10 FROM CPU P1-58

IOBO 11 FROM CPU P1-55

IOBO 12 FROM CPU P1-57

EOS TO INT'FC 1 J1-14

IOBO 13 FROM CPU P1-61

IOBO 14 FROM CPU P1-65

IOBO 15 FROM CPU P1-74

EOD FROM DISC INT'FC 1 J1-8B

DCI FROM DISC INT'FC 1 J1-15

IOI FROM CPU P1-24 → IOI (C24)

EOS TO DISC INT'FC 1 J1-1

INCR FROM DISC INT'FC 1 J1-F

INCR FROM DISC INT'FC 1 J1-D

SET DATA ERR TO DISC INT'FC 1 J1-2

XFR H/S FROM DISC INT'FC 1 J1-6

DATA INTERFACE OUTPUT * BUFFER REGISTER (*FROM CUP)

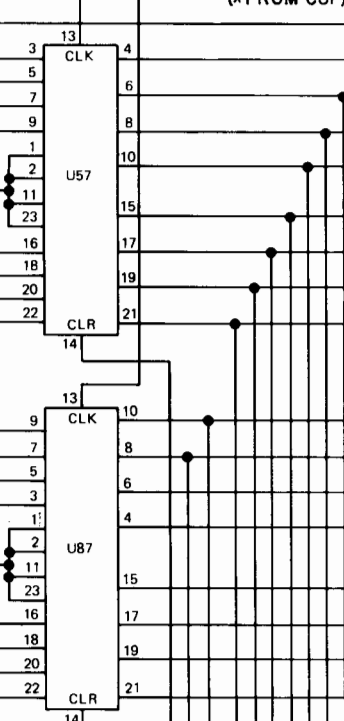

RECORD REGI HEAD/ ADDRESS +4.5V

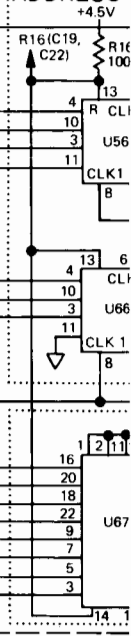

X H/S(B) (E16, E17, E25, D16)

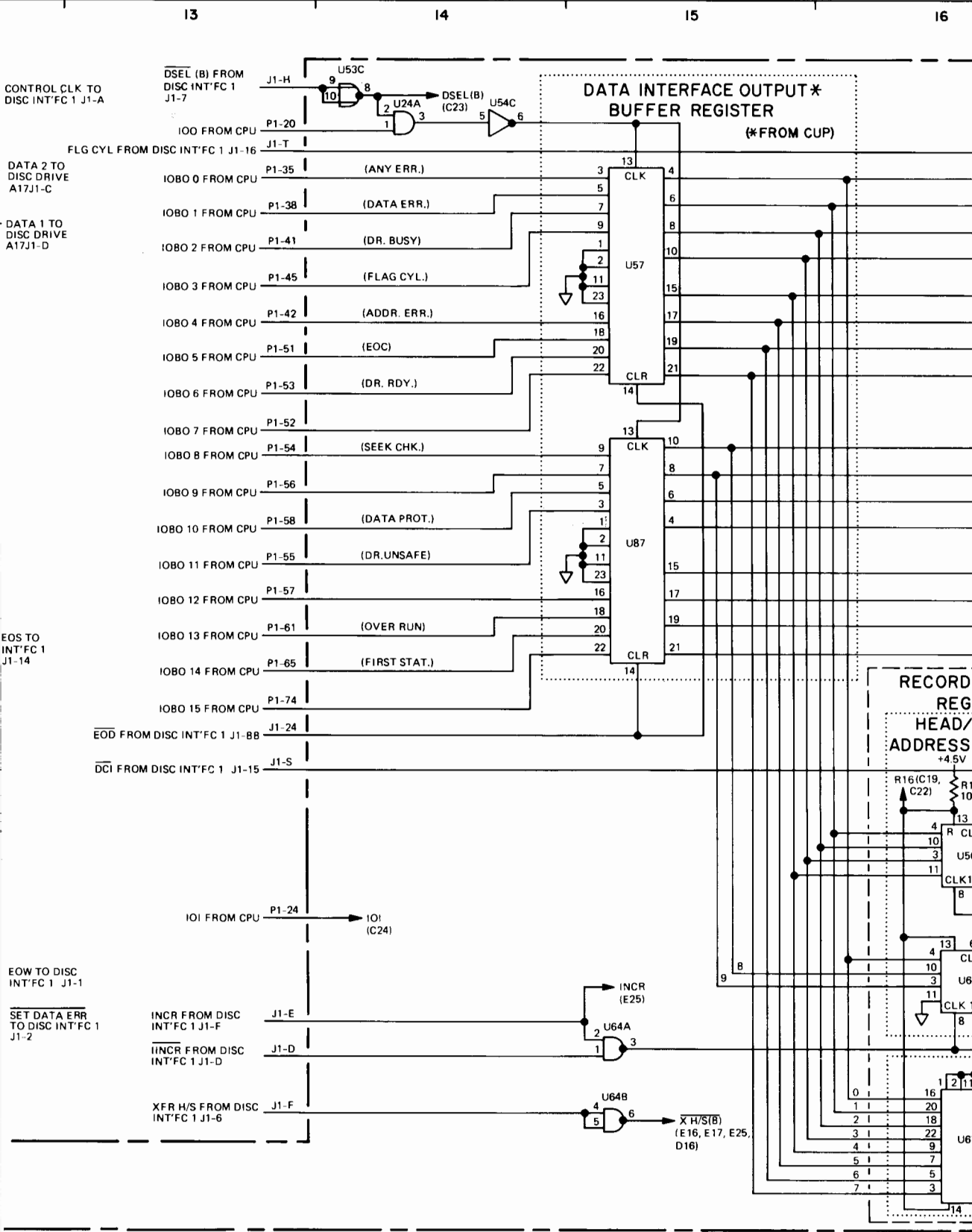

9

10

11

12

CONCLK
(A5)

J1-1

J1-20

J1-21

CYCLIC CHECK SECTOR COUNTER

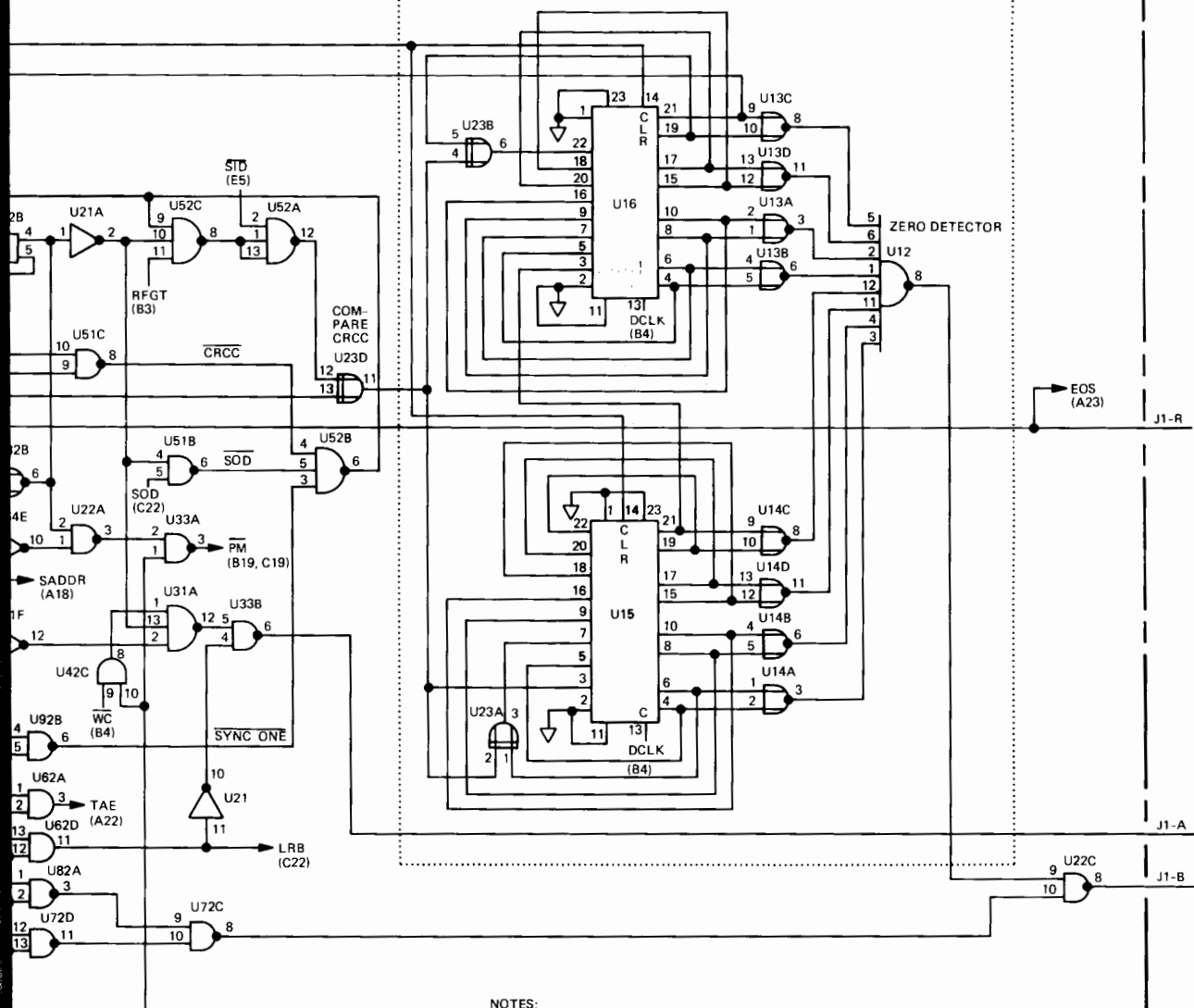

NOTES:

1. C26 THRU C29 ARE 0.1 μ F ON PCA'S WITH SERIES CODES BELOW 1249.
2. R26 THRU R29 NOT PRESENT ON PCA'S WITH SERIES CODES BELOW 1249.
3. C17 IS 100PF ON SERIES CODE 1249 AND OLDER, 75pF ON SERIES CODE 1438 AND ABOVE.
4. C18 IS 9-35pF ON SERIES CODE 1438 AND OLDER, 15-60 pF ON SERIES CODE 1446 AND ABOVE.

5

6

7

8

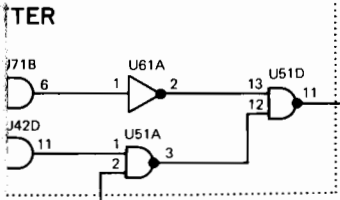
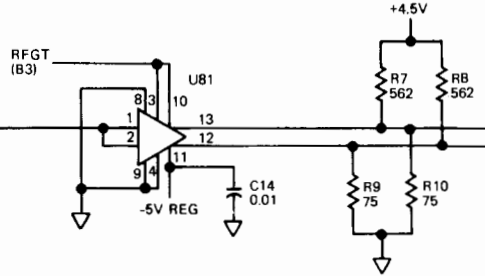
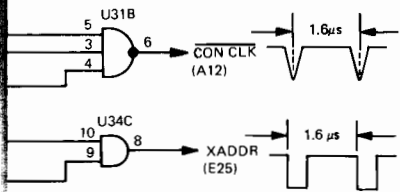

0. C10, A19, D19)

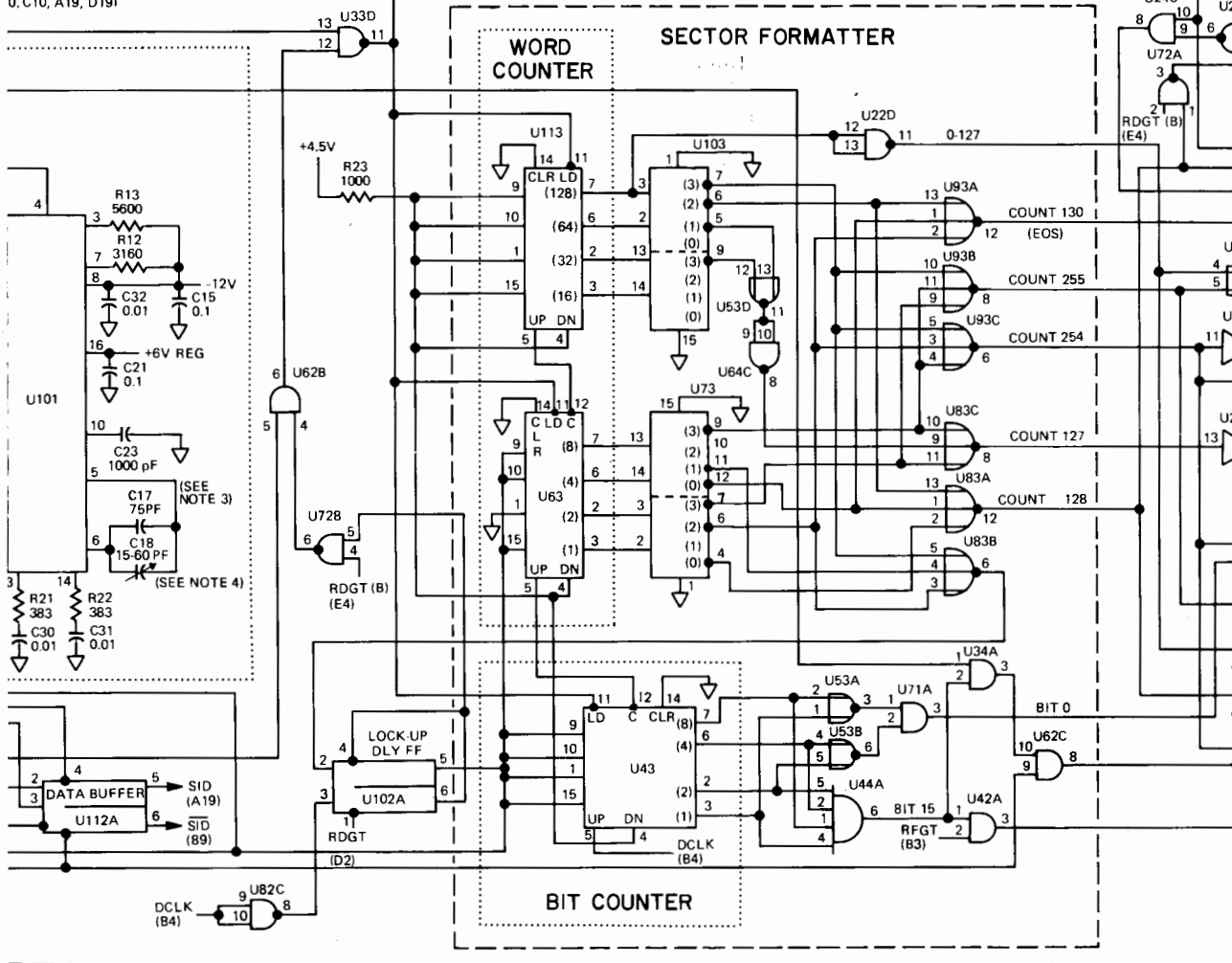

WORD COUNTER

SECTOR FORMATTER

BIT COUNTER

Table 5-4. Interconnecting Cable Plug-to-Plug Connections

DISC INTERFACE 1 (P1) PIN	CONNECTS TO	DISC INTERFACE 2 (P2) PIN	CONNECTS TO	DISC DRIVE (P3) PIN	CONNECTS TO
1	P2-A	1	P1-A	1	P1-13, P2-P
2	P2-B	2	Common	2	P1-18, P2-V
3	P2-C	3	Common	3	P1-21, P2-Y
4	P3-V	4	Common	4	Common
5	P3-W	5	Common	5	Common
6	P2-F	6	Common	6	Common
7	P2-H	7	Common	7	Common
8	P3-U	8	Common	8	Common
9	P2-K	9	Common	9	Common
10	P3-R	10	Common	10	Common
11	P2-M	11	Common	11	Common
12	P2-N	12	Common	12	Common
13	P2-P, P3-1	13	Common	13	Common
14	P2-R	14	Common	14	Common
15	P2-S	15	Common	15	Common
16	P2-T	16	Common	16	Common
17	P2-U	17	P3-B	17	Common
18	P2-V, P3-2	18	P3-H	18	Common
19	P2-W, P3-A	19	P3-C	19	Common
20	P2-X, P3-S	20	P3-Z, P3-22	20	Common
21	P2-Y, P3-3	21	P3-Y	21	Common
22	P2-Z, P3-J	22	NC	22	P3-Z
23	P2-AA, P3-K	23	NC	23	NC
24	P2-BB, P3-D	24	P1-BB	24	Shield
A	P2-1	A	P1-1	A	P1-19, P2-W
B	NC	B	P1-2	B	P2-17
C	NC	C	P1-3	C	P2-19
D	P2-D	D	P1-D	D	P1-BB, P2-24
E	NC	E	P1-F	E	P1-S
F	P2-E	F	P1-6	F	P1-T
H	P3-T	H	P1-7	H	P2-18
J	P3-U	J	NC	J	P1-22, P2-Z
K	NC	K	P1-9	K	P1-23, P2-AA
L	NC	L	NC	L	NC
M	P3-X	M	P1-11	M	P1-V
N	P3-P	N	P1-12	N	P1-U
P	NC	P	P1-13	P	P1-N
R	NC	R	P1-14	R	P1-10
S	P3-E	S	P1-15	S	P1-20, P2-X
T	P3-F	T	P1-16	T	P1-H
U	P3-N	U	P1-17	U	P1-8
V	P3-M	V	P1-18, P3-2	V	P1-4
W	NC	W	P1-19, P3-A	W	P1-5
X	NC	X	P1-20, P3-S	X	P1-M
Y	NC	Y	P1-21, P3-3	Y	P2-21
Z	NC	Z	P1-22, P3-J	Z	P2-20, P3-22
AA	NC	AA	P1-23, P3-K	AA	NC
BB	P2-24	BB	P1-24, P3-D	BB	Shield

SECTION VI

REPLACEABLE PARTS

6-1. INTRODUCTION.

6-2. This section provides information for ordering replacement parts for the disc drive interface kit. Separate parts lists and parts location diagrams are provided for each printed-circuit assembly in section V of this manual. Parts are listed in these tables in alphanumeric order by reference designation. Table 6-1 is a complete parts list for the disc drive interface kit.

6-3. Table 6-1 lists the following information for each part:

a. Hewlett-Packard part number.

b. Description of the part. (Refer to table 6-2 for an explanation of abbreviations used in the DESCRIPTIONS column.)

c. Typical manufacturer of the part as a five-digit code. (Refer to table 6-3 for a listing of the manufacturers that correspond to the codes.)

d. Manufacturer's part number.

6-4. ORDERING INFORMATION.

6-5. To order replacement parts, address the order or inquiry to the local HP Sales and Service Office. (Refer to the list at the back of this manual.) Specify the following information for each part ordered.

a. Kit model number.

b. HP stock number for each part.

c. Description of each part.

Table 6-1. HP 13210A Disc Drive Interface Kit Replaceable Parts

HP PART NO.	DESCRIPTION	MFR CODE	MFR PART NO.	TQ
13210-60000	DISC INTERFACE 2 PCA (Refer to table 5-3.)	28480	13210-60000	1
13210-60003	INTERFACE CABLE	28480	13210-60003	1
13210-60004	DISC INTERFACE 1 PCA (Refer to table 5-2.)	28480	13210-60004	1
13210-90003	OPERATING AND SERVICE MANUAL	28480	13210-90003	1

Table 6-2. Reference Designations and Abbreviations

REFERENCE DESIGNATIONS		
A = assembly	K = relay	TB = terminal board
B = motor, synchro	L = inductor	TP = test point
BT = battery	M = meter	U = integrated circuit, non-repairable assembly
C = capacitor	P = plug connector	V = vacuum tube, photocell, etc.
CB = circuit breaker	Q = semiconductor device other than diode or microcircuit	VR = voltage regulator
CR = diode	R = resistor	W = cable, jumper
DL = delay line	RT = thermistor	X = socket
DS = indicator	S = switch	Y = crystal
E = Misc electrical parts	T = transformer	Z = tuned cavity, network
F = fuse		
FL = filter		
J = receptacle connector		
ABBREVIATIONS		
A = amperes	gra = gray	PCA = printed-circuit assembly
ac = alternating current	grn = green	PWB = printed-wiring board
ad = anode		ph = Phillips head
Al = aluminum	H = henries	pk = peak
AR = as required	Hg = mercury	p-p = peak-to-peak
adj = adjust	hr = hour(s)	pt = point
assy = assembly	Hz = hertz	PIV = peak inverse voltage
	hdw = hardware	PNP = positive-negative-positive
B = base	hex = hexagon, hexagonal	PWV = peak working voltage
bp = bandpass		porc = porcelain
bpi = bits per inch	ID = inside diameter	posn = position(s)
blk = black	IF = intermediate frequency	pozi = pozidrive
blu = blue	in. = inch, inches	
brn = brown	I/O = input/output	rf = radio frequency
brs = brass	int = internal	rdh = round head
Btu = British thermal unit	incl = include(s)	rmo = rack mount only
Be Cu = beryllium copper	insul = insulation, insulated	rms = root-mean-square
	impgrg = impregnated	RWV = reverse working voltage
C = collector	incand = incandescent	rect = rectifier
cw = clockwise	ips = inches per second	r/min = revolutions per minute
ccw = counterclockwise		RTL = resistor-transistor logic
cer = ceramic	k = kilo (10 ³), kilohm	
cmo = cabinet mount only	lp = low pass	s = second
com = common	m = milli (10 ⁻³)	SB, TT = slow blow
crt = cathode-ray tube	M = mega (10 ⁶), megohm	Se = selenium
CTL = complementary-transistor logic	My = Mylar	Si = silicon
	mfr = manufacturer	scr = silicon controlled rectifier
cath = cathode	mom = momentary	sil = silver
cd pl = cadmium plate	mtg = mounting	sst = stainless steel
comp = composition	misc = miscellaneous	stl = steel
conn = connector	Met Ox = metal oxide	spcl = special
compl = complete	mintr = miniature	spdt = single-pole, double-throw
		spst = single-pole, single-throw
dc = direct current	n = nano (10 ⁻⁹)	semicond = semiconductor
dr = drive	n.c. = normally closed or no connection	
DTL = diode-transistor logic	Ne = neon	Ta = tantalum
depc = deposited carbon	no. = number	td = time delay
dpdt = double-pole, double-throw	n.o. = normally open	Ti = titanium
dpst = double-pole, single-throw	np. = nickel plated	tgl = toggle
	NPN = negative-positive-negative	thd = thread
E = emitter	NPO = negative-positive zero (zero temperature coefficient)	tol = tolerance
ECL = emitter-coupled logic	NSR = not separately replaceable	TTL = transistor transistor logic
ext = external	NRFR = not recommended for field replacement	
encap = encapsulated		U(μ) = micro (10 ⁻⁶)
elctlt = electrolytic		V = volt(s)
	OD = outside diameter	var = variable
F = farads	OBD = order by description	vio = violet
FF = flip-flop	orn = orange	VDCW = direct current working volts
flh = flat head	ovh = oval head	
Fim = film	oxd = oxide	W = watts
Fxd = fixed		ww = wirewound
filh = fillister head		wht = white
		WIV = working inverse voltage
G = giga (10 ⁹)	p = pico (10 ⁻¹²)	yel = yellow
Ge = germanium	PC = printed circuit	
gl = glass		
gnd = ground(ed)		

Table 6-3. Code List of Manufacturers

CODE NO.	MANUFACTURER	ADDRESS
01121	Allen Bradley Co.	Milwaukee, Wisconsin
01295	Texas Instruments Inc. Semiconductor Components Div.	Dallas, Texas
04713	Motorola Semiconductor Prod. Inc.	Phoenix, Arizona
07263	Fairchild Camera & Inst. Corp. Semiconductor Div.	Mountain View, California
12040	National Semiconductor Corp.	Danbury, Connecticut
18324	Signetics Corp.	Sunnyvale, California
19701	Mepco/Electra Inc. Electra Div.	Mineral Wells, Texas
28480	Hewlett-Packard Company	Palo Alto, California
56289	Sprague Electric Co.	N. Adams, Massachusetts
72136	Electro Motive Mfg. Co. Inc.	Willimantic, Connecticut
72982	Erie Technological Prod. Inc.	Erie, Pennsylvania
80131	Electronic Industries Association	Washington D.C.
91418	Radio Materials Co.	Chicago, Illinois
96733	San Fernando Electric Mfg. Co.	San Francisco, California

APPENDIX A

BACKDATING INFORMATION

This backdating appendix provides information for making this manual applicable to earlier versions of HP 13210A Disc Drive Interface Kits. Changes are identified numerically

in this appendix. Refer to the following table to determine which changes should be made to achieve a particular kit version.

Description	Part Number	Series	Changes
Disc Interface 2 PCA	13210-60000	1135	1, 2, 3
Disc Interface 2 PCA	13210-60000	1138	3
Disc Interface 1 PCA	13210-60004	1135	4, 5

<u>CHANGE</u>	<u>DESCRIPTION</u>
1	Pages 5-4 and 5-7; table 5-2 and figure 5-4. Change C17 from 100 pF, part no. 0160-2204 to 110 pF, part no. 0140-0194.
2	Page 5-7, figure 5-4. a. Add connection between U112B pin 12 and U61C pin 5; delete the connection between U112B pin 12 and U61B pin 4. b. Delete U54A from the circuit and connect U32A pin 1 to U32A pin 2.
3	Page 5-4, table 5-2; page 5-7, figure 5-4. Change R11 and R13 from 5.6k, part no. 0683-5625 to 12k, part no. 0683-1235.
4	Page 5-3, figure 5-2. Add connection between U35D pin 13 and U52A pin 1. Delete $\overline{\text{CRS}}$ signal connection from State Decoder, U21 pin 4.
5	Page 5-3, figure 5-2. Delete connection between U52A pin 13 and pin 2. Add connection between U36A pin 3 (near IOI input) and U52A pin 13.



MANUAL PART NO. 13210-90003
MICROFICHE PART NO. 13210-90008

PRINTED IN U.S.A.