

HP 1000 Computer Systems

Communications products technical data

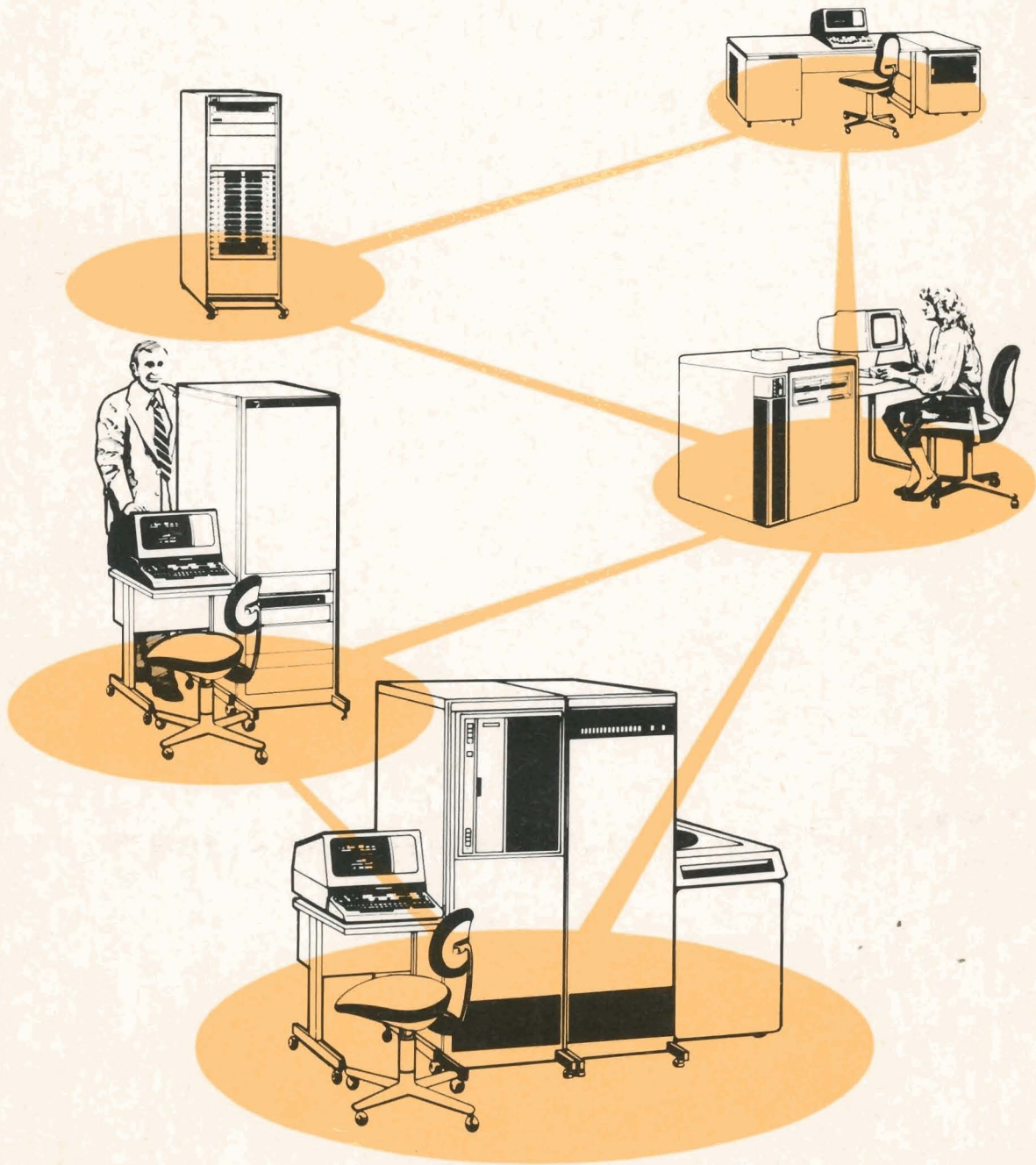

Product number index

Product No. & Name	Page	Applies To Series
12005A Asynchronous serial interface	3-0	L
12007A HDLC Network Modem interface	1-11	L
12044A HDLC Direct connect interface	1-11	L
12531C Teleprinter interface	3-2	M/E/F
12531D Terminal interface	3-2	M/E/F
12587B Asynchronous communications interface	3-4	M
12589A Automatic calling unit interface	3-8	M
12618A Synchronous communications interface	3-6	M/E/F
12771A Computer serial interface	5-10	M/E/F
12773A Computer modem interface	5-12	M/E/F
12790A Multipoint terminal subsystem interface	2-6	M/E/F
12792A 8-Channel Asynchronous multiplexer subsystem	2-9	M/E/F
12793A Bisync modem interface	1-15	M/E/F
12794A HDLC Network modem interface	1-11	M/E/F
12825A HDLC Direct connect interface	1-11	M/E/F
12828A RS-232C Multiplexer panel	2-11	
12880A CRT terminal interface	3-2	M/E/F
12889A Hardwired serial interface	1-17	M/E/F
12920B 16-channel Asynchronous multiplexer	2-15	M/E/F
12966A Buffered async communications interface	3-4	M/E/F
12967A Synchronous communications interface	3-6	M/E/F
12968A Asynchronous communications interface	3-4	M/E/F
30220A Cable kit for use w/12889A interface	1-17	M/E/F
37210T 4800 bps Synchronous modem	4-1	L/M/E/F
37220T 9600 bps Synchronous modem	4-1	L/M/E/F
37230A Short haul modem	4-1	L/M/E/F
91720A Communications cable for 12771A with unassembled connectors	5-10	M/E/F
91721A Communications cable for 12771A with assembled connectors	5-10	M/E/F
91730A Multipoint terminal subsystem software	2-1	M/E/F
91731A Asynchronous multiplexer subsystem software for 12920B	2-12	M/E/F
91740A/B DS/1000 Network software-firmware (MATURE product)	5-0	M/E/F
91741A DS/1000 software enhancement for HP 1000-to-HP 3000 Communication (MATURE product)	5-0	M/E/F
91750A DS/1000-IV Network software	1-0	L/M/E/F
91780A RJE/1000 Remote Job Entry package	1-18	M/E/F

Alphabetical index

Product Name/Topic	Page	Applies To Series
Asynchronous multiplexer subsystem software package for 12920B (91731A)	2-12	M/E/F
Asynchronous multiplexer subsystem, 8 channel (12792A)	2-9	M/E/F
Asynchronous multiplexer, 16 channel (12920B)	2-15	M/E/F
Asynchronous serial interface (12005A)	3-0	L
Asynchronous terminal communications interface (12966A, 12968A, and 12587B)	3-4	M/E/F
Automatic calling unit interface (12589A)	3-8	M
Bisync modem interface (12793A)	1-15	M/E/F
Character mode interfaces (12531C, 12531D, and 12888A)	3-2	M/E/F
Computer modem interface (12773A)	5-12	M/E/F
Computer serial interface (12771A)	5-10	M/E/F
DS/1000 Network software-firmware (MATURE product) (91740A/B and 91741A)	5-0	M/E/F
DS/1000-IV Network software (91750A)	1-0	L/M/E/F
Hardwired serial interface (12889A)	1-17	M/E/F
HDLC Direct connect interface (12044A)	1-11	L
HDLC Direct connect interface (12825A)	1-11	M/E/F
HDLC Network Modem interface (12007A)	1-11	L
HDLC Network Modem interface (12794A)	1-11	M/E/F
Modems selection guide (37210T, 37220T, and 37230A)	4-1	L/M/E/F
Multiplexer panel, RS-232-C (12828A)	2-11	
Multipoint terminal subsystem interface (12790A)	2-6	M/E/F
Multipoint terminal subsystem software (91730A)	2-1	M/E/F
RJE/1000 Remote Job Entry Package (91780A)	1-18	M/E/F
Synchronous communications interfaces (12967A and 12618A)	3-6	M/E/F

HP Computer Museum
www.hpmuseum.net

For research and education purposes only.

HP 1000 Computer Systems Communications Data Locator

System-to-System Communications Software and Interfaces

- 91750A DS/1000-IV Network software 1-0
- 12007A, 12044A, 12794A, and 12825A HP 1000 L-Series and M/E/F-Series HDLC Network Interfaces for DS/1000-IV communication between HP 1000 Systems 1-11
- 12793A HP 1000 M/E/F-Series Binary Synchronous Modem Interface for DS/1000-IV communication between HP 1000 and HP 3000 Systems 1-15
- 12889A HP 1000 M/E/F-Series Hardwired serial interface and cables 1-17
- 91780A RJE/1000 Remote Job Entry Package for HP 1000 M/E/F-Series Computers 1-18

Operator-to-System Communications Software and Interfaces

- 91730A Multipoint Terminal Subsystem Software for HP 1000 M/E/F-Series Computers 2-1
- 12790A HP 1000 M/E/F-Series Multipoint terminal subsystem interface 2-6
- 12792A HP 1000 M/E/F-Series 8-Channel Asynchronous Multiplexer Subsystem 2-9
- 12828A RS-232-C Multiplexer Panel 2-11
- 91731A Asynchronous multiplexer subsystem software package for HP 1000 M/E/F-Series Computers 2-12
- 12920B HP 1000 M/E/F-Series 16-channel Asynchronous multiplexer 2-15

Other Data Communications Interfaces



- 12006A HP 1000 L-Series Asynchronous Serial Interface 3-0
- 12531C, 12531D, and 12880A HP 1000 M/E/F-Series Character mode terminal interfaces 3-2
- 12996A, 12968A, and 12587B HP 1000 M/E/F-Series Asynchronous terminal communications interfaces 3-4
- 12967A and 12618A HP 1000 M/E/F-Series Synchronous communications interface 3-6
- 12589A HP 1000 M-Series Automatic calling unit interface 3-8

Hewlett-Packard Modems Selection Guide

- 37210T, 37220T, and 37230A Hewlett-Packard Modems Selection Guide 4-1

Mature System-to-System Communications Software and Interfaces

- 91740A/B and 91741A DS/1000 Network software-firmware for HP 1000 M/E/F-Series Computers 5-0
- 12771A HP 1000 M/E/F-Series Computer serial interface and cables 5-10
- 12773A HP 1000 M/E/F-Series Computer modem interface 5-12

Distributed Systems/1000-IV (DS/1000-IV) software provides an integrated set of high-level network facilities and procedures for HP 1000 L/M/E/F-Series Computer Systems. These facilities and procedures support network resource sharing, remote data base access, distributed data file management, communication between application programs, and the coordinated distribution of processor workloads to other HP 1000 Computer Systems in the network and/or to HP 3000 Series II/III/30/33 Systems.

Features

- Complete backward compatibility with 91740A/B DS/1000 nodes so applications software which runs on them may be transported and run in 91750A DS/1000-IV nodes and so that existing DS/1000 nodes can communicate with new DS/1000-IV nodes
- Transparent dynamic message rerouting between HP 1000 systems to bypass a "down" node or communications link
- Transparent Message Accounting which guarantees that each message is definitely received and that it is received only once by the user level task to which it is directed (between HP 1000 systems only)
- Transaction logging to facilitate network traffic analysis and fault isolation
- Generalized DS/1000-IV network architecture
- Network support of all HP 1000 Computer Series (L, M, E, and F) operating under RTE-L, RTE-IVB, and RTE-M (MIII configuration)
- Full network communication with HP 3000 Series II/III/30/33 Systems equipped with DS/3000 software, via hardwired and modem links (from HP 1000 M/E/F-Series only)
- Support for new, higher-efficiency microprocessor-based, fully-buffered HDLC and Bisync network interfaces
- Network-wide nodal addressing with store-and-forward between HP 1000 systems for maximum configuration flexibility
- Remote HP 1000 system generation and remote program development
- Remote command processing between any DS/1000-IV network nodes and between DS/1000-IV nodes and an HP 3000 System
- Remote access to IMAGE/1000 data bases at HP 1000 Systems
- HP 1000 virtual terminal capability to HP 3000 Series II/III/30/33 System
- Remote I/O mapping enables unit-record I/O to be directed to/from any unit-record device at any HP 1000 System in the network, thereby offering substantial savings in overall network hardware costs

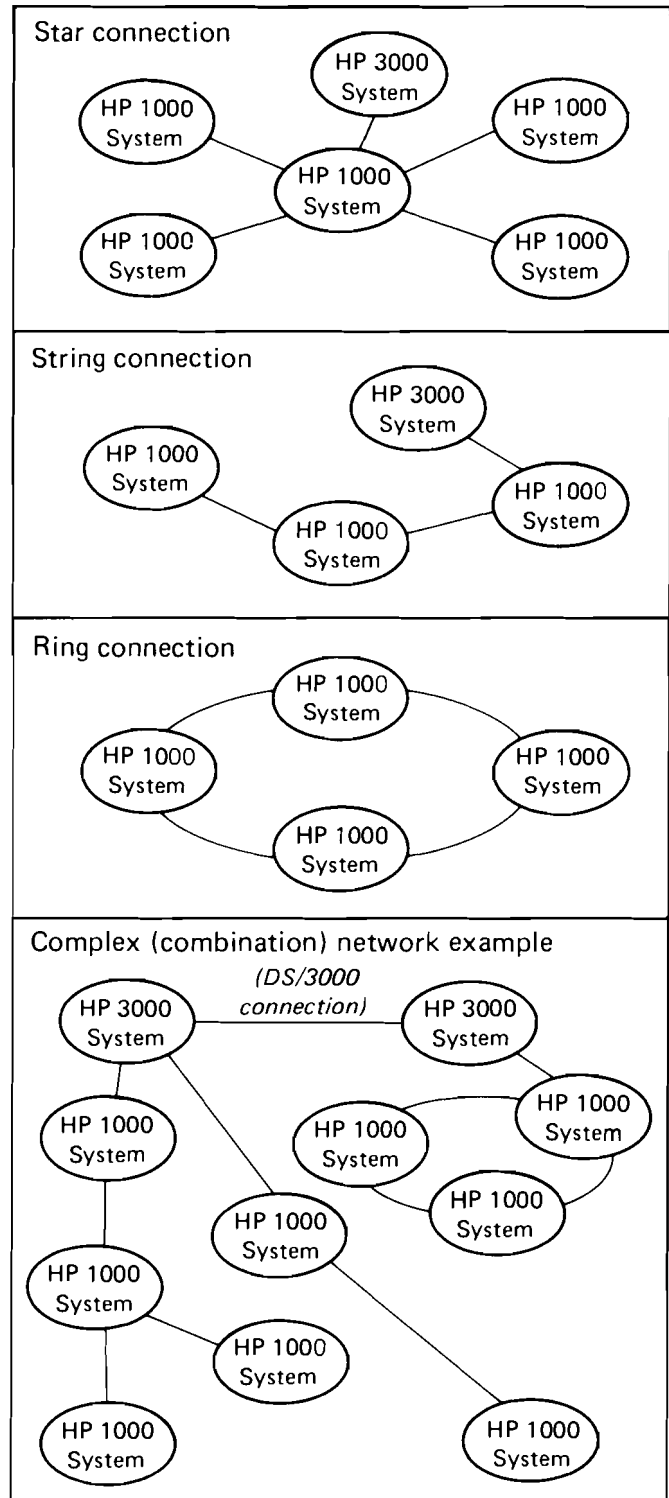

DS/1000 Network configuration choices

Topologically-independent network architecture

Nodal addressing (DS/1000-to-DS/1000 only)

Within a network of interconnected HP 1000 Computer Systems, each system is assigned a unique node identification number by the user. Remote operator commands and user program requests reference the number(s) of the node(s) to which they are directed.

Node numbers for DS/1000 network connections are specified after an RTE operating system has been generated and loaded. A Nodal Routing Vector (NRV), which specifies the Logical Unit (LU) number through which a DS/1000 transaction goes from the local node to the target node, can be specified interactively or read from a file at each DS/1000 node. In each node, this file specifies the logical unit connections required to get to any accessible node, as shown in Figure 1.

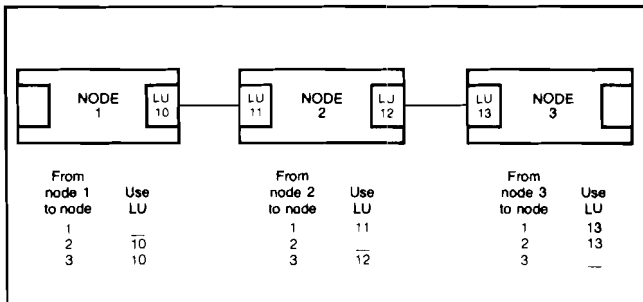

Figure 1. Nodal addressing in DS/1000-IV network

Store and forward operations (DS/1000-to-DS/1000 only)

Using the example of Figure 1, a transaction goes from node 1 to node 2 or 3 via LU10. At node 2, the DS/1000 communications management modules examine the destination node address in the message and either route the message to the local network interface monitors for processing if addressed to node 2, or forward the message to node 3 via LU12. In this way a single communications path is established between any two DS/1000 nodes, regardless of whether there is a direct, neighbor connection between them. Store-and-forward communications are not limited to a specified number of levels. However, store and forward to or through an HP 3000 system is not supported.

Nodal addressing with store-and-forward offers important advantages. Hardwired or modem links can be shared in a string or ring configuration, reducing initial costs for hardwired connections or operating costs for data communications. A program can be written, debugged, and tested in one node and then transported to any other DS/1000 node in the network while accessing the same local or remote peripheral logical units, or slave application programs. No user application programs are required to perform store-and-forward functions in any node.

New network capabilities

Dynamic message rerouting (DS/1000-IV to DS/1000-IV only)

In a network set up with alternate communication paths, DS/1000-IV supports dynamic rerouting of messages that are blocked by failure of a node or communications link. When a node or link failure is detected, the dynamic message rerouting software attempts to locate and set up an alternate communications path. If more than one alternate path exists, the best available route will be selected, using a relative "cost" table prepared by the network manager. As part of this operation, the originating node sends updated routing information to other network nodes. If no alternate path exists, an error message is sent to the user. When the "down" communications path is brought back up, the original message routing is automatically restored. (At "down" nodes using the 12771A and 12773A interfaces for the link, operator intervention will be required to re-enable the link.) Dynamic message rerouting can be omitted from network nodes that cannot take advantage of it, to minimize memory requirements.

Message accounting (DS/1000-IV to DS/1000-IV only)

In process control, order processing, stock re-ordering, and many other applications, it is critically important to assure that each message is received once and only once by the user level task to which it is directed. Optionally-usable DS/1000-IV subroutines provide this assurance by setting up an end-to-end protocol that both prevents duplication of messages and retransmits messages lost due to severe line failure. In addition, the message accounting function makes channel status information available to the user. Because it is optional, the message accounting function can be used selectively for only those channels that require maximum reliability, without incurring the additional memory requirements and CPU overhead for all nodes in the network.

Transaction logging and reporting

Transaction logging and reporting gives the user a powerful tool for analyzing and optimizing network traffic as well as isolation of communications link faults. With this facility enabled, all message request and reply buffers are logged on disc or magnetic tape. This includes transactions between the local DS/1000-IV node and remote nodes and/or a remote HP 3000 System. On request, the user can have the recorded information translated, edited, and reported in a format that facilitates analysis.

Remote I/O mapping and unattended network nodes

Remote I/O mapping can be used in DS/1000-IV networks to transparently map any local unit record device to another unit record device anywhere in the network. In this way, messages that would normally be exchanged with a local CRT terminal, printer, or mag tape unit can instead be exchanged with a similar device at another node. This can significantly reduce overall network hardware and programming costs and, along with the forced cold load capability of HP 1000 L, E, and F-Series Computers, enables unattended operation.

Remote Virtual Control Panel access to HP 1000 L-Series network nodes

DS/1000-IV includes two programs that work through the 12007A or 12044A L-Series HDLC interface in a neighboring L-Series network node to give an operator remote access to the Virtual Control Panel (VCP) program in that node. These programs in the accessing node provide control access to the VCP program and also monitor and display messages from the VCP program. With this capability, the remote operator can examine and change the contents of registers and memory locations, control the execution of diagnostics and other programs, and select a bootstrap loader and initiate the boot-up of the neighboring L-Series System. By making possible a considerable degree of remote fault diagnosis and maintenance, this remote VCP capability greatly enhances the supportability of completely unattended DS/1000-IV L-Series network nodes. It is important to understand, however, that remote VCP access cannot take advantage of the store-and-forward capability of the DS/1000-IV network. For that reason, remote VCP access can only be from neighboring DS/1000-IV network nodes.

DS/1000-IV capabilities

DS/1000-IV capabilities with respect to communication with other HP 1000 Systems and with HP 3000 Systems are summarized in Table 1, and discussed in the following paragraphs.

Remote command processing

DS/1000-IV to DS/1000-IV. DS/1000-IV remote command processing makes it possible for a user at a local terminal to interactively access any HP 1000 system in the DS/1000-IV network, via the nodal addressing and store-and-forward capabilities of DS/1000-IV. The local operator can use the entire RTE command set of the remote node as well as special network-oriented commands provided by the DS/1000 remote command processor, REMAT, which provide the capabilities tagged by R's in the DS/1000-IV to DS/1000-IV column of Table 1. A Network Security Code (NSC) is required to direct commands to a remote system, which protects the network from unauthorized access. Remote command processing is initiated as easily as:

```
RU,REMAT
$SW,N1,N2,NSC
```

This two-command sequence runs REMAT and directs subsequent RTE and/or REMAT commands to Node 1 (N1) or from Node 1 (N1) to Node 2 (N2). The accompanying Network Security Code (NSC) is always required to run REMAT, but not thereafter. By providing for Node 1 to Node 1 actions, DS/1000-IV remote command processing supports the direction of activities at unattended DS/1000-IV nodes.

HP 1000 virtual terminal to HP 3000. The operator at an HP 1000 system communicating with an HP 3000 system can execute local HP 3000 MPE commands. The HP 1000 system thereby becomes a virtual HP 3000 terminal, gaining access to facilities not available on the HP 1000, such as the COBOL compiler and QUERY/3000. Security is controlled by the requirement for an account (and, optionally, a password) in the HELLO sign-on command addressed to the HP 3000.

Table 1. 91750A Network communications capabilities

LEGEND:		
Y		= Yes, is supported by DS/1000-IV for this communications link.
N		= Not supported by DS/1000-IV for this communications link.
n/a		= Not applicable to this communications link.
R		= REMAT (DS/1000 Remote Command Processor) capability.
*		= Node 1 and/or Node 2 can be either local or remote.
<div style="display: flex; justify-content: space-between; align-items: center;"> <div style="text-align: left;"> <p>DS/1000-IV to DS/1000-IV</p> <p>DS/1000-IV to DS/3000</p> <p>DS/3000 to DS/1000-IV</p> </div> <div style="border: 1px solid black; padding: 2px;"> <p>Categories and descriptions of capabilities</p> </div> </div>		
REMOTE COMMANDS (Local operator's requests to local or remote DS/1000 nodes or HP 3000 System)		
Y	n/a	Y Local operator can issue any RTE system command to remote HP 1000 system. LU mapping now makes it possible to include running the file manager in this overall capability.
n/a	Y	n/a Local HP 1000 operator can issue MPE commands to remote HP 3000 system, including access to HP 3000 subsystems, such as Cobol and QUERY/3000.
R	Y	Y Attach or log on to remote account.
R	N	N Send a message to all other nodes.
R	N	N List mounted cartridges at node 1* on LU at node 2*.
R	N	N Create, close, purge, or rename file at node 1*.
R	N	N List file directory at node 1* on LU at node 2*.
R	N	N Dump a file or LU input from node 1* to LU at node 2*.
R	N	Y Terminate remote command processor.
R	N	N Display local node number and both local and remote session identification numbers.
R	N	N List file at node 1* on LU at node 2*.
R	Y	N Change local list or log device.
R	N	N Load absolute program from node 1* file or LU into node 2 RTE-L* or RTE-M* system.
R	N	N List all programs resident in RTE-M system or disc-based RTE-L system at node 1*.
R	N	N List all program-to-program "slave" programs at node 1*.
R	N	N Terminate a "slave" program at node 1*.
R	Y	N Store all records from a file or LU at node 1* to a file at node 2*.
R	N	N Transfer execution of subsequent commands to/from specified nodes.
R	Y	N Send message to operator at node 1*.
R	Y	N Transfer control of remote command processing to file or LU at a DS/1000 node.
REMOTE QUERY ACCESS TO IMAGE/1000 DATA BASE (Local operator's requests to QUERY at remote HP 1000 System)		
Y	N	N Give remote data base access name and select file name to remote QUERY.
Y	N	N Create procedure file at remote node for repetitive data base access operations.
Y	N	N Display previously-created QUERY procedure file.
Y	N	N Run interactive editor at remote node for editing procedure files, or run any other specified program.
Y	N	N Delete previously-created QUERY procedure at remote node.
Y	N	N Locate one or a group of data item names and/or data item.
Y	N	N Add, change, or delete a data item(s) that have been located in the remote data base by the QUERY find command.
Y	N	N Display or print out data item(s) that have been located in the QUERY data base by the find command.
Y	N	N List remote data base structure.
Y	N	N Explain form and purpose of specified types of QUERY commands or all QUERY commands.
Y	N	N Terminate remote QUERY execution.
Y	N	N Transfer command input to a file.
Y	N	N Change list device.

Table 1. 91750A Network communications capabilities, continued

DS/1000-IV to DS/1000-IV DS/1000-IV to DS/3000 DS/3000 to DS/1000-IV			Categories and descriptions of capabilities
			PROGRAM-TO-PROGRAM (PTOP) INTRINSICS (Program requests for communication between programs at local and remote HP 1000 and/or HP 3000 systems)
Y	Y	Y	From master program, initiate PTOp communications and schedule a slave program in the remote node, if necessary.
Y	Y	Y	Read data block from remote program and exchange tags.
Y	Y	Y	Send data block to remote program and exchange tags.
Y	Y	Y	Exchange user-defined tag field with remote slave program for user-defined control functions.
Y	Y	Y	Disconnect remote slave program from the master and initiate its termination.
Y	Y	Y	Get next request from the remote master program.
Y	Y	Y	Accept and complete master program's request.
Y	Y	Y	Reject master program's request.
Y	N	Y	From slave program, terminates communication with all master programs. Communication can be re-established by the master program by re-initiating PTOp.
			REMOTE DATA BASE ACCESS (RDBA) INTRINSICS (Program requests for access to data base in a remote HP 1000 system)
Y	N	N	Initiate access to data base.
Y	N	N	Get information on the organization and components of the data base.
Y	N	N	Locate master data set entry containing a specified key item value.
Y	N	N	Read data item values.
Y	N	N	Modify values of data in existing records.
Y	N	N	Add new records.
Y	N	N	Delete existing data records.
Y	N	N	Lock data base temporarily to provide exclusive access.
Y	N	N	Unlock previously locked data base.
Y	N	N	Close the data base files.
			REMOTE FILE ACCESS (RFA) INTRINSICS (Program requests for access to files in a remote HP 1000 or HP 3000 system)
Y	Y	Y	Create a file.
Y	Y	Y	Remove a file and directory entry.
Y	Y	Y	Open, close, or rename specified file.
Y	Y	Y	Transfer one record from a file (either sequential or direct access file on HP 3000).
n/a	Y	n/a	Read or write user's file label.
Y	Y	Y	Transfer one record to a file (sequential or direct access file on HP 3000).
Y	Y	N	Change file access mode.
Y	Y	N	Dynamically lock or unlock a file.
Y	Y	Y	Update record in a file.
Y	Y	Y	Position a file.
Y	Y	Y	Position file to a specified record.
Y	Y	N	Reset pointer for sequential file.
N	Y	N	Prepare for reading direct access file.
Y	n/a	Y	Send control request to peripheral device identified as type 0 file.
Y	Y	N	Control file or terminal device.
Y	Y	Y	Reset file to first record.
Y	Y	Y	Return file status.
N	Y	N	Request details on file I/O status.
Y	n/a	Y	Return status of mounted discs.
N	Y	N	Determine if file pair is interactive or duplicative.

Table 1. 91750A Network communications capabilities, continued

DS/1000-IV to DS/1000-IV DS/1000-IV to DS/3000 DS/3000 to DS/1000-IV			Categories and descriptions of capabilities
			REMOTE EXEC CALLS (DEXEC) (Program requests for action by executive in remote HP 1000 or HP 3000 system)
Y	n/a	Y	Read from or write to I/O device at remote system.
Y	n/a	Y	Control I/O device at remote system.
Y	n/a	N	Terminate remote program.
Y	n/a	N	Schedule remote program with or without wait.
Y	n/a	Y	Request time from system clock in remote system.
Y	n/a	Y	Set execution interval or start time of remote program.
Y	n/a	Y	Request status of remote system I/O device.
Y	n/a	N	Queue schedule remote program with wait.
Y	n/a	N	Queue schedule remote program without wait.
Y	n/a	N	Request partition status from remote system.
Y	n/a	N	Request remote program status.
			DS/1000 UTILITY CALLS (Network utility program requests)
Y	N	N	Send message to remote operator's console or to remote system's message processor.
Y	N	N	Obtain node number of local system.
Y	N	N	Down-load absolute program into remote RTE-L or RTE-M node.
Y	Y	N	Copy file from one node to another.
Y	N	N	Provide interactive access to RTE editor at remote disc-based node.
Y	N	N	Establish destination node for formatted FORTRAN I/O statements.
Y	N	N	Send command from program to remote command processor.
Y	N	N	Return information on DS/1000-IV errors.

Access to the HP 3000 from the HP 1000 is obtained by these three simple commands:

```
RU,REMOTE
$SW
HELLO (account)
```

HP 3000-to-DS/1000. An operator at an HP 3000 system using DS/3000 can execute any RTE operator command, which supports control of an unattended HP 1000 satellite system.

Remote data base access between HP 1000 Systems

Remote QUERY access now makes it possible for an operator at a memory-based or disc-based system to interactively access data in a 92069A IMAGE/1000 data base in a remote HP 1000 System operating under RTE-IVB. Remote access is essentially as easy as local access, since all command mnemonics and parameters are the same. The one exception is that the RU, QUERY request is issued from REMAT in the local system to the remote system and must include the node number of the local system.

Remote access from programs is accomplished with similar ease and can access both 92069A and 92073A data bases. All data base access calls, both local and remote, include an IBASE array parameter. The only difference between a local data base call and a remote one is that one of the words in the IBASE array in the DBOPN call for remote access contains the node number of the system whose data base is to be accessed. This provides total program transportability among systems in the DS/1000 network and supports network-wide data base data entry and retrieval with respect to one or several data bases.

Program-to-Program data exchange (PTOP)

Using high-level distributed system calls (Table 1), a Pascal, FORTRAN, or Assembly language program in a DS/1000-IV node can initiate a data exchange with a named Pascal, FORTRAN, or Assembly language program in a remote DS/1000-IV node or a FORTRAN or SPL program in a remote HP 3000 System. A program in the HP 3000 can also initiate the PTOp exchange.

Multiple PTOp exchanges can be active on the same network connection concurrently, and in DS/1000-IV nodes one program can communicate with more than one remote node concurrently. PTOp between DS/1000-IV nodes and to HP 3000 Systems supports data buffers up to 8k bytes long.

In addition to its use for exchanging data to be processed, the PTOp capability can be used to implement access by remote programs to IMAGE/3000 data bases. The records can be transferred to/from the remote requesting program, using PTOp intrinsics.

Remote file access

High-level DS/1000-IV calls analogous to standard RTE-FMP or FS/3000 calls can be used by Pascal/FORTRAN/Assembly language programs in HP 1000 Systems and FORTRAN/SPL programs in HP 3000 Systems to define, access, control, and query the status of named files in a remote DS/1000 node or HP 3000 System. This capability facilitates the establishment, maintenance, and use of distributed data files using the intrinsics described in Table 1. Remote file access between DS/1000-IV nodes now supports transfers of very large files, with up to 2^{31} logical records.

Remote calls to the RTE system executive

Pascal/FORTRAN/Assembly language programs in an DS/1000-IV node or FORTRAN/SPL programs in an HP 3000 System can make calls to the system executive in a remote DS/1000-IV node to write to, read from, control, or get status of I/O devices. Other calls can be used to request partition and/or program status, schedule programs with or without wait, request system clock time, and to set execution interval or start time of a program. A single DS/1000-IV node can concurrently service multiple system executive request calls which are listed in Table 1.

Remote FORTRAN read/write (DS/1000-IV to DS/1000-IV only)

The FORTRAN IV/4X formatter for RTE systems, working with DS/1000-IV subroutine RMTIO, supports locally programmed FORTRAN read/write statements to read from or write to any logical unit (LU) specified peripheral device at any specified remote node with programming as simple as:

```
C WRITE A MESSAGE ON LU6 AT NODE 21
  CALL DNODE(21)
  WRITE(6,10)
10 FORMAT("DS/1000 SUPPORTS REMOTE FORTRAN I/O")
```

With LU mapping set up, remote FORTRAN read/write is even simpler, since the DNODE call is not necessary.

Remote DS/1000-IV node system generation

Operating systems for RTE-L, RTE-IVB, or RTE-M based DS/1000-IV nodes can be generated at a single RTE-L or RTE-IVB based DS/1000-IV node and copies distributed using REMAT and loaded locally. RTE-L and RTE-M systems can also be generated elsewhere and loaded directly into neighboring RTE-L or RTE-M based nodes from RTE-IVB based DS/1000-IV nodes using the built-in DS loader on the L-Series processor in the RTE-L based system or the Communications Bootstrap Loader in the RTE-M based system.

It is most convenient to generate all systems at one RTE-IVB based node and send system files through the network to the node in which they will reside. The same gen file can be sent to several RTE-IVB nodes at which each would be switched and slow booted for the appropriate memory and I/O configuration. With disc-based RTE-L nodes, the gen file can be sent to the system disc using REMAT and later loaded from the local file. For RTE-MIII nodes and memory based RTE-L nodes, the gen file can be sent to a neighboring disc-based node and stored in a file on the disc there for later loading into the memory-based node.

Remote DS/1000-IV node program development

Program development for an entire DS/1000-IV network of HP 1000 systems can be accomplished at a single DS/1000-IV node. At an RTE-L or RTE-M node, programs for other DS/1000-IV nodes can be developed on-line, relocated off-line, and loaded on-line into other RTE-L or RTE-M nodes by operator command or program call. If necessary, these programs can be relocated into RTE-IVB nodes by operator command. At an RTE-IVB node, programs can be developed and relocated on-line and loaded into any target RTE-L or RTE-M node using an operator command or program call. Programs can also be relocated into any target RTE-IVB node by operator command.

Network utilities (DS/1000-IV to DS/1000-IV)

Network utilities provide single-call programming for such network tasks as sending messages to remote DS/1000-IV nodes, retrieving local node numbers, copying files from any DS/1000-IV node to any other DS/1000-IV node, and retrieving any DS execution errors. The interactive RTE Editor can be run at remote RTE-IVB nodes. These capabilities make the network manager's and application programmer's jobs easier.

Remote sessions under RTE-IVB

Remote access to a DS/1000-IV node operating under RTE-IVB and Session Monitor is under the same control as a local session at that node. Session Monitor access control requires all users, including remote users, to log on under a pre-defined user name that has been given specific capabilities by the system manager. All RFA, DEXEC, PTOp, and operator command access to a remote RTE-IVB/Session Monitor node thus requires a prior log-on. This is accomplished in one of the following ways:

1. Utility program DLGON that creates a specific remote, non-interactive session, or
2. REMAT "ATTACH" command, or
3. REMAT "SWITCH" command, with a user-name qualifier appended to the requested node number, or
4. HP 3000 REMOTE HELLO command, or
5. No specific assignment request; if no specific session log-on has been issued, the system will set up a session for the default user name that was specified during network initialization.

Once logged on, each user is assigned a unique session ID, which is that user's key to access the remote node. A user can have a session at any of up to 16 different HP 1000 nodes, but only one remote session is supported per node. Sessions are non-interactive in the sense that remote session (FMGR) commands to the remote node are not supported. However, REMAT commands are supported and can be used to remotely perform various program development and program testing tasks, or to remotely run applications. Because remote session commands are not supported, and because there is no REMAT-type support in the HP 3000 environment, HP 3000 virtual terminal access to a remote HP 1000 session is not supported.

All accessed files must reside on an existing and mounted private, group, or system disc cartridge. "System discs" also include session monitor global discs, which can be read/written by any user in the system.

A default account can be set up for use by all requesting nodes that do not explicitly log on. "Old" nodes (those using 91740A/B DS/1000 Network software-firmware) will be assigned to a single shared default session, which, once created, will be permanently active. Old node shared access to this session will appear to the user as a non-session monitor system.

DS/1000-IV to DS/1000-IV network description

Layered architecture

The DS/1000-IV software and hardware for DS/1000-IV to DS/1000-IV connections in each system, or network node, consists of several layers, as shown in Figure 2. The Network Service Intrinsic are called by the user's application programs or operator commands to generate the transaction format for master requests to remote nodes, with data as required. The master requests generated are those for PTO, RFA, DEXEC, Remote operator command, and utility program capabilities described in Table 1.

The Network Interface Monitors process incoming master requests received from Communications Management software (CM/1000) and link them as required to user's slave PTO programs, file management routines or the RTE EXEC. The CM/1000 layer routes network transactions, queues them, and manages the local system resources necessary for network communications. CM/1000 also manages the store-and-forward operations, and dynamic message re-routing and message accounting if these optional capabilities are used.

The CM/1000 layer communicates with the link-level software drivers, which in turn communicate with the interface hardware, which may be several hardwired and/or modem interface cards, via the Communications Access Method (CAM) firmware. The CAM firmware is located in the computer's control store for use with the older 12771A/12773A interfaces, and in the interface control store on the new 12007A, 12044A, 12794A, and 12825A HDLC interfaces. The CAM firmware provides a line protocol for the control of communications input and output, including error detection and correction by retransmission. The lower layers are managed such as to be completely transparent to the user. Changes to these layers of the network can be made with little or no effect on user's application programs.

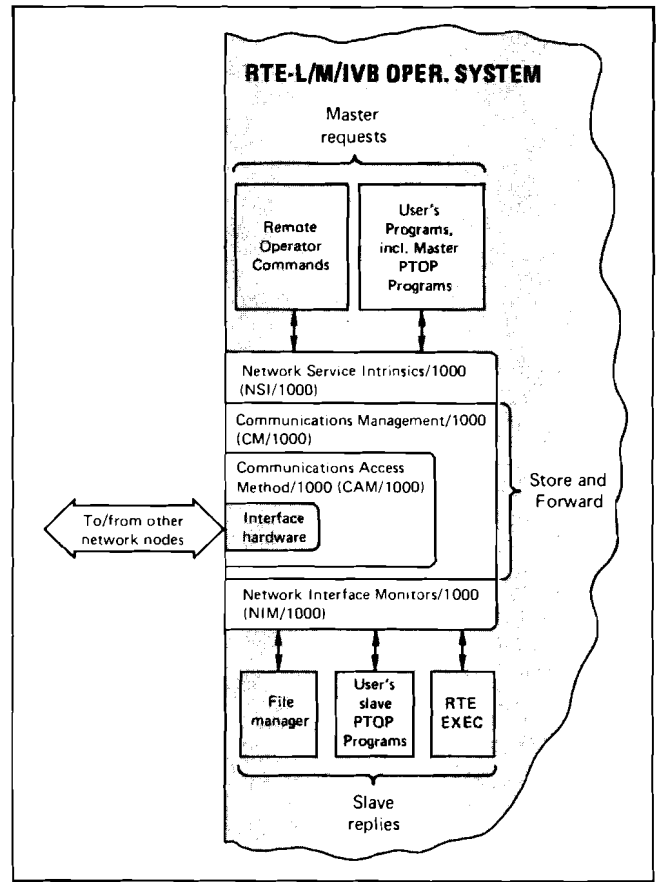

Figure 2. DS/1000 Layered Network Communications Architecture

Modular software supports three levels of DS/1000-IV node capability

Another advantage of Hewlett-Packard's layered approach to network communications software and firmware is its modularity, modularity that accommodates three main levels of network capability with many gradations in between.

RTE-L nodes are low-cost, memory or disc-based systems intended for dedicated use in measurement and control or automatic test applications. This configuration supports DS/1000-IV to DS/1000-IV communication, including remote access to data bases in RTE-IVB based network nodes; however, DS/1000-IV to HP 3000 is not supported.

Mapped RTE-M nodes are memory based systems whose larger memory capacity (128k to 2.048 million bytes) give them far more configuration flexibility than RTE-L nodes. This configuration can support both DS/1000-IV to DS/1000-IV and DS/1000-IV to HP 3000 communication. These nodes can also provide local flexible disc based program development and off-line system generation capabilities as well as local program and data files accessed from multiple terminals. These extra capabilities are in addition to the ability to perform multiple tasks similar to those of the RTE-L node. RTE-M program calls are compatible with RTE-IVB, which facilitates upgrading.

RTE-IVB nodes are the most capable of all. They require 128k bytes of memory, expandable to 2.048 million bytes, and at least 19.6 million bytes of disc memory (up to 960 million bytes can be provided). Because of their large main and disc memory capacities, RTE-IVB nodes can provide network-wide support for HP 1000 system generation and program development, high speed computation and data file facilities to other nodes operating under RTE-L, RTE-M or RTE-IVB. The RTE-IVB node can support all DS/1000-IV capabilities, including DS/1000-IV to HP 3000 communications as well as communications with other DS/1000-IV network nodes.

Transaction request buffering

The Network Interface Monitors in DS/1000-IV (for PTOP, RFA, RDBA, remote operator command, remote I/O, and remote program scheduling functions) interface to CM/1000 communications management processors via complete requests and replies with data buffers as required. Therefore, the Network Interface Monitors can service multiple requests or replies concurrently, though working on only one request at a time. The monitors themselves can be swapped in RTE-IVB while the system performs the data transfer, thereby freeing up memory for other programs or tasks.

DS/1000-IV architecture for DS/1000-IV to HP 3000 communication

DS/1000-IV software for DS/1000-IV to HP 3000 communications is layered similarly to Figure 2. The important differences appear in the bottom two layers. The CM/1000 layer includes translators for conversion of DS/1000-IV requests and replies to/from DS/3000 format. CM/1000 software is designed to work with only one remote HP 3000 system and does not provide for nodal addressing or store-and-forward operation to/from the HP 3000. Communications Access Method functions are performed by a software-only synchronous line controller with the 12889A Hardwired Serial Interface or by CAM firmware on the microprocessor-controlled 12793A Bisync Modem Interface.

Communications facilities

As shown in Figure 3, DS/1000-IV communications, whether between DS/1000-IV network nodes or between a DS/1000-IV node and an HP 3000 System can take place via either direct connect or modem links. For hardware data rates of the respective DS/1000-IV interfaces, see their data sheets in this data book.

Efficient error control

HP 1000-to-HP 1000 communication via HDLC interfaces

On both the direct connect and modem HDLC interfaces, CRC-16 cyclic redundancy checking detects errors, and the interface retransmits all frames sent or received in error. This maximizes transmission accuracy while only rarely requiring intervention by the CPUs at the respective DS/1000-IV network nodes.

HP 1000-to-HP 1000 communication via 12771A/12773A interfaces

The 12771A and 12773A interfaces use LRC/VRC/DRC (longitudinal, vertical, and diagonal redundancy checking) for error detection. Longitudinal parity is checked by the interface card at the receiving node. Vertical and diagonal parity words are generated by the microcoded CAM/1000 drivers (DS/1000 firmware), which must be installed in the control store of the computers in the transmitting and receiving nodes. The receiving node returns its parity words to the transmitter for comparison. A parity word mismatch causes retransmission of the block. Because error control is accomplished mostly by HP 1000 microcode in the control store of the computer, system overhead is kept low, though not as low as with the HDLC interfaces.

HP 1000-to-HP 3000 communication

Both direct-connect and modem communications between HP 1000 and HP 3000 systems are monitored for errors by CRC-16 cyclic redundancy checking on all blocks sent or received. Error detection is implemented in hardware on the 12889A and 12793A interfaces. Detection of an error results in a request for retransmission. The 12793A interface automatically responds to retransmission requests from the HP 3000, thereby minimizing error control overhead at the HP 1000 System.

Functional specifications

Network capacity and performance

Usable transfer rates and the maximum number of star-connected nodes that can be serviced by a central node are complex functions of the following factors:

- The type and speed of communications links in use.
- The way in which a user's application program uses a particular type of DS/1000-IV Network Service Intrinsic, such as PTOP or RFA.
- The processing time required by the DS/1000-IV software and the user's application in a particular HP 1000 Computer.
- The resources, such as System Available Memory, available in the computer at each node.
- The impact on system resources of local activity that must also be supported at the nodes.

Because of the complexity of the interrelationships of these factors, Network capacity and performance are discussed in a separate DS/1000-IV Performance Brief, which is available from your Hewlett-Packard representative.

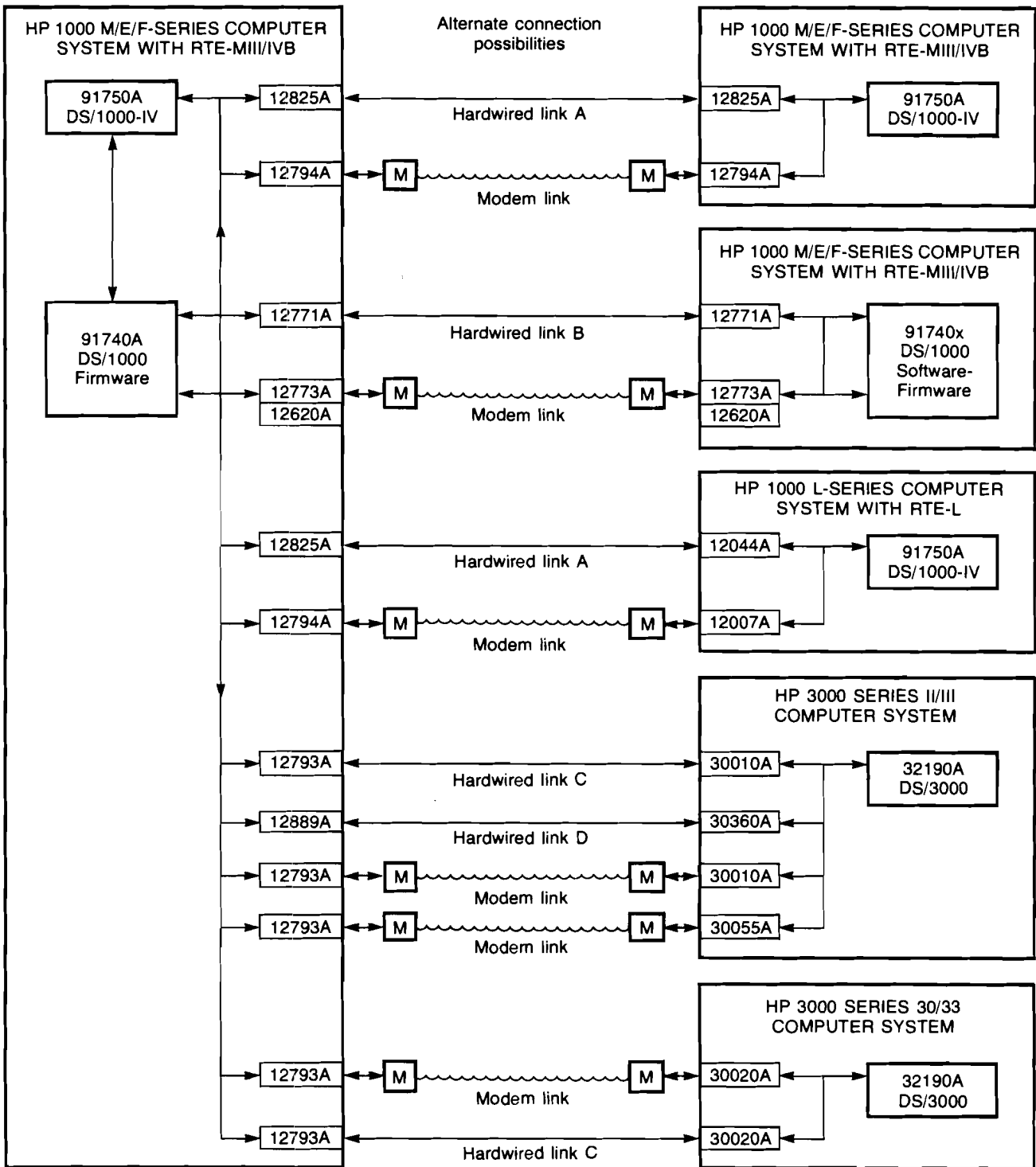

Hardwired link A: Maximum cable length 2.2km/7218ft; interface options may be ordered to obtain 75m/255ft extension cable and 300m/984ft user-assembled cable kit.

Hardwired link B: Maximum cable length 3km/10000ft; communications cable extension may be ordered as a 91720A cable kit with unassembled connectors or as 91721A cable with assembled connectors with 76m/250ft std length, 152m/500ft option 001 length, or 297m/975ft option 002 length.

Hardwired link C: Maximum cable length 15.2m/50ft; must be provided by 30225A Modem eliminator cable to 30010A or 30225B Modem eliminator cable to 30020A.

Hardwired link D: Maximum cable length 609m/2000ft; must be provided by 30220A Coaxial cable kit, available in lengths from 7.6m/25ft to 609m/2000ft.

Figure 3. DS/1000-IV Network connections

Configuration information

System compatibility

See Table 2.

Table 2. 91750A DS/1000-IV System Compatibility

Computers	Systems	Operating Systems	Interfaces	Remote System
2103L 2108M, 2109E, 2111F, 2112M, 2113E & 2117F	2146A/B 2174A/B 2175A/B 2176C/D 2177C/D	92070A RTE-L 92068A RTE-IVB and 92064A RTE-M (MII or MIII configuration)	12007A & 12044A 12794A & 12825A	Any HP 1000 L/M/E/F-Series System using 91750A soft- ware and appropriate interface*
2108M, 2109E, 2111F, 2112M, 2113E & 2117F	2174A/B 2175A/B 2176C/D 2177C/D	92068A RTE-IVB and 92064A RTE-M (MIII config)	12771A & 12773A NOTE A	HP 1000 M/E/F- Series System using 91740A/B software-firm- ware and appropriate interface*
2108M, 2109E, 2111F, 2112M, 2113E & 2117F	2174A/B 2175A/B 2176C/D 2177C/D	92068A RTE-IVB and 92064A RTE-M (MIII config)	12793A & 12889A	HP 3000 Series II/III/30/33 System and appropriate interface*

* Appropriate interface means that interface in remote system must match communication mode and protocol (direct connect or modem and WASP or HDLC) of interface in local system. For appropriate counterpart interfaces, see Figure 3.

NOTE A: 91740A/B/PIR DS/1000 firmware is required with 12771A and/or 12773A interface(s) used in a DS/1000-IV node. With the 12773A Modem interface, a 12620A Breadboard interface used as a privileged interrupt control card is also required.

Compatibility with other active HP network products

91750A DS/1000-IV Network software is compatible with 32190A DS/3000 software in HP 3000 Series II/III/30/33 Systems and the 91780A RJE/1000 IBM 360/370 Remote Job Entry package.

Backward compatibility with "old" DS/1000 network nodes

The 91750A DS/1000-IV Network software is backward compatible with 91740A/B (inactive) Network software-firmware at "old" DS/1000 network nodes. All DS/1000 features supported between 91740A/B nodes are supported between a 91750A node and a 91740A/B node, but some new DS/1000-IV features, such as Dynamic Message Rerouting and direct communication between HP 1000 L-Series and M/E/F-Series computers, are not supported. In addition, communication between a 91750A node and a 91740A/B node must use 12771A direct connect interfaces or 12773A modem interfaces in both nodes. In the 91750A node, 91740A/B DS/1000 firmware must be provided to support communication via the 12771A/12773A interface. When the 12773A interface is used, a 12620A Breadboard interface must be provided in each node as a privileged interrupt control card.

System requirements

NOTE: Refer to latest HP 1000 Ordering Information (August 1, 1980 or later) for details on terminal interface cable options and other configuration details.

Unattended HP 1000 L-Series DS/1000-IV Network node:

- 2103L Computer (includes 64kb memory) or 2103LK Computer with 12030A or 12032A Card Cage and 12035A Power Module or user-furnished power supply.
- 12013A Battery Backup Module (or user-fabricated memory backup provision).
- RTE-L real-time executive operating system with DS/1000-IV network software, which may be generated remotely and down-loaded to the using node.
- 12007A (modem) or 12044A (direct connect) HDLC interface with appropriate modems and phone lines or direct connect cables for each connection to a DS/1000-IV network node.
- Application-related items required at the unattended node.

NOTE: A 2146A/B System Processing Unit could be used instead of items 1 and 2, but it provides more hardware than is required for an unattended network node.

Attended HP 1000 L-Series DS/1000-IV Network node:

- 2146A/B System Processing Unit or one of the computer choices with battery backup module listed as items 1 and 2 of the unattended L-Series network node.
- 12005A Asynchronous Serial (terminal) interface (included in 2146A/B System Processing Unit and therefore not required separately if 2146A/B is used as item 1).
- 12009A HP-IB disc interface (included in 2146A/B System Processing Unit and therefore not required separately if 2146A/B is used as item 1).
- RTE-L real-time executive operating system with DS/1000-IV network software, which may be generated remotely and down-loaded to the using node. (RTE-L is included in 2146A/B System Processing Unit and therefore is not required separately if 2146A/B is used as item 1.)
- 2621A/P, 2635A/B, or 264x Terminal as system console.
- 7910HR Fixed disc or 7906H Cartridge ICD drive (optional system disc).
- 12007A (modem) or 12044A (direct connect) HDLC interface with appropriate modems and phone lines or direct connect cables for each connection to a DS/1000-IV network node.
- Application-related items required at the attended node.

Unattended RTE-M based HP 1000 E/F-Series DS/1000-IV Network node:

- One of the following computers:
 - 2109E +014 Computer and 128kb or more standard performance or high performance memory, with or without fault control (12786x/7x/8x/9x), or
 - 2111F +014 Computer and 128kb or more high performance memory, with or without fault control, (12788x/9x), or
 - 2113E Computer (includes 128kb standard performance memory), or d. 2117F Computer (includes 128kb high performance memory).
- 12539C Time Base Generator.
- 12944B (with 2109E) or 12991B (with 2111F/2113E/2117F) Power Fail Recovery System.
- RTE-M operating system with DS/1000-IV network software, which may be generated remotely and down-loaded to the using node.

5. 12794A (modem) or 12825A (direct connect) HDLC interface with appropriate modems and phone lines or direct connect cables for each connection to a DS/1000-IV network node. (12771A direct connect interface or 12773A modem interface with 12620A interface could be used along with 91740B/R firmware if remote forced cold load is not required).
6. Application-related items required at the unattended node.

Attended RTE-M based HP 1000 E/F-Series DS/1000-IV Network node:

1. Items 1 through 4 of the unattended RTE-M node, above, or one of the following systems:
 - a. 2174A/B+014 Computer System with 128kb or more standard or high performance memory, with or without fault control (12786x/7x/8x/9x), or
 - b. 2175A/B+014 Computer System with 128kb or more high performance memory, with or without fault control (12788x/9x).
2. 264x System Console (included in 2174A/B and 2175A/B System and therefore not required separately if 2174A/B or 2175A/B is used as item 1).
3. 12794A (modem) or 12825A (direct connect) HDLC interface with appropriate modems and phone lines or direct connect cables for each connection to a DS/1000-IV network node.
4. 12793A (modem) or 12889A (direct connect) Bisync interface with appropriate modems and phone line or direct connect cables for connection to HP 3000 system.
5. 12773A (modem) or 12771A (direct connect) interface with appropriate modems and phone line or direct connect cable for each connection to an "old" DS/1000 network node. 91740B/R DS/1000 firmware is required for use of 12773A and/or 12771A interfaces and a 12620A Breadboard interface is required for privileged interrupt control if a 12773A interface is used.
6. Application-related items required at the attended node.

Attended RTE-IVB based HP 1000 E/F-Series DS/1000-IV Network node:

1. Items 1 through 3 of the unattended RTE-M node, above, or one of the following systems:
 - a. 2176C/D+019 Computer System (includes 128kb standard performance memory), or
 - b. 2177C/D+019 Computer System (includes 128kb high performance memory).
2. 12897B Dual Channel Port Controller (included in 217xC/D system and therefore not required separately if 217xC/D is used as item 1).
3. 264x System Console.
4. Any 79xxH/HR ICD disc (except 7910H/HR) and 12821A ICD interface to computer or any 79xxM/MR MAC Master disc and 13175B MAC disc interface to computer.
5. RTE-IVB operating system with DS/1000-IV network software, which may be generated remotely and downloaded to the using node. (RTE-IVB is included in 217xC/D System and therefore is not required separately if 217xC/D is used as item 1).
6. 12794A (modem) or 12825A (direct connect) HDLC interface with appropriate modems and phone lines or direct connect cables for each connection to a DS/1000-IV network node.
7. 12793A (modem) or 12889A (direct connect) Bisync interface with appropriate modems and phone line or direct connect cables for connection to HP 3000 system.

8. 12773A (modem) or 12771A (direct connect) interface with appropriate modems and phone line or direct connect cable for each connection to an "old" DS/1000 network node. 91740B/R DS/1000 firmware is required for use of 12773A and/or 12771A interfaces and a 12620A Breadboard interface is required for privileged interrupt control if a 12773A interface is used.
9. Application-related items required at the attended node.

Attended RTE-M or RTE-IVB based HP 1000 M-Series DS/1000-IV Network Nodes: HP 1000 M-Series Network Nodes are similar to HP 1000 E/F-Series Network Nodes, summarized above, except that computer product numbers are:

- 2108M+014 Computer with 128kb or more memory with or without fault control (12784x/5x), using 12944B Power Fail Recovery System, or
- 2112M Computer (includes 128kb memory), using 12991B Power Fail Recovery System.

And that 91740A/P DS/1000 firmware is required to support communication with "old" DS/1000 network nodes.

Operating system and DS/1000-IV software for DS/1000-IV network nodes

The operating system (92068A RTE-IVB, 92070A RTE-L, and/or 92064A RTE-M) software and 91750A DS/1000-IV network software must be purchased for the first network node. Systems generated from this software may then be copied to additional network nodes provided that the customer has purchased an appropriate right to copy product (92068R, 92070R or 92070E, and 91750R) for each additional node supported. Purchase of an operating system included in a 214x or 217x system product does not qualify the customer to purchase a right to copy that operating system. The 92064A RTE-M operating system can be copied to additional network nodes without purchase of a right to copy product.

Requirements for remote data base access

The remote data base to be accessed must be managed by the 92069A or 92073A IMAGE/1000 Data Base Management System operating under the 92068A RTE-IVB real-time executive system. The 92073A IMAGE/1000 Data Base Management System does not support remote QUERY access.

Memory requirements

For RTE-L based node: The RTE-L operating system and minimum required DS/1000-IV programs use about 44k bytes of memory, leaving about 18k bytes for addition of PTOP, DEXEC, or remote session access capabilities and user's application programs. Because maximum memory supported under RTE-L is 64k bytes, the remote response capabilities supportable at an RTE-L based node are relatively limited. However, the level of capability that is available is generally adequate for a dedicated node that functions mainly as a satellite to one or more RTE-IVB based DS/1000-IV network nodes.

For RTE-MIII based node: The RTE-MIII operating system and minimum required DS/1000-IV programs use about 47k bytes of memory (about 58k bytes with re-routing, message accounting, and remote session access capabilities). In a node with 128k bytes, this leaves about 68k to 79k bytes for addition of optional capabilities (PTOP, DEXEC, RFA, etc.) and user's application programs. If optional capabilities are to be extensive, and particularly if they are to include DS/1000 to DS/3000 communication, it is desirable to provide 256k bytes of memory in the RTE-MIII based node.



For RTE-IVB based node: The RTE-IVB operating system and minimum required DS/1000-IV programs use about 84k bytes of memory (94k bytes with re-routing and message accounting). Because an RTE-IVB based node will usually support most, if not all, of the optional capabilities of DS/1000-IV, at least 256k bytes of memory, and preferably 384k or 512k bytes, should be provided so that a reasonable number of DS/1000-IV capabilities can reside in their partitions at the same time. This minimizes swapping and assures fastest possible network response. Of course, addition of non-DS capabilities with large memory requirements, such as Pascal/1000 or DATACAP/1000-II, would necessarily require even more memory.

Responsibilities of the customer

The DS/1000-IV user must assume the following responsibilities with the purchase of 91750A DS/1000-IV Network software:

1. Installation of communication facilities (cables and/or modems) and their connection to the HP 1000 Computer Systems equipped with DS/1000-IV. The establishment of successful communication between HP 1000 Computer Systems equipped with DS/1000-IV is the customer's responsibility.
2. One person in the customer's organization must be designated as the Network Manager. This person will assume responsibility for configuration and generation of the customer's systems and will function as the focal point for Hewlett-Packard's support of the network. This person must be knowledgeable in HP's RTE operating system and must have taken the DS/1000-IV User's and Theory of Operation Courses.
3. DS/1000-IV software is a customer-installed product unless it is ordered with an HP 1000 System.
4. Hewlett-Packard strongly recommends that the customer purchase Customer Support Service or Software Subscription Service for DS/1000-IV and related hardware and software support products.

Ordering information

91750A DS/1000-IV Network Software

The 91750A DS/1000-IV Network Software includes:

1. One of software media options 020, 041, 050, or 051, which must be ordered.
2. 91750-80001 Communications Bootstrap Loader (CBL) ROM.
3. 91750-90001 DS/1000-IV Software Numbering Catalog.
4. 91750-90002 DS/1000-IV User's Manual.
5. 91750-90003 DS/1000-IV Network Manager's Manual.
6. 91750-90004 Getting Started with DS/1000-IV.
7. 91750-90005 DS/1000-IV Quick Reference Guide.
8. 91750-90006 DS/1000-IV Communications Bootstrap Loader ROM Installation Manual.

91750A Options

- 001: Provides discount for upgrade from 91740A/B or previous revision of 91750A to latest revision for customers without 91740T/S or 91750T/S.
- 002: Provides discount for upgrade from 91740A/B to 91750A for customers with 91740T/S support service.
- 020: Provides DS/1000-IV software on Mini cartridges.
- 041: Provides DS/1000-IV software on double-density, double-sided flexible disc for L-Series.
- 050: Provides DS/1000-IV software on 800 bpi, 9-track magnetic tape.
- 051: Provides DS/1000-IV software on 1600 bpi, 9-track magnetic tape.

91750R Right to Copy DS/1000-IV software for use on an additional Computer System

The 91750R Right to copy product is available only to customers who have purchased a license to use 91750A. 91750R consists of:

1. The right to make one copy of software purchased with the 91750A DS/1000-IV Network software product for use on an additional system.
- 2-8. Same as items 2 through 8 of 91750A, above.

91750R Options

- 001: Discount for right to copy 91750A+001 product or 91750T/S updates for customer who has previously purchased 91750R product.
- 002: Discount for right to copy 91750A+002 product for customer on 91740T/S software support service who has previously purchased 91740P/R product.

Software support products available

91750T Customer Support Service for 91750A Software (same media option as 91750A)

91750V Central Support for additional copy of 91750A

91750S Software Subscription Service for 91750A Software (same media option as 91750A)

91750W Right to copy 91750S updates once

91750Q Manual update service for 91750A software manuals.

91750T/V/S/W Interface firmware update options

- 101: Firmware update support for one HDLC interface.
- 102: Firmware update support for two HDLC interfaces.
- 104: Firmware update support for four HDLC interfaces.
- 108: Firmware update support for eight HDLC interfaces.
- 201: Firmware update support for one Bisync interface.
- 202: Firmware update support for two Bisync interfaces.
- 204: Firmware update support for four Bisync interfaces.
- 208: Firmware update support for eight Bisync interfaces.



**HEWLETT
PACKARD**

HP 1000 L-Series and M/E/F-Series HDLC Network Interfaces for DS/1000-IV communication between HP 1000 Systems

product numbers 12007A, 12044A, 12794A, and 12825A

The 12007A, 12044A, 12794A, and 12825A are interfaces for modem or direct connect communication between DS/1000-IV network nodes based on both HP 1000 L-Series and M/E/F-Series Computers. Series applicability of these interfaces is summarized in Table 1, below. All of these microprocessor-based interfaces use the widely-accepted, full-duplex High Level Data Link Control (HDLC) protocol to maximize communications efficiency and reliability. The interface handles all HDLC protocol generation, including CRC-16 error checking, on-board buffer management, and all modem control tasks (12007A and 12794A interfaces only). In conjunction with 91750A DS/1000-IV software, the HDLC interfaces support high-level user access between HP 1000 computers.

Table 1. Series applicability of HDLC Network Interfaces

Type of Interface	For HP 1000 L-Series Use	For HP 1000 M/E/F-Series Use
Modem	12007A	12794A
Direct Connect	12044A	12825A

Features

- Availability of both modem and direct connect interfaces to maximize network planning flexibility
- On-board microprocessor off-loads the computer, making possible larger networks and leaving more CPU capacity for processing user's applications
- 16k bytes of RAM memory for extensive on-board message buffering
- Firmware-controlled automatic power-up self test to help assure interface integrity
- Long term communication line statistics and message logs are available through user request via DS/1000-IV software to facilitate checks of line quality and assist link troubleshooting
- HDLC interface for DS/1000-IV to DS/1000-IV communication links with microprocessor management of HDLC protocol, CRC-16 error checking, buffer management, DMA transfers, and modem control tasks
- Data rates to 257k bps
- Supports remote Forced Cold Load (FCL) over DS/1000-IV links
- Supports remote Virtual Control Panel access to L-Series DS/1000-IV network nodes
- 12007A and 12794A support synchronous full duplex modems
- 12044A and 12825A interfaces support hardwired links up to 2.2km/1.36mi
- 12044A/12825A optically isolated input breaks ground loops, maximizing noise immunity for direct connect links

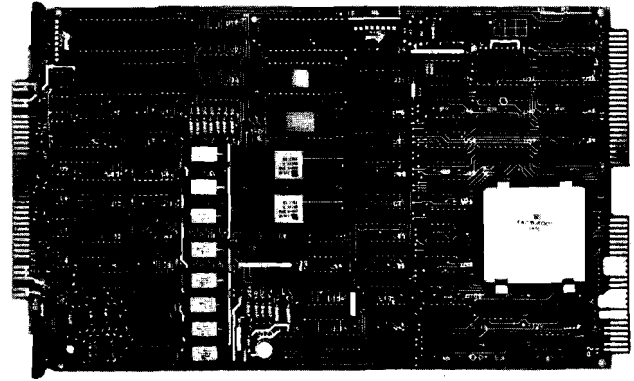

12007A L-Series HDLC Modem Interface (12044A L-Series HDLC Direct Connect Interface is similar)

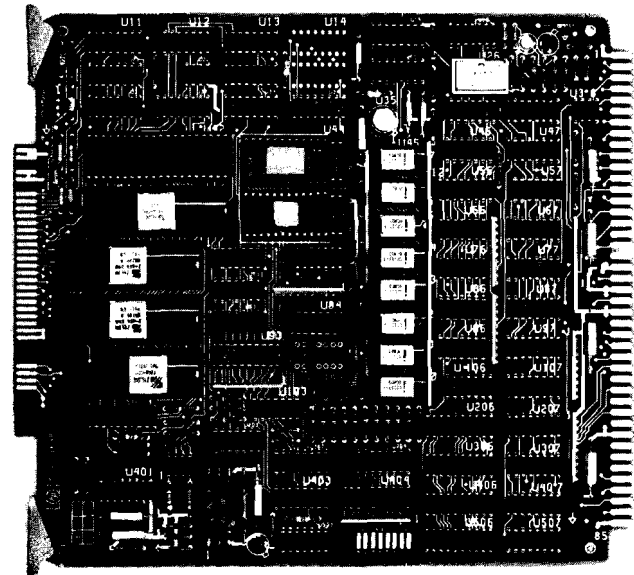

12825A M/E/F-Series HDLC Direct Connect Interface (12794A M/E/F-Series HDLC Modem Interface is similar)

Functional description

On-board microprocessor off-loads host computer

A powerful microprocessor on the HDLC network interface manages routine communications processing, freeing the host computer for applications oriented tasks. Under control of on-board firmware, the microprocessor converts command words into actions, such as establishing the communications link and loading/unloading data from the on-board buffers to the host CPU. The microprocessor also performs the protocol generation and interpretation, error

checking, and error recovery by retransmission, all without the attention of the host computer.

Numerous user-programmable parameters are available to tailor the interface to specific applications and configurations, which are also managed by the microprocessor. For example, the number of retransmissions of frames in error can be set by the user, or a default of 10 may be used. Frame size is accessible, as are controllable communications line timeouts to promote maximum use and efficiency of the communications links.

Interface buffer tasks, also microprocessor managed, include packing bytes into words for Direct Memory Access transfers to the host CPU and unpacking words into bytes for transmission.

Finally, on the 12007A/12794A interface, the microprocessor handles the synchronous modem control signals and is capable of setting additional modem control lines, such as Rate Select.

Firmware controlled self tests

On-board, firmware-controlled self tests, performed at power-up, help to assure reliable operation of the HDLC network interface and minimize troubleshooting time. These tests check out the RAM and ROM memories, the Direct Memory Access operations, baud rate generators, and the I/O parts of the communication interface.

Communications line statistics

Eleven long-term statistics are accumulated automatically and buffered on the interface. These statistics can be easily read by the user to help determine the quality of the communication line and to aid link troubleshooting. All statistics are cleared when read, facilitating use, since they are 16-bit unsigned integers (0-65535) that will roll over if not cleared or reset. The eleven long-term statistics are:

1. Information frames correctly received.
2. Receiver Ready frames received.
3. Receiver Not Ready frames received.
4. Reject frames received.
5. Receive process overruns.
6. CRC errors.
7. Abort sequences received.
8. SIO chip receiver overruns.
9. Receive buffer overruns.
10. Frames with incorrect address field.
11. CMDR frames received.

Remote Forced Cold Load capability

The HDLC network interfaces support Remote Forced Cold Load (FCL) in which a remote HP 1000 L/E/F-Series Computer is forced to accept and run a new program load regardless of its current state. In this way, the HDLC interfaces and the 91750A software provide a capability that supports completely unattended remote DS/1000 nodes.

Remote L-Series Virtual Control Panel capability

The 12007A and 12044A interfaces can be set to support Virtual Control Panel (VCP) access to an HP 1000 L-Series System from the system console at any remote but adjacent HP 1000 L/M/E/F-Series System in the same network. With VCP capability, an operator at the remote console can examine and change the contents of registers and memory locations, control execution of diagnostics and other programs, and select a bootstrap loader and initiate the boot-up of the L-Series System. By making possible a considerable degree of remote fault diagnosis and maintenance, this VCP

capability greatly augments the support for completely unattended DS/1000 L-Series nodes.

Functional specifications

Communications

Interface level: EIA RS-232-C and EIA RS-449.

Internally-clocked, programmable data rates: 300, 1200, 2400, 4800, 9600, 19200, 57600, and 230000 bits/second.

Externally-clocked data rates: To 257000 bits/second.

Usable 12044A/12825A Data Rates and Direct Connect Cable Length: Usable direct connect data rate depends on the length of the cable used for data transfer, as follows:

Data Rate to	Cable Length
257,000 bps	1km/0.6214mi/3281ft
57,600 bps	2.2km/1.367mi/7218ft

12007A/12794A Interface signals:

Signal	Source	Default	Function
RD	DCE	None	Receive data
SD	DTE	None	Send data
CS	DCE	DCE dep	Clear to send
RS	DTE	F/W	Request to send
TR	DTE	F/W	Data terminal ready
RR	DCE	DCE dep	Receiver ready (Data carrier detect)
ST	DCE	None	Send timing (Transmit clock)
RT	DCE	None	Receive timing (Receive clock)
TT	DTE	None	Terminal timing
IC	DCE	DCE dep	Incoming call (Ring indicator)
DM	DCE	DCE dep	Data set ready
TM	DTE	DCE dep	Test mode
LL	DTE	F/W	Local loopback
RL	DTE	F/W	Remote loopback
SQ	DCE	DCE dep	Signal quality
SF/SR	DTE	F/W	Select frequency/select rate
IS	DTE	F/W	In Service
NS	DTE	F/W	New signal
SRD	DCE	None	Secondary receive data
SSD	DTE	None	Secondary send data
SRS	DTE	F/W	Secondary request to send
SCS	DCE	DCE dep	Secondary clear to send
SRR	DCE	DCE dep	Secondary receiver ready

Where: DCE dep = Depends on external DCE device and connection
F/W = Set by interface Firmware

Transmission mode: Full-duplex, bit-serial synchronous.

Message buffering: Seven frames in either direction (14 frames total, with up to 1024 bytes per frame) may be buffered using the 16k byte on-board RAM memory.

Error detection and correction: Errors are detected using CRC-16 cyclic redundancy checking on all frames sent or received. The interface retransmits, or requests retransmission of all frames with errors to attain error-free data transfer. The maximum number of retransmissions may be user specified. If not user specified, the maximum number of retransmissions initiated by the interface defaults to 10.

Line protocol: The HDLC network interfaces implement a superset of the High Level Data Link Control (HDLC) communications protocol, which is not suitable for general-purpose HDLC communications and should not be used for other than HP 1000-to-HP 1000 communications links in the DS/1000-IV environment.

European licensing of HDLC modem interfaces

Hewlett-Packard has applied for FTZ licensing of the 12007A and 12794A interfaces in Germany and GPO licensing in the United Kingdom. Consult your Hewlett-Packard sales representative on the status of FTZ or GPO licensing of these interfaces if such licensing is important to you.

Configuration information

System compatibility: See table 2.

Table 2. HDLC Network Interface System Compatibility

Interface Product Numbers	Compatible Computers	Compatible Computer Systems	Compatible Operating Systems
12007A & 12044A	2103L	2146A/B	92070A RTE-L
12794A & 12825A	2108M, 2109E, 2111F, 2112M, 2113E, & 2117F	2174A/B, 2175A/B, 2176C/D, & 2177C/D	92068A RTE-IVB & 92064A RTE-M*

* RTE-Mill configuration is required.

Computer I/O channels required: One per HDLC network interface.

Interface current required from computer power supplies:

Interface Product No.	+5V Supply	+12V Supply	-12V Supply
12007A	2.6A	0.35A	0.18A
12044A	2.4A	0.31A	0.04A
12794A	1.93A	0.32A	0.18A
12825A	1.81A	0.27A	0.04A

Counterpart interfaces in other HP 1000 Systems: See Table 1.

Software support: Operation of the HDLC network interfaces is supported by 91750A DS/1000-IV software as described in the 91750A data sheet.

Compatible U.S. modems and communication lines: The 12007A/12794A interface is compatible with the modems listed in Table 3. Strapping requirements and recommendations for U.S. modems used with the 12007A/12794A are given in the 12007A/12794A HDLC Modem Interface Hardware Manual, HP Part Number 12007-90001/12794-90001.

Table 3. Connections, Modems, and Data Rates

Connection via	Model Type	Maximum synchronous Data Rate
Private lines	Bell 201C	To 2400 bits/sec
	Bell 208A	To 4800 bits/sec
	Bell 209A	To 9600 bits/sec
	HP 37210T	To 4800 bits/sec
	HP 37220T	To 9600 bits/sec
	HP 37230A	To 19200 bits/sec

European modems

Contact local European HP sales office for information. European modems and interfaces should have approval of PTT in each country.

12007A/12794A Installation: Set the interface configuration switch for baud rate, internal or external clock, and forced cold load enable/disable. On the 12007A interface, set I/O address on the select code switches and VCP enable/disable. With power off, plug the interface into the computer I/O backplane, connect the supplied cable to the compatible customer-furnished modem, and integrate the interface card and 91750A software into the RTE-L/RTE-IVB/RTE-M operating system.

12044A/12825A Installation: Set the interface configuration switch for baud rate and forced cold load enable/disable. On the 12044A interface, set I/O address on the select code switches and VCP enable/disable. With power off, plug the interface into the computer I/O backplane, fabricate any necessary direct connect extension cables, connect cables between the local and remote 12044A/12825A interfaces, and integrate the interface card and 91750A software into the RTE-L/RTE-IVB/RTE-M operating system.

12044A/12825A Limitations: The 12044A/12825A interface has optical and transformer isolation for voltages up to 1000V, maximum. This isolation is usable only for intra-building communication. Because 12044A/12825A isolation is not intended to survive a lightning strike, these interfaces are not recommended or warranted for connections between buildings.

Ordering information

NOTE: The 12007A, 12044A, 12794A, and 12825A interfaces are for use only in the 91750A DS/1000-IV environment for HP 1000-to-HP 1000 communication links. They are not general-purpose HDLC interfaces.

12007A HDLC Network Modem Interface (for L-Series)

The 12007A interface includes:

- 5061-3417 L-Series Programmable Serial Modem Interface.
- 91750-80001 and 80002 Network Firmware ROMs.
- 5061-3424 5m/17ft RS-232-C Modem Interface Cable.
- 5061-3425 RS-232-C Loop-Back Verifier Hood.
- 12007-90001 HDLC Modem Interface Hardware Reference Manual.

12794A HDLC Network Modem Interface (for M/E/F-Series)

The 12794A interface includes:

- 5061-3418 M/E/F-Series Programmable Serial Modem Interface.
- 91750-80001 and 80002 Network Firmware ROMs.
- 5061-3424 5m/17ft RS-232-C Modem Interface Cable.
- 5061-3425 RS-232-C Loop-Back Verifier Hood.
- 12794-90001 HDLC Modem Interface Hardware Reference Manual.

12007A/12794A Options

001: Provides one set of updated firmware ROMs.

002: Substitutes 5061-3436 5m/17ft RS-449 Modem Interface Cable and 5061-3441 RS-449 Loop-Back Verifier Hood for 12007A/12794A items 3 and 4, listed above.

12044A HDLC Direct Connect Interface (for L-Series)

The 12044A interface includes:

- 5061-3434 L-Series Programmable Serial Direct Connect Interface.
- 91750-80001 and 80002 Network Firmware ROMs.
- 5061-3422 and 3423 Two 5m/17ft direct connect interface cables, one to a male connector, the other to a female connector. Together, these two cables provide a complete link between local and remote HDLC direct connect interfaces, although extension cables (available through options 003 through 005) may be required.
- Two 5061-3421 Direct Connect Loop-Back Verifier Hoods.
- 12044-90001 HDLC Direct Connect Interface Hardware Reference Manual.

12825A HDLC Direct Connect Interface (for M/E/F-Series)

The 12825A interface includes:

1. 5061-3432 M/E/F-Series Programmable Serial Direct Connect Interface.
2. 91750-80001 and 80002 Network Firmware ROMs.
3. 5061-3422 and 3423 Two 5m/17ft direct connect interface cables, one to a male connector, the other to a female connector. Together, these two cables provide a complete link between local and remote HDLC direct connect interfaces, although extension cables (available through options 003 through 005) may be required.
4. Two 5061-3421 Direct Connect Loop-Back Verifier Hoods.
5. 12825-90001 HDLC Direct Connect Interface Hardware Reference Manual.

12044A/12825A Options

- 001: Provides one set of updated firmware ROMs.
- 002: Deletes cables and loop-back verifier hoods (items 3 and 4) from the 12044A/12825A (for second HDLC direct connect interface in a DS/1000-IV link).
- 003: Adds one 5061-3437 75m/255ft direct connect extension cable with assembled connectors.
- 004: Adds male and female connectors for customer-assembly of direct connect extension cable, using cabling purchased from the cable manufacturer.
- 005: Adds male and female connectors and 300m/1020ft of cable for customer assembled direct connect extension cable.



HP 1000 M/E/F-Series Binary Synchronous Modem Interface for DS/1000-IV communication between HP 1000 and HP 3000 Systems

product number 12793A

The 12793A is a microprocessor-based interface that is programmed to manage an RS-232-C or RS-449 modem-based communications link from an HP 1000 M/E/F-Series Computer System to a counterpart interface in an HP 3000 Computer System, when both systems are operating in an HP-DSN environment. The 12793A interface handles all Binary Synchronous protocol generation, CRC-16 error checking, and on-board buffer management functions as well as all modem control tasks. In conjunction with 91750A DS/1000-IV Network software, the 12793A interface supports high level user access between HP 1000 and HP 3000 Systems.

NOTE: The 12793A interface is for use only in the 91750A DS/1000-IV environment for HP 1000-to-HP 3000 communication links. It is not a general purpose Binary Synchronous Interface.

Features

- Support for synchronous full or half duplex modems at rates to 57,600 bits/second
- 16k bytes of RAM memory for extensive on-board message buffering
- Firmware-controlled automatic power-up self test to help assure interface integrity
- Long term communication line statistics are available through user request via DS/1000-IV software to facilitate checks of line quality and assist link troubleshooting
- Binary synchronous interface for DS/1000-IV to DS/3000 communication links with microprocessor management of Bisync protocol, CRC-16 error checking, buffer management, DMA transfers, and modem control tasks

Functional description

On-board microprocessor off-loads host computer

A powerful microprocessor on the 12793A interface manages routine communications processing, freeing the host computer for application oriented tasks. Under control of on-board firmware, the microprocessor converts command words into actions, such as establishing the communications link and loading/unloading data from the on-board buffers to the host CPU. The microprocessor also performs protocol generation and interpretation, error checking, and error recovery by retransmission, all without the attention of the host computer.

Numerous user programmable parameters are available to tailor the interface to specific applications and configurations, which are also managed by the microprocessor. For example, from 0 to 255 retransmissions of blocks in error can be selected by the user, or a default of 7 may be used. The transmission block size can also be specified.

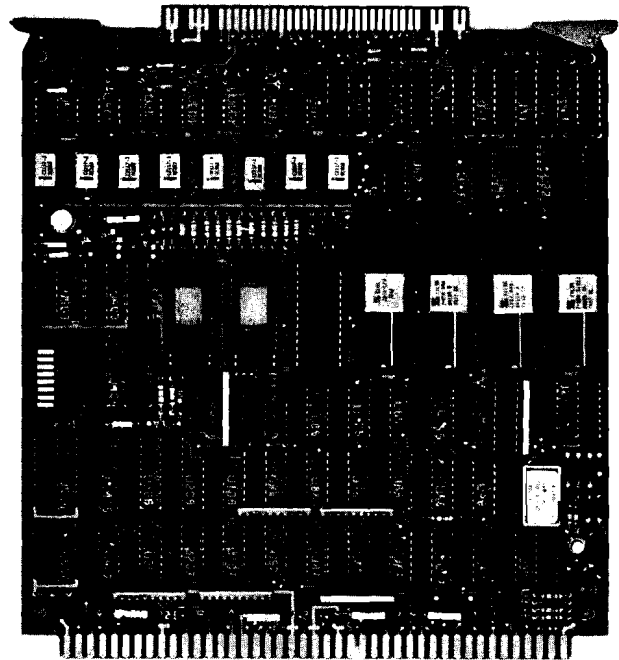

Buffer management parameters are accessible to further adjust link operation for optimal performance. These interface buffer tasks, also microprocessor managed, include packing bytes into words for Direct Memory Access transfers to the host CPU and unpacking words into bytes for transmission.

Firmware controlled self tests

On-board, firmware-controlled self tests, performed at power-up, help to assure reliable operation of the 12793A interface and minimize troubleshooting time. These tests check out the RAM and ROM memories, the Direct Memory Access operations, baud rate generators, and the I/O channel control.

Communications line statistics

Eleven long-term statistics are accumulated automatically and buffered on the interface. These statistics can be easily read by the user to help determine the quality of the communication line and to aid link troubleshooting. They are:

1. Good blocks sent.
2. Good blocks received.
3. Bad blocks received.
4. NAKs received.
5. WACKs sent.
6. WACKs received.
7. TTDs sent.
8. TTDs received.
9. Response errors.
10. Three-second timeouts.
11. Line errors.

Functional specifications

Communications

Interface level: EIA RS-232-C and EIA RS-449.

Internally-clocked, programmable data rates: 300, 1200, 2400, 4800, 9600, 19200, and 57600 bits/second.

Externally-clocked data rates: To 57600 bits/second.

12793A interface signals:

Signal	Source	Default	Function
RD	DCE	None	Receive data
SD	DTE	F/W	Send data
CS	DCE	None	Clear to send
RS	DTE	F/W	Request to send
TR	DTE	F/W	Data terminal ready
RR	DCE	None	Receiver ready (Data carrier detect)
ST	DCE	None	Send timing (Transmit clock)
RT	DCE	None	Receive timing (Receive clock)
TT	DTE	None	Terminal timing
IC	DCE	None	Incoming call (Ring indicator)
DM	DCE	None	Data set ready
TM	DTE	F/W	Test mode
LL	DTE	F/W	Local loopback
RL	DTE	F/W	Remote loopback
SQ	DCE	None	Signal quality
SF/SR	DTE	F/W	Select frequency/select rate
IS	DTE	F/W	In Service
NS	DTE	F/W	New signal
SRD	DCE	None	Secondary receive data
SSD	DTE	F/W	Secondary send data
SRS	DTE	F/W	Secondary request to send
SCS	DCE	None	Secondary clear to send
SRR	DCE	None	Secondary receiver ready

Transmission mode: Bit-serial, synchronous half-duplex, via half-duplex or full-duplex modems and telephone lines.

Message buffering: A maximum of 6432 bytes in each direction (12864 bytes total) may be buffered using the 16k byte on-board RAM memory.

Error detection and correction: Errors are detected using CRC-16 cyclic redundancy checking on all blocks sent or received. The interface retransmits, or requests retransmission of all blocks with errors to attain error-free data transfer. User can specify 0 to 255 retransmissions. If number is not user specified, the maximum number of retransmissions initiated by the interface defaults to 7.

Line protocol: The 12793A interface implements an extended subset of the IBM Binary Synchronous Communications Line protocol and is NOT a general-purpose Binary Synchronous Interface. It should be used only for HP 1000-to-HP 3000 communications links in the HP-DSN environment.

European licensing

Hewlett-Packard has applied for FTZ licensing of the 12793A interface in Germany and GPO licensing in the United Kingdom. Consult your Hewlett-Packard sales representative on the status of FTZ or GPO licensing of this interface if such licensing is important to you.

Configuration information

System compatibility: The 12793A interface is compatible with 2108M, 2109E, 2111F, 2112M, 2113E, and 2117F Computers and 217x Computer Systems operating under the 92068A RTE-IVB or 92064A RTE-M (MIII configuration) real-time executive system.

Computer I/O channels required: One per 12793A interface.

Interface Current required from M/E/F-Series Computer Power Supply: 1.93A(+5V), 0.32A(+12V), and 0.18A(-12V).

Counterpart interfaces in HP 3000 Systems: HP 30010A or 30055A in HP 3000 Series II/III, HP 30020A in HP 3000 Series 30/33.

Software support: Operation of one 12793A interface per system is supported by 91750A DS/1000-IV software as described in the 91750A data sheet.

Compatible U.S. modems and communication lines: The 12793A interface is compatible with the U.S. modems listed in Table 1. Strapping requirements and recommendations for modems used with the 12793A are given in the 12793A Bisync Modem Interface Hardware Manual, HP Part Number 12793-90001.

Table 1. Connections, Modems, and Data Rates

Connection via	Modem Type	Maximum synchronous Data Rate
Switched telephone (Direct Distance Dialing) Network	Bell 201C	To 2400 bits/sec
	Bell 208B	To 4800 bits/sec
	HP 37210T	To 4800 bits/sec
Private lines	Bell 201C	To 2400 bits/sec
	Bell 208A	To 4800 bits/sec
	Bell 209A	To 9600 bits/sec
	HP 37210T	To 4800 bits/sec
	HP 37220T	To 9600 bits/sec
	HP 37230A	To 19200 bits/sec

European modems

Contact local European HP sales office for information. European modems and interfaces should have approval of PTT in each country.

12793A Installation: Set the interface configuration switches for baud rate and internal or external clock and answer mode. Turn off system power, plug the interface into the computer I/O backplane, connect the supplied cable to the compatible customer-furnished modem, and integrate the interface card and 91750A software into the RTE-IVB/RTE-MIII operating system.

Ordering information

12793A Bisync Modem Interface (For M/E/F-Series)

The 12793A interface includes:

- 5061-3418 M/E/F-Series Programmable Serial Modem Interface.
- 91750-80005 and 80006 Bisync Firmware ROMs.
- 5061-3424 5m/17ft RS-232-C Modem Interface Cable.
- 5061-3453 Programmable Serial Interface Diagnostic Test Hood.
- 12793-90001 Bisync Modem Interface Hardware Reference Manual.

12793A Options

- 001:** Provides one set of updated firmware ROMs.
- 002:** Substitutes 5061-3436 5m/17ft RS-449 Modem Interface Cable for 12793A item 3, listed above.



HP 1000 M/E/F-Series Computer Hardwired serial interface and cables

product numbers 12889A and 30220A

The 12889A Hardwired serial interface provides for high speed, asynchronous, long-distance, point-to-point data transfer between two HP 1000 M/E/F-Series Computers, using a 12889A interface in each computer, and separate coaxial cables for sending and receiving to achieve immediate line turnaround. It is also used for communication between a local HP 1000 M/E/F-Series Computer System and an HP 3000 Series II/III System with 30360A Hardwired serial interface via an appropriate length of 30220A cabling.

Features

- Transfer rates to 250k bytes/sec
- Transmission distances to 609m (2000 ft)
- Programmable error detection
- Optically isolated receiver circuit

Functional specifications

Data transfer

Maximum cable length: 304.8m (1000 ft) std; 609.6 m (2000 ft) with option 001.

Maximum data rate: 250k bytes/sec std; 125k bytes/sec with option 001. This is a hardware rate; software overhead will result in slower system throughput.

Transmission mode: Bit-serial, asynchronous, using separate cables to send and receive for immediate line turnaround.

Error detection: Uses a Cyclical Redundancy Code (CRC) technique with a 16-bit feedback shift register that implements a 15th degree polynomial.

Configuration information

Computer and system compatibility: The 12889A is hardware-compatible with HP 1000 M/E/F-Series Computers and with HP 1000 Model 20, 25, 40, and 45 Computer Systems.

Computer I/O channels required: One.

Software support: HP 1000-to-HP 3000 communication is supported in the HP 1000 M/E/F-Series System by 91750A DS/1000-IV software or by 91740A/B DS/1000 software-firmware and 91741A software.

Prerequisite: Appropriate length of 30220A cable for connection to 30360A interface in HP 3000 system. (User can provide his own 75-ohm coaxial cabling, type RG-59/U, or Belden No. 9259, or equivalent, two cables per connection).

Current required from computer power supply: 2.25A(+5V), 0.01A(-2V), 0.125A(+12V), 0.05A(-12V).

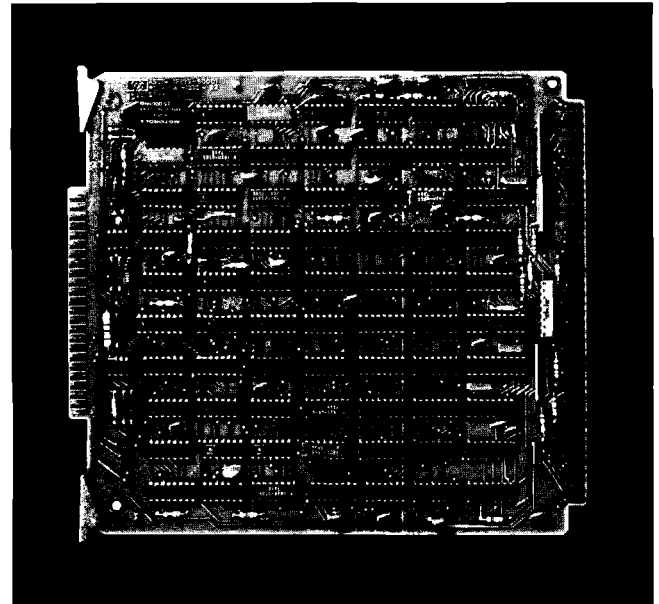

Installation: To install, plug the 12889A interface into the computer I/O backplane, connect the cable from the interface in the local computer and to the counterpart interface in the remote computer, and integrate the interfaces and recommended software into the operating systems of both computers. **The 12889A is recommended and warranted for intra-building communication only.**

Ordering information

12889A Hardwired serial interface

The 12889A Hardwired serial interface includes:

1. 12889-60001 Hardwired serial interface card.
2. 1813-0046 15 MHz clock oscillator.
3. 12889-60004 3.048m (10 ft) Hood and coaxial signal cable assembly.
4. 12889-90001 Interface manual.
5. 02100-90169 Diagnostic manual.

12889A Option 001

Replaces 1813-0046 15 MHz clock oscillator with 1813-0052 7.5 MHz clock oscillator.

30220A 7.6m (25 ft) Cable kit for connection of 12889A interface in HP 1000 computer to 30360A interface in HP 3000 system

30220A options

- 001: Increases cable length to 30.48m (100 ft).
- 002: Increases cable length to 76m (250 ft).
- 003: Increases cable length to 152m (500 ft).
- 004: Increases cable length to 304.8m (1000 ft).
- 005: Increases cable length to 609.6m (2000 ft).



RJE/1000 for HP 1000 M/E/F-Series Computers

product number 91780A

RJE/1000 is a data communications interface package that equips RTE-IV/IVB, RTE-III, or RTE-II based Hewlett-Packard Model 2108, 2109, 2111, 2112, 2113, or 2117 Computers or HP 1000 Model 30, 41, or 46 Computer Systems for Remote Job Entry (RJE) communication with certain IBM 360/370 Systems via telephone lines and user-furnished modems.

Features

- Emulation of IBM 2780 Data Transmission Terminal
- Remote Job Entry (RJE) for batched-job communication with IBM 360/370 using IBM Bisync protocol
- Autoanswer and autoturnaround
- Line speeds to 9600 bits/sec
- Operation in disc-based RTE-IV/IVB, RTE-III, or RTE-II plus BSM system using 7900, 7905, 7906, 7920, or 7925 disc
- Compatibility with BTAM, TCAM, and RTAM access methods
- Choice of ASCII or EBCDIC line code
- Dial-up or private line communication, either half-duplex or full-duplex
- Choice of transparent or non-transparent mode
- Choice of timeout or indefinite wait (if using dedicated leased lines)
- Configurable for variable or fixed-length records
- Supports horizontal tab and vertical format control functions
- Wide choice of input, list, and punch-stream devices
- Trace utility for assisting resolution of data communications problems

Functional specifications

Emulation

RJE/1000 emulates the IBM 2780 Data Transmission Terminal.

System compatibility

Local Hewlett-Packard system

RJE/1000 is compatible with 2108, 2109, 2111, 2112, 2113, or 2117 Computers or HP 1000 Model 30, 41, or 46 Computer Systems operating under RTE-IV/IVB, RTE-III, or RTE-II/BSM real-time executive system.

Remote system

RJE/1000 is compatible with BTAM, TCAM, and RTAM access methods used in the remote IBM 360/370 system. RTAM implies support for HASP, RES, JES/2 and JES/3 scheduler software in IBM systems. It is also compatible with another RJE/1000 in a remote Hewlett-Packard system. In

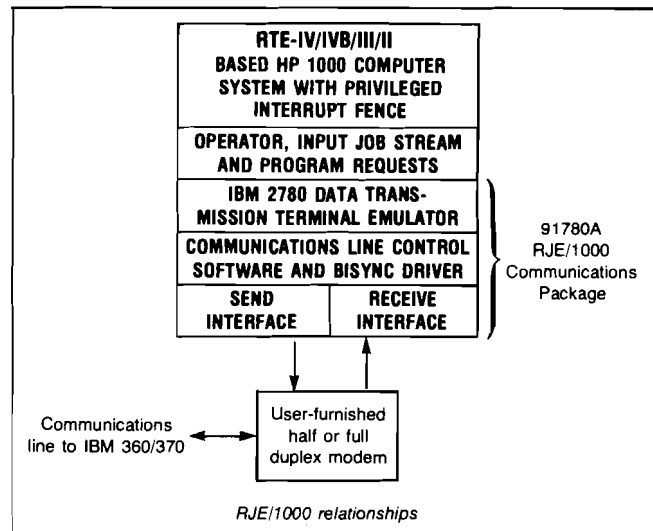

addition, RJE/1000 may be compatible with other host systems or other 2780 emulators, but it is specifically NOT WARRANTED to function with any remote system configuration other than those enumerated above.

Unsupported 2780 features

RJE/1000 does not support these IBM 2780 features:

- Terminal identification.
- Multipoint operation.
- Bell operation.

Connections and modems

RJE/1000 is compatible with the telephone connections and modems listed in Table 1, next page. Regardless of which modem is used, it must meet the following requirements:

1. Synchronous operation.
2. Timing internal to the modem.
3. EIA RS232C or CCITT V.24 compatibility.
4. New Sync is not used.
5. Reverse channel is not used.
6. Unattended answering is optional.
7. Alternate voice should be available for voice coordination.
8. Full-duplex modems may be used to reduce line turn-around time and improve throughput, but half-duplex is the minimum requirement.

Transmission

Data format

The user submits data to RJE/1000 in card and/or printer images for transmission in the same manner as standard tab card and line printer data.

Transmission codes

RJE/1000 is configurable for transmission in either ASCII or EBCDIC code.

Table 1. Connections Modems, and Data Rates

Connection Via	Modem Type	Maximum Synchronous Data Rate, half or full-duplex
Switched telephone (Direct Distance Dialing)	Bell 201A	2000 bits/sec
	Bell 201C	2400 bits/sec
Network	Bell 208B	4800 bits/sec, half duplex only
	HP 37210T	4800 bits/sec
Private lines	Other Non-Bell	4800-9600 bits/sec
	Bell 201B	2400 bits/sec
	Bell 201C	2400 bits/sec
	Bell 208A	4800 bits/sec
	Bell 209A	9600 bits/sec, half, full, or multiplexed†
	HP 37210T	4800 bits/sec
	HP 37220T	9600 bits/sec
	HP 37230A	19200 bits/sec
	Other Non-Bell	4800-9600 bits/sec

†Multiplexed modems allow line sharing by terminals as follows:
 1 terminal at 7200 bps and 1 terminal at 2400 bps
 2 terminals at 4800 bps or 4 terminals at 2400 bps
 1 terminal at 4800 bps and 2 terminals at 2400 bps

RJE input sources at local HP system

Disc files, Mini cartridge tapes, card readers, punched tape reader, 9-track mag tape units, and keyboard-display/printer terminals.

RJE output destinations at local HP system

Disc files, Mini cartridge tapes, line printers, tape punch, 9-track mag tape units, keyboard-printer terminals, and keyboard-display terminals.

Pre-transmission and post-reception formatting

RJE/1000 does not format binary data files for transparent transmission, nor does it reformat them when they are received. Formatting must be accomplished by user's programs.

Distances and data rates

Transmission distance is limited only by the telephone network. Line speeds, up to 9600 bits/sec, are determined by the user's choice of connection and modem, as summarized in Table 1, above.

Multi-record transmission

RJE/1000 blocks and transmits multiple records, which improves throughput by avoiding line turnaround at the end of each record.

Horizontal format control

An electronic tab function identical to the tab on a typewriter allows deletion of spaces in formatted lines, increasing transmission throughput of meaningful data.

Auto turnaround

RJE/1000 automatically switches to receive after sending a message, minimizing line time.

End of media (optional, configurable)

RJE/1000 indicates the end of a record when variable-length records are sent. This reduces line time because trailing blanks in a record are not sent.

Auto answer

RJE/1000 automatically answers an incoming call on a dial-up communication line.

RTE priorities and throughput

RJE/1000 uses privileged interrupt at the highest priority in the RTE system, assuring fast response and maximizing RJE throughput. However, it is possible to set up another privileged interrupt activity in the system. If set up, that other activity must be assigned a lower priority than RJE/1000 to assure proper functioning of RJE/1000.

RJE/1000 control

Operator requests

ON,RJE schedules RJE/1000 with choice of local dialing or answering, sending or receiving data, and translation or transparency enabled. Also specified are the local source and/or destination streams by logical unit number of the peripheral device(s) involved or by the name(s) in a previously-prepared configuration file.

#M provides for on-line configuration or reconfiguration of RJE/1000 options and timeout values prior to start of communications activity.

***BR,RJE** interrupts job stream being received from remote IBM 360/370 system, permitting insertion of HASP commands or other data into the input stream, using the local system console.

ctrl-D terminates the insertion of data, permitting continuation of the original processing.

OF,RJE,1 terminates line activity to get line out of data mode when **#D** cannot be read from the input stream.

Program request

EXEC9,10,23, or 24 Allows a user-written program to schedule RJE instead of using the **ON,RJE** operator command.

Input stream requests

#P provides a pause of specified length during which RJE/1000 waits for data from the remote IBM 360/370 system; the **#P** wait can be requested to occur for each of a specified number of transmissions from the remote system.

#S switches diagnostic messages or the TRACE capability on or off.

#X forces translation of transparent data in the punch stream; **#X** is cancelled by EOT in the punch stream, entry of the **#C** request, or invocation of **#T** stream request after an EOF is received from input.

#E gives automatic line turnaround with approximate 20-second listen time (configurable).

#R gives automatic line turnaround with approximate 60-second listen time.

#W provides automatic line turnaround with continual listening to the line. This feature is for leased-line operations where dial-up line charges are not a factor. The continual wait can be interrupted with the ***BR,RJE** operator interrupt command.

#D causes transmission of disconnect sequence.

#I causes temporary substitution of system console as source of input data stream.

#C,xx changes source and/or destination of input, print, and punch streams. Automatically creates specified files for list and punch streams if they do not already exist.

#T,xx switches RJE/1000 to transparency mode for input from the current input stream device with automatic transfer to logical unit number xx or file with name xx following detection of end-of-file for the current data stream. It also provides for reconfiguration of the list and punch streams as in the **#C,xx** request.

Diagnostic capabilities

Diagnostic messages

The **#S,D,ON** input stream request causes diagnostic messages to be printed out in full, so the operator can determine needed action without the necessity of referring to a diagnostic message table in the manual.

Trace utility (usable only in RTE-III/IV system)

The **#S,T,ON** input stream request causes logging of all communications traffic, together with time of occurrence, onto a user-specified disc file or magnetic tape. At a later time, the user can request that program TDUMP print out the logged communications traffic for analysis, a capability that greatly facilitates localization of communications problems in the link between RJE/1000 and the remote IBM 360/370 system.

System requirements

In RTE-IV/IVB environment: Same as 92068A RTE-IVB or 92067A RTE-IV system, but with 12620A interface for privileged interrupt control.

In RTE-III environment: Same as 92060B RTE-III system, but with 12620A interface for privileged interrupt control.

In RTE-II plus BSM environment: Same as 92001B RTE-II system, but with at least 64k bytes of memory and 12620A interface for privileged interrupt control.

Computer I/O channels used

Three, one each for send, receive, and privileged interrupt control.

Computer interface current required

2.8A(+5V), 0.095A(+12V), 0.07A(-12V), 0.23A(-2V)

Installation and customer's responsibilities

Installation is not included with the RJE/1000 and is therefore the responsibility of the customer, although Hewlett-Packard will provide installation service on request at prevailing service rates. In addition to its installation in the RTE system, integration of RJE/1000 with the remote IBM 360/370 system is also a customer responsibility. To confirm beforehand that such integration is practical, the customer, prior to purchase, must provide the responsible Hewlett-Packard system engineer with accurate information on the following:

1. IBM computer type to be interfaced.
2. Operating system scheduler software and/or access method (HASP, RES, JES/2, or JES/3 and BTAM, TCAM, or RTAM).
3. Whether end-of-media is required.
4. What pad characters are required.
5. Modem and network type.
6. Transmission code used (ASCII or EBCDIC).
7. Baud rate of the modem and telephone line connection.
8. Any other pertinent information bearing on the proposed RJE/1000 link to the IBM 360/370 system.

Ordering information

91780A RJE/1000 communications package

RJE/1000 consists of:

1. Synchronous communications interface cards, receive (12621-60001) and send (12622-60001).
2. Test connector assemblies, receive (12621-60005) and send (12622-60006).

3. Branched cable assembly (12618-60001).
4. 12618A interface operation and service manual (12618-90001).
5. 12621A and 12622A interface manuals (12621-90001) and 12622-90001).
6. RJE/1000 programmer's reference manual (91780-90006).
7. RJE/1000 software numbering catalog (91780-90005).
8. The following software modules on punched tape.
 - a. RJE/1000 main relocatable program.
 - b. **#COMM** bisync timeout values and data buffers module.
 - c. **#DIAL** manual dialing program.
 - d. DVR50 system-resident bisync driver front-end.
 - e. **#BSC** bisync driver.
 - f. TRACE composite relocatable.
 - g. TDUMP composite relocatable.

91780A Options

- 020:** Replaces the paper tape software modules listed under item 8, above, with software on one HP Mini cartridge.
- 100:** Provides discount for upgrade from previous revision of 91780A to latest revision to customers without 91780S/T.

Additional equipment required for operation

1. 12620A breadboard interface, used for privileged interrupt control in RTE operating system.
2. IBM 360/370 with HASP, RES, JES/2, or JES/3 scheduler software or the BTAM, TCAM, or RTAM access method and suitable telephone and modem communications link.

Software support products available

91780T Customer Support Service for 91780A software

91780V Central support for an additional copy of 91780A

91780S Software Subscription Service for 91780A software

91780Q Manual Update Service for 91780A software manuals

91780S&T Media options

010: Software updates on paper tapes.

020: Software updates on phase-encoded Mini cartridges for read-in via 2645A +007 or 2648A +007 CRT display terminals.



Multipoint terminal subsystem software package for HP 1000 M/E/F-Series Computers

product number 91730A

The 91730A is a software support package for multipoint terminal communication between HP 2645A, 2648A, 2649B, and/or 2649C display terminals and an HP 1000 Computer System, using the HP 12790A Multipoint Terminal interface. The 91730A software also supports HP 3075A and 3076A Data Capture Terminals and HP 3077A Time Reporting Terminals, either on their own multipoint line or on the same multipoint line as 264x multipoint display terminals.

Features

- Supports single I/O channel communication with multiple display terminals and/or data capture terminals on a single communications line
- Program development and/or application program execution at multipoint terminals on RTE-IV/IVB based systems
- Application program execution on RTE-MIII based systems
- Computer-interface block transfers up to 1000 characters long at DCPC (direct memory access) rates
- Support for up to eight 12790A Multipoint terminal interfaces
- Multipoint master application program capability
- Multipoint network status display program
- "Who Are You" command identification of multi-point terminals
- Auto acknowledgement of data entry
- Group and line message broadcast capability
- Intelligent polling algorithm
- System level exerciser program
- Power fail restart subroutine
- Supports communication with Minicartridges and auxiliary printers on multipoint display terminals and multifunction readers and printers on data capture terminals

Functional description

Data capture terminals on multipoint

HP 3075A and 3076A Data Capture Terminals and HP 3077A Time Reporting Terminals are application-specific units that operate in the multipoint communications environment under the 92080A DATACAF/1000 applications software or user-written applications software. For more information about their capabilities, see the 92080A data sheet in the HP 1000 Software Technical Data book and the Data capture peripherals section in the HP 1000 Peripherals Data book.

Multipoint terminal usage

User-written application programs access multipoint terminals by their Logical Unit (LU) number. Reading from and writing to terminals is supported from both FORTRAN

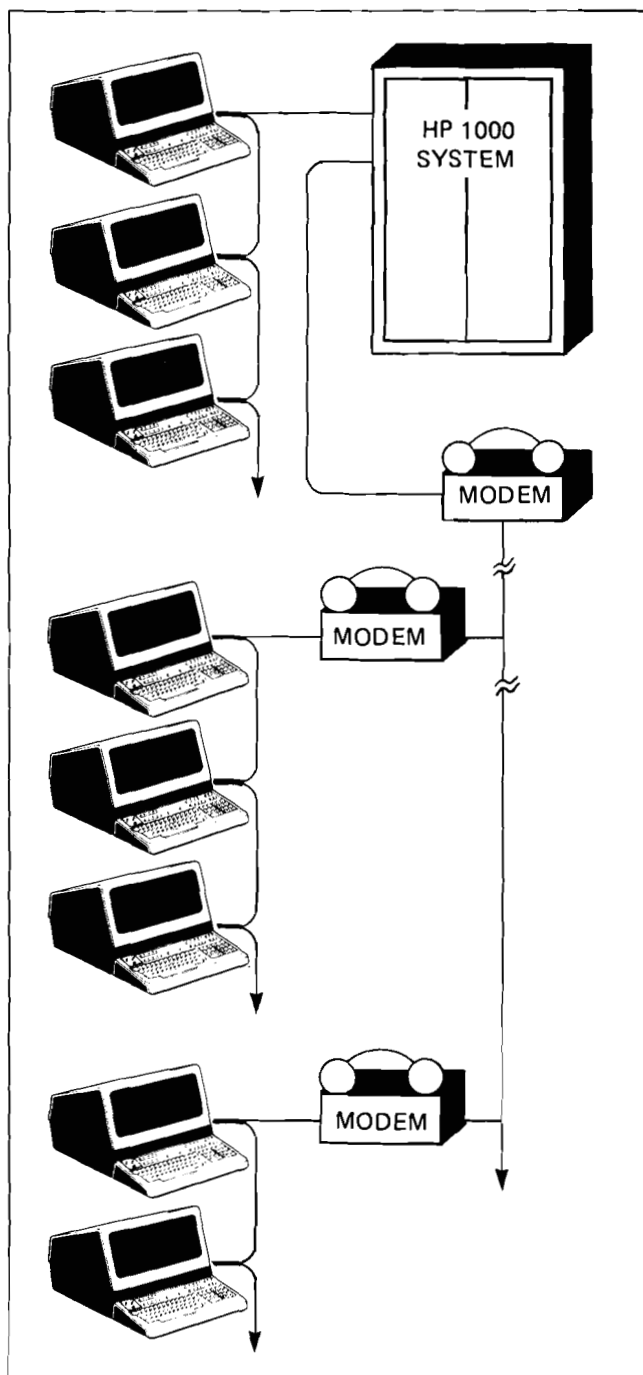

The 91730A Multipoint Terminal Interface Subsystem Software Package supports connection of multiple 2645A, 2648A, 2649B, and/or 2649C Display Terminals to HP 1000 Computers or systems, as shown above, via single hardwired or modem communications lines and the 12790A Multipoint interface.

READ/WRITE statements and RTE EXEC calls. Each multipoint terminal can be running under the control of its own unique application program for read and write only. Therefore, a single communications line and computer I/O channel can be shared and effectively utilized. Multipoint software driver DVR07 queries the status of all terminals in sequence such that: (1) Pending Read, Write, and Control requests to a terminal can be serviced, and (2) an enabled terminal can be "routinely polled" and can thereby get RTE system attention or can schedule a multipoint master application program. This querying process is transparent to the user's application program. Users at multipoint terminals can develop new application programs, each utilizing a copy of the RTE File Manager, Editor, FORTRAN IV compiler, RTE Assembler, or BASIC/1000D interpreter, in the RTE-IV/IVB system.

Data transfer mode

All data transfers between the buffer on the 12790A Multipoint interface and the user's application program is done via direct memory access under the control of the Dual Channel Port Controller (DCPC). All multipoint terminals operate in block mode and make use of the ENTER key on the 264x or data capture terminal to transmit a message to the system. Direct memory access transfers are extremely fast (approximately 160k bytes per second) and are very efficient for medium to long blocks of text.

Support of user-written master application program

Multipoint supports provision of a user-written master application program to facilitate control of application environments by multipoint terminal users. This program might, for example, display a menu of many application programs from which the terminal operator can choose. The choice could be easily implemented with a 264x "soft" key. The master application program can be scheduled by depressing the ENTER key, or one of the soft keys when DVR07 does not expect any terminal response to its routine poll. That would be the case if there is no application program read request pending on the terminal. Also, if a long write to a terminal is in progress and the appropriate edit mode flag has been set, the user could depress the BREAK key, which would cause DVR07 to schedule the master application program after the next block mode write.

Auto acknowledgement

Multipoint software optionally provides for audible auto acknowledgement at any multipoint terminal. As soon as the 12790A Multipoint interface has unloaded a message to the computer system, an audible response is sounded at the terminal, alerting the operator that data can now be entered. This saves user application program overhead and provides a quicker response to the operator.

Multipoint status display

The multipoint software includes a program which displays pertinent information about all currently active multipoint lines and terminals. By terminal LU, it displays terminal ID and availability, Equipment Table number and status, the active program's name, the status of the edit mode flags, whether routine polling is enabled, and a number of other parameters. The display device can be one of the multipoint terminals.

Terminal status querying and initialization

A "Who Are You" command available to the application programmer obtains the device identification and status of every operational (power turned on) terminal within a group

of terminals on a multipoint line. A Group is a logical subset of all of the terminals connected to the multipoint line. The terminals respond in the sequence of their physical position within the group. Then, if the system has been suitably generated, it is possible to programmatically initialize all the terminals within the group so that each may begin an application program or program development. Alternatively, multipoint terminals can be initialized by File Manager control commands from the system console.

Message broadcasting

The multipoint software provides the ability to broadcast a message simultaneously to all of the terminals in a group, or all of the terminals on a multipoint line. This ability assists in the efficient coordination of management of a multipoint applications environment.

Access to multipoint terminal minicartridges and auxiliary printers

A multipoint software subroutine provides for the transfer of data between user's programs in the computer and Mini cartridges on multipoint terminals. This same subroutine also supports direct output to an auxiliary printer connected to multipoint terminals. Direct communication between the RTE File Manager and Mini cartridges or auxiliary printers on multipoint terminals is not supported.

Transparent transmission

Multipoint software and interface card firmware support the transparent transmission of binary data as well as ASCII screen-displayable characters.

Intelligent terminal servicing

Multipoint software driver DVR07 implements an intelligent terminal servicing algorithm which prevents line monopolization by a single terminal while prioritizing activity on the multipoint line. DVR07 queries the status of each terminal sequentially and directs the 12790A to generate Bisync Poll Messages (for Reads and Routine Polls) or Bisync Select Messages (for Writes or Control requests), as determined by the algorithm. In a status inquiry at a given terminal, DVR07 checks for active Write, Read, or Control requests from a system or user program. A Control request or a Write to a terminal, if pending, is serviced immediately. A Read from a given terminal is done after the status of all other terminals on the multipoint line has been queried once. No more than 1000 characters of text can be written to or read from a given terminal before a status inquiry is performed on all terminals in sequence. Likewise, if a status inquiry for a terminal shows no active Write, Read, or Control requests, then that terminal will, if enabled, be "routinely polled" for operator intervention to get RTE system attention or schedule the multipoint master application program **after** a status inquiry of all other terminals on the multipoint line has been performed once. In this way, the intelligent terminal servicing algorithm gives Writes and Control requests priority over Reads and Routine Polls. It also prevents one terminal from monopolizing the line by doing a status inquiry at all other terminals (and potentially servicing them) before more than 1000 characters in a long message are transmitted to or from that one terminal. Each terminal operator thus has equal access to the resources of the system.

System level exerciser

A system-level exerciser program is supplied with the multipoint software. The exerciser sends a specified terminal one or more lines of data, and causes the same lines of data to be transmitted back to the exerciser program for verifica-

tion. The exerciser is useful in verifying the integrity of the multipoint network and helpful in isolating a malfunction.

Functional specifications

Compatibility

Operating system: 92064A RTE-M system (RTE-MIII configuration) for application program execution and 92067A RTE-IV or 92068A RTE-IVB system for both application program execution and program preparation.

Hardware: 12790A Multipoint terminal interface and cable and 264x Display terminals which are compatible with that interface and/or HP 3075A and 3076A Data Capture Terminals and HP 3077A Time Reporting Terminals.

Number of terminals per multipoint line

Normally, up to 32 terminals can be connected to the 12790A interface via a single multipoint line. The following three important factors determine the number of terminals which can be connected:

1. The number of terminals that can be *physically* connected depends upon the transmission mode. Asynchronously, up to 32 terminals can be *physically* connected; the distance between any two terminals can be 609 metres (2000 ft), provided that the total line length does not exceed 4876 metres (16000 ft), regardless of transmission speed up to a maximum of 9600 bps. For synchronous operation, the maximum distance between any two terminals is also 609 metres (2000 ft) and maximum total line length is also 4876 metres (16000 ft), but the number of terminals per line depends upon the average distance between terminals and line speed, as summarized in Table 1.
2. The maximum number of *logically connectable* terminals may be constrained by the logical unit number of capacity of the RTE operating system in which the 12790A and its supporting 91730A software are operated.
3. Finally, the number of terminals that can be *realistically* supported depends upon the amount of text character I/O generated by each terminal on the line, the length of those text blocks, the speed of the line itself, and other user-dependent requirements, such as response time.

Table 1. Average line lengths between multipoint terminals on a synchronous line

Terminals per line	Average line length versus line speeds of:		
	2400 bps	4800 bps	9600 bps
4	609m (2000 ft)	609m (2000 ft)	609m (2000 ft)
8	609m (2000 ft)	609m (2000 ft)	365m (1200 ft)
16	609m (2000 ft)	365m (1200 ft)	146m (480 ft)
32	365m (1200 ft)	146m (480 ft)	36.5m (120 ft)

Maximum system usage per 12790A interface

The maximum requirement for time that would otherwise be available to a compute-bound user program in the RTE system occurs during Routine Polling while there is no Read, Write, or Control communication with any of the multipoint terminals. This is true for the no-communication condition because that results in the highest rate of HP 1000 computer interrupts and therefore imposes a maximum demand on system processing time. System usage is essentially independent of the number of terminals on the multipoint line, but is a direct function of the number of 12790A interfaces and is also dependent upon the transmission mode and line speed. The following usage figures apply to operation of the 91730A Multipoint software in an HP 1000 E-Series Computer with standard performance memory operating under RTE-IV;

Transmission Mode:	Synchronous	Asynchronous
Line speed:	9600 bps	9600 bps
Approximate requirement for otherwise user-available processing time	6%	10%

RTE system capabilities accessible from multipoint terminals

The multipoint software, gives multipoint terminals the same access to system capabilities as non-multipoint terminals, except that:

1. Intra-line character edits (CTRL/R,I,C,T to Replace, Insert, Cancel, or Truncate characters) are not effective in the multipoint environment wherein whole lines are transmitted to the RTE EDITR at a time. However, the multipoint terminals have the intelligence, buffering, and predefined keys to support selective forward tab spacing and backspacing, and the replacement, insertion, or deletion of characters within a line without interrupting the 12790A interface.
2. Terminal peripherals, such as Mini cartridges, are addressed as subchannels to the Terminal Logical Unit. Therefore, while multipoint subroutines can access the terminal peripherals, there is no direct interface between the RTE File Manager and those peripherals.

Minimum system requirements

Same as RTE-IV/IVB system or RTE-MIII (multi-user) configuration of RTE-M system plus an HP 12790A Multipoint terminal interface and one or more 2645A, 2648A, 2649B, and/or 2649C Display terminals configured to be compatible with the 12790A interface (see 12790A data sheet for more information). One or more HP 3075A, 3076A, and/or 3077A Terminals are also usable with the additional support in RTE-IVB of the 92080A DATACAP/1000 software.

Power fail restart

Working in conjunction with the RTE power fail/auto restart routines, a power fail restart subroutine furnished with the multipoint software resets each 12790A interface in the system so that I/O may resume after a power failure. This subroutine also runs the 12790A firmware-controlled self test. If the power failure occurred during a phase of the I/O operation from which recovery is not possible, an I/O error message is sent to the system console. A power failure message is broadcast to all multipoint terminals on the system.

Approximate memory requirements

Multipoint driver DVR07: 2500 bytes
Terminal peripheral subroutine: 850 bytes
Power fail restart subroutine: 120 bytes*
System-level exerciser program: 4200 bytes*
System status program: 2460 bytes*

*These subroutines and programs can be placed in the resident library or appended to a user's application program.

Ordering information

91730A +020 Multipoint terminal subsystem software package

The 91730A +020 package consists of:

1. Software on Mini cartridge.
2. Multipoint software numbering catalog (91730-90001).
3. Multipoint user's guide (91730-90002).

Software support products available

92730T +020 Customer Support Service for 91730A software (updates on Mini cartridges)

91730V Central support for additional copy of 91730A

91730S +020 Software Subscription Service for 91730A software (updates on Mini cartridges)

91730Q Manual Update Service for 91730A software manuals



HP 1000 M/E/F-Series Multipoint terminal subsystem interface

product number 12790A

The 12790A Multipoint Terminal Subsystem Interface is a microprocessor-based interface card that is microprogrammed to manage a hardwired or modem-based RS232C interface, the Binary Synchronous 2645A Multipoint Line protocol, and an on-board data buffer. In conjunction with the 91730A Multipoint Terminal Subsystem Software Package, the Multipoint Interface supports 2645A, 2648A, 2649B, and/or 2649C Display Terminals in **block mode for program development or program execution under the control of one or more user application programs**. In the RTE-IVB operating system environment with 92080A DATACAP/1000 applications software, the Multipoint interface plus multipoint software also supports HP 3075A and 3076A Data Capture Terminals and HP 3077A Time Reporting Terminals. HP 3075A, 3076A, and HP 3077A Data Capture Terminals can operate on the same multipoint line as 2645A and 2648A CRT Display Terminals, **operating in asynchronous polled block mode**.

Hardware and firmware features

- Microprocessor management of 2645A Multipoint Protocol, line/modem control signals, and on-board data buffer
- Nominally, up to 32 2645A, 2648A, 3075A, 3076A, and/or 3077A Terminals per multipoint line
- Hardwired or modem-linked communications
- Full-duplex or half-duplex modem compatibility
- Synchronous or asynchronous communication at rates to 9600 bits/second
- CRC-16 error checking
- 1024 byte RAM memory for I/O operations
- Firmware-controlled self tests
- Compatibility with HP 1000 M, E, and F-Series Computers and powerful 2645A/2648A/2649B/2649C capabilities
- Sharing of communications resources

Functional description

Sharing of communications resources

With multipoint as opposed to point-to-point operation, a number of 2645A/2648A/2649B/2649C/3075A/3076A/3077A terminals can share valuable communications resources, including the daisy-chained hardwired or modem-based communications line, the HP 1000 computer I/O channel, the interface card, and modems, if used.

Built-in microprocessor off-loads the computer

A powerful, control-oriented microprocessor on the 12790A interface manages routine communications processing, freeing the computer itself for applications-oriented tasks. The multipoint protocol implemented on the interface is 2645A Multipoint Protocol, which is similar to IBM Bisync.

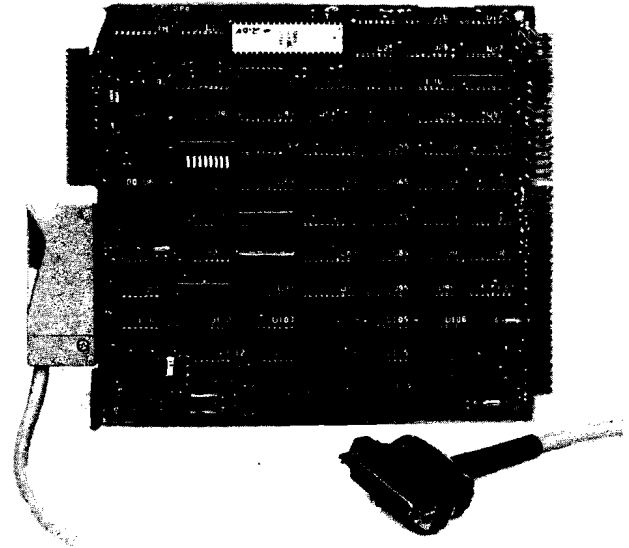

Under the control of firmware, the microprocessor converts a control word into actions, such as polling a terminal for data, selecting a terminal for a write, or loading/unloading text. CRC-16 Cyclical Redundancy Error Checking is performed on the interface for all text blocks received or sent. The microprocessor automatically requests up to 8 retransmissions upon detection of an error, unless directed to request any other number of retransmissions from zero to 16 by the user's program.

The microprocessor also manages synchronous or asynchronous modem control signals and is capable of setting additional modem control lines, such as rate Select, upon receiving the appropriate command word from the user's program. A controllable watchdog timer is used to generate communications line timeouts.

The microprocessor manages the data buffer used to store blocks of data being sent to or received from the computer. This buffer management includes packing bytes into words for direct memory transfers to the computer via DCPC and unpacking words into bytes for transmission to terminals.

Finally, under programmatic initiation, the interface can perform several optional text editing functions automatically. On writes to a terminal, these include "homing" the terminal's cursor, clearing the display screen, and/or appending a carriage return/line feed after the last character of text. On reads from a terminal, the interface strips group separators and optionally can strip carriage returns, line feeds, and/or the record separators which define protected fields on the 2645A/2648A/2649B/2649C.

Bisync multipoint protocol

The 12790A interface supports a character-oriented Bisync Multipoint Protocol that manages the communications activ-

ity on a multipoint line. Message sequences, for example, define which terminal is to be selected for a write from the computer or which terminal is to be polled for text to be read into the computer. The message sequences also report whether an addressed terminal is ready for I/O and transfer user's text to and from the terminal. Protocol characters frame each message and also provide error control on any text blocks transferred in a given message. The activity on a multipoint line thus consists of protocol-related characters and terminal user text characters.

Built-in text buffering for efficient operation

For any given line speed, large block mode character transfers make the most efficient use of protocol characters, communications line capacity, and computer processing time. For that reason, the 12790A interface incorporates a 1024-byte random access memory which allows up to 998-byte block data transfers to the computer and up to 1000-byte block transfers from the computer to the interface. All transfers are directly to or from the computer memory via the Dual Channel Port Controller (DCPC) in the computer, which promotes extremely efficient utilization of each interrupt to the computer and of every request sent over the communications line. One block mode data transfer can fill over half of a terminal's display screen. Messages longer than 1000 bytes can be transmitted by multiple block mode data transfers of approximately 1000 bytes each. DCPC access to the computer is thus consistent with, and supports, the high performance block mode capabilities of the 12790A interface plus 91730A multipoint software.

Firmware-controlled self tests

On-board firmware-controlled self tests help assure reliable operation of the interface. These check out the data buffer, the baud rate generator used for asynchronous communications, and certain logic functions. The self tests are invoked by the PRESET button on the computer and the results are checked by driver DVR07 in the 91730A Multipoint Terminal Subsystem Software upon initializing a communications line.

Functional specifications

Interface level

EIA RS232C and CCITT V.24.

Transmission mode

Bit serial, asynchronous or synchronous via hardwired cables or half or full duplex modems and telephone lines.

Number of terminals per multipoint line

Nominally, up to 32 terminals can be connected to the 12790A interface via a single multipoint line. The following three important factors determine the number of terminals which can be connected:

1. The number of terminals that can be *physically* connected depends upon the transmission mode. Asynchronously, up to 32 terminals can be *physically connected*; the distance between any two terminals can be 609 metres (2000 ft), provided that the total line length does not exceed 4876 metres (16000 ft), regardless of transmission speed up to a maximum of 9600 bps. For synchronous operation, the maximum distance between any two terminals is also 609 metres (2000 ft) and maximum total line length is also 4876 metres (16000 ft), but the number of terminals per line depends upon the average distance between terminals and line speed, as summarized in Table 1.

2. The maximum number of *logically connectable* terminals may be constrained by the logical unit number capacity of the RTE operating system in which the 12790A and its supporting 91730A software are operated.
3. Finally, the number of terminals that can be *realistically supported* depends upon the amount of text character I/O generated by each terminal on the line, the length of those text blocks, the speed of the line itself, and other user-dependent requirements, such as response time.

Line lengths

Interface to nearest terminal or modem: 15.2 metres (50 ft), maximum.

Maximum length between any two terminals: 609 metres (2000 ft).

Maximum total line length: 4876 metres (16000 ft), not including distance between modems.

Table 1. Average line lengths between multipoint terminals on a synchronous line

Terminals per line	Average line length versus line speeds of:		
	2400 bps	4800 bps	9600 bps
4	609m (2000 ft)	609m (2000 ft)	609m (2000 ft)
8	609m (2000 ft)	609m (2000 ft)	365m (1200 ft)
16	609m (2000 ft)	365m (1200 ft)	146m (480 ft)
32	365m (1200 ft)	146m (480 ft)	36.5m (120 ft)

Character buffering

Maximum of 998 characters from interface buffer to computer, 1000 characters from computer to interface buffer.

Error detection and correction

Errors are detected using CRC-16 cyclical redundancy error checking on blocks received or sent. Interface retransmits, or requests retransmission of block with error to attain error-free data transfer. User can program-specify any number of retransmissions up to 16; if not user-specified, the number of retransmissions is defaulted to eight.

Line continuity past a "down" terminal

Optional 13232T Power Protect Multipoint Cables can be used for terminal-to-terminal connection after the first terminal in a cluster to ensure line continuity through a terminal that is down. If the 30037A Asynchronous Repeater is used, the first terminal can also be protected with a 13232T Power Protect Cable.

Multipoint line protocol

The 12790A interface implements 2645A Multipoint Protocol, which is similar to IBM Bisync.

Configuration information

Computer compatibility: The 12790A Multipoint interface is compatible with 2108, 2109, 2111, 2112, 2113, and 2117 Computers operating under RTE-MIII, RTE-IV/IVB real time executive system.

Computer I/O channels required: One per interface.

Compatible CRT display terminals: 2645A, 2648A, 2649B, and 2649C Terminals, which also require 13234A 4k byte terminal memory module, and 264x option 033 (asynchronous) or 264x option 034 (synchronous) Multipoint communications with Monitor mode capability.

Compatible data capture terminals: 3075A, 3076A, and 3077A Terminals using asynchronous polled block mode only.

Compatible modems: See Table 2.

Table 2. Connections, Modems, and Data Rates

Connection via	Modem Type	Maximum Data Rate
Switched Telephone (Direct Distance Dialing) Network	Bell 201A3	To 2000 bits/sec
	Bell 202T	To 1200 bits/sec
	Bell 208B	To 4800 bits/sec
	Bell 212A	To 1200 bits/sec
	HP 37210T	To 4800 bits/sec
Private lines	Vadic VA3400	To 1200 bits/sec
	Bell 201A3	To 2000 bits/sec
	Bell 202T	To 1800 bits/sec
	Bell 208A	To 4800 bits/sec
	Bell 209A	To 9600 bits/sec
	HP 37210T	To 4800 bits/sec
	HP 37220T	To 9600 bits/sec
	HP 37230A	To 9600 bits/sec*

* Limited by maximum speed of 2645A Multipoint lines.

Current required from computer power supply: 2.5A(+5V), 0.1A(+12V), 0.05-12V), 0.06A(-2V).

Software support: Operation of the 12790A interface in RTE-M (RTE-MIII configuration) and RTE-IV/IVB systems is supported by the 91730A Multipoint Terminal Subsystem Software package, which has the following set of features, described in the 91730A data sheet:

- Program development and/or application program execution at multipoint terminals on RTE-IV/IVB based systems
- Application program execution on RTE-MIII based systems
- Support for up to eight 12790A interfaces
- Multipoint network status display program
- "Who are you" command to get status of multipoint terminals
- Auto acknowledgement of data entry
- Group and line message broadcast capability
- Intelligent line polling algorithm
- System level exerciser program
- Power fail restart subroutine

Configuration recommendations:

1. At least one terminal in each local cluster, preferably the one closest to the computer or modem, should be equipped with Monitor mode (13260C/D option 001, which is included with 264x options 033 and 034) to aid in troubleshooting a data communications environment.
2. The 13232T Power Protect Multipoint Cable should be used where terminals are located remotely from each other such that easy audible or visual communication is not possible. However, this capability is supported only on multipoint lines in which the 264x Terminals with power protect are closer to the computer than any 3075A, 3076A, or 3077A Terminals that may share use of the line.

Installation: To install, set the 12790A configuration switches for Baud rate, synchronous or asynchronous operation, and modem control; plug the interface into the computer I/O backplane; connect the standard hardwire interface cable to the first terminal or the option 001 cable to a customer-furnished synchronous or asynchronous modem; integrate the interface and 91730A software into the RTE-MIII, or RTE-IV/IVB operating system, and complete remaining connections to terminals. (See Figure 1.) (NOTE: The 12790A and 91730A ordered with an HP 1000 Model 41 or 46 Computer System will be included in the primary system. When both the 12790A and 91730A are ordered on an HP 1000 Model 20 or 25 Computer System with sufficient memory to support the RTE-MIII configuration they will be custom-generated into the system.)

Ordering information

12790A Multipoint Terminal Subsystem Interface

The 12790A interface consists of:

1. 5061-1389 Multipoint interface card.
2. 12790-80006 through 80009 Control Roms.
3. 5061-1393 10.6 metre (35 ft) interface cable for hardwire connection to first 13232P cable on multipoint terminal.
4. 12790-90001 Multipoint Terminal Interface Subsystem Reference Manual.

12790A Options

001: Substitutes a 7.6 metre (25 ft) interface-to-modem cable (5061-1391) for the 5061-1393 hardwire cable, item 3, above.

Additional equipment required for operation

Multipoint terminals: One or more 2645A Display Stations, 2648A Graphics Terminals 2649B OEM Block or Character Mode Terminals, and/or 2649C OEM Graphics Terminals each equipped with:

1. Option 033 or 034.
2. 13234A 4k byte terminal memory module.

Cable for connection to first terminal:

13232P 4.5 metre (15 ft) modem or multipoint cable for connection to first terminal, with provision for connection to multipoint cable for next terminal.

Modem bypass cable: 13232U 1.5m (5 ft) cable for connection between 12790A option 001 modem cable and 13232P cable.

Cables for connection to succeeding terminals:

1. 13232Q 4.5 metre (15 ft) multipoint cable for continuation of multipoint line.
2. 13232R 30.4 metre (100 ft) multipoint extension cable.
3. 13232T 9 metre (30 ft) Power protect multipoint cable providing continuity around "down" terminal.



HP 1000 M/E/F-Series 8-Channel Asynchronous Multiplexer Subsystem

Computer Museum

product number 12792A

The 12792A Subsystem consists of a high speed asynchronous multiplexer interface and supporting RTE software. The 12792A can interface up to eight asynchronous teleprinter-like terminal devices to an HP 1000 M/E/F-Series Computer System using a single I/O channel.

Features

- Inexpensive multiport interface for up to 8 devices increases terminal I/O capacity of system at low per-terminal interfacing costs
- EIA RS-423-A and RS-232-C/CCITT V.24 compatibility
- Programmable data rates using two baud rate generators to eliminate hardware speed strapping
- Programmable character size, parity checking, and number of stop bits for flexible control of transmission format
- On-line break detection for fast response to operator interrupts at terminals
- Parity, overrun, and framing error detection minimizes the possibility of undetected transmission errors
- Full duplex or Echoplex transmission
- Downloadable firmware diagnostic for assuring the integrity of the multiplexer
- Edit backspace and line delete capabilities support intelligent editing
- On-board microprocessor off-loads computer
- On-board buffering with DMA capability speeds multiplexer communication with the computer and minimizes cpu interrupts
- Easily expandable software support through customer-written device drivers

Functional description

The 12792A Asynchronous Multiplexer Subsystem provides multiplexed terminal support for up to eight asynchronous RS-232-C compatible devices hardwired, or connected through full-duplex asynchronous modems, to the multiplexer. The multiplexer hardware/software subsystem can operate at programmable data rates up to 19,200 bits/second on a given channel with an aggregate throughput capability of 76,000 bits/second (8 channels x 9,600 bits/second). A separate, eight-junction Multiplexer panel, product number 12828A, is offered to provide for convenient connection to the 12792A subsystem via EIA 25-pin connectors. For more information, see the 12828A data sheet.

In a single interface card slot, the 12792A Multiplexer Subsystem replaces the interfacing capabilities of eight point-to-point interfaces. It thereby frees up to seven valuable cpu I/O channels for other uses and significantly reduces interface power requirements.

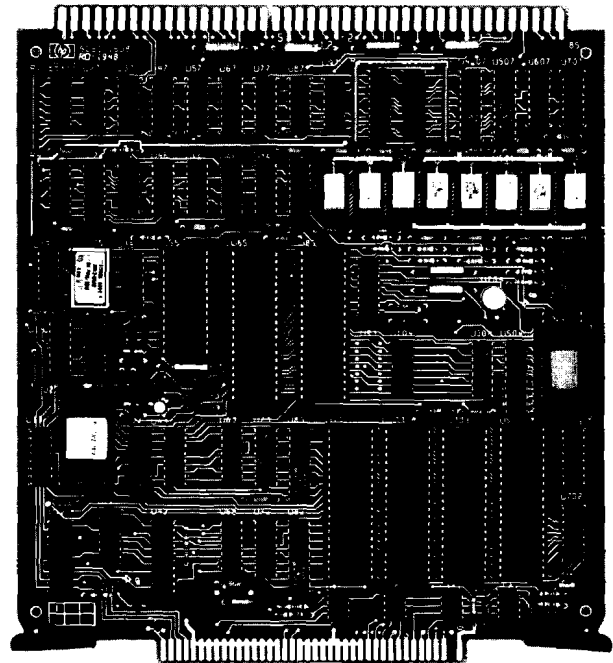

On-board buffering and a control-oriented microprocessor off-load most of the communications control and processing burden from the cpu, freeing significant processing capacity for applications use and maximizing data rates.

Downloadable firmware-controlled self tests exercise the RAM, ROM, and control circuits of the multiplexer, assuring its integrity. Test status is returned to the cpu upon completion of self test.

Functional specifications

Capacity

Channels: Eight full-duplex (transmit and receive) communications channels.

Buffer: Two 254 byte transmit buffers and two 254 byte receive buffers for each channel.

Communications

Interface level: RS-423-A/RS-232-C or CCITT V.24.

Program-selectable data rates: 50, 75, 110, 134.5, 150, 300, 1200, 1800, 2400, 3600, 4800, 9600, and 19200 bits/second.

Aggregate throughput capacity: 7,680 characters/second/interface (8 channels at 960 characters/second).

Communication mode: Asynchronous, bit serial.

Other programmable communications parameters: Character length from 5 to 8 bits, start, stop, and parity.

CPU overhead per active multiplexer channel (% of total cpu time): See Figure 1.

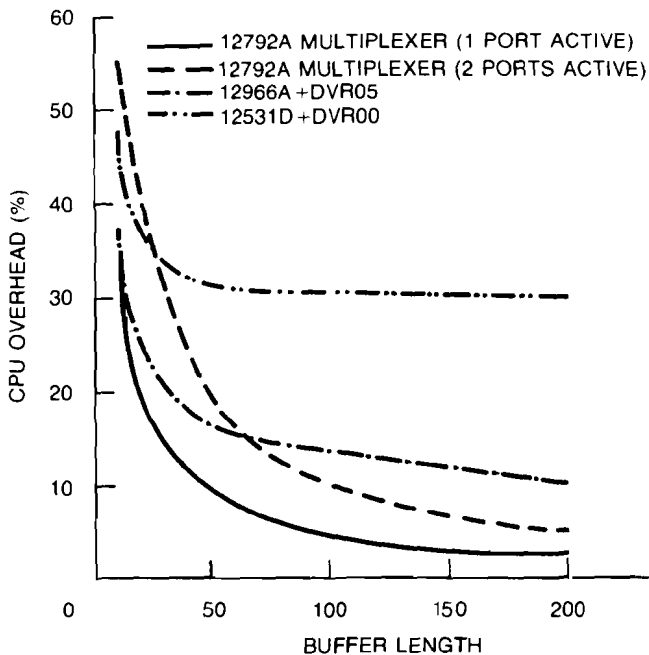

Figure 1. 12792A Computer overhead compared with HP 1000 M/E/F-Series point-to-point interfaces, 9600 baud transfers

Configuration information

System compatibility: The 12792A Subsystem is compatible with HP 1000 M/E/F-Series Computer Systems operating under the RTE-IVB or RTE-MIII real-time executive system.

Computer I/O channels required: The 12792A Multiplexer requires a single I/O channel.

System capacity: Determined by the real-time operating system; up to 62 devices (RTE-MIII) or 61 devices (RTE-IVB) may be connected via an appropriate number of 12792A multiplexer interface cards.

Software support: Software support for the 12792A Asynchronous Multiplexer Subsystem is included with the 12792A product.

Currently supported Hewlett-Packard terminals: 2621A/P Interactive Terminals, 2631A/B Printers, 2635A/B Printing Terminals, 2640B Display Terminal, 2645A Display Station, 2647A Intelligent Graphics Terminal, 2648A Graphics Terminal, 2649B OEM Block or Character Mode Terminal, 2649C OEM Graphics Terminal, 2649G OEM Intelligent Graphics Terminal, and 7310A Graphics Printer.

Current required from computer power supply: 2A(+5V), 0.3A(+12V), 0.04A(-12V).

Approximate memory requirements: See Table 1.

Driver partition requirements in RTE-IVB: A minimum two-page driver partition will be required. The addition of user-written logical drivers may increase this requirement.

Installation: Plug the multiplexer card into the computer I/O backplane and connect to terminals using the furnished

Table 1. 12792A Memory Requirements

FILE NAME	DESCRIPTION	MEMORY REQUIRED
PVM00	Pre-driver (this is a small subroutine that resides in the Table II area in RTE-IVB or the subroutine area in RTE-MIII)	260 bytes
DVM00	Basic interface driver (supports all teleprinter like devices) (subroutine PVM00 is also required)	2640 bytes
	a. Driver memory requirement	64 bytes
	b. Table space for each terminal	
DDV05	Device driver for full screen mode and status reporting support of 262x, 263x, and 264x terminals (does not include support of cartridge tape units or auxiliary printer with 264x terminals) (DVM00 and its table space for each terminal is also required)	440 bytes
	a. Driver memory requirement	8 bytes*
	b. Table space for each terminal	
DDV12	Device driver for support of HP 7310A or 2631A/B Printers or 2635A/B Printing Terminal used as printer only (DVM00 and its table space for each terminal is also required).	320 bytes
	a. Driver memory requirement	6 bytes*
	b. Table space for each printer	

*NOTE: If either of two different devices may be connected to a particular multiplexer port, the table space allocated to that port should be the maximum table space required for either device.

connector kit and a customer-fabricated cable or through the cable supplied with the 12828A Multiplexer Panel and additional multiplexer panel-to-terminal cables. Then integrate the interface and appropriate supporting software into the operating system.

Ordering information

12792A 8-Channel Asynchronous Multiplexer Subsystem

The 12792A Subsystem includes:

- 5061-3428 8-channel Multiplexer Interface.
- 12792-80001 Firmware ROM.
- 5061-3467 80-pin connector kit.
- 12792-90001 Installation and Reference Manual.
- 12792-90002 Multiplexer Subsystem User's Manual.
- 12792-90003 Multiplexer Subsystem Configuration Guide.
- 12792-90004 Multiplexer Subsystem Numbering Catalog.
- Standard multiplexer software and diagnostics on Mini cartridges. Installation of multiplexer software into a new or existing system must be accomplished via a 264x+007, 032 Terminal with Cartridge Tape Units interfaced via a 12966A+001 Buffered Asynchronous Interface card.

Accessory connection panel

The 12828A RS-232-C Multiplexer Panel is recommended for convenient connection of devices to the 12792A subsystem. For more information on the 12828A and device-to-panel connection cables used with it, see the 12828A data sheet.



RS-232-C Multiplexer Panel

product number 12828A

The 12828A RS-232-C Multiplexer Panel provides a convenient means of connecting up to eight RS-232C compatible devices to the 12792A 8-channel Asynchronous Multiplexer Subsystem through standard EIA 25-pin "Cinch" connectors.

Features

- Convenient connection for up to 8 devices
- Design for rack mounted or stand-alone use
- Standard EIA connectors
- Transient suppression on Transmit, Receive, and Signal Ground lines for each channel
- Operation up to 91m/300ft from multiplexer interface

Functional specifications

Connectors

Multiplexer connection: One 36-pin connector for cable from multiplexer.

Device connection: Eight 25-pin EIA connectors.

Terminal connector pin assignments:

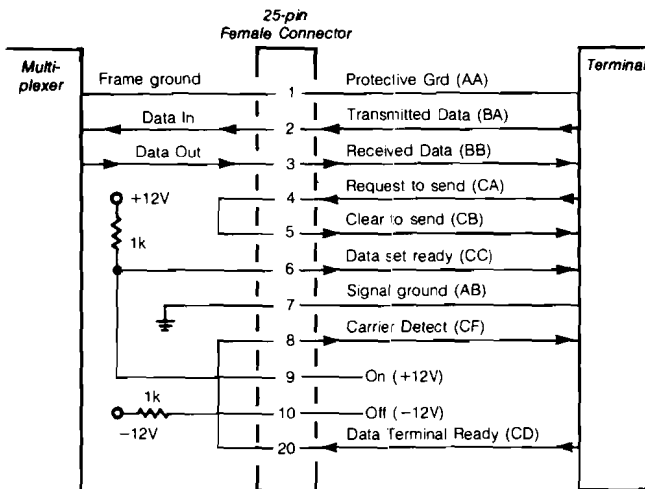

Mounting and connection

Mounting: The multiplexer panel may be rack mounted using included hardware or it may be used standing up on its own rubber feet on a desk, table, or other suitable surface.

Dimensions: 21.6cm/8.5in long by 8.9cm/3.5in high by 2.54cm/1in deep.

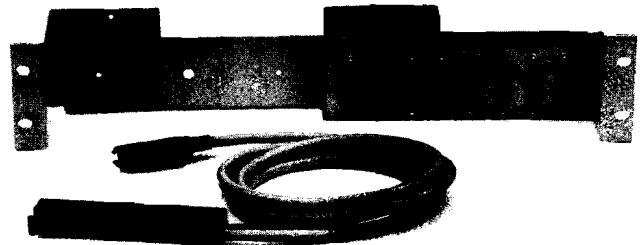

Connection: After installation of the 12792A Multiplexer in the computer, the interface cable supplied with the multiplexer panel should be connected between the multiplexer and the panel. Optionally, customer-fabricated cables can be used to extend the panel distance from the multiplexer to the panel to as much as 91 metres (300 ft). RS-232-C devices may then be connected to the panel with appropriate cabling (see Ordering information for device connecting cables).

Ordering information

12828A RS-232-C Multiplexer Panel

The 12828A Multiplexer Panel includes:

1. 12828-60001 RS-232-C Multiplexer Panel.
2. 12828-00004 Rack mounting bracket (NOTE: This item accommodates two 12828-60001 Multiplexer Panels.)
3. 12828-60002 3m/10ft Interface cable.
4. 12828-60003 Connector Kit for user-fabricated extension cable.
5. 12828-90001 Installation and Service Manual.

Device connecting cables

NOTE: 2631A +040 or Standard 2631B Printer or Standard 2635A/B Printing Terminal includes cable suitable for connection to the 12828A Multiplexer Panel.

13232A,M,N,Y	4.5m/15ft cable 264x Terminal to 12828A panel
13222M,N,Y	5m/17ft cable, 262x Terminal to 12828A panel.
30062B*	7.6m/25ft cable, modem to 12828A panel.
30062B+001*	15.2m/50ft cable, modem to 12828A panel.
30062C*	7.6m/25ft Extension cable.
30062C+001*	15.2m/50ft Extension cable.

* Not recommended for use in electrically noisy environment.



Asynchronous multiplexer subsystem software package for HP 1000 M/E/F-Series Computers

product number 91731A

The 91731A is a software support package for multiplexed terminal communication between an HP 1000 Computer System operating under RTE-MIII or RTE-IV/IVB and Hewlett-Packard CRT Display and printing terminals, using the 12920B 16-channel Asynchronous Multiplexer interface.

Features

- Supports up to two 12920B multiplexer interfaces, up to 16 channels per 12920B
- Program development and/or application program execution on RTE-IV/IVB systems
- Application program execution on RTE-MIII systems
- Support for 2621A/P, 2631A/B, 2635A/B, 2640B, 2645A, 2648A, 2649B, and 2649C terminals and Bell type 103A2 and 212A Data Sets and Vadic VA3400 modems
- Block mode data transfer capability
- Hardwired or full-duplex modem communication support
- Support for 2645A/48A/49B/49C Mini cartridge tape units and/or auxiliary printers
- Individually programmable channel characteristics
- Split speed operation with 264xA/B terminals
- Defined subsystem performance characteristics

Functional description

The 91731A multiplexer software supports up to 32 HP terminals asynchronously, at speeds up to 2400 bps. The software is designed to provide great flexibility in configuring a terminal network on an HP 1000 Computer System.

Data transfer configurations

Character mode transfer configuration uses the DVS00 software module of the 91731A package, with the following characteristics:

- These default conditions for ease of use:
 - 110 baud operation
 - 8-bit standard ASCII input and output
 - No parity
 - Echoplex "on"
 - Hardwired operation (no modems)
- Support for either one or two 12920B Multiplexer interfaces (16 or 32 ports)
- Support for teletype protocol
- Auto speed detection for terminals operating at unknown speeds within terminal speed range
- Terminal speed range includes 110, 150, 300, 600, 1200, and 2400 baud
- Support for pause/restart toggling on output by depressing any terminal key
- Special processing on output for the left arrow (←)

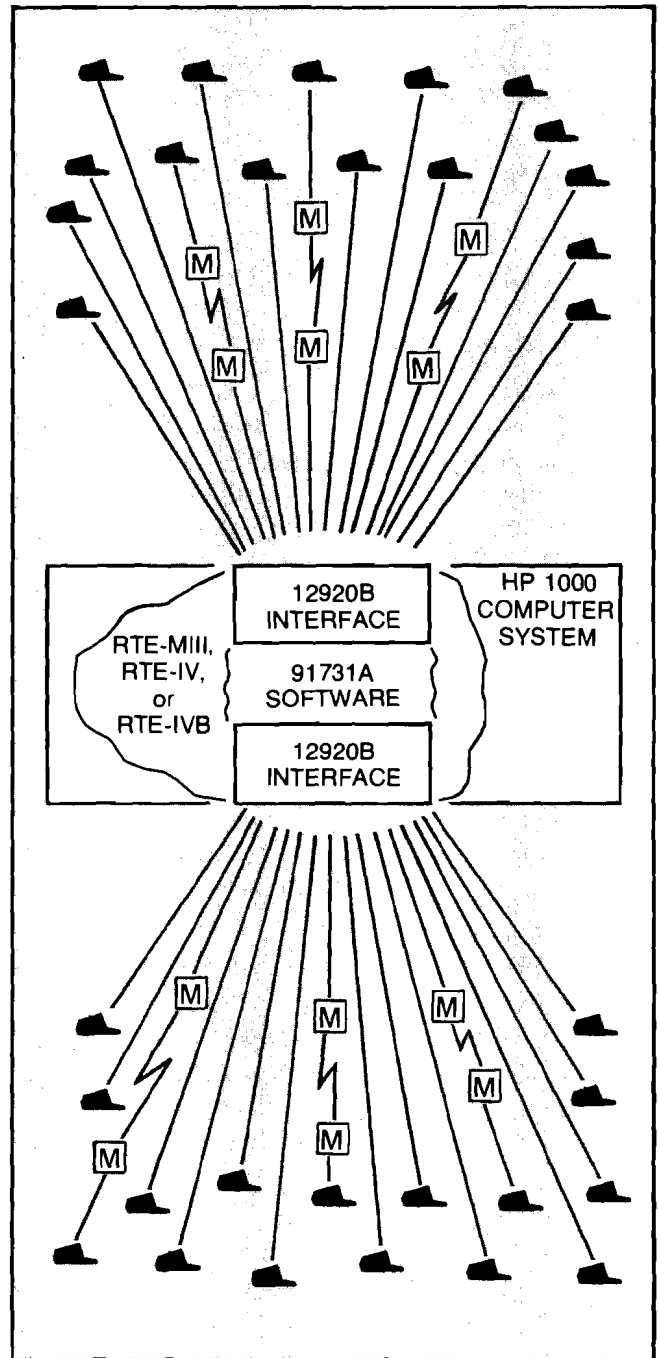

HP 91731A Asynchronous Multiplexer Subsystem Software supports up to two HP 12920B Asynchronous Multiplexer Interfaces, up to 16 terminals per interface, either hardwired-connected or modem **M** connected.

- Special character processing on input for line feed, carriage return, CNTL-A/H/D/Y, backspace, and rubout. Any keystroke will schedule a program designated during system generation.

Block and character mode transfer configuration uses the DVS00 and LDVR5 software modules of the 91731A, with the following characteristics:

- Support for all capabilities of the character mode transfer configuration, listed in the previous paragraph
- Keyboard input in either block or character mode for 2621A/P, 2640B, 2645A, and 2648A CRT Display terminals, character mode only input to 2635A terminal
- Computer-enabled block mode read from display on, 2621/2645/2648/2649B/2649C (simulates ENTER keystroke)
- Supports 2631A +040 or 2631B Printer and 2635A/B Printing terminal with keyboard.

Block and character mode transfer configuration with support for Mini cartridge I/O and auxiliary printers uses the DVS00 module and a larger LDVR5 software module of the 91731A package to provide the following characteristics:

- All characteristics previously listed for character mode and block and character mode transfer configurations
- Write EOF, forward/backspace one record or file, or locate a specific file on Mini cartridge unit 1 or 2 on a suitably equipped 2645A/2648A
- Write to/read from Mini cartridge unit 1 or 2 on suitably equipped 2645A/2648A
- Print output on 2631A +240 or 13246A/B Auxiliary printer of a suitably equipped 2645A/2648A Display terminal.

Modem support

The 91731A software supports Bell type 103A2 and 212A Data sets and Vadic Corporation VA3400 modems.

The 91731A supports the auto answer feature of these full-duplex modems as well as providing recovery after a modem link failure. If the link goes down during terminal operation, the 91731A software will detect the failure, perform a buffer flush operation, and notify the calling program, and the operator, if desired.

Character set

With block mode configuration, the 91731A software will pass the extended character sets and display enhancements of the 264x series CRT Display terminals, but these are not recognized by the operating system or program development software. Only upper-case ASCII characters and numerals are usable in the operating system, file manager, or in program statements, names, and labels. Other characters, such as lower case, result in an error message. However, this does not exclude the entry or retrieval of other characters in data files, their use in program documentation comments, or use of lower case characters in editor commands and/or edit files.

Channel control

The 91731A software lets the user programmatically specify baud and time-out rates individually for each channel. Split speed operation, (different input and output speeds on a single channel) is also supported with 264xA/B terminals.

Functional specifications

Compatibility

Operating system: 92064A RTE-M system (RTE-MIII configuration requiring at least 128k bytes of memory) for application program execution and 92067A RTE-IV or 92068A RTE-IVB system for both application program execution and program preparation.

Hardware: 12920B Asynchronous Multiplexer Interface and cables, 12620A privileged interrupt fence, and any of the following Hewlett-Packard terminals:

TERMINAL	CABLE	RECOMMENDED TERMINAL STRAPS
2621A Interactive Terminal	13222N	bcgHxz Etx
2621P Interactive Terminal	13222N	bcgHxz Etx
2631A +040 Printer	*	—
2631B Printer	*	—
2635A/B Printing Terminal	*	—
2640B CRT Display Terminal	13232A	A,B,E-H and J-Z
2645A Display Station	13232A	closed, C and D as
2648A Graphics Terminal	13232A	desired
2649B OEM Block or character mode terminal	13232A	
2649C OEM Graphics terminal	13232A	

*Cable for 2631A +040, 2631B or 2635A/B is supplied with the terminal.

NOTE: Data cannot be transferred directly from the system to the printer of the 2621P. Data must first be written to the 2621P display, then dumped to the printer.

Exclusion: The 91731A software does not support HP 307xA/B Data Capture Terminals.

Compatibility with other HP 1000 Communications Software: 91731A software cannot be run concurrently with other software utilizing the privileged interrupt capability of RTE, due to the likelihood of such use resulting in occurrence of line errors.

Multiplexer system capacity

Multiplexer interfaces and terminals: The 91731A software can support up to two 12920B Asynchronous Multiplexer Interfaces, up to 16 terminals per interface, or a maximum of 32 channels with two 12920B interfaces.

Maximum rate per terminal: 2400 bps.

Maximum composite data rate: The maximum composite data rate that can be handled by the 91731A software using 100% of computer time with non-fault control memory, no direct memory access transfers in progress, and no other system activity, depends upon the computer configuration, as follows. This includes all terminals connected to one or two 12920B interfaces:

HP 1000 Computer:	Series M	Series E	Series E/F
Memory type:	Std perf.	Std perf.	High perf.
Max. composite rate:	5900 bps	10,000 bps*	12,000 bps*

*Fault control memory will reduce the maximum composite rate slightly in E and F-Series computers.

Operational recommendations: Operation near the maximum composite data rate is not recommended. Attempt to exceed the maximum composite data rate, such as with 32 terminals all simultaneously entering block data at 600 bps, will result in data loss. Input data loss can be eliminated by restricting terminal operation to character mode only or greatly reduced by using split speed operation. Although character mode precludes use of Mini cartridge I/O, the data integrity guaranteed by its use may be justified in applications requiring concurrent activity of many terminals.

NOTE: *Because operation is asynchronous, no data loss will occur on output to terminals. The result on output of attempting to exceed the maximum composite rate will be a slow-down in the actual data rate, which may not be uniformly distributed among the various terminals.*

Capabilities not supported

- The system console
- Current loop operation
- Half duplex operation
- User-written logical drivers
- Parity on binary data when using Mini cartridges
- Terminals not listed in the Compatibility section
- Power fail recovery after power fail
- Dialing on 801 Auto Calling Unit (although 12920B interface is capable of that)
- Plotting or reverse line feed on 13349A auxiliary line printer for 264x terminal

Minimum system requirements

Minimum system requirements are the same as for the RTE-IV/IVB system or the RTE-MIII (mapped, multi-user configuration of RTE-M) system plus a 12920B Asynchronous Multiplexer Interface, cables, and connector panel, a 12620A privileged interrupt fence, a 12539C Time Base Generator, and one or more of the Hewlett-Packard terminals listed in the compatibility section.

Approximate memory requirements by system configuration

	Up to 16 Ports (1 x 12920B)	Up to 32 Ports (2 x 12920B)
Character mode only:	3820 bytes	4040 bytes
Block or Character Mode Display only:	5920 bytes	6500 bytes
Block or Character Mode with Mini cartridge and Auxiliary Printer Support:	6920 bytes	7500 bytes
Additional EQT table storage per configured channel:	52 bytes	52 bytes

Ordering information

91731A+020 Asynchronous Multiplexer Subsystem Software Package

The 91731A+020 package includes:

1. Software on Mini cartridge.
2. User's guide (91731-90001).
3. 91731A Software numbering catalog (91731-90002).
4. Configuration guide (91731-90003).

Software support products available

91731T+020 Customer Support Service for 91731A software (updates on Mini cartridges)

91731V Central support for additional copy of 91731A

91731S+020 Software Subscription Service for 91731A software (updates on Mini cartridges)

91731Q Manual Update Service for 91731A software manuals



HEWLETT
PACKARD

HP 1000 M/E/F-Series 16-channel Asynchronous multiplexer

product number 12920B

The 12920B Asynchronous multiplexer provides a convenient way to interface up to 16 low speed (up to 2400 baud) asynchronous data communications devices (terminals or data sets) to HP 1000 M/E/F-Series computers. The multiplexer can be used with a combination of terminals operating hardwired and/or via half-duplex or full-duplex modems.

Features

- Inexpensive multi-port interface for up to 16 devices
- EIA RS-232-C and CCITT V.24 compatibility
- Programmable data rates
- Programmable character length from 5 to 12 bits
- Programmable speed detection for up to six standard rates plus detection for the IBM 2741*
- Automatic break detection
- Automatic answering
- Character assembly performed by hardware
- Hardware compatibility with up to eight Bell type 801 automatic calling units*
- Programmable split speed operation
- Full duplex, half duplex*, or echoplex transmission
- Programmable parity generation and checking

*Identifies feature not supported by 91731A or any other Hewlett-Packard software.

Functional description

The 12920B Asynchronous Multiplexer provides multiplexed terminal support for asynchronous low speed (up to 2400 baud) terminals hardwired to the multiplexer or connected by modems. Multiplexer hardware is capable of operating at programmable data rates of up to 2400 bps on any given channel.

The 12920B Asynchronous multiplexer provides three interface cards, cables, and a connector panel. For devices hardwired directly to the multiplexer, the computer simulates a data set, so any terminal that can work directly with a data set will work directly with the multiplexer. Dialers, terminals, and data sets may be intermixed, with the restriction that each dialer uses two of the 16 ports provided by the multiplexer.

For data set applications, the multiplexer provides the signals needed to operate up to 16 Bell type 103A2 or 212A Data Sets or Vadic Corporation VA3400 full-duplex modems. Any combination of 16 compatible modems and terminals may be connected and operated simultaneously. With 12920B option 001 an additional interface card increases the number of control and status lines so that half-duplex Bell type 202 Data Sets with optional reverse channels can also be connected and operated, but option 001 is not software supported by Hewlett-Packard.

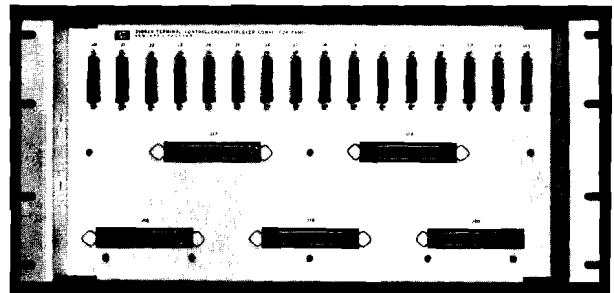
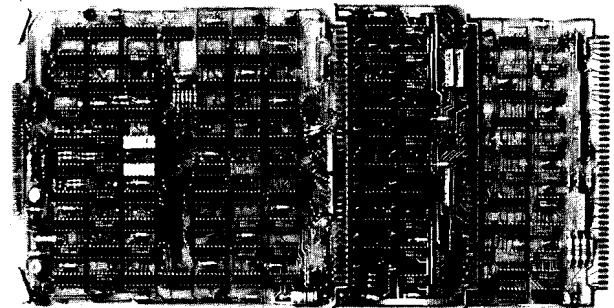

Functional specifications

Capacity

16 channels for transmit and 16 for receive with external data sets of terminals. (Automatic calling units use two channels each.) Five channels for receive only are internal to interface for diagnostic purposes.

Communication

Bit transfer rate (Baud): 57 to 2400 bits/second programmable.

Character length: 5 to 12 bits/character, programmable. Character size is the total number of bits (start, plus data, plus stop bits).

Mode of communication: Asynchronous bit serial.

Interrupt trigger: Leading, trailing, or both edges of the status line signal, program selectable.

Data lines: Two data lines to each of 16 channels.
Data in: Received data (BB).
Data out: Transmitted data (BA).

Control lines from first control card: These two lines to each of 16 channels.

Command 1 (C1): Data terminal ready (CD).
Command 2 (C2): Request to send (CA).

Control lines from second (option 001) control card:

These two lines to each of 16 channels.
Control 1 (C1): Supervisory transmit (SA).
Control 2 (C2): Data signal rate selector (CH/CI).

Status lines from first control card: These two lines to each of 16 channels.

Status 1 (S1): Data set ready (CC).

Status 2 (S2): Received line signal detector (CF).

Status lines from second (option 001) control card:

These two lines to each of 16 channels.

Status 1 (S1): Supervisory receive (SB).

Status 2 (S2): Received line signal detector (CF).

Multiplexer panel connector pin assignments

Even Port Pin No.	Odd Port Pin No.	Multiplexer Designation	EIA Designation
2	2	Data in	(BB) Received data
3	3	Data out	(BA) Transmitted data
4 & 5	4 & 5	Status 2	(CF) Signal detector
6	6	Command 1	(CD) Data terminal ready
7	7	Command return	(AB) Common return
8	8	Command 2	(CA) Request to send
9	9	+12 volts	
11	11	Status 1*	(SB) Supervisory receive
12	12	Command 1*	(SA) Supervisory transmit
13†		Status 2†	(CF) Signal detector†
14†		Status 1†	(CC) Data set ready†
15†		Command 2†	(CA) Request to send†
16†		Command 1†	(SA) Supervisory transmit†
17**	17**	-12 volts**	
18†		Status 2	(CB) Clear to send†
20	20	Status 1	(CC) Data set ready
22	22	Status 2*	(CB) Clear to send
23	23	Command 2*	(CH) Frequency select

*Identifies signals available only with 12920B option 001, which provides a second control card for operation with Bell type 202A Data Set.

†Identifies non-standard pins and signals on the connectors for Even ports, which are provided for operation with Bell type 801 Automatic calling units. These signals are strapped with the next higher port.

**WARNING: -12 volts on pin 17 of multiplexer panel connectors will destroy the receiver timing circuit of 264xA/B terminals connected using older 13232N cables. This voltage may also present a danger to other terminals unless the cables shown in the connection diagram of Figure 1 are used only with the terminals they are shown connected to.

Logic levels at data set connectors*

Command and status lines:

Logic 1 (high): More positive than +3V (on).

Logic 0 (low): More negative than -3V (off).

Data lines:

Logic 1 (low): More negative than -3V (mark).

Logic 0 (high): More positive than +3V (space).

*Refer to EIA standard RS-232-C.

Configuration information

Computer compatibility: The 12920B is hardware compatible with all HP 1000 Computers, except the 2105A.

Racking compatibility: The 12920B connector panel can be mounted only in 29402B upright cabinets or in HP 1000 Systems in upright cabinet configuration.

Computer I/O Channels required: The 12920B requires 3 computer I/O channels; 12920B option 001 requires one additional I/O channel.

Software support: Operation of up to two 12920B interfaces in RTE-M (RTE-MIII configuration) and RTE-IV/IVB systems is supported by the 91731A Asynchronous Multiplexer Subsystem Software package. However, the 91731A package does not support all 12920B functions and capabilities; support is limited to that described in the 91731A data sheet. In addition, a 12920B diagnostic is available in the 24396A-F diagnostic library.

Connecting cables: To complete installation, cables will be required for data sets or automatic dialers connected to the

12920B. In most instances, the EIA standard cable supplied with a terminal equipped to connect to a modem will connect directly, or through an extension cable, into the multiplexer connector panel.

Panel connectors: The 16 connectors on the multiplexer connector panel are standard EIA 232, 25 pin "cinch" connectors.

Installation: To install, plug the two data interface cards into adjacent slots in the computer I/O backplane and the control interface into a third I/O slot, adjacent to the data interfaces. If used, the 12920B option 001 second control card plugs into a fourth I/O slot. Mount the connector panel in the rear of the 29402B cabinet housing the computer (within reach of the 3.6m (12 ft) interface-to-connector panel cables), connect the data and control cable assemblies between the interface cards and the connector panel. Then integrate the asynchronous multiplexer and 91731A software into the computer's operating system and connect terminals and/or modems to it (see Figure 1).

Current required from computer power supply:

Supply voltages:	+5V	-2V	+12V	-12V
Standard 12920B	5.53A	0.258A	0.241A	0.477A
Add'l control card:	1.44A	0.102A	0.156A	0.236A

Physical characteristics

Connector panel height

22.2 cm (8-3/4 in).

Weight

Standard 12920B: 3.7 kg (8 lb).

Add'l control card: 270 g (10 oz).

Ordering information

12920B 16-channel Asynchronous multiplexer

The 12920B Multiplexer includes:

1. 12920-60001 Data interface card, upper select code.
2. 12920-60002 Data interface card, lower select code.
3. 12921-60003 3.6m (12 ft) Data cable assembly.
4. 12922-60001 Control interface card.
5. 12922-60003 3.6m (12 ft) Control cable assembly.
6. 30062-60002 Connector panel assembly.
7. Panel mounting hardware.
8. 30062-60017 Connector panel.
9. 30062-60016 Multiplexer test assembly.
10. 12920-90007 Multiplexer reference and application manual.

12920B option 001

12920B option 001 (not supported by 91731A software) adds:

1. 12922-60001 Control interface card (second control card).
2. 12922-60003 3.6m (12 ft) Control cable assembly.

Accessory cables available

For data sets:	30062B	7.6m (25 ft).
	30062B+001	15.2m (50 ft).
For automatic calling units:	30062-60005	7.6m (25 ft).
	30062-60008	15.2m (50 ft).
Extender cables:	30062C	7.6m (25 ft).
	30062C+001	15.2m (50 ft).
	30062C+002	30.4m (100 ft).

Typical asynchronous multiplexer connections

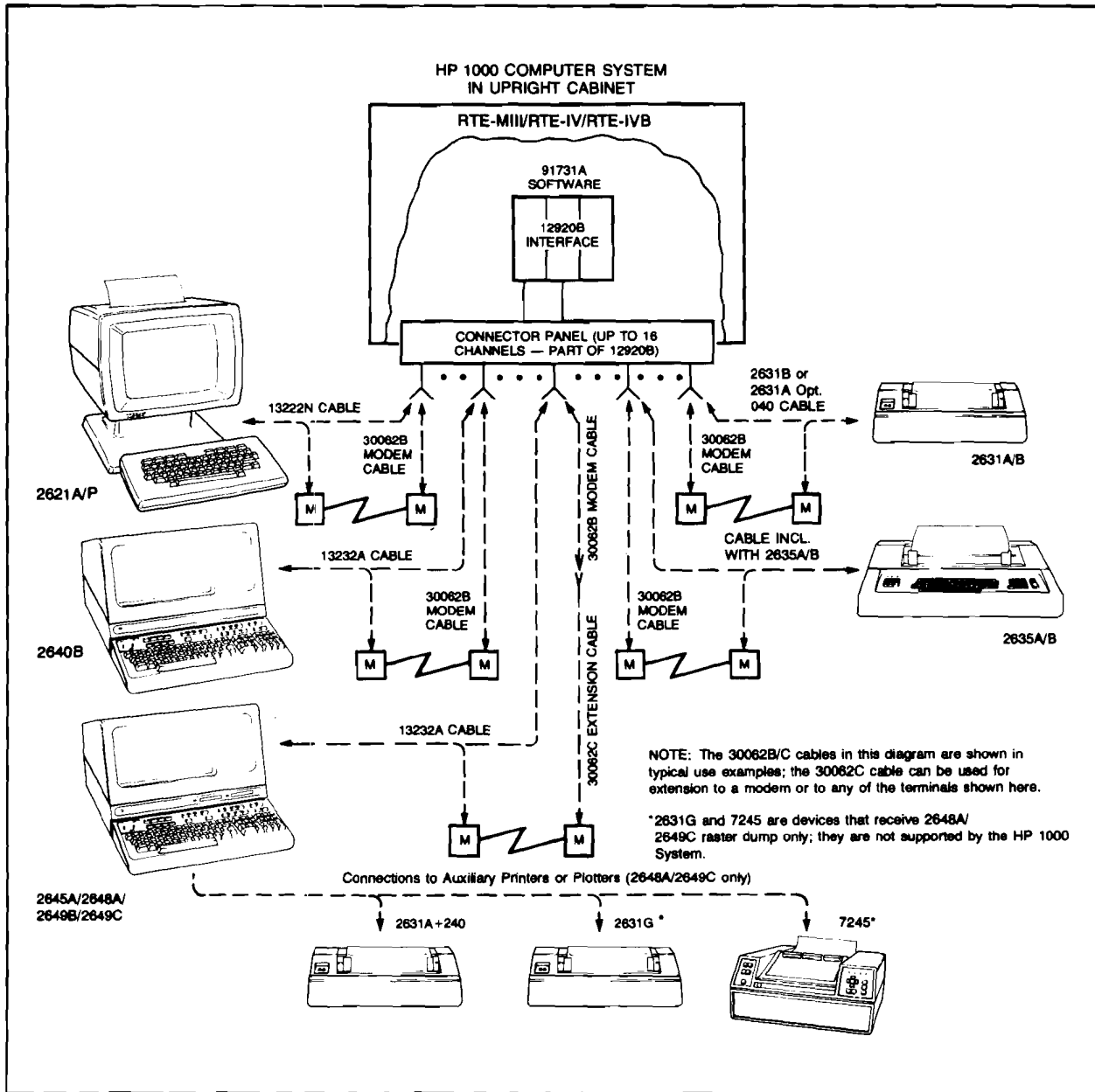

Figure 1. Typical asynchronous multiplexer connections



HP 1000 L-Series Asynchronous Serial Interface

product number 12005A

The 12005A Asynchronous Serial Interface provides for connection of EIA Standard RS-232-C, RS-422/423, or RS-449 compatible devices to HP 1000 L-Series Computers or Systems. The connection can be either local via an optional hardwire cable, or remote, via Bell 103 Data Set or equivalent modem. Optional cables are available for hardwire connection to HP 2621A/P Interactive Terminals, HP 2635A/B Printing Terminals, or HP 264x Display Terminals. The 12005A and associated drivers provided with the 92070A RTE-L operating system support all aspects of functioning of the aforementioned terminals in a terminal-per-interface mode. This includes support of optional Mini cartridge I/O on the 264x terminals.

Features

- EIA RS-232-C, RS-422, RS-423, and RS-449 compatibility
- Fifteen selectable data transfer rates from 50 to 9600 baud, plus externally-clocked rates to 56,000 baud
- Choice of half-duplex or full-duplex operation, or echoplex operation with secondary data channel
- Built-in DMA capability for optimum I/O efficiency
- Selectable special character recognition capability for termination of indeterminate length DMA transfers by an End of Transmission character
- Virtual control panel support
- Built-in framing error, overrun error, and parity error checking
- Hardware break detection
- Voltage level and current loop outputs
- I/O driver support with 92070A RTE-L operating system

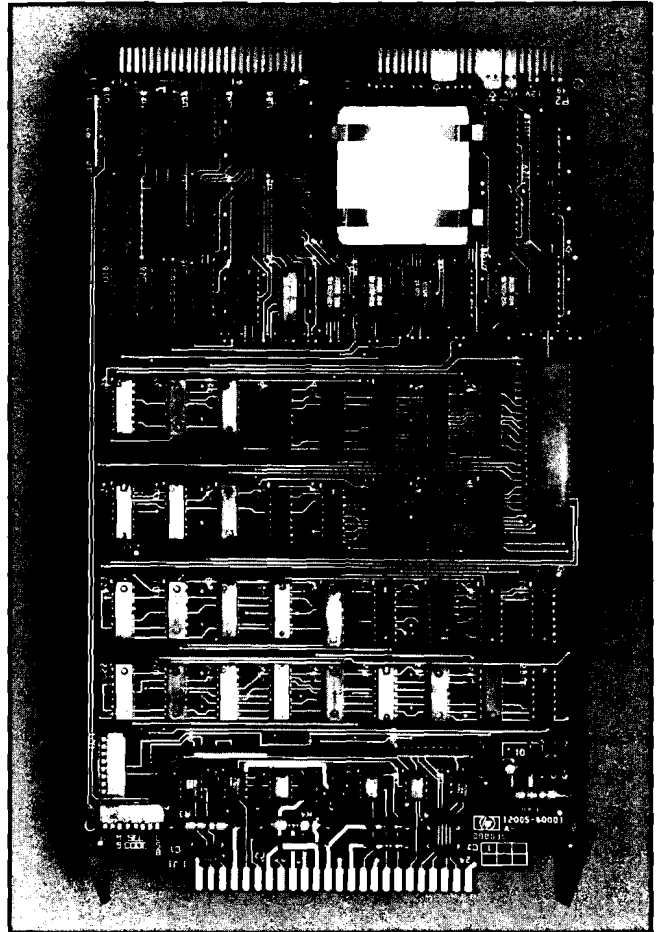

Functional specifications

Formats, parity, and format control

Data codes: 7-bit ASCII or 8-bit binary.

Serial data transfer format: Each 7-bit or 8-bit data code is preceded by a start bit, accompanied by an odd or even parity bit, and followed by one or two stop bits.

Parity selection: Odd or even parity is selected by a switch on the interface.

Stop bit selection: A switch on the interface selects either one or two stop bits.

EIA compliance

The 12005A interface complies with EIA Standards RS-232-C, RS-422, RS-423, and RS-449, and equivalent international standards, as summarized in Tables 1 and 2.

Table 1. Maximum cable lengths and data rates by EIA standard

EIA Std	RS-232-C	RS-422	RS-423	RS-449
Driver-Receiver Type	Single-Ended	Differential	Single-Ended	Both
Max. Cable Length	15.24 metres (50 ft)	12.19 metres (40 ft) at 10M baud 1219 metres (4000 ft) at 100k baud	12.19 metres (40 ft) at 100k baud 1219 metres (4000 ft) at 1k baud	60.96 metres (200 ft) at 2M baud
Max. Data Rate	20k baud	10M baud at 12.19 metres (40 ft)	100k baud at 12.19 metres (40 ft)	2M baud

Table 2. RS-449/RS-232 Data signal equivalency

Ext. Dir. from I/O	RS-449	Signals	RS-232-C	Signals
	SG	Signal Ground	AA	Protective Ground
	SC	Send Common	SB	Signal Ground
	RC	Receive Common		
Out	RS*	Request to Send	CA	Request to Send
In	CS*	Clear to Send	CB	Clear to Send
In	DM*	Data Mode	CC	Data Set Ready
Out	TR	Terminal Ready	CD	Data Terminal Ready
In	IC*	Incoming Call	CE	Ring Indicator
In	RR*	Receiver Ready	CF	Detector Line Signal
Out	SD*	Send Data	BA	Transmitted Data
In	RD*	Receive Data	BB	Received Data
Out	SSD	Secondary Send Data	SBA	Secondary Transmitted Data
In	SRD*	Secondary Receive Data	SBB	Secondary Received Data

* Differential driver or receiver is used on this signal, which is available as a balanced or unbalanced signal. NOTE, however, that all 12005A cable options are wired to use the unbalanced signals for compatibility with the HP 26xx terminals that are used with this interface.

Transfer rates

Interface-clocked rates: 50, 75, 110, 134.5, 150, 300, 600, 900, 1200, 1800, 2400, 3600, 4800, 7200, and 9600 baud (bits/second), selected by four switches on the interface.

Externally-clocked rate: Up to 56,000 baud (bits/second), as determined by the terminal or other serial device interfaced by the 12005A.

Character buffering

Two characters.

Teleprinter interface

A 20mA current loop interface, designed to run at 9600 baud (bits/second) is provided for interfacing to teleprinters; connection to this interface requires a user-fabricated cable.

Virtual control panel support

The 12005A interface can be set to support a terminal which will function as the Virtual Control Panel of the computer.

Direct Memory Access (DMA) operation

DMA accessibility: The 12005A can access memory under control of its I/O master processor, regardless of how many other interfaces in the system are also accessing memory via DMA.

Termination of indeterminate length transfers: A special character recognition capability can be set up under program control so that a DMA transfer terminates automatically when a specified character is encountered. In this way, the receipt of a carriage return, for example, can be used to terminate block transfers from terminals regardless of the length of the block being transferred.

Break detection

Hardware break detection.

Configuration information

Computer and system compatibility: The 12005A Asynchronous Serial Interface is compatible with all HP 1000 L-Series Computers and Systems.

Connector compatibility: The 12005A printed circuit cable connector is pin-compatible with the 12531C/D interface used in HP 1000 M/E/F-Series Computers, but not with the 12966A interface used in those computers.

Software support: The 12005A interface is supported by RTE-L interface driver ID.00. Use of Hewlett-Packard 26xxA terminals with the 12005A interface is supported by RTE-L device drivers DD.00 (keyboard-display I/O) and D.20, (mini cartridge I/O) which work with interface driver ID.00.

Modem capability: The 12005A interface with supporting RTE-L driver ID.00 is compatible with Bell Type 103 Data Sets and equivalent modems.

Diagnostic support: A diagnostic and a test connector for the 12005A interface are provided in the 24397A Diagnostic Package.

Current required from computer power supply

1.6A(+5V), 0.145A(+12V), 0.11A(-12V).

Installation: Set baud rate switches; set Virtual Control Panel switch if used with a Virtual Control Panel terminal; select even or odd parity and desired number of stop bits; set I/O address on select code switches; turn off the computer; plug the interface into the computer backplane; connect the data cable to the terminal or modem; and integrate the interface driver into the operating system if that has not been accomplished previously.

NOTE: The select code switch I/O address setting is independent of the interface card's position in the computer backplane.

Physical characteristics

Dimensions

289 mm (11.38 in) long by 172 mm (6.75 in) wide by 1.6 mm (0.063 in) board thickness, with 10.2 mm (0.4 in) top-of-board parts clearance and 5.1 mm (0.2 in) beneath-board clearance.

Weight

795 grams (28 oz) with option 001, 002, or 003 cable.

Ordering information

12005A Asynchronous Serial Interface

The 12005A Asynchronous Serial Interface includes:

1. Asynchronous serial interface card (12005-60001).
2. Reference manual (12005-90001).

12005A connection Options

- 001: 15.2m (50 ft) cable (12005-60002) for connection to 2621A/P Interactive Terminal.
- 002: 15.2m (50 ft) cable (12005-60003) for connection to 2635A/B Printing Terminal.
- 003: 7.6m (25 ft) cable (12005-60004) for connection to U.S. modem.
- 004: 48 pin connector kit for user-fabricated cable.
- 005: 5m (17 ft) cable (12005-60005) for connection to 264x Display terminal.



HP 1000 M/E/F-Series Character mode terminal interfaces

product numbers 12531C, 12531D, and 12880A

The 12531C, 12531D, and 12880A interfaces provide for local or modem connection of printing or non-cartridge tape CRT terminals to HP 1000 M/E/F-Series Computer Systems.

Features

- EIA RS-232-C and CCITT V.24 compatibility
- Simplex, half duplex, or echoplex operation
- Jumper-selectable data transfer rates to 2400 bits/second with 2 stop bits

Functional specifications

Application

12531C: The 12531C is for interfacing HP 2752A/2754B or equivalent ASR 33/35 type Teleprinters to HP 1000 computers. Optionally, the 12531C can also interface Bell type 103 or equivalent data sets, operated in manual mode only.

12531D: The 12531D is for interfacing a variety of terminal devices to an HP 1000 computer or system, either locally or via Bell type 103A data set or equivalent modem operating in manual mode.

12880A: The 12880A is compatible with 2621A/P, 2640B, 2645A, or 2648A Display terminals without cartridge tape or auxiliary printer capabilities for local connection to an HP 1000 Computer system. It is designed to function at the data rate set by the interfaced terminal. However, HP recommends use of the 12966A Buffered Asynchronous Interface for these terminals, because it substantially improves system performance.

Interface level

12531C or 12531D: 20 mA or EIA/CCITT.

12880A: EIA/CCITT.

Jumper-selectable baud rates with internal clock

12531C: 110, 220, 440, 880, and 1760 bits/second.

12531D: 150, 300, 600, 1200, and 2400 bits/second.

Maximum baud rate with external clock from terminal

12531C: 2400 bits/second.

12531D or 12880A: 9600 bits/second.

Character size, stop bits, and buffering

8-bit character with one or two stop bits. Each interface buffers a single character at a time for transfer to/from the computer.

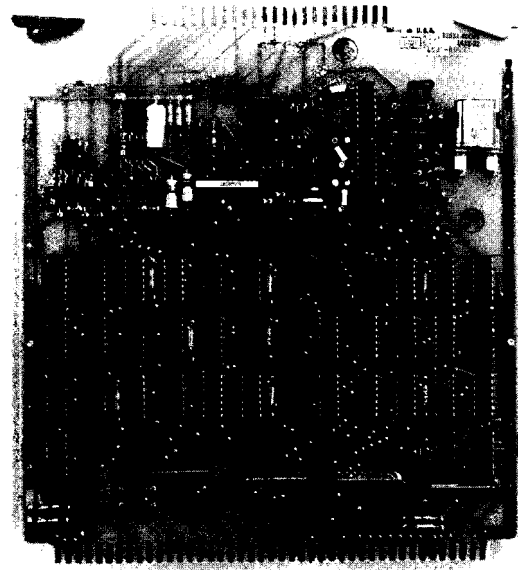

12531D Terminal interface

Modem interface capability

12531C and 12531D: Bell type 103 or equivalent, manual only.

12880A: Local interfacing only, no modem capability

Configuration information

Compatibility: The 12531C, 12531D, and 12880A terminal interfaces and supporting software are compatible with 2105, 2108, 2109, 2111, 2112, 2113, and 2117 computers with BCS, RTE-B, RTE-C, RTE-M, RTE-II, RTE-III, RTE-IV/IVB operating system. No other operating system environment is supported.

Computer I/O channels required: One.

Approximate memory required: 710 bytes for each terminal interface in BCS system; 1220 bytes for all terminal interfaces in RTE-B/C/M/II/III/IV/IVB system, which also serves the punched tape reader and tape punch subsystems.

Software support: RTE driver DVR00, which is included in the 92001B RTE-II, 92067A RTE-IV, 92068A RTE-IVB, and 92064A RTE-M operating systems, is used by the 12531C, 12531D, and 12880A terminal interfaces.

Diagnostic support: Diagnostics for the 12531C, 12531D, and 12880A interfaces are provided in the 24396A-F Diagnostic Library.

Installation: To install, plug the terminal interface into the computer I/O backplane, connect the interface cable to the terminal or modem, and integrate the interface into the operating system.

Current required from computer power supply:

	+5V	-2V	+12V	-12V
12531C:	0.76A	0.05A	0.08A	0.1A
12531D:	0.76A	0.05A	0.24A	0.01A
12880A:	0.86A	0.05A	0.24A	0.01A

Ordering Information

12531C Teleprinter interface

The 12531C Teleprinter interface includes:

1. 12531-60022 Teleprinter interface card.
2. 12531-90033 Interface manual.

12531C Options

- 001: Adds 12531-60021 7.6m (25 ft) EIA terminal cable.
002: Adds 12531-60024 7.6m (25 ft) Data set cable.

12531D Terminal interface

The 12531D Terminal interface includes:

1. 12531-60025 Terminal interface card.
2. 12531-90038 Interface manual.

12531D Options

- 001: Adds 12531-60026 7.6m (25 ft) EIA terminal cable.
002: Adds 12531-60024 7.6m (25 ft) Data set cable.
004: Adds 02640-60058 15.2m (50 ft) HP 2640 CRT terminal cable.

12880A CRT Terminal interface

The 12880A CRT Terminal interface includes:

1. 12880-60001 Terminal interface card.
2. 12880-60003 15.2m (50 ft) EIA terminal cable.
3. 12880-90001 Interface manual.

12880A Option 001

12880A option 001 replaces the 12880-60003 EIA terminal cable with the 02640-60058 15.2m (50 ft) HP 2640 CRT terminal cable.



HP 1000 M/E/F-Series Asynchronous terminal communications interfaces

product numbers 12966A, 12968A, and 12587B

The 12966A, 12968A, and 12587A interfaces provide for connection of Bell type 103 or type 202 data sets or equivalent modems to HP 1000 computers, offering three levels of capability and sophistication to the user. The 12966A is HP's most powerful point-to-point terminal interface and is supported under RTE-M/II/III/IV/IVB for local or modem interfacing of 2635A Printing terminals, 2621A/P, 2640B, 2645A, 2647A, 2648A, 2649B, 2649C, or 2649G Display terminals with or without Mini cartridge I/O and/or auxiliary printers, or 7221A Graphics Plotter to HP 1000 computers and systems.

Features

- EIA RS-232-C and CCITT V.24 compatibility
- Compatibility with Bell 103 and 202 data sets or equivalent
- Data set control implemented through software
- Simplex, half duplex, or echoplex operations with secondary data channel
- Selectable data rates to 9600 bits/second
- Multiple character buffering
- Special character recognition/interrupt capability with 256 byte special character memory (12966A only)
- Selectable character size, parity checking, and number of stop bits
- Hardware break detection (12966A and 12968A)

Functional descriptions

12966A Buffered asynchronous communications interface

The 12966A is the recommended point-to-point interface for 2621A/P, 2640B, 2645A, 2647A, 2648A, 2649B, 2649C, and 2649G Display terminals, with or without mini cartridge tape units or auxiliary printers, 2631A/B and 2635A/B Printing terminals, and 7221A/B/S Graphics Plotter on HP 1000 Computer Systems. Its buffering offers high performance when used with software driver DVR05 or DVA05 in RTE-M/II/IV/IVB based systems. The 12966A contains a 128 character buffer which supports block-mode data transfers for efficient use of computer time. Interface flags indicate buffer status, improving computer utilization by reducing the number of times an interrupt must be serviced. The 12966A also contains a special character recognition/interrupt capability with a 256 byte RAM special character memory. The special character memory gives the user the ability to specify up to 256 different special characters and cause an interrupt flag to be set whenever one of them is received. The interface operates at speeds to 9600 bps.

12968A Asynchronous communications interface

The 12968A offers the same speed capabilities as the 12966A, but has only a two-character buffer and no special character recognition/interrupt capability.

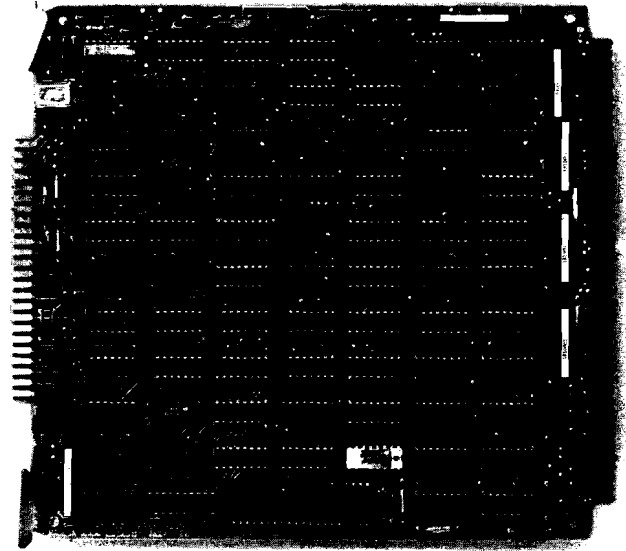

12966A Buffered asynchronous communications interface card

12587B Asynchronous communications interface

The 12587B is the simplest asynchronous communications interface Hewlett-Packard offers for use with Bell type 103 or type 202 data sets. It provides asynchronous communication at hardware jumper-selected, internally-clocked rates to 2400 bits/second or externally-clocked rates to 9600 bits/second. Character size, parity generation and checking, and number of stop bits are programmable. The 12587A conforms to EIA and CCITT specifications.

Functional specifications

Interface level

EIA OR CCITT

Jumper-selectable baud rates with internal clock

12966A and 12968A: 50, 75, 110, 134.5, 150, 300, 600, 900, 1200, 1800, 2400, 3600, 4800, 7200, 9600 bits/second.

12587B: 45, 50, 75, 110, 134.5, 150, 165, 200, 220, 300, 330, 440, 600, 880, 900, 1050, 1200, 1760, 2400 bits/second.

Program-selectable baud rates with internal clock

12966A and 12968A: Same as jumper-selectable baud rates, listed above.

12587B: Baud rates of the 12587B are not program selectable.

Maximum baud rate with external clock

9600 bits/second.

Programmable character size

12966A and 12968A: 5, 6, 7, or 8 bits.

12587B: Any size from 1 through 8 bits.

Stop bit selection

12966A and 12968A: 1, 1-1/2, or 2, program selectable.

12587B: 1 or 2, jumper selectable.

Programmable parity generation and checking

No parity, odd, or even.

Character buffering

12966A	12968A	12587B
128 char	2 char	1 char

Special character memory

256 characters in 12966A only.

Modem interface capability

12966A: interface and supporting DVA05 software driver are compatible with Bell type 103 Data Sets and Vadic VA3400 1200 bps modem.

12968A and 12587B: interfaces are hardware compatible with Bell type 103 and 202 Data sets, and provide a secondary data channel.

Break detection

12966A and 12968A: hardware break detection.

12587B: Software break detection with type 202 data set.

Data set signals provided

EIA Designation	12966A	12968A	12587B
Protective ground			(AA)
Transmitted data	(BA)	(BA)	(BA)
Received data	(BB)	(BB)	(BB)
Request to send	(CA)	(CA)	(CA)
Clear to send	(CB)	(CB)	(CB)
Data set ready	(CC)	(CC)	(CC)
Signal ground	(AB)	(AB)	(AB)
Received line signal detector	(CF)	(CF)	(CF)
Secondary received line	(SCF)*	(SCF)*	(SBA)
Secondary received data	(SBB)*	(SBB)*	(SBB)
Secondary request to send	(SCA)*	(SCA)*	
Data terminal ready	(CD)	(CD)	(CD)
Ring indicator	(CE)	(CE)	(CE)

*The 12966/12968A user may choose any one of the pairs SBA, SBB; SBA, SCF; SCA, SBB; or SCA, SCF. Wiring details are given in the Reference and Application Manual.

Configuration information

Computer compatibility: The 12966A and 12968A interfaces are hardware compatible with all HP 1000 M/E/F-Series Computers. The 12587B interface is compatible only with HP 1000 M-Series Computers.

System compatibility: The 12966A interface used with RTE driver DVR05 or DVA05 is compatible with all HP 1000 M/E/F-Series Computer Systems.

Computer I/O channels required: One per interface.

Software support: The 12966A interface is supported by RTE drivers DVR05 and DVA05 which are included in the RTE-II, RTE-M, RTE-IV, and RTE-IVB operating systems, for use with 2621A/P, 2635A, 2640B, 2645A, 2647A, 2648A, 2649B,

2649C, and 2649G terminals and 7221A/B/S Graphics Plotter. A user-written driver programmed in assembly language will be required for use of the 12968A or 12587B interface in an HP 1000 Computer.

Diagnostic support: Diagnostics for the 12966A, 12968A, and 12587B interfaces are provided in the 24396A-F Diagnostics Library.

Installation: To install, plug the interface into the computer I/O backplane, connect the interface cable to the modem, and integrate the interface into the operating system.

Current required from computer power supply:

	+5V	-2V	+12V	-12V
12966A	1.95	0.07A	0.02A	0.06A
12968A	1.3A	0.05A	0.01A	0.04A
12587B	1.6A	0.07A	0.08A	0.05A

Ordering information

12966A Buffered async communications interface, including:

1. 12966-60001 Asynchronous comm. interface card.
2. 12966-60003 test connector assembly cables.
3. 12966-60004 15.2m (50 ft) standard EIA terminal cable.
4. 12966-90001 Interface reference and application manual.

12966A options

- 001:** Replaces 12966-60004 standard EIA terminal cable with 12966-60008 15.2m (50 ft) cable to 264xA/B CRT terminal or 2631A or 2635A Printer or printing terminal.
- 002:** Replaces 12966-60004 standard EIA terminal cable with 12966-60006 15.2m (50 ft) cable to data set.
- 003:** Replaces 12966-60004 standard EIA terminal cable with 12966-60007 7.6m (25 ft) cable to HP 2749 Teleprinter.
- 004:** Replaces 12966-60004 standard EIA terminal cable with 12966-60011 15.2m (50 ft) cable to 7221A Graphics Plotter for hardwired connection and 12966-60012 1.5m (5 ft) cable for connection from 7221A to 264xA/B display Terminal.
- 005:** Replaces 12966-60004 standard EIA terminal cable with 12966-60010 15.2m (50 ft) cable to 2621A/P display Terminal.

12968A Asynchronous communications interface, including:

1. 12968-60001 Asynchronous comm. interface card.
2. 12966-60003 Test connector assembly cables.
3. 12966-60004 15.2m (50 ft) standard EIA terminal cable.
4. 12968-90001 Interface ref. and application manual.

12968A options

12968A options 001 through 003 are the same as 12966A options 001 through 003, above. No other options are available for the 12968A.

12587B Asynchronous communications interface, including:

1. 12587-60004 Asynchronous comm. interface card.
2. 12587-60006 15.2m (50 ft) standard data set cable.
3. 12587-90006 Interface manual.



HEWLETT
PACKARD

HP 1000 M/E/F-Series Synchronous communications interfaces

product numbers 12967A and 12618A

The 12967A and 12618A interfaces provide for connection of Bell type 201, 203, 208, or 209 data sets or equivalent modems to HP 1000 M/E/F-Series Computers, offering a choice of half duplex only or half or full duplex operation to the user.

Features

- EIA RS-232-C and CCITT V.24 compatibility
- Compatibility with Bell type 201, 203, 208, and 209 data sets or equivalent and IBM bisynchronous protocol
- Half (12967A) or full duplex (12618A) operation with secondary data channel
- Data transfer at rates to 19,200 bits/second, under program or dual channel port controller (direct memory access) control
- Double character buffering
- Special character recognition

Functional descriptions

12967A Synchronous communications interface

The 12967A provides 19,200 bits/second transmission speed in half-duplex mode only, although it can be used with full-duplex data sets to reduce line turnaround time. A secondary data channel facility offers reverse interrupt capability.

Parity generation and checking (none, odd, or even) are programmable and the data set is controlled via the interface by programmed commands. A program controlled status monitor can be used to selectively enable or disable data set status interrupts to the computer. This feature makes it possible for the 12967A to interface to data sets conforming to EIA RS-232-C and CCITT V.24 specifications.

12618A Synchronous communications interface

Unlike the 12967A, the 12618A is a two-card interface that can operate in either full or half duplex mode with Bell type 201, 203, 208, or 209 or equivalent data sets that provide timing. It communicates at rates to 9600 bits/second with fully-independent send and receive channels. Parity generation and checking (none, odd, or even), sync character, and character size are program-selectable, and the 12618A provides special character recognition/interrupt capability.

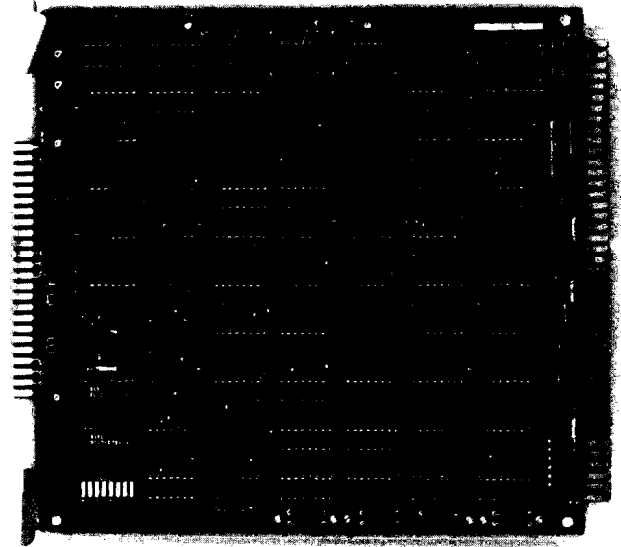

12967A Synchronous communications interface card

Functional specifications

Interface level

EIA or CCITT.

Operational mode

12967A: Half duplex only.

12618A: Half or full duplex.

Maximum data rate

12967A: Up to 19,200 bits/second.

12618A: Up to 9,600 bits/second.

Character size

12967A: Fixed at 8 bits.

12618A: Programmable, 1 to 8 bits.

Character buffering

Two characters.

Parity generation and checking

Programmable: none, odd, or even.

Special character recognition

12967A: None.

12618A: Program selectable.

Modem interface capability

The 12967A and 12618A interface with Bell type 201, 203, 208, and 209 data sets or equivalent data sets and provide secondary data channel.

Data set signals provided

EIA Designation	12618A		12967A
	Receive	Trans	
Protective ground	(AA)	(AA)	
Transmitted data		(BA)	(BA)
Received data	(BB)		(BB)
Request to send		(CA)	(CA)
Clear to send		(CB)	(CB)
Data set ready	(CC)	(CC)	(CC)
Signal ground	(AB)	(AB)	(AB)
Received line signal detector	(CF)		(CF)
Secondary received line signal detector			(SCF)*
Secondary transmitted data	(SBA)		(SBA)*
Transmitter signal element timing		(DB)	(DB)
Secondary received data		(SBB)	(SBB)*
Receiver signal element timing	(DD)		(DD)
Secondary request to send			(SCA)*
Data terminal ready	(CD)	(CD)	(CD)
Ring indicator	(CE)	(CE)	(CE)

*The user may choose either the pair SBA,SBB or SCA,SCF. Wiring details are given in the 12967A Reference and Application manual.

Configuration information

Computer compatibility: The 12967A and 12618A synchronous interfaces are hardware compatible with HP 1000 M/E/F-Series Computers.

Computer I/O channels required: One for 12967A, two for 12618A.

Software support for 12967A: A user-written driver programmed in assembly language will be required to run this interface in a real-time computer system.

Software support for 12618A: The 12618A is supported by and included in the 91780A RJE/1000 communications hardware-software package. The RJE/1000 software also includes a bisynchronous driver and an IBM 2780 Emulator for remote job entry to suitably equipped IBM 360/370 systems.

Diagnostic support: The 12967A and 12618A are supported by a diagnostic in the 26396A-F diagnostic library.

Installation: To install, plug the interface(s) into the computer I/O backplane, connect the interface cable(s) to the modem,

and integrate the interface(s) into the operating system. With the 12618A, the receive card uses the higher priority (lower select code number) I/O channel, and the send card uses the next lower priority channel. A 12620A Breadboard interface is required to serve as a privileged interrupt fence for the 12618A interface used with RJE/1000 software; it would be installed in the next lower priority I/O channel following the 12622-60001 send interface.

Electrical specifications

Current required from computer power supply

	+5V	-2V	+12V	-12V
12967A	1.75A	0.06A	0.01A	0.02A
12618A	2.8A	0.23A	0.1A	0.07A

Ordering information

12967A Synchronous communications interface

The 12967A Synchronous communications interface includes:

1. 12967-60001 Synchronous communications interface card.
2. 12967-60003 Test connector assembly.
3. 12967-60004 15.2m (50 ft) Data set cable.
4. 12967-90003 Interface reference and application manual.

12618A Synchronous communications interface

The 12618A Synchronous communications interface includes:

1. 12621-60001 Receive interface card.
2. 12622-60001 Send interface card.
3. 12621-60005 Receive test connector assembly.
4. 12622-60005 Send test connector assembly.
5. 12618-60001 15.2m (50 ft) Branched data set cable.
6. 12618-90001 Interface users manual.
7. 12621-90001 Interface manual.
8. 12622-90001 Interface manual.

91780A RJE/1000 Software (for 12618A)

For listing of items included, see the 91780A RJE/1000 data sheet, in this data book.



HP 1000 M-Series Automatic calling unit interface

product number 12589A

The 12589A Automatic calling unit interface can be used with any HP 1000 M-Series computer equipped for data communications and a Bell 801 automatic calling unit or equivalent. The interface together with the 801 allows the computer to automatically dial a predetermined phone number to access a remote terminal for data transmission. Automatic calling can be used with HP asynchronous or synchronous interface kits.

Features

- EIA RS-366 and CCITT V.24 compatibility
- Operates in conjunction with Bell 801 automatic calling unit or equivalent
- May be used with any HP synchronous or asynchronous communications interfaces

Functional description

When placed in operation, the calling unit interface card is initialized by instructions and control words from the computer. The interface then indicates to the calling device that the computer is ready to initiate a call. When the calling device is ready for operation, the computer outputs the numbers to be dialed. At the completion of dialing, the calling device switches the transmission line to the data set to allow data transmission. Remote terminals calling into the system are routed directly to the data set for automatic answer and subsequent data transmission.

Functional specifications

Device status lines

Power indicator (PWI)
Present next digit (PND)
Data line occupied (DLO)
Call origination status (COS)
Abandon call and retry (ACR)

Device control and dialing lines

Call request (CRQ)
Digit present (DPR)
Four digit leads (NB1, NB2, NB4, NB8)

Compatible communications equipment

The 12589A is compatible with Bell 801A or 801C automatic calling unit or equivalent.

Interface level

EIA RS-366, CCITT V.24

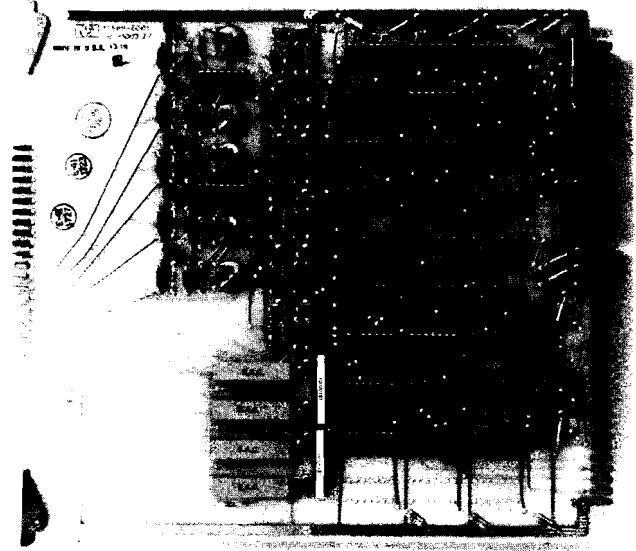

Configuration information

Computer compatibility: The 12589A is hardware-compatible with 2105, 2108, and 2112 Computers.

Computer I/O channels required: One.

Software support: Contact your HP Sales Representative for more information.

Installation: To install, plug the 12589A interface into the computer backplane, connect the interface cable to the automatic calling unit, and integrate the interface into the operating system.

Current required from computer power supply:

0.65A(+5V), 0.05A(-2V), 0.05A(+12V), 0.055A(-12V)

Ordering information

12589A Automatic calling unit interface

The 12589A Automatic calling unit interface includes:

1. 12589-6001 Automatic calling unit interface card.
2. 12589-6004 Interface cable.
3. 12589-6005 Test connector.
4. 12589-90002 Interface manual.



Hewlett-Packard Modems Selection Guide

product numbers 37210T, 37220T, and 37230A

Three different Hewlett-Packard synchronous modems are available for use in DS/1000-IV, RJE/1000, and multipoint communications circuits. All of these modems incorporate automatic equalization and selectable transmit levels. Capabilities and performance of these modems are summarized in Table 1. Physical and environmental specifications and power requirements are given in Table 2. For more detailed information on any of the modems, ask your Hewlett-Packard representative for the data sheet on that modem.

37230A Short Haul Modem (top) and 37210T 4800 bps Synchronous Modem (bottom); 37220T 9600 bps Synchronous Modem is similar to 37210T Modem.

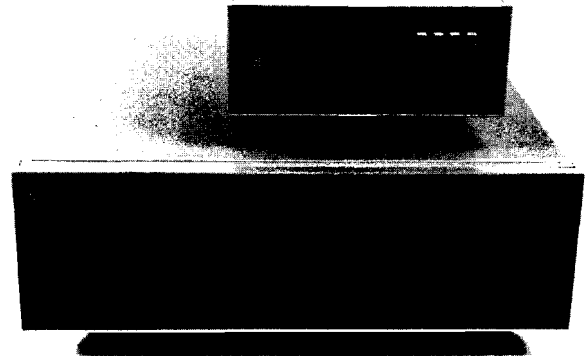

Table 1. HP Modems capability and performance comparison

Product Number & Name	Data Rate (bits/sec)	Communications			Circuit Requirement	Transmit Levels	Auto Equal. Init. Time
		Range	Use	Mode			
37210T Sync Modem	4800, fallback to 2400	No limit	Point-point & Multipoint	Full-duplex	Four-wire leased	0dBm to -15dBm, selectable in 1dB steps	50ms normal, 708ms long
			Point-point	Half-duplex	Two-wire dial-up		
37220T Sync Modem	9600, fallback to 4800	No limit	Point-point	Full-duplex	Four-wire leased D1 conditioned line	0dBm to -16dBm, selectable in 2dB steps	2.8 sec
37230A Short Haul Modem	2400	35.4km/22mi*	Point-point & Multipoint	Full-duplex	Four-wire customer installed or leased line	0dBm, -9dBm, -14dBm, & -21dBm at 600 ohms; +6.3dBm, -2.7dBm, -7.7dBm, & -14.7dBm at 140 ohms	25ms (2400bps)
	4800	29.0km/18mi*					15ms (4800bps)
	9600	20.9km/13mi*	Half-duplex	Two-wire customer installed or leased line	10ms (9600bps)		
	19200	14.5km/9mi*			8ms (19200bps)		

* These distances are based on maximum output levels and use of 19AWG conductor cabling. The higher resistance per unit length of smaller cabling reduces maximum distance, to approximately 44% of that listed if 26AWG conductor cabling is used. At 4800 bps and higher rates, lower transmit levels required to comply with Bell system line requirements as listed in Bell publication 43401 also reduce maximum distances, to about 85% of that listed for 4800 bps, about 70% of those listed for 9600 and 19200 bps.

Table 2. Physical and environmental specifications and power requirements for HP Modems

Product Number & Name	Dimensions (Height x Width x Depth)	Net Weight	Operating Temperature	Relative Humidity	Power Line		Power Consumption
					Voltage	Frequency	
37210T & 37220T Sync Modem	133 x 425 x 425mm/ 5.25 x 16.75 x 16.75in	9.2kg/ 20.3lb	0° to 45°C/ 32° to 113°F	5% - 95%, non-condensing	100V/120V/ 220V/240V +/-10%	48-66Hz	85VA, max.
37230A Short Haul Modem	102 x 213 x 285mm/ 4 x 8.4 x 11.2in	2.5kg/ 5.5lb	0° to 55°C/ 32° to 131°F	5% - 95%, non-condensing	100V/120V/ 220V/240V +/-10%	48-66Hz	10VA



DS/1000 Network software-firmware for HP 1000 M/E/F-Series Computers

(mature software)

product numbers 91740A/B and 91741A

Distributed Systems/1000 (DS/1000) software and firmware provides an integrated set of high-level network facilities and procedures for HP 1000 M/E/F-Series Computer Systems. These facilities and procedures support network resource-sharing, remote data base access, distributed data file management, communication between application programs, and the coordinated distribution of processor workloads to other HP 1000 M/E/F-Series Computer Systems and/or to HP 3000 Series II/III systems.

The 91740A/B DS/1000 software and firmware supports direct or modem connections between HP 1000 M/E/F-Series Computer Systems operating under HP's disc-based RTE-IV/IVB (or RTE-III) or memory-based RTE-M real-time executive operating system. Such HP 1000 Computers or Systems constitute a DS/1000 network, with each system one node in the network. The 91740A provides firmware and software for HP 1000 M-Series (2108 and 2112) computers; the 91740B provides firmware and software for HP 1000 E/F-Series Systems or HP 1000 E-Series (2109 and 2113) and F-Series (2111 and 2117) computers.

Addition of the 91741A DS/1000 software enhancement to the 91740A/B supports hardwired network connections between RTE-IV/IVB (or RTE-III) or RTE-M based HP 1000 Computer Systems and 32190A DS/3000 software in an HP 3000 Series II/III system.

Features

- Generalized DS/1000 network architecture
- Compatibility with DS/3000
- DS/1000 network-wide nodal addressing with store-and-forward for maximum configuration flexibility
- Firmware driver optimized for concurrent servicing of multiple hardwired or modem lines with error correction
- Remote system generation and remote program development and testing (between HP 1000 systems only)
- Remote command processing between any DS/1000 network nodes
- HP 1000 virtual terminal capability with respect to HP 3000 Series II/III system

DS/1000 capabilities

DS/1000 capabilities with respect to both HP 1000-to-HP 1000 and HP 1000-to-HP 3000 communication are summarized in Table 1, on the next page, and discussed in the following paragraphs.

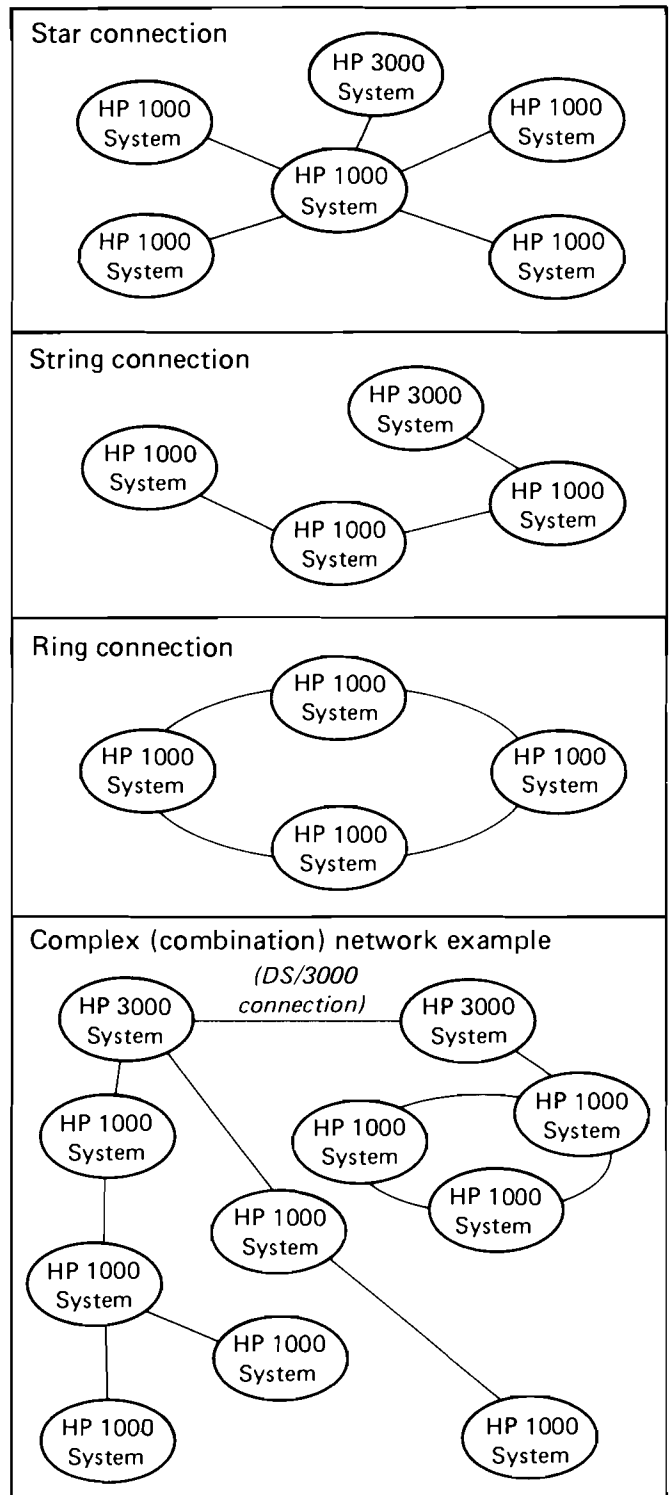

DS/1000 Network configuration choices

Table 1. 91740A/B and 91741A Network communications capabilities

HP 1000 to HP 1000	HP 1000 to HP 3000	HP 3000 to HP 1000	Capability
REMOTE COMMAND PROCESSING COMMANDS			(Local operator's requests to local or remote DS/1000 nodes)
RTE	MPE	RTE	The local operator can issue any RTE system command to the remote HP 1000 system, except for running the file manager. The local HP 1000 operator can issue MPE II/III commands to the remote HP 3000 system, including access to HP 3000 subsystems, such as Cobol and QUERY/3000.
REMAT		NOTE: The following additional capabilities are provided by the DS/1000 remote command processor, REMAT: node 1 and/or node 2 can be either local or remote.	
BC		Sends a message to all other nodes	
CL		Lists mounted cartridges at node 1 on LU at node 2	
CR		Creates a file at node 1.	
DL		Lists the file directory at node 1 on LU at node 2.	
DU		Dumps a file or LU input from node 1 to LU at node 2	
EX		Terminates: REMAT	
FL		Closes a file at node 1.	
LC		Displays the local node number.	
LI		Lists a file at node 1 on LU at node 2.	
LL		Changes the local list or log device.	
LO		Loads an absolute program from a node 1 file or LU into an RTE-M system at node 2.	
PL		Lists all programs resident in an RTE-M system at node 1.	
PU		Purges a file at node 1.	
RN		Renames a file at node 1.	
SL		Lists all program-to-program "slave" programs at node 1.	
SO		Terminates a slave program at node 1.	
ST		Stores all records from a file or LU at node 1, to a file at node 2	
SW		Transfers execution of subsequent commands to/from specified nodes.	
TE	Sends a message to the operator at node 1.		
TR	Transfers control of REMAT to a file or LU at a DS/100 node.		
REMOTE QUERY ACCESS TO IMAGE/1000 DATA BASE			(Local operator's requests to QUERY at remote HP 1000 System)
DATA BASE			Tells remote QUERY which data base to access.
SELECT FILE			Tells QUERY which file to use during data base access operations.
CREATE			Creates procedure file at the remote node for repetitive data base access operations.
DISPLAY			Displays previously-created QUERY procedure file.
EXECUTE			Runs interactive editor at remote node for editing procedure files, or runs any other specified program.
DESTROY			Deletes previously-created QUERY procedure at remote node.
FIND			Locates one or a group of data item names and/or data item values.
UPDATE			Adds, changes, or deletes a data item(s) that have been located in the remote data base by the FIND command
REPORT			Displays or prints out data item(s) that have been located by the FIND command.
FORM			Lists remote data base structure.
HELP			Explains form and purpose of specified types of QUERY commands or all QUERY commands
EXIT			Terminates remote QUERY execution.
XEQ			Transfers command input to a file.
LIST			Changes list device

HP 1000 to HP 1000	HP 1000 to HP 3000	HP 3000 to HP 1000	Capability
PROGRAM-TO-PROGRAM (PTOP) INTRINSICS			(Program requests for communication between programs at local and remote HP 1000 and/or HP 3000 systems)
POPEN	POPEN	POPEN	From master program, initiates PTOP communications and schedules a slave program in the remote node, if necessary.
PREAD	PREAD	PREAD	Reads data block from remote program and exchanges tags
PWRIT	PWRIT	PWRITE	Sends data block to remote program and exchanges tags
PCONT	PCONT	PCONTROL	Exchanges userdefined tag field with remote slave program for user-defined control functions.
PCLOS	PCLOS	PCLOSE	Disconnects remote slave program from the master and initiates its termination.
GET	GET	GET	Gets next request from the remote master program.
ACCEPT	ACCEPT	ACCEPT	Accepts and completes the master program's request.
REJCT	REJCT	REJECT	Rejects the master program's request
FINIS	FINIS	FINIS	From slave program, terminates communication with all master programs. Communication can be re-established by the master program by issuing a POPEN.
REMOTE DATA BASE ACCESS (RDBA) INTRINSICS			(Program requests for access to a data base in a remote HP 1000 system)
DBOPN			Initiates access to data base.
DBINF			Provides information on the organization and components of the data base.
DBFND			Locates master data set entry containing a specified key item value.
DBGET			Reads data items.
DBUPD			Modifies values of data in existing records.
DBPUT			Adds new records.
DBDEL			Deletes existing data records.
DBLCK			Locks a data base temporarily to provide exclusive access.
DBUNL			Unlocks data base after DBLCK call.
DBCLS			Closes the data base files.
REMOTE FILE ACCESS (RFA) INTRINSICS			(Program requests for access to files in a remote HP 1000 or HP 3000 system)
DCRET		DCRET	Creates a file.
DNAME	FRNAM	DNAME	Renames a specified file.
DPURG		DPURG	Removes a file and directory entry.
DOPEN	FOPEN	DOPEN	Opens a specified file.
DCLOS	FCLOS	DCLOS	Closes a specified file.
DREAD	FREAD	DREAD	Transfers one record from a file (sequential file on HP 3000).
	FRDIR		Reads a record from a direct access file.
	FRLAB		Reads a user's file label.
DWRIT	FWRIT	DWRIT	Transfers one record to a file (sequential file on HP 3000).
	FWDIR		Writes a record to a direct access file.
	FWLAB		Writes a user's file label.
	FSTMD		Changes file access mode.
	FLOCK		Dynamically locks a file.
	FUNLK		Dynamically unlocks a file.
	FUPDT		Updates a record in a file.
DPOSN	FSPAC	DPOSN	Positions a file.
DAPOS		DAPOS	Positions a file to a specified record.
	FPOIN		Resets pointer for sequential file.
	FRDSK		Prepares for reading a direct access file.
DCONT		DCQNT	Sends control request to peripheral device identified as type 0 file.
	FCNTL		Control of file or terminal device.
DWIND		DWIND	Resets file to first record.
DLOCF	FINFO	DLOCF	Returns file status.
	FCHEK		Requests details on file I/O status.
DSTAT		DSTAT	Returns status of mounted discs
	FRLAT		Determines if file pair is interactive or duplicative.

Table 1. 91740A/B and 91741A Network communications capabilities, continued

HP 1000 to HP 1000	HP 1000 to HP 3000	HP 3000 to HP 1000	Capability
REMOTE RTE EXEC CALLS			(Program requests for action by RTE exec in remote system)
DEXEC (1)		DEXEC (1)	Read from an I/O device at remote system.
DEXEC (2)		DEXEC (2)	Write to an I/O device at remote system.
DEXEC (3)			Control an I/O device at remote system.
DEXEC (6)			Terminate a remote program.
DEXEC (9)			Schedule a remote program with wait.
DEXEC (10)		DEXEC (10)	Schedule a remote program without wait.
DEXEC (11)		DEXEC (11)	Request time from the system clock in remote system.
DEXEC (12)		DEXEC (12)	Set execution interval or start time of a remote program.
DEXEC (13)		DEXEC (13)	Request status of a remote system I/O device.
DEXEC (23)			Queue schedule a remote program with wait.
DEXEC (24)			Queue schedule a remote program without wait.
DEXEC (25)			Request partition status from remote system.
DEXEC (99)			Request remote program status.

HP 1000 to HP 1000	HP 1000 to HP 3000	HP 3000 to HP 1000	Capability
DS/1000 UTILITY CALLS			(DS/1000 Network utility program requests)
DMESG			Sends message to remote operator's display device or remote system's message processor.
GNODE			Obtains node number of the local system.
FLOAD			Down-loads absolute program into a remote RTE-M node.
FCOPY			Copies a file from one node to another.
EDITR			Provides interactive access to the RTE editor at a remote disc-based RTE node.
DNODE			Establishes destination node for formatted FORTRAN I/O statements.
DMESS			Sends command from program to remote command processor.

Nodal addressing (HP 1000-HP 1000 only)

Within a network of interconnected HP 1000 Computers or Systems, each system is assigned a unique node identification number by the user. Remote operator commands and user program requests reference the number(s) of the node(s) to which they are directed.

Node numbers for DS/1000 network connections are specified after an RTE operating system has been generated and loaded. A Nodal Routing Vector (NRV), which specifies the logical unit number (LU) through which any DS/1000 transaction goes to get from the local node to the target node, can be generated interactively or read from a Network Description Table (NDT) file at each DS/1000 node. A NDT specifies every connection in the DS/1000 network and consists of a list of the NRV's which reside in each node. An example is shown in Figure 1.

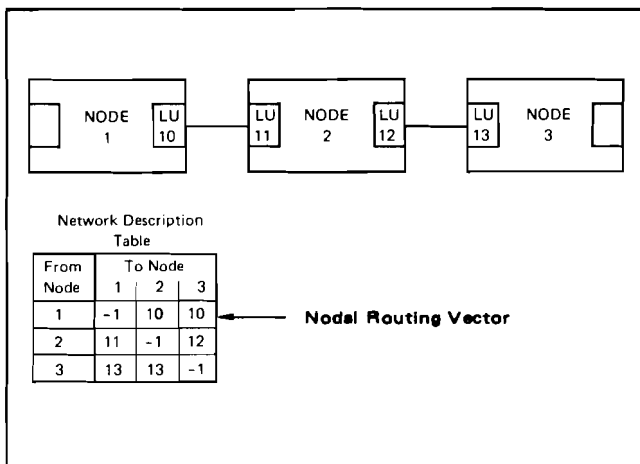

Figure 1. Nodal addressing via Network Description Table

Store and forward operations (HP 1000-to-HP 1000 only)

Using the example of Figure 1, a transaction goes from node 1 to node 2 or node 3 via LU10. At node 2, the DS/1000

communications management processors examine the destination node address on the transaction and either link the transaction to the local network interface monitors for processing if addressed to node 2, or forward the transaction to node 3 via LU12. The NRV describes a single communications path between any two HP 1000 nodes regardless of whether there is a direct, neighbor connection between them. Store-and-forward communications are not limited to a specified number of levels. However, store and forward to or through an HP 3000 system is not supported.

Nodal addressing with store-and-forward offers important advantages. Hardwired or modem-based lines can be shared in a string or ring configuration, reducing initial costs for hardwired connections or operating costs for data communications. A program can be written, debugged, and tested in one node and then transported to any other HP 1000 node in the network while accessing the same local or remote peripheral logical units, or slave application programs. Finally, no user application programs are required to perform store-and-forward functions in any node.

Remote command processing

HP 1000-to-HP 1000. DS/1000 remote command processing makes it possible for a user at a local terminal to interactively access any HP 1000 system in the DS/1000 network, via the nodal addressing and store-and-forward capabilities of DS/1000. The local operator can use the entire RTE command set* of the remote node as well as special network-oriented commands provided by the DS/1000 remote command processor, REMAT. As shown in Table 1, the REMAT capabilities include local or remote file creation, listing and/or purging, file transfer and remote program scheduling. A Network Security Code (NSC) is required to direct commands to a remote system, which protects the network from unauthorized use of remote command processing. Remote command processing is initiated as easily as:

**ON, REMAT
\$SW, N1, N2, NSC**

This two-command sequence turns on REMAT and directs subsequent RTE and/or REMAT commands to Node 1 (N1) or from Node 1 (N1) to Node 2 (N2). The accompanying Network Security Code (NSC) is always required. By providing for Node 1 to Node 2 actions, DS/1000 remote command processing supports the direction of activities at unattended DS/1000 nodes.

HP 1000 virtual terminal to HP 3000. The operator at an HP 1000 system communicating with HP 3000 can execute local HP 3000 MPE commands. The HP 1000 system thereby becomes a virtual HP 3000 terminal, gaining access to facilities not available on the HP 1000, such as the COBOL compiler and QUERY/3000. Security is controlled by the requirement for an account (and, optionally, a password) in the HELLO sign-on command addressed to the HP 3000. Access to the HP 3000 from the HP 1000 is obtained by these three simple commands:

```
RU, RMOTE
$SW
#HELLO (account)
```

HP 3000-to-HP 1000. An operator at the HP 3000 can execute any RTE operator command*, thereby supporting control of an unattended HP 1000 satellite system.

**Only RTE operating system commands are supported. RTE sub-systems such as the file manager and RJE/1000 are excluded from remote command processing capabilities available at local HP 1000 or HP 3000 systems since they require a local list device.*

Remote data base access between HP 1000 Systems

Remote Query access now makes it possible for an operator at a memory-based or disc-based system to interactively access data in a 92069A IMAGE/1000 data base in a remote HP 1000 Computer System operating under RTE-IVB. Remote access is essentially as easy as local access, since all command mnemonics and parameters are the same. The one exception is that the RU, QUERY request is issued from REMAT in the local system to the remote system and must include the node number of the local system.

Remote access from programs is accomplished with similar ease. All data base access calls, both local and remote, include an IBASE array parameter. The only difference between a local data base call and a remote one is that one of the words in the IBASE array in the DBOPN call for remote access contains the node number of the system whose data base is to be accessed. This provides total program transportability among systems in the DS/1000 network and greatly facilitates the establishment of network-wide distributed data bases.

Program-to-program data exchange (PTOP)

Using high-level distributed system calls (Table 1), a FORTRAN or Assembly language program in an HP 1000 node can initiate a data exchange with a named FORTRAN or Assembly language program in a remote HP 1000 system or a FORTRAN or SPL program in a remote HP 3000 Series II/III system. A program in the HP 3000 can also initiate the PTOPI exchange.

Multiple PTOPI data exchanges can be active on the same network connection concurrently and in HP 1000 systems one program can communicate with more than one remote node concurrently. PTOPI between HP 1000 systems and from HP 1000 to HP 3000 system supports data buffers up to 8k bytes long; PTOPI from an HP 3000 to HP 1000 system supports 1k byte buffers.

In addition to its use for exchanging data to be processed, the PTOPI capability can be used by the customer to implement access by remote programs to IMAGE/1000 or IMAGE/3000 data bases residing on their local system. The records can be transferred to/from the remote requesting program, using PTOPI intrinsics.

Remote file access

High-level DS/1000 calls analogous to standard RTE-FMP or FS/3000 calls can be used by FORTRAN/Assembly language programs in HP 1000 systems and FORTRAN/SPL

programs in HP 3000 systems to define, access, control, and query the status of named files in remote HP 1000 or HP 3000 Series II/III systems. This capability facilitates the establishment, maintenance, and use of distributed data files, by the intrinsics listed in Table 1.

Remote calls to the RTE system executive

FORTTRAN/Assembly language programs in an HP 1000 system or FORTRAN/SPL programs in an HP 3000 Series II/III system can make calls to the system executive or remote HP 1000 systems to write to, read from, control, or get status of I/O devices. Other calls can be used to request partition and/or program status, schedule programs with or without wait, request system clock time, and to set execution interval or start time of a program. A single HP 1000 node can concurrently service multiple system executive request calls, which are listed in Table 1.

Remote FORTRAN read/write (HP 1000-to-HP 1000 only)

The FORTRAN IV formatter for RTE systems, working with DS/1000 subroutine RMTIO, supports locally programmed FORTRAN read/write statements to read from or write to any logical unit (LU) specified peripheral device at any specified remote node with programming as simple as:

```
C WRITE A MESSAGE ON LU NO. 6 AT NODE NO. 21
  CALL DNODE(21)
  WRITE(6,10)
  10 FORMAT("DS/1000 SUPPORTS REMOTE FORTRAN I/O")
```



Remote HP 1000 node system generation

Operating systems for RTE-IV/IVB (or RTE-III) or RTE-M based DS/1000 nodes can be generated at a single RTE-IV/IVB (or RTE-III) based DS/1000 node and copies distributed using FCOPY and loaded locally. RTE-M systems can also be generated remotely and loaded directly into neighboring RTE-M based nodes from RTE-IV/IVB based DS/1000 nodes, using the communications bootstrap loader (CBL) ROM.

Utilizing the Remote Program Load (RPL) feature of the HP 1000 F- and E-Series Computers, the Communications Bootstrap Loader (CBL) can be automatically invoked at the time of initial power turn-on, to perform a complete remote load (or re-load) of an entire RTE-M operating system. The complete RTE-M operating system, network communications subsystem, and user applications programs can be loaded, initialized, and started through the simple act of applying (or restoring) power to the system.

Remote HP 1000 node program development

Program development for an entire DS/1000 network of HP 1000 nodes can be accomplished at a single DS/1000 node. At an RTE-M node, programs for other DS/1000 nodes can be developed on-line, relocated off-line, and loaded on-line into RTE-M nodes by operator command or program call. If necessary, these programs can be relocated into RTE-IV/IVB (or RTE-III) nodes by operator command. At an RTE-IVB node, programs can be developed and relocated on-line and loaded into any target RTE-M node using an operator command or a program call. Programs can also be relocated into any target RTE-IV/IVB (or RTE-III) node by operator command.

Network utilities (HP 1000-to-HP 1000 only)

Network utilities provide single-call programming for such network tasks as sending messages to remote HP 1000 nodes, retrieving local node numbers, and copying files from

any HP 1000 node to any other HP 1000 node. The interactive RTE Editor can be run at remote RTE-IV/IVB (or RTE-III) nodes. These capabilities make the network manager's and application programmer's jobs easier.

Operational restrictions with respect to RTE-IVB

The slave monitors that support the various remote access capabilities of DS/1000 run outside of the Session Monitor in RTE-IVB. This imposes the following operational limitations:

1. Remote file access is restricted to files on system discs; private and group files are not accessible.
2. Programs scheduled by other programs in the DS/1000 environment must reference actual system logical unit numbers as they do now, not session logical unit numbers as is possible with local-only session operations in RTE-IVB.
3. RTE-IVB time slice priority must be set lower than the lowest priority DS/1000 program.
4. All logical unit numbers used in DEXEC calls must be in the range 1 to 63, inclusive.
5. DS/1000 must be initialized (or shut down) from the system console, not a session terminal.

HP 1000-to-HP 1000 network description

Layered architecture

The DS/1000 software-firmware and hardware for HP 1000-to-HP 1000 connections in each system, or network node, consists of several layers, as shown in Figure 2. The Network

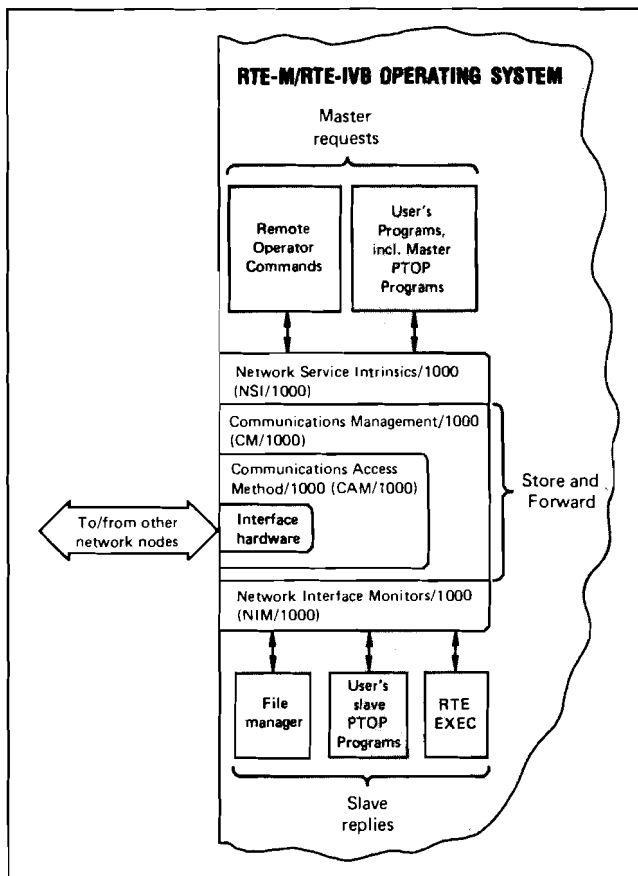

Figure 2. DS/1000 Layered Network Communications Architecture

Service Intrinsic (NSI/1000) are called by user's application programs or operator commands to generate the transaction format for master requests to remote nodes, with data as required. The master requests generated are those for PTOP, RFA, DEXEC, Remote operator command, and utility program capabilities described in Table 1.

The Network Interface Monitors (NIM/1000) process incoming master requests received from Communications Management software (CM/1000) and link them as required to user's slave PTOP programs, file management routines, or the RTE exec. The CM/1000 layer routes network transactions, queues them, and manages the local system resources necessary for network communications. CM/1000 also manages the store-and-forward operations.

The CM/1000 layer communicates with the interface hardware, which may be several hardwired and/or modem interface cards, via the Communications Access Method/1000 (CAM/1000) software and firmware. CAM/1000 provides a line protocol for the control of communications input and output, including error detection and correction by retransmission. The lower layers are managed by software, firmware, and hardware such as to be completely transparent to the user. Changes to these layers of the network can be made with little or no effect on user's application programs.

Modular software supports three upward-compatible levels of DS/1000 node capability

Another advantage of Hewlett-Packard's layered approach to network communications software and firmware is its modularity — modularity that accommodates three main levels of network capability, with many gradations in between.

Minimum RTE-M nodes are low-cost, non-mapped memory based systems intended for execute-only use in measurement and control, automatic test, or data capture applications. This RTE-MII configuration supports HP 1000-to-HP 1000 communication or HP 1000-to-HP 3000 communication, but not both, since this requires more than 64k bytes of memory. For the same reason flexible disc file management cannot be supported in the same node as the 91741A HP 1000-to-HP 3000 software. The minimum RTE-M node uses a subset of the DS/1000 software-firmware, a subset that is in keeping with its dedicated role. Yet, whenever more capability is desired in a memory-based node, it can be easily upgraded to a larger mapped RTE-M configuration by adding dynamic mapping and more memory and regenerating the system.

Mapped RTE-M nodes are memory based systems whose larger memory capacity (128k to 2.048 million bytes) give them far more capability than minimum RTE-M nodes. Their RTE-MIII configuration can support both HP 1000-to-HP 1000 and HP 1000-to-HP 3000 communication. They can also provide local flexible disc based program development and off-line system generation capabilities and local program and data files accessed from multiple terminals. These added capabilities are in addition to the ability to perform multiple tasks similar to those of the minimum node. RTE-M program calls are compatible with RTE-IVB, which facilitates upgrading.

RTE-IVB nodes are the most capable of all. They require 128k bytes of memory, expandable to 2.048 million bytes, and at least 4.9 million bytes of disc memory (up to 960 million bytes can be provided). Because of their large main and disc memory capacities, RTE-IVB nodes can provide network-wide support for HP 1000 system generation and program development, high speed computation, and data

file facilities to other nodes operating under RTE-M or RTE-IV/IVB (or RTE-III). The RTE-IVB node can support HP 1000-to-HP 3000 communication as well as communication to other DS/1000 nodes.

Transaction request buffering

The Network Interface Monitors in DS/1000 (for program-to-program data exchange, remote file access, and remote I/O and program scheduling) interface to CM/1000 communications management processors via complete requests and replies with data buffers as required. Therefore, the Network Interface Monitors can service multiple requests or replies concurrently and the monitors themselves can be swapped in RTE-IVB while the system performs the data transfer, thereby freeing up memory for other programs or tasks.

CAM/1000 microcoded driver

CAM/1000 is a combination of software and firmware that is specifically designed to keep throughput high while servicing concurrent transactions on multiple hardwired and/or modem-based DS/1000 communication lines. The use of fast-executing firmware for the most time-critical portions of the driver provides fast switching between lines and high transfer rates. Where necessary to minimize interrupt latency time with hardwired communications on heavily-loaded DS/1000 nodes, a privileged interrupt mode can be used. (Privileged interrupt is always used for DS/1000 modem communications).

DS/1000 architecture for HP 1000-to-HP 3000 communication

DS/1000 software as enhanced for HP 1000-to-HP 3000 communications is layered similarly to Figure 2. The important differences appear in the bottom two layers. The CM/1000 layer includes translators for conversion of HP 1000 requests and replies to/from DS/3000 format. CM/1000 software is designed to work with only one remote HP 3000 system and does not provide for nodal addressing or store and forward operation to/from the HP 3000. CAM/1000 for HP 1000-to-HP 3000 communication is a software-only synchronous line controller.

Communications facilities

HP 1000-to-HP 1000 connections

As shown in Figure 3, HP 1000 Computer Systems can communicate via either direct connect or modem links. The 12771A direct connect interface operates at rates to 62.5k bytes/sec† at distances to 180 metres (600 ft) and at lower rates over longer distances up to 3 kilometres (10,000 ft). The 12771A can operate with or without the 12620A interface for privileged interrupt control. In lightly-loaded HP 1000 systems, non-privileged operation gives higher throughput.

The 12773A modem interface operates with full duplex modems asynchronously at rates to 1200 bits/sec or synchronously at rates to 19,200 bits/sec†. The 12773A must be used with the 12620A interface for privileged interrupt control and is compatible with Bell type 103, 201, 202, 208, and 209 Data sets and with Vadic VA3400 modems (synchronous operation only) or equivalent modems.

†These are maximum hardware data rates; actual throughput rates will be lower because of the overhead of DS/1000 and RTE operating system software.

HP 1000-to-HP 3000 connection

As shown in Figure 3C, an HP 1000 Computer System connects to an HP 3000 Series II/III system via a 12889A Hardwired serial interface and a counterpart hardwired interface in the HP 3000 system. The 12889A operates at rates to 250k bytes/sec† at distances to 300 metres (1,000 ft) or at 125k bytes/sec† over distances to 600 metres (2,000 ft).

Efficient error control

HP 1000-to-HP 1000 communication

The accuracy of both hardwire and modem communications between HP 1000 systems is supported by LRC/VRC/DRC (longitudinal, vertical, and diagonal) redundancy checking. Vertical parity is checked by the interface card at the receiving node. Longitudinal and diagonal parity words are generated by the microcoded CAM/1000 drivers in the transmitting and receiving nodes. The receiving node returns its parity words to the transmitter for comparison. A parity word mismatch causes retransmission of the block. Because error control is accomplished mostly in firmware system overhead is kept low.

HP 1000-to-HP 3000 communication

HP 1000-to-HP 3000 communications are error-checked by the CRC-16 error detection method, which is implemented in hardware on the 12889A interface card. Detection of an error results in a request for retransmission.

Functional specifications

Network capacity

The effective data transfer rate between any pair of DS/1000 network nodes is a complex function of the following factors:

- Type and speed of the communications link
- The way in which a user application program uses a particular type of DS/1000 network service intrinsic (such as PTOP or RFA)
- The processing time required by the DS/1000 software-firmware and the user's application in a particular HP 1000 Computer
- The resources, such as system available memory, available in the computer at each node
- Other activity at the node itself

Despite this complexity, it is possible to predict the maximum possible throughput between any pair of network nodes given an environment optimized for that maximum throughput. This type of upper limit figure is specified below. Hewlett-Packard strongly recommends that you consult with an HP System Engineer to estimate throughput in your particular application.

HP 1000-to-HP 1000 Communications: The maximum possible sustained throughput between two DS/1000 nodes is achieved by utilizing Program-to-Program (PTOP) Communication between HP 1000 E-Series Computers configured and linked via a hardwired line less than 180 metres (600 ft) long, with the configuration shown in Figure 4. The computers are completely dedicated to DS/1000 communications, with no other activity at either node. The maximum sustained throughput is an increasing function of buffer size, as plotted in Figure 5.

A HP 1000-to-HP 1000 Hardwired connection

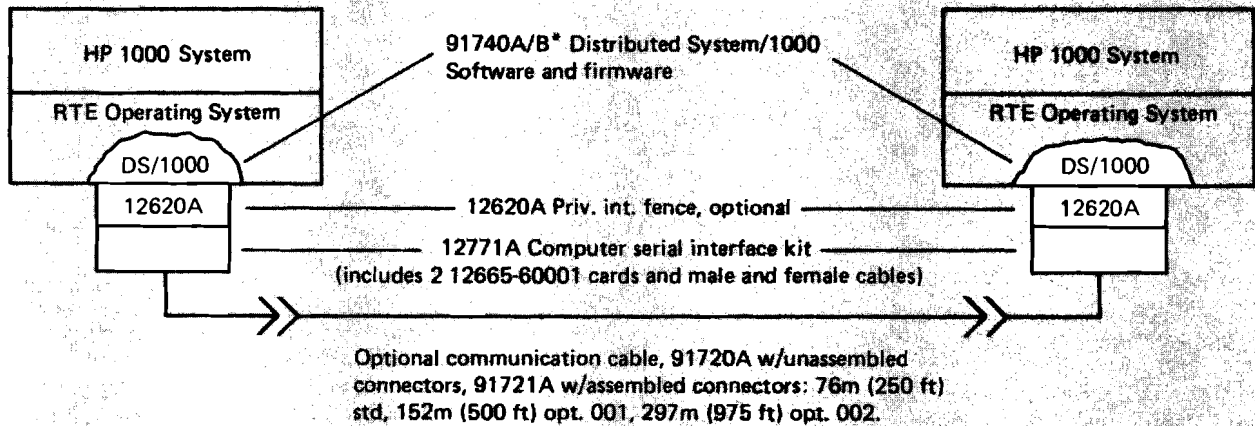

B HP 1000-to-HP 1000 Modem connection

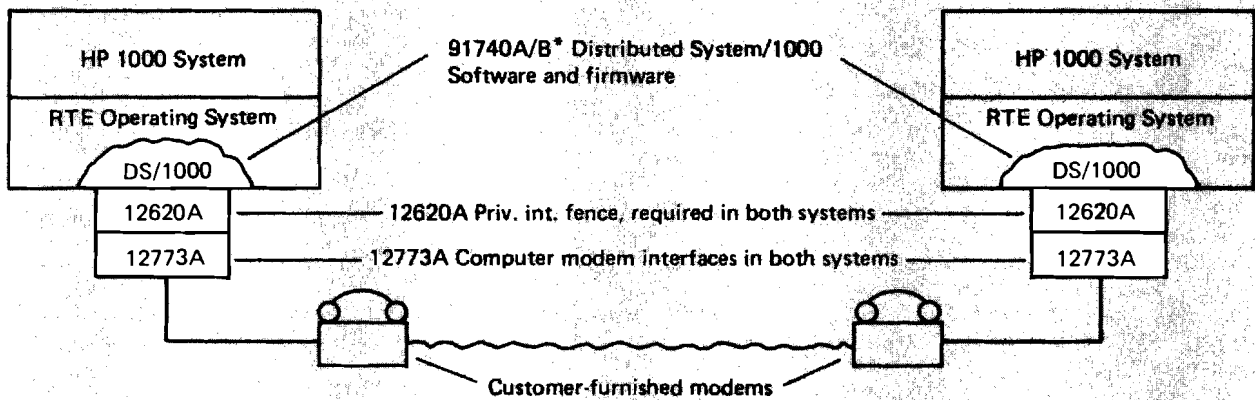

C HP 1000-to-HP 3000 Series II/III Hardwired connection

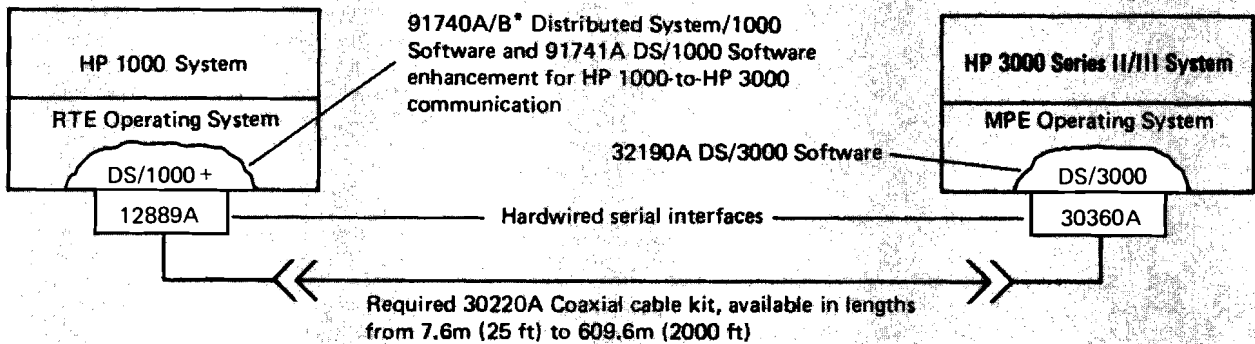

*91740A DS/1000 Software-firmware is for HP 1000 M-Series (2108 and 2112) Computers.
91740B DS/1000 Software-firmware is for HP 1000 Systems and HP 1000 E-Series (2109 and 2113) and F-Series (2111 and 2117) Computers.

Figure 3. DS/1000 network connections

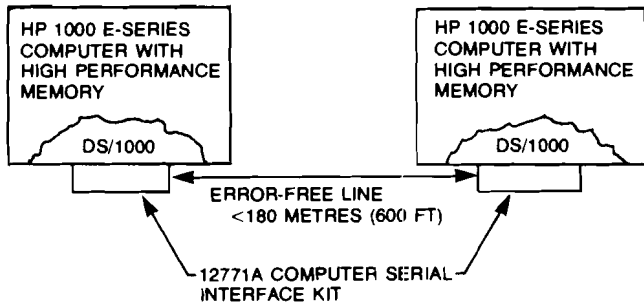

Figure 4. DS/1000 Configuration for maximum throughput

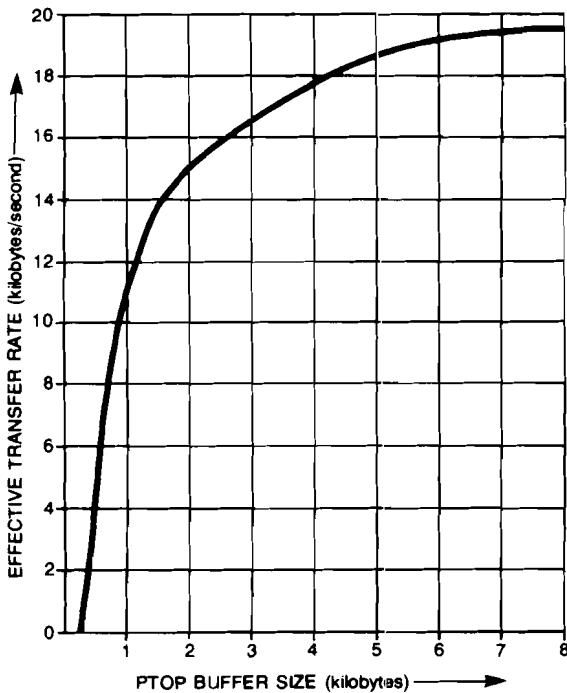

Figure 5. Maximum transfer rate vs PTOP buffer size

The DS/1000 overhead at a given node, defined as a percent of the cpu's time otherwise available to a computer-bound user program varies between 40% and 45% for the single hardwired link plotted above. DS/1000 overhead is a function of the maximum bit rate on a line. For example, the overhead for PTOP communication on a 9600 baud line varies between about 5% for small buffers to less than 2% for large buffers.

The maximum PTOP throughput into the central node of a star network configuration is reached when 100% of the central node's cpu is used servicing concurrently active PTOP data exchanges. For hardwired links of less than 600 feet, this occurs for five(5) concurrently active PTOP data exchanges to five different satellite nodes. (More nodes can be connected, but only five can be active concurrently in the described situation.)

Using 8,000 byte data buffers, the total throughput into the central node of Figure 6 (next page) can be approximately 54,000 bytes per second.

It is important to understand that the case discussed above is one extreme, limiting case. Total throughput rates less than 54,000 bytes/sec will require less than 100% of cpu

time and could permit the concurrent operation of more than the five nodes shown in Figure 6 and/or the execution of other concurrent operations in the computer.

HP 1000-to-HP 3000 Communications: The maximum transfer rate between an HP 1000 E-Series Computer system equipped with high performance memory and an HP 3000 Series II/III Computer System is also achieved using Program-to-Program (PTOP) communications. Given that both systems are dedicated only to DS/1000-to-DS/3000 communications, the maximum sustained transfer rate is approximately 4,000 bytes per second at an HP 1000 overhead rate varying between 34% and 38%. The systems can be up to 1,000 feet apart at this level of throughput.

Transmission choices and maximum distances

HP 1000-to-HP 1000 hardwire transmission: Up to 3.048 km (10,000 ft); uses 12771A Computer serial interface kit, which includes two interfaces and one male and one female cable.

HP 1000-to-HP 1000 modem transmission: Distances are limited only by the common-carrier networks; uses 12773A Computer modem interface card.

HP 1000-to-HP 3000 hardwire transmission: Up to 608m (2,000 ft); uses 12889A Hardwired serial interface card.

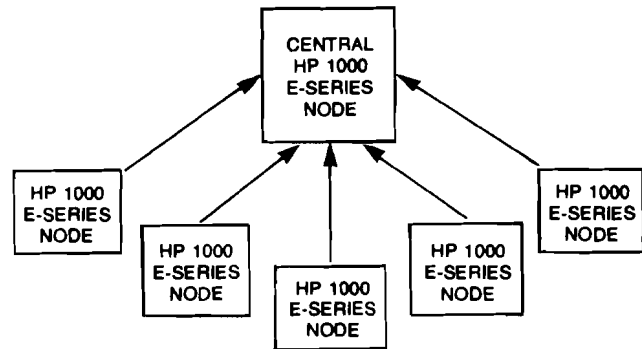

Figure 6. Maximum star configuration supportable at maximum 54k bytes/sec rate for under-180 metre (600 ft) hardwired connection

Configuration information

Computer and operating system compatibility

Product	Compatible computers	Compatible op systems
91740A	2108 & 2112	RTE-M/IV/IVB/III
91740B	2109, 2111, 2113 & 2117	RTE-M/IV/IVB/III*
91741A	2108, 2109, 2111, 2112, 2113, & 2117	RTE-M/IV/IVB/III*

*RTE-III has not been run in 2111 or 2117 Computer

Compatibility with other HP network products

The 91740A/B and 91741A DS/1000 software-firmware products are compatible with 32190A DS/3000 software in HP 3000 Series II/III systems and the 91780A RJE/1000 IBM 360/370 remote job entry package. The DS/1000 software is not compatible with 91700A, 91703A, 91704A, or 91705A Distributed systems communications packages. However, RTE-C and RTE-II/III programs using those packages are upward compatible with DS/1000 with only minor modifications.

Minimum system requirements

For DS/1000 nodes based on HP 1000 computer systems

	Node capability levels		
	Minimum RTE-M (RTE-MII)	Mapped RTE-M (RTE-MIII)	RTE-IVB
HP 1000 Product numbers			
—for desk-style system	2174B/5B	2174B/5B	2176D/7D
—for upright cabinet system	2174A/5A	2174A/5A	2176C/7C
128k bytes of memory		Option 014 and 12786A/88A‡	Included
For each hardwired conn.*	12771A	12771A	12771A
For priv. int. control (required w/modem comm., optional w/hardwired comm.)	12620A	12620A	12620A
For each modem conn.**	12773A	12773A	12773A
DS/1000 software-firmware	91740B +020	91740B +020	91740B +020

*The 12771A includes two interface cards, one for the computer at each end of the hardware connection; for cable lengths longer than 7.3m (24 ft), 91720A/91721A communication cables are available.

**Also requires user-furnished full-duplex modem.

‡Other memory packages are available for providing more than 128k bytes and/or fault control.

For DS/1000 nodes based on HP 1000 M-Series computers

	Node capability levels		
	Minimum RTE-M (RTE-MII)	Mapped RTE-M (RTE-MIII)	RTE-IVB
Computer with 9 I/O chan	2108M*		
Computer with 14 I/O chan		2112M*	2112M*
Memory protect	12892B		
Time base generator	12539C	12539C	12539C
Power fail recovery system			
—for 2108A/B	12944A/B	12944A/B	12944A/B
—for 2112A/B	12991A/B	12991A/B	12991A/B
RTE-M operating system	92064A‡	92064A‡	
RTE-IVB operating system			92068A‡
System console and standard input unit (can also use CRT or printing terminals without Mini cartridge I/O if 12925A Punched Tape Reader Subsystem is also provided)	2645A/48A w/007, & 030 plus 13260B or 13260B +003 12966A +001	2645A/48A w/007, & 030 plus 13260B or 13260B +003 12966A +001	2645A/48A w/007, & 030 plus 13260B or 13260B +003 12966A +001
For each hardwired conn.	21771A†	12771A†	12771A†
For priv. int. control (required w/modem comm., optional w/hardware comm.)	12620A	12620A	12620A
For each modem connection**	12773A**	12773A**	12773A**
DS/1000 software-firmware	91740A‡	91740A‡	91740A‡
Disc subsystem; one of:			
—4.9M byte cartridge disc			12960A
—14.7M byte cartridge disc			12962C/D
—19.6M byte cartridge disc			7906M/MR w/interface 7920M
—50M byte top-loading disc			w/interface 7925M
—120M byte top-loading disc			w/interface

*Or 2108A/B or 2112A/B equipped with memory comparable to the 2108M (64k bytes) or 2112M (128k bytes).

‡Must specify media option for operating systems and DS/1000 software-firmware.

†The 12771A includes two interface cards, one for the computer at each end of the hardware connection; for cable lengths longer than 7.3m (24 ft) 91720A/91721A communication cables are available.

**Also requires user-furnished full-duplex modem.

Requirement for use of existing 2108A/2112A computer with 12977A or 12976A-003 in DS/1000 node

The DS/1000 firmware in 91740A requires space used by the second FFP card of the 12977A or 12976A-003. For that reason, the 12977A or 12976A with option 003 must be replaced with the 12977B Fast Fortran Processor, which provides both dynamic mapping and fast Fortran instructions on a single board.

For DS/1000 nodes based on HP 1000 E-Series and F-Series computers

The requirements for DS/1000 nodes based on HP 1000 E-Series or F-Series computers are identical to those for DS/1000 nodes based on HP 1000 M-Series computers except as follows:

1. Computers are models 2109A/B/E, 2111F, 2113A/B/E, or 2117F instead of 2108A/B/M or 2112A/B/M.
2. 2109E and 2111F include 64k bytes of memory; 2113E and 2117F include 128k bytes of memory. 2109A/B, or 2113A/B must be comparably equipped.
3. 13304A Firmware accessory board (included in 2109E, 2111F, 2113E, and 2117F) is required.
4. DS/1000 software-firmware is 91740B instead of 91740A.

Additional HP 1000 computer system requirements for HP 1000-to-HP 3000 communication

1. 12889A Hardwired serial interface and appropriate length of 30220A cabling.
2. 91741A+020 DS/1000 software enhancement for HP 1000-to-HP 3000 communications.
3. 12897B Dual Channel Port Controller (DCPC).

Requirement for operation with RTE-IVB

DS/1000 network software-firmware must be revision code 1913 or later for operation with the 92068A RTE-IVB system.

Requirements for remote data base access

The remote data base to be accessed must be managed by the 92069A IMAGE/1000 Data Base Management System, operating under the 92068A RTE-IVB real-time executive system.

Responsibilities of the customer

The DS/1000 customer must assume the following responsibilities with the purchase of DS/1000 software-firmware:

1. Installation of communication facilities (cables and/or modems), their connection to the HP 1000 Computer Systems equipped with DS/1000, and the establishment of successful communications between two HP 1000 Computer Systems equipped with DS/1000 is the customer's responsibility.
2. One person in the customer's organization must be designated as the Network Manager. This person will assume responsibility for configuration and generation of the customer's systems and function as the focal point of HP's support of the network. This person must be knowledgeable in HP's RTE operating system and must have taken the DS/1000 User's and Theory of Operation courses.
3. DS/1000 software-firmware is a customer-installed product unless it is ordered with an HP 1000 System for which HP performs that service prior to system shipment.

4. Hewlett-Packard strongly recommends that the customer purchase the Software Subscription Service (or Comprehensive Software Support) for DS/1000 and Basic Monthly Maintenance for the DS/1000 firmware and communications interfaces.

Ordering information

91740A DS/1000 Network software-firmware (for HP 1000 M-Series computers)

The 91740A DS/1000 software-firmware includes:

1. Firmware kit, including DS/1000 firmware driver instructions board and communications bootstrap loader (CBL) ROM.
2. One of software media choice options 010 or 020, which must be ordered.
3. The following manuals.
 - a. 91740-90001 91740A/B Part number catalog.
 - b. 91740-90002 91740A/B Programmer's manual.
 - c. 91740-90003 91740A/B Network manager's manual.
 - d. 91740-90015 Guide for new users of DS/1000.
4. 91740-90007 91740A Firmware manual.

91740B DS/1000 Network software-firmware (for HP 1000 E/F-Series Computers or HP 1000 Systems)

The firmware includes:

1. Firmware kit, including three 4k ROMs for installation on the 13304A Firmware accessory board and a communications bootstrap loader (CBL) ROM.
- 2-3. Same as items 2 and 3 of 91740A, above.
4. 91740-90009 91740B Firmware manual.

91741A DS/1000 Software enhancement for HP 1000-to-HP 3000 communications

The 91741A software enhancement package includes:

1. One of software media options 010 or 020, which must be ordered.
2. 91741-90001 91741A Part number catalog.
3. 91740-90015. Guide for new users of DS/1000.

91740A/B and 91741A options

010: Provides software paper tape.

020: Provides software on Mini cartridges.

91740P Right to duplicate 91740A for use on an additional HP 1000 M-Series computer system

91740P consists of:

1. The right to make one copy of software purchased with the 91740A DS/1000 software-firmware.
2. All manuals furnished with 91740A software and firmware for use on 2108 or 2112 Computer, items 1, 3, and 4 of 91740A, above.

91740R Right to duplicate 91740B for use on an additional HP 1000 E-Series or F-Series computer system

91740R consists of:

1. The right to make one copy of software purchased with the 91740B DS/1000 software-firmware.
2. All manuals furnished with 91740B software and firmware for use on 2109, 2111, 2113, or 2117 Computer, items 1 and 4 of 91740B, above, and item 3 of 91740A, above.

91741R Right to duplicate 91741A DS/1000 Software enhancement for use on an additional computer system

91741R consists of:

1. The right to make one copy of the original software purchased with the 91741A DS/1000 Software enhancement.
2. 91741-90001 91741A Software part number catalog.

Software support products available

91740T Customer Support Service for 91740A/B software (same media option as 91740A/B)

91740V Central support for an additional copy of 91740A/B software

91740S Software Subscription Service for 91740A/B software (same media options as 91740A/B)

91740Q Manual Update Service for 91740A/B manuals

91741T Customer Support Service for 91741A software (same media option as 91741A)

91741V Central support for additional copy of 91741A software

91741S Software Subscription Service for 91741A software (same media option as 91741A)



HP 1000 M/E/F-Series Computer serial interface and cables

product numbers 12771A, 91720A, 91721A

The 12771A Computer serial interface is a two card interface with male and female cables that forms a complete direct connect hardware communications link between two HP 1000 computer systems equipped with 91740A/B DS/1000 network software-firmware and managed by HP's RTE-M, RTE-III, or RTE-IV/IVB operating system. The 12771A interface can also be used with 91750A DS/1000-IV network software if 91740A/B/P/R firmware is also provided in each node using the 12771A. For convenient interconnection between interface cards supplied with the 12771A over lengths greater than 7.3m (24 ft), Hewlett-Packard offers 91720A and 91721A communications cables in various lengths.

Features

- Data rates to 62,500 bytes/second at distances to 183m (600 ft)
- Transmission distances to 3.048km (10,000 ft) at rates to 3,220 bytes/second
- Simple, individually shielded dual twisted pair cable connection
- Optically isolated input breaks ground loops, maximizes noise immunity
- Complete two-card link between two computers

Functional specifications

Capacity

One complete, bit-serial duplex channel per interface, with two cards, one for each computer at either end of the communications channel.

Hardwire cable lengths and maximum hardware transmission speeds

Cable Lengths		Max. Transmission speeds bytes/second†
metres	feet	
7 - 180	24 - 600	62,500
181 - 360	601 - 1200	39,200
361 - 1200	1201 - 4000	22,400
1201 - 1600	4001 - 5400	12,100
1601 - 2200	5401 - 7300	6,300
2201 - 3000	7301 - 10000	3,220

†Transmission speeds are user-selected by jumper on each interface card to correspond with cable length used. These are maximum hardware speeds; network throughput rates will be lower because of software overhead.

Error control

Errors detected in hardware word parity check on the 12771A board and in the longitudinal or diagonal parity checks on the blocks received (which are computed in 91740A/B firmware) are corrected by retransmission.

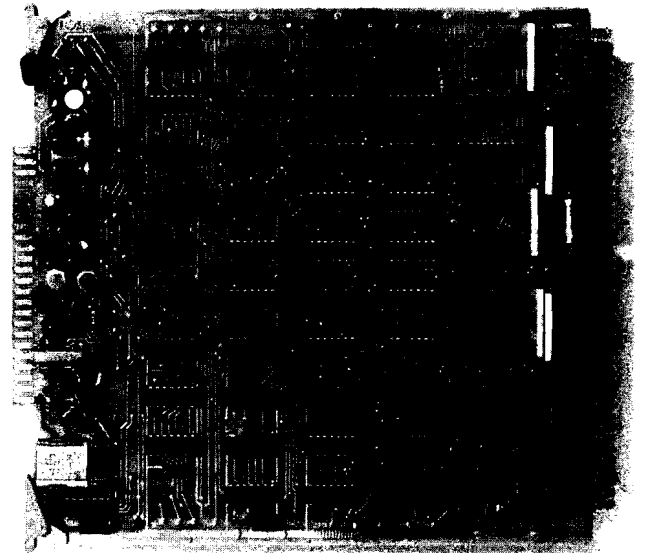

Configuration information

Computer and system compatibility: The 12771A interface is compatible with 2108, 2109, 2111, 2112, 2113, and 2117 computers and HP 1000 Model 20, 25, 41, and 46 Computer Systems.

Computer I/O channels required: One for each computer interconnection.

Limitations: The 12771A has optical isolation for intra-building communication. **It is not recommended or warranted for interbuilding communication.**

Software and firmware required: 91740A/B DS/1000 network software-firmware or 91750A DS/1000-IV software and 91740A/B/P/R DS/1000 firmware.

Additional equipment required for installation: For cable lengths greater than 7.3m (24 ft), HP communications cables, model 91720A (with unassembled connectors) or 91721A (with assembled connectors), or user fabricated cables will be required to complete interconnection of the two cards furnished in the 12771A interface (see diagram on next page).

Installation: Set jumper W1 to select correct data rate and jumper W2 to position A on both interface cards. Then plug the interface cards into the I/O backplanes of their respective computers, interconnect them with the two 3.65m (12 ft) cables furnished, plus communications cables as required, and integrate the interfaces and the 91740A/B DS/1000 network software and firmware into the computer operating system.

Current required from computer power supply
 1.6A(+5V), 0.07A(-2V), 0.09A(+12V), 0.095A(-12V).

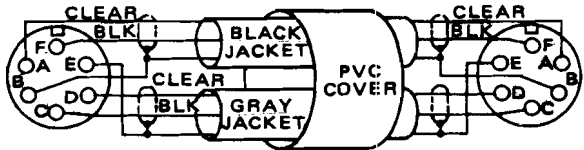
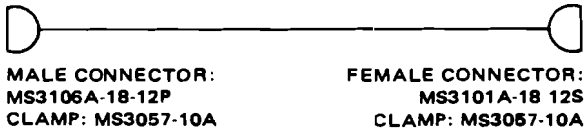

NOTE: Two lengths of Belden type 8762 Cabling, or equivalents of the required length is recommended for customers desiring to fabricate their own Communications cable.

HP 91721A Communications cable wiring diagram

Ordering Information

12771A Computer serial interface

The 12771A Computer serial interface includes:

1. Two 12665-60001 Hardwire serial data interface cards.
2. 12665-60002 3.65m (12 ft) Interface cable with male connector.
3. 12665-60003 3.65m (12 ft) Interface cable with female connector.
4. Two 12665-60004 Diagnostic hoods.
5. Two 12665-90001 Interface manuals.

91720A 76m (250 ft) Communications cable (with un-assembled connectors)

91721A 76m (250 ft) Communications cable (with assembled connectors)

91720A and 91721A options

- 001:** Adds 76m (250ft) to cable length for total of 152m (500 ft).
- 002:** Adds 221m (725 ft) to cable length for total of 297m (975 ft).



HEWLETT
PACKARD

HP 1000 M/E/F-Series Computer modem interface

product number 12773A

The 12773A Computer modem interface provides for interconnection of HP 1000 computer systems in the DS/1000 network using full-duplex modems as specified below. The 12773A interface is supported by the 91740A/B network software-firmware package, which operates in computer systems managed by HP's RTE-M, RTE-III, or RTE-IV/IVB operating system. The 12773A interface can also be used with 91750A DS/1000-IV network software if 91740A/B/P/R firmware is also provided in each node using the 12773A.

Features

- EIA RS-232-C compatibility
- Full duplex operation
- Compatibility with either synchronous or asynchronous modems
- Built-in error detection

Functional specifications

Interface compatibility

EIA RS-232-C and CCITT V.24 with full duplex operation.

Transmission mode

Bit-serial, synchronous or asynchronous adaptable to modem used.

Transmission link

Full duplex over switched (direct distance dial) or private (leased) common carrier telephone line. Modems may have automatic answering capability.

Data transfer rates

Asynchronous: Approximately 300, 600, or 1200 bits/sec.

Synchronous: Depends upon modem selected.

Error control

Errors detected in hardware word parity check on the 12773A board and in the longitudinal and diagonal parity checks on the blocks received (which are computed in 91740A/B firmware) are corrected by retransmission under firmware controls.

Configuration information

Computer and system compatibility: The 12773A interface is compatible with 2108, 2109, 2111, 2112, 2113, and 2117 computers and HP 1000 Model 20, 25, 41, and 46 Computer Systems.

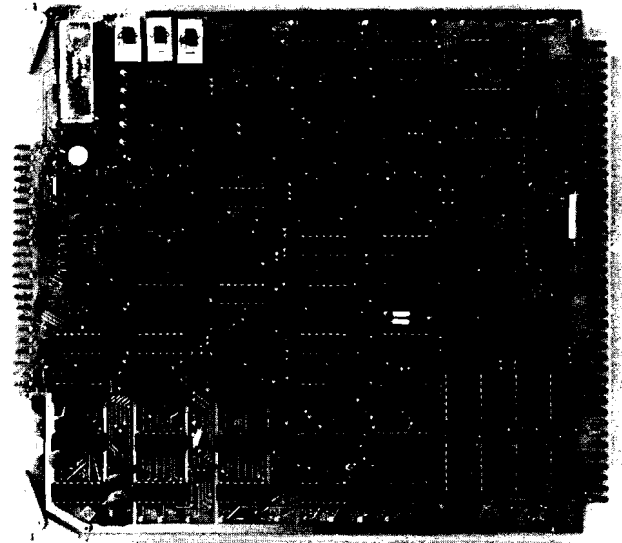

I/O channels required: One for 12620A interface used as privileged interrupt fence and one for each DS/1000 modem communications channel.

Software and firmware required: 91740A/B DS/1000 network software-firmware or 91750A DS/1000-IV software and 91740A/B/P/R DS/1000 firmware.

Additional equipment required for installation: 12620A interface used as privileged interrupt fence and user-furnished modem. Operation requires similarly-equipped system at other end of DS/1000 communications channel.

Installation: Set switches on the interface to select synchronous or asynchronous operation and (for asynchronous operation) set jumper to select appropriate data rate to match modems used at both ends of common carrier communications line. Then plug interface into the computer I/O backplane, connect interface cable to modem, and integrate the interface and DS/1000 software and firmware into the computer operating system.

Current required from computer power supply

1.6A(+5V), 0.07A(-2V), 0.04A(+12V), 0.04A(-12V).

Compatible modems and communication lines: See Table 1.

Table 1. Connections, Modems, and Data Rates

Connection via	Modem Type	Maximum Data Rate
Switched Telephone (Direct Distance Dialing) Network	Bell 103A2	To 300 bits/sec
	Bell 201C	To 2000 bits/sec
	Bell 202T	To 2400 bits/sec
	HP 37210T	To 4800 bits/sec
	Vadic VA3400	To 1200 bits/sec
Private lines	Bell 103A3	To 300 bits/sec
	Bell 201A3	To 2000 bits/sec
	Bell 201C	To 2400 bits/sec
	Bell 202T	To 2000 bits/sec
	Bell 208A	To 4800 bits/sec
	Bell 209A	To 9600 bits/sec
	HP 37210T	To 4800 bits/sec
	HP 37220T	To 9600 bits/sec
	HP 37230A	To 19200 bits/sec

Ordering information

12773A DS/1000 Modem interface

The DS/1000 Modem interface includes:

1. 12773-60001 Modem interface card.
2. 12773-60002 3.65m (12 ft) Interface cable.
3. 12773-60003 Diagnostic hood.
4. 12773-90001 Interface manual.



